

Generic Environmental Impact Statement for Continued Storage of Spent Nuclear Fuel

Final Report

AVAILABILITY OF REFERENCE MATERIALS IN NRC PUBLICATIONS

NRC Reference Material

As of November 1999, you may electronically access NUREG-series publications and other NRC records at NRC's Public Electronic Reading Room at <http://www.nrc.gov/reading-rm.html>. Publicly released records include, to name a few, NUREG-series publications; *Federal Register* notices; applicant, licensee, and vendor documents and correspondence; NRC correspondence and internal memoranda; bulletins and information notices; inspection and investigative reports; licensee event reports; and Commission papers and their attachments.

NRC publications in the NUREG series, NRC regulations, and Title 10, "Energy," in the *Code of Federal Regulations* may also be purchased from one of these two sources.

1. The Superintendent of Documents
U.S. Government Printing Office
Mail Stop SSOP
Washington, DC 20402-0001
Internet: bookstore.gpo.gov
Telephone: 202-512-1800
Fax: 202-512-2250
2. The National Technical Information Service
Springfield, VA 22161-0002
www.ntis.gov
1-800-553-6847 or, locally, 703-605-6000

A single copy of each NRC draft report for comment is available free, to the extent of supply, upon written request as follows:

Address: U.S. Nuclear Regulatory Commission
Office of Administration
Publications Branch
Washington, DC 20555-0001

E-mail: DISTRIBUTION.RESOURCE@NRC.GOV
Facsimile: 301-415-2289

Some publications in the NUREG series that are posted at NRC's Web site address <http://www.nrc.gov/reading-rm/doc-collections/nuregs> are updated periodically and may differ from the last printed version. Although references to material found on a Web site bear the date the material was accessed, the material available on the date cited may subsequently be removed from the site.

Non-NRC Reference Material

Documents available from public and special technical libraries include all open literature items, such as books, journal articles, transactions, *Federal Register* notices, Federal and State legislation, and congressional reports. Such documents as theses, dissertations, foreign reports and translations, and non-NRC conference proceedings may be purchased from their sponsoring organization.

Copies of industry codes and standards used in a substantive manner in the NRC regulatory process are maintained at—

The NRC Technical Library
Two White Flint North
11545 Rockville Pike
Rockville, MD 20852-2738

These standards are available in the library for reference use by the public. Codes and standards are usually copyrighted and may be purchased from the originating organization or, if they are American National Standards, from—

American National Standards Institute
11 West 42nd Street
New York, NY 10036-8002
www.ansi.org
212-642-4900

Legally binding regulatory requirements are stated only in laws; NRC regulations; licenses, including technical specifications; or orders, not in NUREG-series publications. The views expressed in contractor-prepared publications in this series are not necessarily those of the NRC.

The NUREG series comprises (1) technical and administrative reports and books prepared by the staff (NUREG-XXXX) or agency contractors (NUREG/CR-XXXX), (2) proceedings of conferences (NUREG/CP-XXXX), (3) reports resulting from international agreements (NUREG/IA-XXXX), (4) brochures (NUREG/BR-XXXX), and (5) compilations of legal decisions and orders of the Commission and Atomic and Safety Licensing Boards and of Directors' decisions under Section 2.206 of NRC's regulations (NUREG-0750).

DISCLAIMER: This report was prepared as an account of work sponsored by an agency of the U.S. Government. Neither the U.S. Government nor any agency thereof, nor any employee, makes any warranty, expressed or implied, or assumes any legal liability or responsibility for any third party's use, or the results of such use, of any information, apparatus, product, or process disclosed in this publication, or represents that its use by such third party would not infringe privately owned rights.

Generic Environmental Impact Statement for Continued Storage of Spent Nuclear Fuel

Final Report

Manuscript Completed: August 2014
Date Published: September 2014

**Waste Confidence Directorate
Office of Nuclear Material Safety and Safeguards
U.S. Nuclear Regulatory Commission
Washington, D.C. 20555-0001**

COVER SHEET

Responsible Agency: U.S. Nuclear Regulatory Commission, Office of Nuclear Material Safety and Safeguards

Title: NUREG-2157, Generic Environmental Impact Statement for Continued Storage of Spent Nuclear Fuel – Final Report, Volumes 1 and 2

For additional copies or questions about this Generic Environmental Impact Statement, contact:

Sarah Lopas
NEPA Communications Project Manager

Phone: 1-800-368-5642, extension 287-0675

Email: Sarah.Lopas@nrc.gov

U.S. Nuclear Regulatory Commission
Office of Nuclear Material Safety and Safeguards
Waste Confidence Directorate
Mail Stop 3WFN 14-C64
11555 Rockville Pike
Rockville, Maryland 20852

Abstract

This *Generic Environmental Impact Statement for Continued Storage of Spent Nuclear Fuel* (GEIS) generically determines the environmental impacts of continued storage, including those impacts identified in the remand by the Court of Appeals in the *New York v. NRC* decision, and provides a regulatory basis for a revision to 10 CFR 51.23 that addresses the environmental impacts of continued storage for use in future NRC environmental reviews. In this context, “the environmental impacts of continued storage” means those impacts that could occur as a result of the storage of spent nuclear fuel at at-reactor and away-from-reactor sites after a reactor’s licensed life for operation and until a permanent repository becomes available. The GEIS evaluates potential environmental impacts to a broad range of resources. Cumulative impacts are also analyzed.

Because the timing of repository availability is uncertain, the GEIS analyzes potential environmental impacts over three possible timeframes: a short-term timeframe, which includes 60 years of continued storage after the end of a reactor’s licensed life for operation; an additional 100-year timeframe (60 years plus 100 years) to address the potential for delay in repository availability; and a third, indefinite timeframe to address the possibility that a repository never becomes available. All potential impacts in each resource area are analyzed for each continued storage timeframe.

The GEIS contains several appendices that discuss specific topics of particular interest, including the technical feasibility of continued storage and repository availability as well as the two technical issues involved in the remand of *New York v. NRC*—spent fuel pool leaks and spent fuel pool fires. Finally the GEIS contains NRC’s responses to public comments on the draft GEIS and proposed Rule and in doing so provides additional technical background on, and explanation of, the GEIS’s analyses and conclusions.

The GEIS also discusses the NRC’s Federal action—the adoption of a revised Rule, 10 CFR 51.23, to codify (i.e., adopt into regulation) the analysis in the GEIS of the environmental impacts of continued storage of spent fuel—and the options the NRC could take under the no-action alternative.

Contents

Abstract	iii
Figures	xix
Tables	xxi
Executive Summary	xxiii
Abbreviations/Acronyms	lxvii
Units of Measure	lxxi
1.0 Introduction	1-1
1.1 History of Waste Confidence	1-1
1.2 Scope of the Generic Environmental Impact Statement	1-4
1.3 Purpose of the Generic Environmental Impact Statement	1-5
1.4 Proposed Federal Action	1-5
1.5 Purpose of and Need for the Proposed Action	1-6
1.6 Alternatives	1-6
1.6.1 No-Action Alternative	1-6
1.6.1.1 Site-Specific Review Option	1-7
1.6.1.2 GEIS-Only Option	1-8
1.6.1.3 Policy-Statement Option	1-8
1.6.2 Alternatives Considered but Eliminated	1-9
1.6.2.1 Cessation of Licensing or Cessation of Reactor Operation	1-9
1.6.2.2 Implementing Additional Regulatory Requirements	1-10
1.6.3 Comparison of Reasonable Alternatives	1-10
1.7 Public and Agency Involvement	1-11
1.7.1 Scoping Process	1-11
1.7.2 Public Comments Received on the Draft GEIS and Proposed Rule	1-12
1.7.3 Cooperating Agencies	1-12
1.8 Analytical Approach	1-12
1.8.1 Approach to Impact Assessment	1-12
1.8.2 Timeframes Evaluated	1-13
1.8.3 Analysis Assumptions	1-15
1.8.4 Other Environmental Analyses	1-18
1.8.5 Significance of Environmental Impacts	1-23

Contents

1.8.6	Issues Eliminated from Review in this GEIS	1-24
1.8.7	GEIS Contents.....	1-24
1.9	Other Applicable Federal Requirements	1-25
1.10	References	1-27
2.0	Generic Facility Descriptions and Activities	2-1
2.1	Generic Facility Descriptions.....	2-1
2.1.1	At-Reactor Continued Storage Site Descriptions	2-2
2.1.1.1	General Description of Single-Unit Nuclear Power Plant Site.....	2-2
2.1.1.2	General Description of Multiple-Unit Nuclear Power Plant Sites.....	2-5
2.1.1.3	Reactor and Fuel Technologies.....	2-6
2.1.2	Onsite Spent Fuel Storage and Handling.....	2-11
2.1.2.1	Spent Fuel Pools	2-11
2.1.2.2	At-Reactor Independent Spent Fuel Storage Installations.....	2-13
2.1.3	Away-from-Reactor ISFSIs.....	2-18
2.1.4	Dry Transfer System.....	2-20
2.2	Generic Activity Descriptions.....	2-24
2.2.1	Short-Term Storage Activities.....	2-24
2.2.1.1	Decommissioning Activities during Short-Term Storage.....	2-25
2.2.1.2	Activities in Spent Fuel Pools	2-27
2.2.1.3	Activities at At-Reactor ISFSIs.....	2-29
2.2.1.4	Activities at Away-from-Reactor ISFSIs	2-30
2.2.2	Long-Term Storage Activities	2-31
2.2.2.1	Construction and Operation of a DTS.....	2-31
2.2.2.2	Replacement of Storage and Handling Facilities	2-34
2.2.3	Indefinite Storage Activities	2-35
2.3	References	2-36
3.0	Affected Environment.....	3-1
3.1	Land Use	3-1
3.2	Socioeconomics	3-4
3.2.1	Employment and Income.....	3-5
3.2.2	Taxes.....	3-6
3.2.3	Demography	3-6
3.2.4	Housing	3-7
3.2.5	Public Services	3-7

3.2.6	Transportation	3-7
3.3	Environmental Justice	3-8
3.4	Climate and Air Quality	3-11
3.4.1	Climate	3-11
3.4.2	Greenhouse Gases	3-12
3.4.3	Criteria Pollutants	3-13
3.5	Geology and Soils	3-14
3.6	Surface-Water Quality and Use	3-16
3.7	Groundwater Quality and Use	3-17
3.8	Terrestrial Resources	3-19
3.8.1	Upland Vegetation and Habitats	3-20
3.8.2	Lowland and Wetland Vegetation and Habitats	3-21
3.8.3	Wildlife	3-21
3.9	Aquatic Ecology	3-22
3.9.1	Aquatic Habitats	3-23
3.9.1.1	Freshwater Systems	3-23
3.9.1.2	Estuarine Ecosystems	3-24
3.9.1.3	Marine Ecosystems	3-25
3.9.2	Aquatic Organisms	3-25
3.9.2.1	Fish	3-25
3.9.2.2	Aquatic Macroinvertebrates	3-26
3.9.2.3	Zooplankton	3-27
3.9.2.4	Single-Celled Algae	3-27
3.9.2.5	Other Aquatic Invertebrates and Vertebrates	3-27
3.9.2.6	Aquatic Macrophytes	3-27
3.10	Special Status Species and Habitats	3-28
3.11	Historic and Cultural Resources	3-30
3.12	Noise	3-33
3.13	Aesthetics	3-34
3.14	Waste Management	3-34
3.14.1	Low-Level Radioactive Waste	3-34
3.14.2	Mixed Waste	3-36
3.14.3	Hazardous Waste	3-36
3.14.4	Nonradioactive, Nonhazardous Waste	3-37
3.14.5	Pollution Prevention and Waste Minimization	3-37

Contents

3.15	Transportation	3-38
3.16	Public and Occupational Health	3-38
3.16.1	Radiological Exposure	3-39
3.16.1.1	Regulatory Requirements for Occupational Exposure	3-39
3.16.1.2	Regulatory Requirements for Public Exposure	3-40
3.16.2	Radiological Exposure from Naturally Occurring and Artificial Sources	3-40
3.16.3	Occupational Hazards	3-42
3.17	References	3-42
4.0	Environmental Impacts of At-Reacto r Continued Storage of Spent Fuel	4-1
4.1	Land Use	4-3
4.1.1	Short-Term Storage	4-4
4.1.2	Long-Term Storage	4-5
4.1.3	Indefinite Storage	4-6
4.2	Socioeconomics	4-6
4.2.1	Short-Term Storage	4-6
4.2.2	Long-Term Storage	4-7
4.2.3	Indefinite Storage	4-9
4.3	Environmental Justice	4-9
4.3.1	Short-Term Storage	4-11
4.3.2	Long-Term Storage	4-12
4.3.3	Indefinite Storage	4-14
4.4	Air Quality	4-14
4.4.1	Short-Term Storage	4-14
4.4.2	Long-Term Storage	4-16
4.4.3	Indefinite Storage	4-17
4.5	Climate Change	4-18
4.5.1	Short-Term Storage	4-18
4.5.2	Long-Term Storage	4-19
4.5.3	Indefinite Storage	4-20
4.6	Geology and Soils	4-20
4.6.1	Short-Term Storage	4-20
4.6.2	Long-Term Storage	4-21
4.6.3	Indefinite Storage	4-21

4.7	Surface-Water Quality and Use.....	4-22
4.7.1	Short-Term Storage.....	4-22
4.7.1.1	Spent Fuel Pools	4-22
4.7.1.2	ISFSIs	4-23
4.7.1.3	Conclusion	4-23
4.7.2	Long-Term Storage	4-23
4.7.3	Indefinite Storage	4-24
4.8	Groundwater Quality and Use	4-25
4.8.1	Short-Term Storage.....	4-25
4.8.1.1	Spent Fuel Pools	4-25
4.8.1.2	ISFSIs	4-27
4.8.1.3	Conclusion	4-27
4.8.2	Long-Term Storage	4-27
4.8.3	Indefinite Storage	4-28
4.9	Terrestrial Resources	4-29
4.9.1	Short-Term Storage.....	4-29
4.9.1.1	Spent Fuel Pools	4-29
4.9.1.2	ISFSIs	4-32
4.9.1.3	Conclusion	4-33
4.9.2	Long-Term Storage	4-33
4.9.3	Indefinite Storage	4-35
4.10	Aquatic Ecology.....	4-36
4.10.1	Short-Term Storage.....	4-36
4.10.1.1	Spent Fuel Pools	4-36
4.10.1.2	ISFSIs	4-42
4.10.1.3	Conclusion	4-43
4.10.2	Long-Term Storage	4-43
4.10.3	Indefinite Storage	4-44
4.11	Special Status Species and Habitat	4-44
4.11.1	Short-Term Storage.....	4-44
4.11.1.1	Spent Fuel Pools	4-44
4.11.1.2	ISFSIs	4-46
4.11.1.3	Conclusion	4-47
4.11.2	Long-Term Storage	4-48
4.11.3	Indefinite Storage	4-49
4.12	Historic and Cultural Resources	4-49

Contents

4.12.1 Short-Term Storage	4-50
4.12.2 Long-Term Storage	4-51
4.12.3 Indefinite Storage	4-54
4.13 Noise	4-55
4.13.1 Short-Term Storage	4-55
4.13.2 Long-Term Storage	4-56
4.13.3 Indefinite Storage	4-57
4.14 Aesthetics	4-57
4.14.1 Short-Term Storage	4-57
4.14.2 Long-Term Storage	4-58
4.14.3 Indefinite Storage	4-59
4.15 Waste Management	4-59
4.15.1 Short-Term Storage	4-59
4.15.1.1 Low-Level Radioactive Waste.....	4-59
4.15.1.2 Mixed Waste	4-60
4.15.1.3 Nonradioactive Waste.....	4-61
4.15.2 Long-Term Storage	4-61
4.15.2.1 Low-Level Radioactive Waste.....	4-62
4.15.2.2 Mixed Waste	4-63
4.15.2.3 Nonradioactive Waste.....	4-64
4.15.3 Indefinite Storage	4-65
4.15.3.1 Low-Level Radioactive Waste.....	4-65
4.15.3.2 Mixed Waste	4-65
4.15.3.3 Nonradioactive Waste.....	4-65
4.16 Transportation	4-66
4.16.1 Short-Term Storage	4-66
4.16.2 Long-Term Storage	4-67
4.16.3 Indefinite Storage	4-69
4.17 Public and Occupational Health	4-69
4.17.1 Short-Term Storage	4-69
4.17.2 Long-Term Storage	4-71
4.17.3 Indefinite Storage	4-71
4.18 Environmental Impacts of Postulated Accidents	4-72
4.18.1 Design Basis Events.....	4-74
4.18.1.1 Design Basis Events in Spent Fuel Pools.....	4-74

4.18.1.2	Design Basis Events in Dry Cask Storage Systems	4-81
4.18.1.3	Conclusion	4-84
4.18.2	Severe Accidents.....	4-84
4.18.2.1	Severe Accidents in Spent Fuel Pools.....	4-85
4.18.2.2	Severe Accidents in Dry Cask Storage Systems and DTSs	4-88
4.18.2.3	Conclusion	4-90
4.19	Potential Acts of Sabotage or Terrorism	4-91
4.19.1	Attacks on Spent Fuel Pools	4-92
4.19.2	Attacks on ISFSIs and DTS.....	4-94
4.19.3	Conclusion.....	4-97
4.20	Summary	4-97
4.21	References	4-99
5.0	Environmental Impacts of Away-From-Reactor Storage.....	5-1
5.1	Land Use	5-5
5.1.1	Short-Term Storage	5-5
5.1.2	Long-Term Storage	5-6
5.1.3	Indefinite Storage	5-8
5.2	Socioeconomics	5-8
5.2.1	Short-Term Storage.....	5-8
5.2.2	Long-Term Storage	5-9
5.2.3	Indefinite Storage	5-10
5.3	Environmental Justice	5-10
5.3.1	Short-Term Storage.....	5-11
5.3.2	Long-Term Storage	5-14
5.3.3	Indefinite Storage	5-15
5.4	Air Quality.....	5-15
5.4.1	Short-Term Storage.....	5-15
5.4.2	Long-Term Storage	5-18
5.4.3	Indefinite Storage	5-18
5.5	Climate Change.....	5-19
5.5.1	Short-Term Storage.....	5-19
5.5.2	Long-Term Storage	5-21
5.5.3	Indefinite Storage	5-21

Contents

5.6	Geology and Soils	5-21
5.6.1	Short-Term Storage	5-21
5.6.2	Long-Term Storage	5-22
5.6.3	Indefinite Storage	5-23
5.7	Surface-Water Quality and Use	5-23
5.7.1	Short-Term Storage	5-23
5.7.2	Long-Term Storage	5-24
5.7.3	Indefinite Storage	5-25
5.8	Groundwater Quality and Use	5-25
5.8.1	Short-Term Storage	5-25
5.8.2	Long-Term Storage	5-26
5.8.3	Indefinite Storage	5-26
5.9	Terrestrial Resources	5-27
5.9.1	Short-Term Storage	5-27
5.9.2	Long-Term Storage	5-28
5.9.3	Indefinite Storage	5-29
5.10	Aquatic Ecology	5-29
5.10.1	Short-Term Storage	5-29
5.10.2	Long-Term Storage	5-30
5.10.3	Indefinite Storage	5-31
5.11	Special Status Species and Habitats	5-31
5.11.1	Short-Term Storage	5-31
5.11.2	Long-Term Storage	5-33
5.11.3	Indefinite Storage	5-34
5.12	Historic and Cultural Resources	5-35
5.12.1	Short-Term Storage	5-35
5.12.2	Long-Term Storage	5-37
5.12.3	Indefinite Storage	5-40
5.13	Noise	5-41
5.13.1	Short-Term Storage	5-41
5.13.2	Long-Term Storage	5-42
5.13.3	Indefinite Storage	5-43

5.14 Aesthetics.....	5-43
5.14.1 Short-Term Storage.....	5-43
5.14.2 Long-Term Storage	5-44
5.14.3 Indefinite Storage	5-45
5.15 Waste Management	5-45
5.15.1 Short-Term Storage.....	5-45
5.15.2 Long-Term Storage	5-46
5.15.3 Indefinite Storage	5-48
5.16 Transportation	5-49
5.16.1 Short-Term Storage.....	5-49
5.16.2 Long-Term Storage	5-52
5.16.3 Indefinite Storage	5-54
5.17 Public and Occupational Health	5-54
5.17.1 Short-Term Storage.....	5-54
5.17.2 Long-Term Storage	5-55
5.17.3 Indefinite Storage	5-56
5.18 Environmental Impacts of Postulated Accidents	5-56
5.19 Potential Acts of Sabotage or Terrorism	5-58
5.20 Summary	5-58
5.21 References	5-60
6.0 Cumulative Impacts	6-1
6.1 Methodology for Assessing Cumulative Impacts.....	6-1
6.2 Spatial and Temporal Bounds of the Cumulative Impacts Assessment.....	6-3
6.3 Past, Present, and Reasonably Foreseeable Actions	6-3
6.3.1 General Trends and Activities	6-4
6.3.2 Other NRC-Regulated or Spent Fuel-Related Activities during Continued Storage.....	6-8
6.3.2.1 Final Reactor Shutdown Activities Prior to Decommissioning	6-8
6.3.2.2 Decommissioning of the Reactor Power Block (including the spent fuel pool), DTS, and ISFSI.....	6-9
6.3.2.3 Activities to Prepare the Spent Fuel for Transportation to a Repository for Final Disposal.....	6-9
6.3.2.4 Transportation of Spent Fuel from an At-Reactor or Away- From-Reactor Storage Facility to a Repository for Disposal.....	6-10

Contents

6.4	Resource-Specific Analyses.....	6-10
6.4.1	Land Use	6-10
6.4.1.1	Potential Cumulative Impacts from General Trends and Activities.....	6-10
6.4.1.2	Potential Cumulative Impacts from Other NRC-Regulated or Spent Fuel-Related Activities.....	6-11
6.4.1.3	Conclusion	6-12
6.4.2	Socioeconomics	6-12
6.4.2.1	Potential Cumulative Impacts from General Trends and Activities.....	6-13
6.4.2.2	Potential Cumulative Impacts from Other NRC-Regulated or Spent Fuel-Related Activities.....	6-13
6.4.2.3	Conclusion	6-15
6.4.3	Environmental Justice	6-15
6.4.3.1	Potential Cumulative Impacts from General Trends and Activities.....	6-16
6.4.3.2	Potential Cumulative Impacts from Other NRC-Regulated or Spent Fuel-Related Activities.....	6-17
6.4.3.3	Conclusion	6-18
6.4.4	Air Quality.....	6-18
6.4.4.1	Potential Cumulative Impacts from General Trends and Activities.....	6-19
6.4.4.2	Potential Cumulative Impacts from Other NRC-Regulated or Spent Fuel-Related Activities.....	6-19
6.4.4.3	Conclusion	6-20
6.4.5	Climate Change.....	6-21
6.4.5.1	Potential Cumulative Impacts from General Trends and Activities and from Other NRC-Regulated or Spent Fuel-Related Activities	6-21
6.4.5.2	Conclusion	6-23
6.4.6	Geology and Soils	6-23
6.4.6.1	Potential Cumulative Impacts from General Trends and Activities.....	6-23
6.4.6.2	Potential Cumulative Impacts from Other NRC-Regulated or Spent Fuel-Related Activities.....	6-24
6.4.6.3	Conclusion	6-25
6.4.7	Surface-Water Quality and Use.....	6-25
6.4.7.1	Potential Cumulative Impacts from General Trends and Activities.....	6-26

6.4.7.2	Potential Cumulative Impacts from Other NRC-Regulated or Spent Fuel-Related Activities.....	6-26
6.4.7.3	Conclusion	6-27
6.4.8	Groundwater Quality and Use	6-28
6.4.8.1	Potential Cumulative Impacts from General Trends and Activities.....	6-28
6.4.8.2	Potential Cumulative Impacts from Other NRC-Regulated or Spent Fuel-Related Activities.....	6-29
6.4.8.3	Conclusion	6-30
6.4.9	Terrestrial Resources	6-30
6.4.9.1	Potential Cumulative Impacts from General Trends and Activities.....	6-31
6.4.9.2	Potential Cumulative Impacts from Other NRC-Regulated or Spent Fuel-Related Activities.....	6-32
6.4.9.3	Conclusion	6-33
6.4.10	Aquatic Resources	6-34
6.4.10.1	Potential Cumulative Impacts from General Trends and Activities.....	6-34
6.4.10.2	Potential Cumulative Impacts from Other NRC-Regulated or Spent Fuel-Related Activities.....	6-35
6.4.10.3	Conclusion	6-36
6.4.11	Historic and Cultural Resources.....	6-37
6.4.11.1	Potential Cumulative Impacts from General Trends and Activities.....	6-38
6.4.11.2	Potential Cumulative Impacts from Other NRC-Regulated or Spent Fuel-Related Activities.....	6-38
6.4.11.3	Conclusion	6-39
6.4.12	Noise	6-40
6.4.12.1	Potential Cumulative Impacts from General Trends and Activities.....	6-41
6.4.12.2	Potential Cumulative Impacts from Other NRC-Regulated or Spent Fuel-Related Activities.....	6-41
6.4.12.3	Conclusion	6-42
6.4.13	Aesthetics	6-43
6.4.13.1	Potential Cumulative Impacts from General Trends and Activities.....	6-43
6.4.13.2	Potential Cumulative Impacts from Other NRC-Regulated or Spent Fuel-Related Activities.....	6-44
6.4.13.3	Conclusions	6-45

Contents

6.4.14	Waste Management	6-45
6.4.14.1	Potential Cumulative Impacts from General Trends and Activities.....	6-46
6.4.14.2	Potential Cumulative Impacts from Other NRC-Regulated or Spent Fuel-Related Activities.....	6-47
6.4.14.3	Conclusion	6-50
6.4.15	Transportation	6-50
6.4.15.1	Potential Cumulative Impacts from General Trends and Activities.....	6-51
6.4.15.2	Potential Cumulative Impacts from Other NRC-Regulated or Spent Fuel-Related Activities.....	6-51
6.4.15.3	Conclusion	6-53
6.4.16	Public and Occupational Health	6-53
6.4.16.1	Potential Cumulative Impacts from General Trends and Activities.....	6-54
6.4.16.2	Potential Cumulative Impacts from Other NRC-Regulated or Spent Fuel-Related Activities.....	6-55
6.4.16.3	Conclusion	6-55
6.4.17	Environmental Impacts of Postulated Accidents	6-55
6.4.17.1	Potential Cumulative Impacts from General Trends and Activities.....	6-56
6.4.17.2	Potential Cumulative Impacts from Other NRC-Regulated or Spent Fuel-Related Activities.....	6-57
6.4.17.3	Conclusion	6-57
6.5	Summary	6-58
6.6	References	6-59
7.0	Cost-Benefit Analysis	7-1
7.1	Assumptions.....	7-2
7.1.1	New Reactor Applications	7-4
7.1.2	Reactor License Renewal.....	7-6
7.1.3	ISFSI Licensing	7-7
7.2	Estimated Costs and Benefits of the Proposed Action.....	7-8
7.3	Estimated Costs and Benefits of the Site-Specific Review Option.....	7-9
7.4	Estimated Costs and Benefits of the GEIS-Only Option	7-10
7.5	Estimated Costs and Benefits of the Policy-Statement Option	7-12
7.6	Comparison of Alternatives	7-14
7.7	Final Analysis and Final Recommendation	7-17

7.8 References 7-17

8.0 Summary of Environmental Impacts of Continued Storage 8-1

8.1 Summarized Environmental Impacts of Continued Storage..... 8-2

8.2 Unavoidable Adverse Environmental Impacts of Continued Storage..... 8-4

8.3 Irreversible and Irretrievable Commitments of Resources Associated with Continued Storage 8-7

8.4 Relationship Between Short-Term Uses of the Environment for Continued Storage and the Maintenance and Enhancement of Long-Term Productivity..... 8-8

8.5 References 8-9

9.0 List of Preparers..... 9-1

10.0 Index..... 10-1

11.0 Glossary..... 11-1

Appendix A – Scoping Comments A-1

Appendix B – Technical Feasibility of Continued Storage and Repository Availability .. B-1

Appendix C – Outreach and Correspondence C-1

Appendix D – Draft GEIS and Proposed Rule Comment Summaries and Responses.... D-1

Appendix E – Analysis of Spent Fuel Pool Leaks..... E-1

Appendix F – Spent Fuel Pool Fires..... F-1

Appendix G – Spent Fuel Storage Facilities..... G-1

Appendix H – Estimated Costs of Alternatives H-1

Appendix I – High-Burnup Fuel I-1

Figures

ES-1	Three Storage Timeframes Addressed in this GEIS.....	xxx
1-1	Continued Storage Timeframes.....	1-14
1-2	NEPA Analyses for NRC Activities	1-19
2-1	Dry Storage of Spent Fuel	2-14
2-2	Licensed/Operating ISFSIs by State.....	2-16
2-3	Conceptual Sketches of a Dry Transfer System.....	2-22
2-4	Continued Storage Timeline	2-25
3-1	Map of NRC Regions Showing Locations of Operating Reactors	3-2

Tables

ES-1	Affected Resource Areas for At-Reactor Spent Fuel Storage	xxxiv
ES-2	Affected Resource Areas for Away-From-Reactor Spent Fuel Storage	xxxv
ES-3	Summary of Environmental Impacts of Continued At-Reactor Storage.....	xlvii
ES-4	Summary of Environmental Impacts of Away-From-Reactor Spent Fuel Storage.....	lix
ES-5	Summary of Cumulative Effects for Continued Storage of Spent Fuel.....	lx
1-1	List of NEPA Documents Used in Preparation of this GEIS	1-20
2-1	U.S. Pressurized Water Reactors with Shared Spent Fuel Pools	2-6
2-2	Stainless-Steel-Clad Fuel at Decommissioning Plants.....	2-7
3-1	Land Area Characteristics of Operating Nuclear Power Plants with Site-Specific ISFSI Licenses.....	3-4
3-2	Occupational Dose Limits for Adults Established by 10 CFR Part 20	3-40
3-3	Average Annual Effective Dose Equivalent of Ionizing Radiation to a Member of the U.S. Population for 2006.....	3-41
4-1	Reference Plant Withdrawal Rates and Heat Loads	4-30
4-2	Summary of Environmental Impacts of Continued At-Reactor Storage.....	4-98
5-1	Summary of Environmental Impacts of Continued Away-from-Reactor Storage.....	5-59
6-1	General Trends and Human Activities Occurring at or near Storage Facilities	6-5
6-2	Comparison of Annual Carbon Dioxide Emission Rates	6-22
6-3	Summary of Incremental Impacts from Continued Storage on Waste Management.....	6-46
6-4	Summary of the Cumulative Impacts from Continued Storage When Added to Other Federal and Non-Federal Activities	6-58
7-1	Estimated Costs of the Proposed Action	7-9
7-2	Constant and Discounted Estimated Costs of the Site-Specific Review Option.....	7-9
7-3	Constant and Discounted Estimated Costs of the GEIS-Only Option	7-11
7-4	Constant and Discounted Estimated Costs of the Policy-Statement Option	7-13
7-5	Summary of Constant and Discounted Estimated Costs for the Proposed Action and NRC's Potential Options in the Case of No Action (in millions of 2014 dollars)	7-15
7-6	Summary of Unquantified Costs and Benefits of the Proposed Action and NRC's Potential Options in Case of No Action.....	7-16
8-1	Summary of Environmental Impacts of Continued At-Reactor Storage.....	8-2
8-2	Summary of Environmental Impacts of Continued Storage at an Away-from- Reactor Independent Spent Fuel Storage Installation	8-3
8-3	Summary of the Cumulative Impacts from Continued Storage When Added to Other Federal and Non-Federal Activities	8-4
9-1	List of Preparers—NRC	9-2
9-2	List of Preparers—CNWRA	9-5
9-3	List of Preparers—PNNL	9-6

Executive Summary

This summary describes the contents of the U.S. Nuclear Regulatory Commission's (NRC's) Generic Environmental Impact Statement for Continued Storage of Spent Nuclear Fuel (GEIS). It briefly discusses the proposed action (a rulemaking), alternatives to the proposed action, and the NRC's recommendation to the Commission. It also describes the NRC's determinations regarding the environmental impacts of at-reactor and away-from-reactor continued storage of spent nuclear fuel (spent fuel) over short-term, long-term, and indefinite timeframes, including the NRC's analysis of spent fuel pool leaks and fires.

ES.1 What is Waste Confidence?

Historically, Waste Confidence has been the NRC's generic determination regarding the technical feasibility and environmental impacts of safely storing spent fuel beyond the licensed life for operations of a nuclear power plant. The Commission incorporated the generic determination in its regulations at Title 10 of the *Code of Federal Regulations* (CFR) 51.23, which satisfied the NRC's obligations under the National Environmental Policy Act of 1969, as amended (NEPA), with respect to the continued storage of spent fuel for commercial reactor licenses, license renewals, and spent fuel storage facility licenses and license renewals.

Continued Storage applies to the storage of spent fuel *after* the end of the licensed life for operations of a nuclear reactor and *before* final disposal in a permanent repository.

ES.2 Why Did the NRC Change the Name of the Generic Environmental Impact Statement and Rule?

During the public comment period on the draft GEIS and proposed Rule, the NRC asked four specific questions, one of which was, "Should the title of the rule be changed in light of a GEIS being issued instead of a separate Waste Confidence Decision?" The NRC received an overwhelming number of comments in favor of changing the name of the Rule; therefore, the title of the *Federal Register* Notice for the rulemaking has been changed to "Continued Storage of Spent Nuclear Fuel." Further, the title of the GEIS has been changed to, "Generic Environmental Impact Statement for Continued Storage of Spent Nuclear Fuel" to be consistent with the title of the rulemaking. Appendix D contains summaries of the public input received on the four specific questions on the proposed Rule and other comments received on the draft GEIS and proposed Rule as well as the NRC's responses to those comments.

ES.3 Why Has the NRC Developed a Generic Environmental Impact Statement?

Since the Waste Confidence Rule was originally developed in 1984, the NRC has periodically updated the Rule, with the last update completed in 2010. A number of parties challenged the 2010 Waste Confidence Rule in court, and in June 2012, the Court of Appeals for the District of Columbia Circuit ruled that the 2010 Waste Confidence rulemaking did not satisfy the NRC's NEPA obligations. The Court of Appeals identified deficiencies in the 2010 Waste Confidence rule related to the NRC's environmental analysis of spent fuel pool fires and leaks, and the environmental impacts should a repository not become available.

In response to the Court of Appeals' ruling, the Commission decided that the NRC would not issue any final licenses that relied upon the Waste Confidence Rule until the NRC addressed the deficiencies identified by the Court of Appeals (Commission Order CLI-12-16). The Commission separately directed the staff to develop an updated Waste

Confidence decision and Rule supported by an environmental impact statement (SRM-COMSECY-12-0016). The staff has prepared this GEIS to satisfy its NEPA obligations regarding the environmental impacts of continued storage of spent fuel in an efficient manner. The GEIS provides a regulatory basis for the revision of the Rule. Chapter 1 of the GEIS provides a more detailed discussion of the history of the Waste Confidence rulemaking.

To comply with **The National Environmental Policy Act of 1969 (NEPA)** Federal agencies:

- assess the environmental impacts of major Federal actions,
- consider the environmental impacts in making decisions, and
- disclose the environmental impacts to the public.

ES.4 What is the Proposed Action Being Addressed in this GEIS?

The proposed Federal action is the adoption of a revised rule—10 CFR 51.23—that codifies the analysis in the GEIS of the environmental impacts of continued storage of spent fuel.

Why is the NRC evaluating continued storage on a generic basis?

The NRC considers the continued storage of spent fuel an activity that is similar for all commercial nuclear power plants and storage facilities. Therefore, a generic analysis is an appropriate, effective, and efficient method of evaluating the environmental impacts of continued storage. Other examples of NRC generic environmental evaluations include the License Renewal GEIS (NUREG-1437), the Decommissioning GEIS (NUREG-0586), and the In-Situ Leach Uranium Milling Facilities GEIS (NUREG-1910).

ES.5 What is the Purpose and Need for the Proposed Action?

The need for the proposed action is to provide processes for use in NRC licensing to address the environmental impacts of continued storage. Historically, the NRC and license applicants have relied on 10 CFR 51.23 to conclusively address the environmental impacts of continued storage in environmental reports, environmental impact statements (EISs), environmental assessments (EAs), and hearings. The purpose of the proposed action is to preserve the efficiency of the NRC's licensing processes with respect to the environmental impacts of continued storage.

ES.6 Could the NRC Pursue Options Other Than This Rulemaking?

Yes. As discussed in Section 1.6 of the GEIS, the NRC considered several different approaches for evaluating the environmental impacts of continued storage. The NRC looked at the three options that it could have pursued if it chose not to adopt a revised 10 CFR 51.23.

1. *The Site-Specific Review Option.* The NRC would take no action to generically address the environmental impacts of continued storage and, instead, would address the environmental impacts of continued storage in individual, site-specific licensing reviews.
2. *The GEIS-Only Option.* The NRC would rely on the GEIS to analyze the environmental impacts of continued storage, which would then support site-specific licensing reviews. There would be no Rule, so site-specific EISs or EAs would incorporate the GEIS by reference or adopt the conclusions in the GEIS.
3. *The Policy-Statement Option.* The Commission would issue a policy statement that expresses the Commission's intent to either adopt or incorporate the environmental impacts in the GEIS into site-specific NEPA actions or to prepare a site-specific evaluation for each NRC licensing action.

The NRC determined that the environmental impacts of these three options, in the case of no action, are essentially the same because they are merely different administrative approaches to addressing the environmental impacts of continued storage. Further, in both the proposed action and all of the NRC's options in the case of no action, the NRC would analyze the environmental impacts of continued storage. The NRC's conclusion is to adopt a revised 10 CFR 51.23 because of the efficiencies that would be gained in reactor and spent fuel storage facility licensing reviews. Adopting a revised Rule minimizes expenditures on site-specific reviews, limits the potential for lengthy project delays, and has the same environmental impacts as the NRC's options in case of no action.

Executive Summary

During the scoping period and draft GEIS and proposed Rule comment period, the NRC received many suggested alternatives to the rulemaking, including calls for halting NRC licensing activities and shutting down operating reactors or imposing new requirements on nuclear power plants, such as storing spent fuel in special hardened onsite storage, reducing spent fuel pool density, and accelerating the transfer of spent fuel from pools to dry casks. The NRC determined that halting NRC licensing and closing nuclear reactors would not meet the purpose and need of the proposed action. The NRC also determined that additional

requirements on spent fuel storage would not meet the purpose and need. Further, the GEIS is a NEPA review and does not authorize the initial or continued operation of any nuclear power plant, nor does it authorize storage of spent fuel; therefore, this GEIS would not be the appropriate activity in which to mandate new spent fuel storage requirements.

This rulemaking does not authorize the initial or continued operation of any nuclear power plant, nor does it authorize storage of spent fuel. It does not permit a nuclear power plant or any other facility to operate or store spent fuel. Every nuclear power plant or specifically licensed spent fuel storage facility must undergo an environmental review as part of its site-specific licensing process.

ES.7 What is Covered in the GEIS?

The GEIS analyzes the environmental impacts of continued storage of spent fuel. The NRC has looked at the direct, indirect, and cumulative effects of continued storage for three timeframes—short-term, long-term, and indefinite. These timeframes are defined below and are discussed in more detail in Section 1.8.2 of the GEIS. The analyses contained in this GEIS provide a regulatory basis for the proposed revisions to 10 CFR 51.23. Appendix B addresses the technical feasibility of repository availability and continued safe storage of spent fuel while Appendices E and F address the consequences of spent fuel pool leaks and fires, respectively.

ES.8 What is Not Covered in the GEIS?

The NRC is evaluating the continued storage of commercial spent fuel in this GEIS. Thus, certain topics are not addressed because they are not within the scope of this review. These topics include:

- noncommercial spent fuel (e.g., defense waste),
- commercial high-level waste generated from reprocessing,
- greater-than-class-C waste,
- foreign spent fuel stored in the United States,
- nonpower reactor spent fuel (e.g., test and research reactors, including foreign generated fuel stored in the United States),

- need for nuclear power, and
- reprocessing of commercial spent fuel.

ES.9 Did the NRC Involve the Public or Governmental Organizations?

The NRC announced that it was planning to develop an EIS and requested comments on the proposed scope of the GEIS in a *Federal Register* Notice that was published on October 25, 2012 (77 FR 65137). Publication of this notice began a 70-day public comment period for scoping. The NRC also issued press releases, sent scoping letters to Tribal governments and State liaisons, and sent e-mails to approximately 1,050 stakeholders who had previously expressed interest in matters related to high-level waste. The NRC conducted four public scoping meetings that were all accessible via Internet and telephone, so people from all over the country could participate and give their comments on the scope of the Waste Confidence GEIS. In November 2012, the NRC met with representatives of the U.S. Environmental Protection Agency (EPA) to discuss the Waste Confidence rulemaking. The NRC also held a government-to-government meeting with the Prairie Island Indian Community in June 2013. There are no formal cooperating agencies identified in this environmental review.

At the end of the 70-day scoping period, the NRC summarized what it heard and responded to public comments in its *Scoping Summary Report*, which can be accessed at <http://pbadupws.nrc.gov/docs/ML1306/ML13060A128.pdf>.

A separate document at <http://pbadupws.nrc.gov/docs/ML1306/ML13060A130.pdf> lists the scoping comments the NRC received, organized by category.

At the end of the draft GEIS and proposed Rule comment period, the NRC summarized the public comments and provided responses in Appendix D of this final GEIS.

A separate document at <http://pbadupws.nrc.gov/docs/ML1415/ML14154A175.pdf> lists the comments the NRC received on the draft GEIS and proposed Rule.

On September 13, 2013, the EPA published a notice of availability in the *Federal Register* (78 FR 56695), starting the 75-day comment period on the draft GEIS. In response to the October 2013 government shutdown, which caused the agency to reschedule several public meetings, the NRC extended the comment period to December 20, 2013 (78 FR 66858). The NRC also issued press releases, sent letters to Tribal governments and State liaison officers, produced a YouTube video, held multiple teleconferences, and sent e-mails to approximately 3,000 stakeholders who had expressed interest in this project. During the comment period the NRC held 13 public meetings throughout the United States. There were approximately 1,400 total participants at those meetings. Overall, the NRC received approximately

Executive Summary

33,100 pieces of correspondence (e.g., e-mails, letters, postcards, etc.) from the public and recorded over 1,600 pages of transcripts.

GEIS Section 1.7 and Appendices A, C, and D discuss public and agency involvement in this environmental review and rulemaking. The Scoping Summary report provides information about the NRC's scoping activities and what the NRC heard during the scoping process. Appendix D provides the NRC's responses to comments received on the draft GEIS and proposed Rule as well as Agencywide Documents Access and Management System (ADAMS) accession numbers for public meeting summaries and transcripts.

The ADAMS electronic public reading room is available at <http://www.nrc.gov/reading-rm/adams.html>. If you encounter issues accessing ADAMS, call the NRC at 1-800-397-4209 or 301-415-4737, or send an e-mail to pdr.resource@nrc.gov.

ES.10 What Type of Comments Did the NRC Receive on the Draft GEIS?

The NRC transcribed approximately 1,600 pages of comments from nearly 500 meeting participants during the 13 public meetings and received approximately 33,100 written submittals during the comment period. The most common topics were general opposition to nuclear power, feasibility of safe storage and disposal, and alternatives. Other high-interest topics included spent fuel pool fires and leaks, institutional controls, high-burnup fuel, accidents, terrorism and security, expedited transfer of spent fuel to dry cask storage and hardened onsite storage of fuel, and general opposition to the Rule and GEIS. Detailed information on all correspondence, including authors and ADAMS accession numbers for submissions, is contained in a separate document titled, *Comments on the Waste Confidence Draft Generic Environmental Impact Statement and Proposed Rule*, which is located in ADAMS under Accession No. ML14154A175. Appendix D provides comment summaries and the NRC's responses to comments.

ES.11 What Were the Changes to the Final GEIS?

As stated earlier, the NRC received thousands of comments on the draft GEIS and proposed Rule. The NRC made changes to the final GEIS and proposed Rule to address some of the concerns raised in those comments. The NRC also added a glossary (Chapter 11). Some of the changes to the final GEIS are listed below.

High-Burnup Fuel. Because of interest from the public, the NRC added a new appendix (Appendix I) that provides background information on the licensing, storage, and transportation of high-burnup fuel.

Institutional Controls. Because of the volume of public comment on institutional controls, the NRC added additional information in Appendix B.

Purpose of GEIS, Proposed Federal Action, Purpose and Need, and Alternatives. In response to public comments regarding the structure of the GEIS and the rulemaking, the NRC has revised several sections of Chapter 1. The purpose of the GEIS (see Section 1.3) has been simplified to more clearly focus on determining the environmental impacts of continued storage and determining whether those impacts can be generically addressed. The proposed Federal action (in Section 1.4) is the adoption of a revised Rule that codifies, or adopts into regulation, the environmental impacts of continued storage. The purpose of the rulemaking (in Section 1.5) is to preserve the efficiency of NRC's licensing processes with respect to the environmental impacts of continued storage, and the need (also in Section 1.5) is to provide processes for use in NRC licensing to address the environmental impacts of continued storage. Because only the proposed action preserves the efficiency of the NRC's licensing processes with respect to the environmental impacts of continued storage, the NRC's alternatives analysis (in Section 1.6) focuses on the processes—or options—that the NRC could use in the case of no action. These options include all of the approaches to considering the impacts of continued storage that the NRC considered as alternatives in the draft GEIS. Finally, the NRC has clarified that the NRC's proposed action and its options in the case of no action are all different administrative approaches to addressing the environmental impacts of continued storage, and as such, their environmental impacts are not significant.

Cost-Benefit Analysis. The NRC updated its cost-benefit analysis so that it contains current—and reduced—costs for NRC staffing, as well as discounting that starts from a 2014 baseline instead of a 2013 baseline. All cost-benefit information is now presented in 2014 dollars. In addition, the cost-benefit analysis identifies costs associated with GEIS-development and rulemaking as past (or sunk) costs, but it retains them in the analysis to provide a complete picture of the costs associated with each activity. In addition, the NRC changed the arrangement of sections in Chapter 7 to reflect the revised approach to alternatives. Section 7.2 now contains the proposed action, while subsequent sections (Sections 7.3, 7.4, and 7.5) each contain NRC's options in the case of no action.

Cost of Continued Storage. Due to the large number of comments received on this topic the NRC added cost information for continued storage activities and facilities in Chapter 2.

Technical Feasibility of Safe Storage. Additional information was provided in Appendix B on the role of a regulatory framework and institutional controls during continued storage.

Substantive changes to the final GEIS are indicated by “change bars” in the margins of pages.

ES.12 How did the NRC Evaluate the Continued Storage of Spent Fuel in this GEIS?

The NRC looked at potential environmental impacts of continued storage in three timeframes: short-term storage, long-term storage, and indefinite storage (see Figure ES-1). The short-term and long-term storage timeframes include an assumption that a permanent geologic repository becomes available by the end of those timeframes. The indefinite storage timeframe assumes that a repository never becomes available. For a detailed discussion of the three timeframes, see Section 1.8.2.

The NRC has analyzed three timeframes that represent various scenarios for the length of continued storage that may be needed before spent fuel is sent to a repository. The first, most likely, timeframe is the short-term timeframe, which analyzes 60 years of continued storage after the end of a reactor's licensed life for operation. The NRC acknowledges, however, that the short-term timeframe, although the most likely, is not certain. Accordingly, the GEIS also analyzed two additional timeframes. The long-term timeframe considers the environmental impacts of continued storage for an additional 100 years after the short-term timeframe for a total of 160 years after the end of a reactor's licensed life for operation. Finally, although the NRC considers it highly unlikely, the GEIS includes an analysis of an indefinite timeframe, which assumes that a repository does not become available.

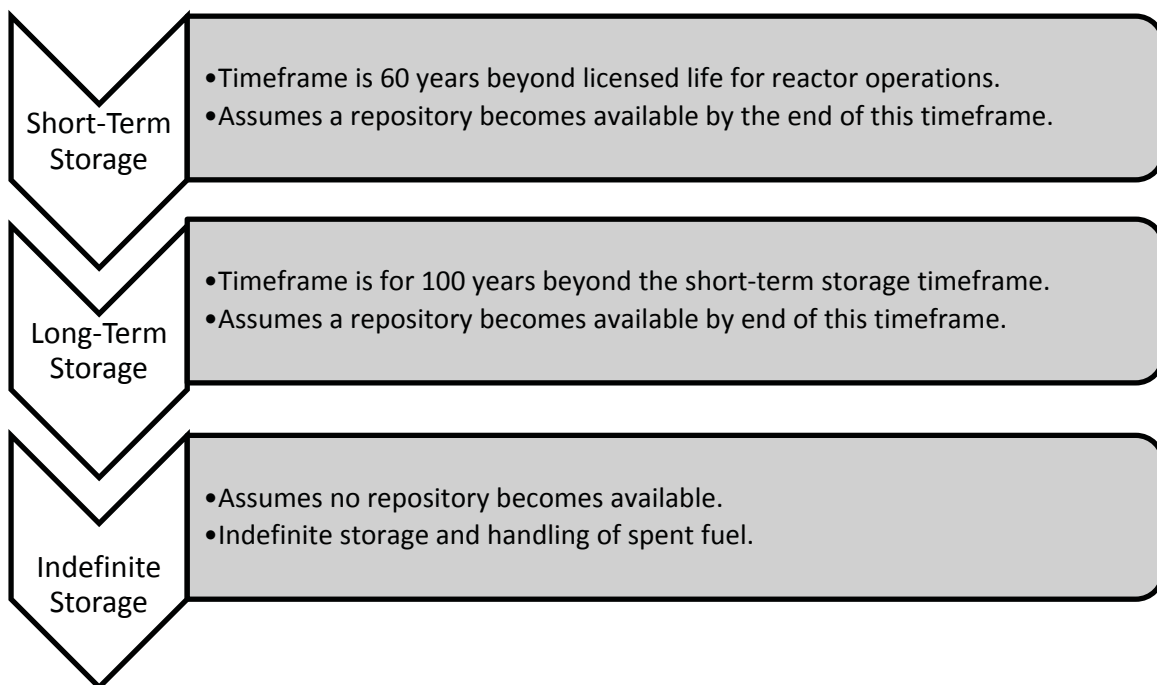

Figure ES-1. Three Storage Timeframes Addressed in this GEIS

To guide its analysis, the NRC also relied on certain assumptions regarding the storage of spent fuel. A detailed discussion of these assumptions is contained in Section 1.8.3. Some of these assumptions are listed below:

- Institutional controls would remain in place.
- Spent fuel canisters and casks would be replaced approximately once every 100 years.
- Independent spent fuel storage installation (ISFSI) and dry transfer system (DTS) facilities would also be replaced approximately once every 100 years.
- A DTS would be built at each ISFSI location for fuel repackaging.
- All spent fuel would be moved from spent fuel pools to dry storage by the end of the short-term storage timeframe (60 years).
- In accordance with NEPA, the analyses in the GEIS are based on current technology and regulations.

An **ISFSI** is a facility designed and constructed for the interim storage of spent fuel. Typically, spent fuel is stored in dry cask storage systems. NRC requirements state that dry cask storage must shield people and the environment from radiation and keep the spent fuel inside dry and nonreactive.

DTSs would be built at ISFSI sites (at-reactor or away-from-reactor) in the long-term storage timeframe. A DTS would enable retrieval of spent fuel for inspection or repackaging without the need to return the spent fuel to a spent fuel pool.

The NRC used previous environmental evaluations and technical reports to help inform the impact determinations in this GEIS. Chapter 1 includes a list of NEPA documents used in the development of the GEIS, and the end of each chapter includes a complete list of references. References are publicly available, and most are available in ADAMS.

ES.13 What Facilities and Activities are Addressed in the GEIS?

Chapter 2 describes typical facility characteristics and activities that the NRC used to assess the environmental impacts of continued storage of spent fuel. The GEIS looked at spent fuel storage at single- and multiple-reactor nuclear power plant sites, in spent fuel pools, at-reactor ISFSIs, and away-from-reactor ISFSIs. In addition to existing reactor designs and conventional spent fuel, the NRC also considered reactor and fuel technologies such as mixed oxide fuel (MOX) and small modular reactors.

Section 2.2 describes the activities related to the storage of spent fuel that are expected to occur during the three storage timeframes (short-term, long-term, and indefinite).

Executive Summary

- The *short-term storage* timeframe (60 years beyond the licensed life for operation of the reactor) includes routine maintenance and monitoring of the spent fuel pool and ISFSI and transferring spent fuel from pools to dry cask storage. Because decommissioning is required to be completed within 60 years after a reactor shuts down (unless additional time is necessary to protect public health and safety), the NRC assumes that all spent fuel will be moved from spent fuel pools to dry cask storage by the end of the short-term storage timeframe. For an away-from-reactor ISFSI, this timeframe includes construction and operation, including routine maintenance and monitoring, at the facility.
- The *long-term storage* timeframe (100 years beyond the initial 60-year [short-term] storage timeframe) includes activities such as continued facility maintenance, construction and operation of a DTS, and replacement of ISFSI and DTS facilities, including casks.
- The *indefinite storage* timeframe (no repository becomes available) assumes that the activities associated with long-term storage continue indefinitely, with ISFSI and DTS facilities being replaced at least once every 100 years.

MOX fuel is a type of nuclear reactor fuel that contains plutonium oxide mixed with either natural or depleted uranium oxide, in ceramic pellet form. This fuel differs from conventional nuclear fuel, which is made of pure uranium oxide.

Small modular reactors are nuclear power plants smaller in size (e.g., 300 MW(e)) than current generation baseload plants (e.g., 1,000 MW(e) or higher). These compactly designed reactors are factory-fabricated and can be transported by truck or rail to a nuclear power plant site.

The NRC also looked at ongoing regulatory activities that could affect the continued storage of spent fuel, including regulatory changes resulting from lessons learned from the September 11, 2001 terrorist attacks and the March 11, 2011 earthquake and tsunami that damaged the Fukushima Dai-ichi plant in Japan. Appendix B discusses a number of ongoing regulatory program reviews that ensure the safety and security of spent fuel storage and transportation.

ES.14 How did the NRC Describe Environmental Impacts?

NRC used terms from other NEPA documents, such as those for license renewal or new reactors, to define the standard of significance for assessing environmental issues.

SMALL—Environmental effects are not detectable or are so minor that they will neither destabilize nor noticeably alter any important attribute of the resource.

MODERATE—Environmental effects are sufficient to alter noticeably, but not to destabilize, important attributes of the resource.

LARGE—Environmental effects are clearly noticeable and are sufficient to destabilize important attributes of the resource.

For *risk-based determinations* (such as in the NRC’s analyses of severe accidents such as spent fuel pool fires), the probability of occurrence as well as the potential consequences have been factored into the determination of significance.

ES.15 What Environmental Resource Areas did the NRC Consider?

Chapter 3 discusses the environment that exists at and around the facilities where spent fuel is stored in spent fuel pools and at-reactor ISFSIs. This description of resources provides information that is incorporated into the analyses of environmental impacts of continued storage in Chapter 4 (at-reactor impacts) and Chapter 6 (cumulative impacts). The License Renewal GEIS (NUREG–1437) was the primary source of information in Chapter 3. The NRC also referenced information from site-specific environmental reviews, such as those for initial and renewal ISFSI licenses, the renewal of operating licenses, and combined licenses for new reactors. The affected resource areas and attributes discussed in the GEIS are listed in Table ES-1.

The affected environment and potential impacts of continued storage at an away-from-reactor ISFSI are discussed in Chapter 5 (away-from-reactor impacts). The analysis of away-from-reactor spent fuel storage in Chapter 5 is based, in general, on the description of the affected environment provided in Chapter 3. However, some aspects of those discussions would not be applicable, or would not be applicable in the same way, for an away-from-reactor ISFSI. This generic analysis is based, in part, on the siting evaluation factors in 10 CFR Part 72, Subpart E, which the location selected for the away-from-reactor ISFSI must meet. Further, for the analysis of continued storage at an away-from-reactor ISFSI, the term ISFSI refers to all of the original facilities that would be built (i.e., storage pads, casks, and canister transfer building).

The affected resource areas and attributes discussed in Chapter 5 of the GEIS are listed in Table ES-2.

Executive Summary

Table ES-1. Affected Resource Areas for At-Reactor Spent Fuel Storage

Affected Resource Area	Attributes
Land Use	Site areas and land requirements for operating nuclear power plants; land requirements for at-reactor ISFSIs; general land characteristics and coverage; land use in the vicinity of nuclear power plants; locations of nuclear power plants
Socioeconomics	Regional social, economic, and demographic conditions around nuclear power plant sites, including employment, taxes, public services, housing demand, and traffic
Environmental Justice	Human health and environmental effects; minority and low-income populations; subsistence consumption of fish and wildlife
Climate and Air Quality	Local and regional climate and air quality, including criteria pollutants and greenhouse gases
Geology and Soils	The physical setting of nuclear power plants and associated geologic strata and soils; different physiographic provinces in the United States
Water Resources	Surface-water and groundwater use and quality; existing radioactive leaks at nuclear power plants and tritium contamination of groundwater
Ecological Resources	Terrestrial and aquatic resources, including varied habitat such as wetlands and floodplains, wildlife, aquatic organisms, and threatened, endangered, and protected species and habitat
Historic and Cultural Resources	Historic and cultural resources that could be present at nuclear power plant sites
Noise	Ambient noise levels around existing spent fuel storage sites
Aesthetics	The existing scenic quality of spent fuel storage sites, including viewsheds with water bodies, topographic features, other visual landscape characteristics
Waste Management	Wastes generated by continued storage of spent fuel, including low-level radioactive waste, hazardous waste, mixed waste, nonradioactive/nonhazardous waste; pollution prevention and waste minimization; capacity of disposal facilities
Transportation	Transportation characteristics of reactor sites; workers involved in transportation activities; local, regional, and national transportation networks; populations that use them
Public and Occupational Health	NRC requirements for radiological protection of the public and workers from the continued storage of spent fuel; public radiation doses from natural and artificial sources; regulatory framework for occupational hazards

Table ES-2. Affected Resource Areas for Away-From-Reactor Spent Fuel Storage

Affected Resource Area	Attributes
Land Use	Site areas and land requirements for an away-from-reactor ISFSI to store 40,000 MTU; general land characteristics and coverage
Socioeconomics	Regional social, economic, and demographic conditions, including employment, taxes, public services, housing demand, and traffic
Environmental Justice	Human health and environmental effects; minority and low-income populations; subsistence consumption of fish and wildlife
Climate and Air Quality	Local and regional climate and air quality, including criteria pollutants and greenhouse gases
Geology and Soils	The physical setting and associated geologic strata and soils; the different physiographic provinces in the United States
Water Resources	Surface-water and groundwater use and quality
Ecological Resources	Terrestrial and aquatic resources, including varied habitat such as wetlands and floodplains, wildlife, aquatic organisms, and threatened, endangered, and protected species and habitat
Historic and Cultural Resources	Historic and cultural resources that could be present at an away-from-reactor ISFSI site
Noise	Ambient noise levels around general construction sites
Aesthetics	The existing scenic quality, including viewsheds with water bodies, topographic features, or other visual landscape characteristics
Waste Management	Wastes generated by continued storage of spent fuel, including low-level radioactive waste, hazardous waste, mixed waste, nonradioactive/nonhazardous waste; pollution prevention and waste minimization; capacity of disposal facilities
Transportation	Transportation characteristics; workers involved in transportation activities; local, regional, and national transportation networks and populations that use them
Public and Occupational Health	NRC requirements for radiological protection of the public and workers from the continued storage of spent fuel; public radiation doses from natural and artificial sources; the regulatory framework for occupational hazards

ES.16 What are the Environmental Impacts of Continued Storage?

Chapter 4 addresses potential environmental impacts of at-reactor continued storage in spent fuel pools and at-reactor ISFSIs. Chapter 5 addresses impacts at away-from-reactor ISFSIs. As applicable for each resource area, impact determinations were made for each of the three spent fuel storage timeframes: short-term, long-term, and indefinite. The following pages provide a short synopsis of impacts, followed by summary tables (Tables ES-3 and ES-4). At-reactor impacts of continued storage are addressed first, followed by away-from-reactor

Executive Summary

impacts. For some resource areas, the impact determination language is specific to the authorizing regulation, executive order, or guidance.

ES.16.1 Environmental Impacts of At-Reactor Spent Fuel Storage

ES.16.1.1 Land Use

Short-Term Storage. Impacts would be SMALL. Continued at-reactor storage in a spent fuel pool or ISFSI would not require disturbance of any new land or result in operational or maintenance activities that would change land use.

Long-Term Storage. Impacts would be SMALL. Long-term storage at an at-reactor ISFSI would not result in operational or maintenance activities that would change land-use conditions. Construction of a DTS and replacement of an ISFSI and a DTS after 100 years would impact a small fraction of the land committed for a nuclear power plant.

Indefinite Storage. Impacts would be SMALL. Impacts would be similar to long-term impacts—a small fraction of land would be impacted and land-use conditions would not change. Older ISFSIs and DTS facilities would be demolished, and that land would be reclaimed or reused as part of the cyclic replacements.

ES.16.1.2 Socioeconomics

Short-Term Storage. Impacts would be SMALL. A small number of workers would be required to maintain and monitor spent fuel pools and an at-reactor ISFSI, tax payments to local jurisdictions would continue, and there would be no increased demand for housing and public services.

Long-Term Storage. Impacts would be SMALL. The construction of a DTS would take about 1 to 2 years and the size of the construction and ISFSI replacement and operations workforce would be small. Tax payments would continue and would remain relatively constant at post-reactor operations levels. Additionally, there would be no increased demand for housing and public services.

Indefinite Storage. Impacts would be SMALL. Impacts would be similar to those described for long-term storage. The workforce required for monitoring and replacement of DTS facilities and ISFSIs would be small. Property tax revenue would continue as long as spent fuel remains onsite.

ES.16.1.3 Environmental Justice

Short-Term Storage. Continued maintenance and monitoring of spent fuel pools and at-reactor ISFSIs would have minimal human health and environmental effects on all populations including minority and low-income populations. Overall human health and environmental effects from continued short-term spent fuel storage would be limited in scope and SMALL for all populations. Therefore, minority and low-income populations are not expected to experience disproportionately high and adverse human health and environmental effects from the continued short-term storage of spent fuel.

Long-Term Storage. Continued maintenance and monitoring of spent fuel in at-reactor ISFSIs would have minimal human health and environmental effects on all populations including minority and low-income populations near these storage facilities. Overall human health and environmental effects from continued long-term spent fuel storage would be limited in scope and SMALL for all populations, except for historic and cultural resources, which would be SMALL to LARGE. Therefore, minority and low-income populations are not expected to experience disproportionately high and adverse human health and environmental effects from the continued long-term storage of spent fuel.

Indefinite Storage. Indefinite maintenance and monitoring of spent fuel in at-reactor ISFSIs would have minimal human health and environmental effects on all populations including minority and low-income populations near these storage facilities. Overall human health and environmental effects during indefinite storage of spent fuel would be the same as those described for long-term storage, except for the effects of nonradioactive waste generation and disposal, which would be SMALL to MODERATE. Therefore, minority and low-income populations are not expected to experience disproportionately high and adverse human health and environmental effects from the indefinite storage of spent fuel.

ES.16.1.4 Air Quality

Short-Term Storage. Impacts would be SMALL. Air emission impacts from spent fuel storage activities from spent fuel pools and ISFSIs during short-term storage would be substantially smaller than air emissions during power generation. Air temperature changes near dry casks would be indistinguishable from temperature changes that occur naturally.

Long-Term Storage. Impacts would be SMALL. Construction of a DTS, ongoing operation and maintenance of the storage facilities, and replacement of an ISFSI and DTS after 100 years would result in minor and temporary air emissions.

Indefinite Storage. Impacts would be SMALL. Impacts would be similar to those for long-term storage ISFSI and DTS operations, and replacement activities would result in minor and temporary air emissions.

ES.16.1.5 Climate Change

Short-Term Storage. Impacts would be SMALL. The annual level of greenhouse gases generated during continued storage is a small percentage of the annual levels generated in the United States.

Greenhouse gases are gases that trap heat in the atmosphere. The most common greenhouse gases are carbon dioxide, methane, nitrous oxide, and fluorinated gases. Greenhouse gases contribute to global climate change.

Long-Term Storage. Impacts would be SMALL. Impacts would be similar to short-term impacts, and greenhouse gas emissions would be a small fraction of the overall level in the United States.

Indefinite Storage. Impacts would be SMALL. Greenhouse gas emissions would continue to be similar to long-term impacts; they would be a small fraction of the overall level in the United States.

ES.16.1.6 Geology and Soils

Short-Term Storage. Impacts would be SMALL. Continued spent fuel pool operation is not expected to increase impacts to soil and geology. Impacts to soil from small spills and leaks during operation and maintenance of ISFSIs would be minor because of monitoring and environmental protection regulations. No new land would be disturbed for continued operation of spent fuel pools and ISFSIs.

Long-Term Storage. Impacts would be SMALL. Construction, operation, and replacement of the DTS and ISFSI would have minimal impacts to soils on the small fraction of land committed for the facilities, including soil compaction, soil erosion, and potential leaks of oils, greases, and other construction materials. Ongoing operation and maintenance of ISFSIs and DTSs would not be expected to have any additional impacts above those associated with construction. No impacts to geology would be expected.

Indefinite Storage. Impacts would be SMALL. Impacts would be similar to those for long-term storage. Replacement of ISFSIs and DTS facilities would occur on previously disturbed land and would minimize impacts to soils and geology.

ES.16.1.7 Surface-Water Quality and Use

Short-Term Storage. Impacts would be SMALL. Although unlikely, groundwater contamination could affect surface-water quality (see discussion in Appendix E of the GEIS). Potential impacts to surface-water quality and consumptive use from the continued operation of spent fuel pools and ISFSIs would be less than for normal plant operations.

Long-Term Storage. Impacts would be SMALL. Potential consumptive-use and surface-water quality impacts from construction and operation of a DTS would be minor, and replacement of the DTS and ISFSI would be less intense than assumed for initial construction of these facilities.

Indefinite Storage. Impacts would be SMALL. Impacts would be similar to those for long-term storage. Replacement of ISFSIs and DTS facilities once every 100 years would result in temporary and minimal impacts to surface-water quality and use.

ES.16.1.8 Groundwater Quality and Use

Short-Term Storage. Impacts would be SMALL. Groundwater use would be significantly less than that used during reactor operations. Continued storage of spent fuel could result in nonradiological and radiological impacts to groundwater quality. In the unlikely event a spent fuel pool leak remained undetected for a long period of time, contamination of a groundwater source above a regulatory limit could occur (e.g., a Maximum Contaminant Level for one or more radionuclides). Appendix E of the GEIS contains additional supporting analysis of the environmental impacts from spent fuel pool leaks. The analysis concludes that (1) there is a low probability of a leak of sufficient quantity and duration to affect offsite locations and (2) physical processes associated with radionuclide transport, site hydrologic characteristics, and environmental monitoring programs ensure that impacts from spent fuel pool leaks would be unlikely. Impacts to groundwater from continued storage in ISFSIs would be minimal because ISFSI storage requires minimal water and produces minimal, localized, and easy-to-remediate liquid effluents on or near ground surface.

Long-Term Storage. Impacts would be SMALL. Construction of a DTS would require minimal groundwater use. With regard to storage facility-replacement activities, groundwater consumptive use and quality impacts would be similar to those for initial construction of the facilities, and would be minor and temporary.

Indefinite Storage. Impacts would be SMALL. Impacts would be similar to those for long-term storage. Once every 100 years, groundwater would be required for demolishing and replacing the ISFSI and DTS facilities. Consumptive use of groundwater and water-quality impacts would be minor and temporary.

ES.16.1.9 Terrestrial Resources

Short-Term Storage. Impacts would be SMALL. Impacts associated with the operation of spent fuel pools would likely be bounded by the impacts analyzed in the License Renewal GEIS for those issues that were addressed generically in the License Renewal GEIS. For the issue of water-use conflicts with terrestrial resources at plants with cooling ponds or cooling towers using makeup water from a river, the NRC determined that the impacts from operating the spent fuel pool during the short-term storage timeframe would be minimal, because the water withdrawal

Executive Summary

requirements for spent fuel pool cooling are considerably lower than those for a power reactor. Impacts associated with operating an at-reactor ISFSI would be minimal and similar to those described in EAs reviewed for preparation of the GEIS (see Table 1-1).

Long-Term Storage. Impacts would be SMALL. Construction, repackaging, and replacement activities for the ISFSI and DTS would have minimal impacts on terrestrial resources. Normal operations and replacement of DTS and ISFSI facilities would not generate significant noise, would not significantly affect the area available for terrestrial wildlife, and would not adversely impact terrestrial environments or their associated plant and animal species.

Indefinite Storage. Impacts would be SMALL. Impacts would be similar to long-term storage impacts. Replacement of the ISFSI and DTS facilities would occur on land near the existing facilities and could be sited on previously disturbed ground and away from terrestrial species and habitat.

ES.16.1.10 Aquatic Ecology

Short-Term Storage. Impacts would be SMALL. Impacts associated with the operation of spent fuel pools would likely be minimal and bounded by the impacts analyzed in the License Renewal GEIS because of the lower withdrawal rates, lower discharge rates, and smaller thermal plume for a spent fuel pool compared to an operating reactor with closed-cycle cooling. Impacts from operation of onsite ISFSIs would be minimal because ISFSIs do not require water for cooling, and ground-disturbing activities would have minimal impacts on aquatic ecology.

Long-Term Storage. Impacts would be SMALL. Construction, repackaging, and replacement activities for the ISFSI and DTS would have minimal impacts on aquatic resources. The ISFSI and DTS would not require water for cooling, would produce minimal gaseous or liquid effluents, and would have minimal impacts on aquatic resources.

Indefinite Storage. Impacts would be SMALL. Activities and impacts to aquatic resources would be similar to those described for long-term storage, although complete repackaging would occur once every 100 years. Replacement of ISFSI and DTS facilities would occur on land near existing facilities and could be sited on previously disturbed ground and away from sensitive aquatic features.

ES.16.1.11 Special Status Species and Habitat

Short-Term Storage. If continued operation of an ISFSI or spent fuel pool could affect Federally listed species or designated critical habitat, and if the criteria are met in 50 CFR Part 402 for initiation or reinitiation of Endangered Species Act (ESA), Section 7 consultation, the NRC would be required to initiate or reinitiate ESA Section 7 consultation with the National Marine

Fisheries Services (NMFS) or U.S. Fish and Wildlife Service (FWS). With regard to spent fuel pools, impacts on State-listed species and marine mammals would most likely be less than those experienced during the licensed life for operation of the reactor because of the smaller size of the spent fuel pool's cooling system and lower water demands when compared to those of an operating reactor. With regard to dry cask storage of spent fuel, given the small size and ability to site ISFSI facilities away from sensitive ecological resources, the NRC concludes that continued storage of spent fuel in at-reactor ISFSIs would likely have minimal impacts on State-listed species, marine mammals, migratory birds, and bald and golden eagles.

Endangered Species Act, Section 7, called "Interagency Cooperation," is the mechanism by which Federal agencies ensure that the actions they take, including those they fund or authorize, do not jeopardize the existence of any listed species. Under Section 7, the NRC must consult with the U.S. Fish and Wildlife Service or National Marine Fisheries Service when any action the NRC carries out, funds, or authorizes (such as through a permit) *may affect* a listed endangered or threatened species.

Long-Term Storage. In addition to routine maintenance and monitoring of ISFSIs, impacts from the construction of a DTS and replacement of the DTS and ISFSIs on special status species and habitat would be minimal because of the small size of the ISFSI and DTS facilities and because no water is required for cooling. The NRC assumes that the ISFSI and DTS facilities could be sited to avoid listed species and critical habitat because of the small size of the construction footprint and sufficient amount of previously disturbed areas on most nuclear power plant sites. Therefore, the NRC concludes that construction of a DTS and the replacement of the DTS and ISFSI would likely have minimal impacts on State-listed species, marine mammals, migratory birds, and bald and golden eagles. In the unlikely situation that the continued operation of an ISFSI could affect Federally listed species or designated critical habitat, and if the criteria are met in 50 CFR Part 402 for initiation or reinitiation of ESA Section 7 consultation, then the NRC would be required to initiate or reinitiate ESA Section 7 consultation with the NMFS or FWS.

Indefinite Storage. Impacts from indefinite storage on State-listed species, marine mammals, migratory birds, and bald and golden eagles would be minimal. The same consultation and any associated mitigation requirements described for the long-term storage timeframe would apply to the construction of the DTS and replacement of the DTS and ISFSI facilities during indefinite storage. In the unlikely situation that the continued operation of an ISFSI could affect Federally listed species or designated critical habitat, and if the criteria are met in 50 CFR Part 402 for initiation or reinitiation of ESA Section 7 consultation, the NRC would be required to initiate or reinitiate ESA Section 7 consultation with the NMFS or FWS.

ES.16.1.12 Historic and Cultural Resources

Short-Term Storage. Impacts would be SMALL. Because no ground-disturbing activities are anticipated during the short-term storage timeframe, impacts to historic and cultural resources associated with continued operations and maintenance would be SMALL.

Long-Term Storage. Impacts would be SMALL to LARGE. Impacts from continued operations and routine maintenance are expected to be SMALL during the long-term storage timeframe, similar to those described in the short-term storage timeframe. NRC authorization to construct and operate a DTS and to replace a specifically licensed at-reactor ISFSI and DTS would constitute Federal actions under NEPA and would require site-specific environmental reviews and compliance with the National Historic Preservation Act of 1966 (NHPA) before making a decision on the licensing action. For generally licensed ISFSIs, impacts could be avoided, minimized or mitigated if the licensee has management plans or procedures that require consideration of these resources prior to ground-disturbing activities. The NRC assumes that the replacement of the at-reactor ISFSI and DTS would be constructed on land near the existing facilities. As discussed below, the NRC recognizes that there is uncertainty associated with the degree of prior disturbance and the resources, if any, present in areas where future ground-disturbing activities (i.e., initial and replacement DTS and replacement ISFSI) could occur. The NRC cannot eliminate the possibility that historic and cultural resources would be affected by construction activities during the long-term timeframe because the initial ISFSI could be located within a less-disturbed area with historic and cultural resources in close proximity. Further, resources may be present that would not have been considered significant at the time the initial facilities were constructed, but could become significant in the future. Therefore, the potential impacts to historic and cultural resources would be SMALL to LARGE. This range takes into consideration routine maintenance and monitoring (i.e., no ground-disturbing activities), the absence or avoidance of historic and cultural resources, and potential ground-disturbing activities that could impact historic and cultural resources. In addition, the analysis considers uncertainties inherent in analyzing this resource area over long timeframes. These uncertainties include any future discovery of previously unknown historic and cultural resources; resources that gain significance within the vicinity and the viewshed (e.g., nomination of a historic district) due to improvements in knowledge, technology, and excavation techniques; and changes associated with predicting resources that future generations will consider significant. If construction of a DTS and replacement of the ISFSI and DTS occurs in an area with no historic or cultural resource present or construction occurs in previously a disturbed area that allows avoidance of historic and cultural resources then impacts would be SMALL. By contrast, a MODERATE or LARGE impact could result if historic and cultural resources are present at a site and, because they cannot be avoided, are impacted by ground-disturbing activities during the long-term timeframe.

Indefinite Storage. Impacts would be SMALL to LARGE. Impacts regarding the replacement of the ISFSI and DTS would be similar to those described in the long-term storage timeframe. The NRC assumes that replacement at-reactor ISFSI and DTS would be constructed on land near the existing facilities. As stated in Section 1.8, the NRC assumes that the land where the original facilities were constructed will be available for replacement facility construction; however, the NRC cannot eliminate the possibility that historic and cultural resources would be affected by construction activities during the indefinite timeframe because the initial and replacement ISFSIs and DTS could be located within a less disturbed area with historic and cultural resources in close proximity. Further, resources may be present that would not have been considered significant at the time the initial or replacement facilities were constructed, but could become significant in the future. Impacts to historic and cultural resources would be SMALL to LARGE. This range takes into consideration routine maintenance and monitoring (i.e., no ground-disturbing activities), the absence or avoidance of historic and cultural resources, and potential ground-disturbing activities that could impact historic and cultural resources. The analysis also considers the uncertainties inherent in analyzing this resource area over long timeframes. These uncertainties include any future discovery of previously unknown historic and cultural resources; resources that gain significance within the vicinity and the viewshed (e.g., nomination of a historic district) due to improvements in knowledge, technology, and excavation techniques, and changes associated with predicting resources that future generations will consider significant. If construction of a DTS and replacement of the ISFSI and DTS occurs in an area with no historic or cultural resource present or construction occurs in previously a disturbed area that allows avoidance of historic and cultural resources then impacts would be SMALL. By contrast, a MODERATE or LARGE impact could result if historic and cultural resources are present at a site and, because they cannot be avoided, are impacted by ground-disturbing activities during the indefinite timeframe.

ES.16.1.13 Noise

Short-Term Storage. Impacts would be SMALL. Spent fuel pool and dry cask storage noise levels, noise duration, and distance between noise sources and receptors would generally not be expected to produce noise impacts noticeable to the surrounding community.

Long-Term Storage. Impacts would be SMALL. Construction of the DTS and replacement of the DTS and ISFSI, although temporary and representing a small portion of the overall time period for spent fuel storage, would generate noise levels that exceed EPA-recommended noise levels. Noise from dry cask storage operations would be infrequent and at lower levels than for construction or replacement activities. Generally, for spent fuel storage, the noise levels, noise duration, and distance between the noise sources and receptors would not be expected to produce noise impacts noticeable to the surrounding community.

Executive Summary

Indefinite Storage. Impacts would be SMALL. Most noise would be generated by construction equipment associated with the replacement of the ISFSI and DTS facilities; impacts would be similar to those during the long-term storage timeframe.

ES.16.1.14 Aesthetics

Short-Term Storage. Impacts would be SMALL. No changes to the visual profile are likely to occur as a result of the continued operation and maintenance of the existing spent fuel pool and at-reactor ISFSI.

Long-Term Storage. Impacts would be SMALL. Periodic construction, replacement, and operation activities would not significantly alter the landscape of an ISFSI.

Indefinite Storage. Impacts would be SMALL. Impacts would be similar to long-term storage and would not significantly alter the landscape of an ISFSI.

ES.16.1.15 Waste Management

Short-Term Storage. Impacts would be SMALL. Continued at-reactor storage of spent fuel would generate much less low-level, mixed, and nonradioactive waste than an operating facility, and licensees would continue to implement Federal and State regulations and requirements regarding proper management and disposal of wastes.

Long-Term Storage. Impacts would be SMALL. The replacement of the ISFSI, repackaging of spent fuel canisters, and construction, operation, and replacement of the DTS would generate a fraction of the low-level waste (LLW) generated during reactor decommissioning, and LLW would continue to be managed according to Federal and State regulations. The quantity of mixed waste generated from long-term storage would be a small fraction of that generated during the licensed life of the reactor. Although large amounts of nonradioactive waste would be generated by replacement of dry cask storage facilities, it would still be less than the waste generated during reactor decommissioning and would not likely have a noticeable impact on local or regional landfill capacity and operations.

Low-level waste is a general term for a wide range of items that have become contaminated with radioactive material or have become radioactive through exposure to neutron radiation. The radioactivity in these wastes can range from just above natural background levels to much higher levels, such as seen in parts from inside the reactor vessel in a nuclear power reactor.

Mixed waste contains two components: low-level radioactive waste and hazardous waste, as defined in EPA regulations.

Indefinite Storage. Impacts would be SMALL to MODERATE. It is expected that sufficient LLW disposal capacity would be made available when needed. A relatively small quantity of mixed waste would be generated from indefinite storage and proper management and disposal

regulations would be followed. The amount of nonradioactive waste that would be generated and impacts to nonradioactive waste landfill capacity are difficult to accurately estimate for the indefinite storage timeframe and therefore could result in SMALL to MODERATE impacts.

ES.16.1.16 Transportation

Short-Term Storage. Impacts would be SMALL. A low volume of traffic and shipping activities is expected with the continued storage of spent fuel in spent fuel pools and at-reactor ISFSIs.

Long-Term Storage. Impacts would be SMALL. There would be small workforce requirements for continued storage and aging management activities (relative to the power plant workforce) and a low frequency of supply shipments and shipments of LLW from DTS activities, continued dry cask storage operations, and ISFSI and DTS replacement activities.

Indefinite Storage. Impacts would be SMALL. There would be no significant changes to the annual magnitude of traffic or waste shipments that were identified for long-term storage.

ES.16.1.17 Public and Occupational Health

Short-Term Storage. Impacts would be SMALL. Annual public and occupational doses would be maintained below the annual dose limits established by 10 CFR Part 72 for the public and 10 CFR Part 20 for occupational personnel. Licensed facilities would also be required by the above regulations to maintain an as-low-as-is-reasonably-achievable (ALARA) program, which would likely reduce the doses even further. Appendix E of the GEIS provides additional information to support the environmental impact determination with respect to leaks from spent fuel pools on public health. Public health regulatory limits could be exceeded in the unlikely event a spent fuel pool leak remained undetected for a long period of time. Preventive maintenance activities would be conducted in accordance with Occupational Safety and Health Agency requirements and risks to occupational health and safety would be infrequent and minor.

ALARA is an acronym for "as low as (is) reasonably achievable," which means making every reasonable effort to maintain exposures to ionizing radiation as far below the dose limits as practical.

Long-Term Storage. Impacts would be SMALL. Public and occupational doses would be maintained well below the dose limits established by 10 CFR Part 72 for the public and 10 CFR Part 20 for occupational personnel. Licensed facilities would also be required by these regulations to maintain an ALARA program to ensure radiation doses are maintained as low as is

10 CFR Part 20 contains the NRC's radiation protection regulations.
10 CFR Part 72 contains the NRC's regulations for licensing storage facilities for spent fuel and other radioactive waste.

Executive Summary

reasonably achievable. Construction activities for the DTS would be conducted in accordance with Occupational Safety and Health Agency requirements, and once in operation, ISFSI preventive maintenance would be infrequent and minor.

Indefinite Storage. Impacts would be SMALL. Impacts to public and occupation health are expected to be similar to those from long-term spent fuel storage activities.

ES.16.1.18 Environmental Impacts of Postulated Accidents

Because the accident risks for spent fuel pool storage only apply during the short-term timeframe and the accident risks for dry cask storage are substantially the same across the three timeframes, the GEIS does not present the various accident types by timeframe, but rather by accident type (i.e., design basis and severe) and storage facility type (i.e., spent fuel pool and dry cask storage system).

Design Basis Accidents in Spent Fuel Pools. Impacts would be SMALL. The postulated design basis accidents considered in this GEIS for spent fuel pools include hazards from natural phenomena, such as earthquakes, floods, tornadoes, and hurricanes; hazards from activities in the nearby facilities; and fuel handling-related accidents. In addition, potential effects of climate change are also considered. Based on the assessment in Section 4.18, the environmental impacts of these postulated accidents involving continued storage of spent fuel in pools are SMALL because all important safety structures, systems, and components involved with the spent fuel storage are designed to withstand these design basis accidents without compromising the safety functions.

A **design basis accident** is a postulated accident that a nuclear facility must be designed and built to withstand without loss to the systems, structures, and components necessary to ensure public health and safety.

Design Basis Accidents in Dry Cask Storage Systems and Dry Transfer Systems. Impacts would be SMALL. All NRC-licensed dry cask storage systems are designed to withstand all postulated design basis accidents without any loss of safety functions. A DTS or a facility with equivalent capabilities may be needed to enable retrieval of spent fuel for inspection or repackaging. Licensees of DTS facilities are required to design the facilities so that all safety-related structures, systems, and components can withstand the design basis accidents without compromising any safety functions. Based on the assessment, the environmental impact of the design basis accidents is SMALL because safety-related structures, systems, and components are designed to function in case of these accidents.

A **severe accident** is a type of accident that may challenge safety systems at a level much higher than expected.

Severe Accidents in Spent Fuel Pools. Probability-weighted impacts would be SMALL. A spent fuel pool may encounter severe events, such as loss of offsite power or beyond design basis earthquakes. Although it is theoretically possible that these events may lead to loss of spent

fuel pool cooling function resulting in a spent fuel pool fire, the likelihood of such events is extremely small. Additional discussion about spent fuel pool fires can be found in Appendix F.

Severe Accidents in Dry Cask Storage Systems. Probability-weighted impacts would be SMALL. Although some handling accidents such as a postulated drop of a canister could exceed NRC's public dose standards, the likelihood of the event is very low. Therefore, the environmental impact of severe accidents in a dry storage facility is SMALL.

ES.16.1.19 Potential Acts of Sabotage or Terrorism

Although the NRC believes that NEPA does not require such an analysis and that it is only required for facilities within the Ninth Circuit, the NRC finds that even though the environmental consequences of a successful attack on a spent fuel pool beyond the licensed life for operation of a reactor are large, the very low probability of a successful attack ensures that the environmental risk is SMALL. Similarly, for an operational ISFSI or DTS during continued storage, the NRC finds that the environmental risk of a successful radiological sabotage attack is SMALL.

Table ES-3. Summary of Environmental Impacts of Continued At-Reactor Storage

Resource Area	Short-Term Storage	Long-Term Storage	Indefinite Storage
Land Use	SMALL	SMALL	SMALL
Socioeconomics	SMALL	SMALL	SMALL
Environmental Justice	Disproportionately high and adverse impacts are not expected.		
Air Quality	SMALL	SMALL	SMALL
Climate Change	SMALL	SMALL	SMALL
Geology and Soils	SMALL	SMALL	SMALL
Surface Water			
Quality	SMALL	SMALL	SMALL
Consumptive Use	SMALL	SMALL	SMALL
Groundwater			
Quality	SMALL	SMALL	SMALL
Consumptive Use	SMALL	SMALL	SMALL
Terrestrial Resources	SMALL	SMALL	SMALL
Aquatic Ecology	SMALL	SMALL	SMALL
Special Status Species and Habitat	Impacts for Federally listed threatened and endangered species and Essential Fish Habitat would be determined as part of the consultations for the ESA and the Magnuson–Stevens Fishery Conservation and Management Act.		

Table ES-3. Summary of Environmental Impacts of Continued At-Reactor Storage (cont'd)

Resource Area	Short-Term Storage	Long-Term Storage	Indefinite Storage
Historic and Cultural Resources	SMALL	SMALL to LARGE	SMALL to LARGE
Noise	SMALL	SMALL	SMALL
Aesthetics	SMALL	SMALL	SMALL
Waste Management			
Low-Level Waste	SMALL	SMALL	SMALL
Mixed Waste	SMALL	SMALL	SMALL
Nonradioactive Waste	SMALL	SMALL	SMALL to MODERATE
Transportation	SMALL	SMALL	SMALL
Public and Occupational Health	SMALL	SMALL	SMALL
Accidents	SMALL	SMALL	SMALL
Sabotage or Terrorism	SMALL	SMALL	SMALL

ES.16.2 Environmental Impacts of Away-From-Reactor Spent Fuel Storage

No away-from-reactor ISFSIs of the size considered in Chapter 5 (40,000 metric tons uranium) have been constructed in the United States. For the analysis of environmental impacts in Chapter 5, the NRC assumes that construction and operation of an away-from-reactor ISFSI would be similar to that proposed for the Private Fuel Storage Facility on the Reservation of the Skull Valley Band of Goshute Indians in Tooele County, Utah. The NRC previously analyzed the environmental impacts of constructing and operating the Private Fuel Storage Facility in NUREG-1714. For the analysis of continued storage at an away-from-reactor ISFSI, the term ISFSI refers to all of the original facilities that would be built (i.e., storage pads, casks, and canister transfer building).

ES.16.2.1 Land Use

Short-Term Storage. Impacts would be SMALL. Construction of an ISFSI would change the nature of land use within the site boundary and along access corridors. While this change could be qualitatively substantial (e.g., from agricultural to industrial), the land parcel is assumed to be sufficiently remote and small that no quantitatively significant impact would occur.

Long-Term Storage. Impacts would be SMALL. Construction of a DTS would disturb a small portion of the land committed for an away-from-reactor storage facility. To minimize land-use impacts from replacement of the ISFSI and DTS facilities, the replacement facilities would likely be constructed on land near the existing facilities, and the old facilities would likely be demolished and the land reclaimed.

Indefinite Storage. Impacts would be SMALL. Only a small portion of the total land committed for development of an away-from-reactor ISFSI is required to support continued operations, including periodic maintenance or replacement of equipment and repackaging of fuel. Replacement of the away-from-reactor ISFSI and DTS every 100 years would likely occur on land near the existing facilities.

ES.16.2.2 Socioeconomics

Short-Term Storage. Adverse impacts would be SMALL. Based on the small workforce required for construction and operations of an away-from-reactor facility, and any associated indirect impacts to public services and housing, the impacts of construction and operation of a storage facility on those resources would be minor. Beneficial impacts to the economy could be LARGE in some rural economies.

Long-Term Storage. Adverse impacts would be SMALL. Construction of a DTS would require a workforce smaller than the workforce required for construction of an away-from-reactor ISFSI. The labor force required for maintenance and replacement activities of an ISFSI and DTS would not be expected to exceed the labor force required for construction of the storage facility as a whole. Beneficial impacts to the economy could be LARGE in some rural economies.

Indefinite Storage. Adverse impacts would be SMALL. If no repository becomes available, operational and replacement activities would continue, beneficial impacts to the economy could be LARGE in some rural economies.

ES.16.2.3 Environmental Justice

Short-Term Storage. The process of siting an away-from-reactor ISFSI would be expected to ensure that environmental justice concerns are addressed prior to licensing. Overall human health and environmental effects from construction of the ISFSI and from continued storage during the short-term timeframe would be limited in scope and SMALL for all populations, except for air quality, terrestrial resources, aesthetics, historic and cultural resources, and socioeconomic and traffic conditions. Minority and low-income populations are not expected to experience disproportionately high and adverse human health and environmental effects from the construction and operation of an away-from-reactor ISFSI. Should the NRC receive an application for a proposed away-from-reactor ISFSI, a site-specific NEPA analysis would be conducted, and that analysis would include consideration of environmental justice impacts.

Long-Term Storage. The impacts from constructing the DTS within the ISFSI protected area would be within the envelope of impacts from the construction of the away-from-reactor ISFSI. Overall human health and environmental effects of storing spent fuel during the long-term timeframe would be limited in scope and SMALL for all populations, except for aesthetics, historic and cultural resources, socioeconomic, and traffic conditions. Given the passive nature of storage operations, the short amount of time required for DTS construction and replacement

Executive Summary

of the ISFSI and DTS and the ongoing monitoring and maintenance, minority and low-income populations are not expected to be experience disproportionately high and adverse human health and environmental impacts.

Indefinite Storage. Overall human health and environmental effects of storing spent fuel during the indefinite timeframe would be the same as those described for long-term storage, except for nonradioactive waste generation and disposal. Based on this information, minority and low-income populations are not expected to experience disproportionately high and adverse human health and environmental effects from the operation and replacement of the ISFSI and DTS.

ES.16.2.4 Air Quality

Short-Term Storage. Impacts would be SMALL to MODERATE. Construction of an away-from-reactor ISFSI would result in minimal emissions, but construction of the rail spur could produce temporary and localized impacts that would be noticeable. ISFSI operations generate minor levels of air emissions but not enough to be classified as a “major stationary source” of emissions as defined in Federal air quality regulations. Locomotives transporting spent fuel to an away-from-reactor ISFSI would emit exhaust pollutants in a distributed manner along the transport route.

Long-Term Storage. Impacts would be SMALL. Operational activities are expected to be of relatively short duration and limited in extent. The DTS is a relatively small facility, and the air quality impacts associated with construction would be less than those associated with the original construction of the ISFSI. Replacement of the DTS and ISFSI and maintenance of the rail spur would involve only a fraction of the air emissions associated with initial construction of an ISFSI. Exhaust from vehicles would not be expected to noticeably affect air quality for the region.

Indefinite Storage. Impacts would be SMALL. Indefinite storage would consist of the same short-duration and limited-extent activities and would result in the same impact magnitudes as described for long-term storage except that they would continue indefinitely into the future.

ES.16.2.5 Climate Change

Short-Term Storage. Impacts would be SMALL. Average annual greenhouse gas emissions associated with building and operating an ISFSI as well as transportation (e.g., commuters, supplies, waste materials, and spent fuel) would be equivalent to the annual emissions from about 1,640 passenger vehicles.

Long-Term Storage. Impacts would be SMALL. Construction of a DTS, replacement of dry casks and pads, and maintenance activities would likely involve only a fraction of the greenhouse gas emissions associated with the original construction of the ISFSI.

Indefinite Storage. Impacts would be SMALL. Greenhouse gas emissions would continue to be similar to long-term impacts.

ES.16.2.6 Geology and Soils

Short-Term Storage. Impacts would be SMALL. The land required to construct an ISFSI would be relatively small, and soil erosion controls would minimize impacts.

Long-Term Storage. Impacts would be SMALL. Construction of a DTS would have minimal impacts to geology and soil because of the small size of the facility. Replacement of the ISFSI pads and supporting facilities would likely occur on land near the existing facilities. The old facilities would likely be demolished, and the land would likely be reclaimed.

Indefinite Storage. Impacts would be similar to long-term storage, SMALL. Replacement of ISFSI and DTS facilities would occur on previously disturbed land and would minimize impacts to soils and geology.

ES.16.2.7 Surface-Water Quality and Use

Short-Term Storage. Impacts would be SMALL. Best management practices would be implemented during construction of an ISFSI to address stormwater flows, soil erosion, and siltation. Stormwater control measures would be required to comply with State-enforced water-quality permits. Construction and operation of an ISFSI would require very little consumptive use of water.

Long-Term Storage. Impacts would be SMALL. Given the relatively smaller size of a DTS as compared to an ISFSI, much less water would be required to build a DTS. Consumptive use and surface-water quality impacts would be no greater than those identified for initial construction of the storage facilities.

Indefinite Storage. Impacts would be SMALL. Impacts would be similar to those for long-term storage. Replacement of ISFSIs and DTS facilities once every 100 years would result in temporary and minimal impacts to surface-water quality and use.

ES.16.2.8 Groundwater Quality and Use

Short-Term Storage. Impacts would be SMALL. Methods necessary to control impacts to groundwater quality during construction and operation of an ISFSI are well understood and State-issued permits typically require the implementation of such controls. Construction and operation of an ISFSI would require very little consumptive use of water.

Long-Term Storage. Impacts would be SMALL. Impacts on groundwater from a DTS would be no larger than those considered for construction of the ISFSI. Likewise, the impacts of replacing portions of the ISFSI over time would be no more than the impacts of the initial construction of the facility, and would likely occur over a longer period of time.

Executive Summary

Indefinite Storage. Impacts would be SMALL. Impacts would be similar to those for long-term storage. Once every 100 years, groundwater may be required when demolishing and replacing the ISFSI and DTS facilities. Consumptive use of groundwater and water-quality impacts would be minor.

ES.16.2.9 Terrestrial Resources

Short-Term Storage. Impacts would be SMALL to MODERATE. Land area permanently disturbed for construction of an away-from-reactor dry cask storage facility would be relatively small, and any impacts to wetlands would be addressed under the Clean Water Act. However, construction could have some noticeable impacts to terrestrial resources, such as habitat loss, displacement of wildlife, and incremental habitat fragmentation. ISFSI operations would have minimal impacts on terrestrial resources.

Long-Term Storage. Impacts would be SMALL. Impacts from construction of a DTS would be significantly less than those impacts expected from construction and operation of an ISFSI. Because of its relatively small construction footprint, the DTS could be sited on previously disturbed ground and away from sensitive terrestrial resources. Impacts from operational activities would be minor. Replacement activities would occur once about every 100 years, and would likely occur near existing facilities.

Indefinite Storage. Impacts would be SMALL. Replacement activities are not expected to add additional impacts beyond those impacts expected for initial construction of the away-from-reactor ISFSI and DTS. Operation of away-from reactor ISFSIs would not require any additional land use beyond that set aside for original construction of the facility.

ES.16.2.10 Aquatic Ecology

Short-Term Storage. Impacts would be SMALL. Construction and operation of an away-from-reactor ISFSI would require limited water supplies, and effluents, if any, would be limited to stormwater and treated wastewater. Impacts to aquatic resources would tend to be limited by certain factors, including the land area permanently disturbed would be relatively small; water use for the construction and operation of the site would be limited; and any impacts from discharges to water bodies would need to be addressed under the Clean Water Act, which requires licensees to obtain a National Pollutant Discharge Elimination System permit for any discharges to water bodies.

Long-Term Storage. Impacts would be SMALL. Building a DTS, and transferring, handling, and aging management of spent fuel at an away-from-reactor ISFSI could result in ground-disturbing activities that would have impacts similar to or less than impacts associated with the original construction of the ISFSI. Replacement activities would likely occur near existing facilities, and aquatic disturbances would result in relatively short-term impacts and aquatic environs would recover naturally.

Indefinite Storage. Impacts would be SMALL. Activities associated with demolishing old facilities and building replacement facilities about once every 100 years could result in minimal, short-term impacts to aquatic resources. Impacts associated with ISFSI operation and maintenance would also be small.

ES.16.2.11 Special Status Species and Habitat

Short-Term Storage. Impacts from the initial construction and ongoing operation and maintenance of dry cask storage facilities to State-listed species, marine mammals, migratory birds, and bald and golden eagles would range from minimal to noticeable, which would be similar to those described for terrestrial and aquatic resources, with any noticeable impacts resulting from the construction of the ISFSI. An away-from-reactor ISFSI could be sited to avoid adversely affecting special status species and habitat. The NRC would assess the impacts to Federally listed species and designated critical habitat from an away-from-reactor ISFSI and DTS in a site-specific review before the facility is initially constructed and afterwards if an activity meets the criteria in 50 CFR 402 for initiation or reinitiation of Section 7 consultation.

Long-Term Storage. During the long-term storage timeframe, initial construction of the DTS and replacement of the casks, pads, and the DTS would result in impacts that would be less than initial construction impacts because replacement activities would occur within the facility's operational area near existing facilities. The NRC would assess the impacts to Federally listed species and designated critical habitat from an away-from-reactor ISFSI and DTS in a site-specific review before the facility is initially constructed and afterwards if an activity meets the criteria in 50 CFR Part 402 for initiation or reinitiation of Section 7 consultation.

Indefinite Storage. Impacts to special status species and habitat from continued operation of away-from-reactor ISFSIs if a repository never becomes available would be similar to those described for the long-term storage timeframe. The same operations and maintenance activities would occur repeatedly because the spent fuel remains at the facility indefinitely. The NRC would assess the impacts to Federally listed species and designated critical habitat from an away-from-reactor ISFSI and DTS in a site-specific review before the facility is initially constructed and afterwards if an activity meets the criteria in 50 CFR Part 402 for initiation or reinitiation of Section 7 consultation.

ES.16.2.12 Historic and Cultural Resources

Short-Term Storage. Impacts would be SMALL to LARGE. Impacts to historic and cultural resources would vary depending on what resources are present, but could be minimized because (1) the land area disturbed would be relatively small, (2) site selection and placement of facilities on the site could be adjusted to minimize or

Section 106 of the National Historic Preservation Act of 1966 requires Federal agencies to take into account the effects of their undertakings on historic properties.

Executive Summary

avoid impacts to historic and cultural resources because the facility does not depend on significant water supply and has limited electrical power needs, and (3) potential impacts could also be minimized through development of agreements, license conditions, and implementation of the licensees' historic and cultural resource management plans and procedures to protect known historic and cultural resources and address inadvertent discoveries. Additionally, should the NRC receive an application for a proposed away-from-reactor ISFSI, the NRC would conduct a site-specific assessment of potential impacts to historic and cultural resources under Section 106 of the NHPA. Impacts from continued operations and routine maintenance during the short-term timeframe would be small because no ground-disturbing activities are expected; therefore, impacts would be SMALL. In most, but not all instances, placement of storage facilities on the site can be adjusted to minimize or avoid impacts on any historic and cultural resources in the area. However, the NRC recognizes that this is not always possible. Therefore, the NRC concludes that the potential impacts on historic and cultural resources could range from SMALL to LARGE, depending on site-specific factors.

Long-Term Storage. Impacts would be SMALL to LARGE. Impacts from continued operations, routine maintenance, replacement of the facilities at an away-from-reactor ISFSI, and potential construction, operation, and replacement of a DTS would vary depending on what resources are present, proposed land disturbance, and if the licensee has management plans and procedures that are protective of historic and cultural resources. Additionally, the construction of a DTS and replacement of an ISFSI and the DTS would be Federal actions that would require the NRC to conduct a site-specific assessment of potential impacts to historical and cultural resources under Section 106 of NHPA. The NRC assumes that the replacement of the ISFSI and DTS would be constructed on land near the existing facilities. The NRC recognizes that there is uncertainty associated with the degree of prior disturbance and the resources, if any, are present in areas where future ground-disturbing activities could occur. The NRC cannot eliminate the possibility that historic and cultural resources would be affected by construction activities because the initial ISFSI could be located within a less-disturbed area with historic and cultural resources in close proximity. Further, resources may be present after initial construction of the away-from-reactor ISFSI that would not have been considered significant at the time the initial or replacement facilities were constructed, but could become significant in the future. This range takes into consideration routine maintenance and monitoring (i.e., no ground-disturbing activities), the absence or avoidance of historic and cultural resources, and potential ground-disturbing activities that impact historic and cultural resources. The analysis also considers uncertainties inherent in analyzing this resource over long timeframes. These uncertainties include any future discovery of previously unknown historic and cultural resources; resources that gain significance within the vicinity and the viewshed (e.g., nomination of a historic district) due to improvements in knowledge, technology, and excavation techniques; and changes associated with predicting resources that would be significant to future generations. If construction of a DTS and replacement of the ISFSI and DTS occurs in an area with no historic or cultural resource present or construction occurs in previously a disturbed area that allows

avoidance of historic and cultural resources then impacts would be SMALL. By contrast, a MODERATE or LARGE impact could result if historic and cultural resources are present at a site and, because they cannot be avoided, are impacted by ground-disturbing activities during the long-term timeframe.

Indefinite Storage. Impacts would be SMALL to LARGE. Impacts would be similar to those described for the long-term storage timeframe. The NRC assumes that the replacement of the ISFSI and DTS would be constructed on land near the existing facilities. As stated in Section 1.8, the NRC assumes that the land where the original facilities were constructed will be available for replacement facility construction; however, the NRC cannot eliminate the possibility that historic and cultural resources will be affected by construction activities during the indefinite timeframe because there is uncertainty associated with the degree of prior disturbance and what resources, if any, are present in areas where future ground-disturbing activities (e.g., initial and replacement DTS and replacement ISFSI) could occur. Further, significant resources may be present that were not considered significant at the time the initial or replacement facilities were constructed. Potential impacts to historic and cultural resources during the indefinite storage timeframe would range from SMALL to LARGE. This range takes into consideration routine maintenance and monitoring (i.e., no ground-disturbing activities), the absence or avoidance of historic and cultural resources, and potential ground-disturbing activities that could impact historic and cultural resources. The analysis also considers uncertainties inherent in analyzing this resource area over long timeframes. These uncertainties include any future discovery of previously unknown historic and cultural resources; resources that gain significance within the vicinity and the viewshed (e.g., nomination of a historic district) due to improvements in knowledge, technology, and excavation techniques; and changes associated with predicting resources that future generations would consider significant. If construction of a DTS and replacement of the ISFSI and DTS occurs in an area with no historic or cultural resource present or construction occurs in previously a disturbed area that allows avoidance of historic and cultural resources then impacts would be SMALL. By contrast, a MODERATE or LARGE impact could result if historic and cultural resources are present at a site and, because they cannot be avoided, are impacted by ground-disturbing activities during the indefinite timeframe.

ES.16.2.13 Noise

Short-Term Storage. Impacts would be SMALL. Noise impacts for an away-from-reactor ISFSI could exceed EPA-recommended levels during some portions of construction and operation; however, noise impacts would be short in duration and intermittent.

Long-Term Storage. Impacts would be SMALL. Noise impacts from continued operation and routine maintenance of an away-from-reactor ISFSI would be minimal. Impacts from construction of a DTS and replacement of the DTS and ISFSI would be similar to those for initial construction of an ISFSI. These construction and replacement activities would be intermittent and short in duration, and noticeable noise levels would be limited to the nearest receptors.

Executive Summary

Indefinite Storage. Impacts would be SMALL. Impacts would be similar to those associated with the long-term storage timeframe. Ongoing operation, maintenance, and replacement activities would have minimal noise impacts.

ES.16.2.14 Aesthetics

Short-Term Storage. Impacts would be SMALL to MODERATE. Potential impacts to aesthetic resources would include visibility of facility buildings, dry storage pads and canisters, and the rail line and trains from across scenic water bodies, roadways, or from higher elevations. Lighting of the facility would increase visibility. If constructed in an area with no prior industrial development, the ISFSI could impact the local viewshed, and scenic appeal of the site would be noticeably changed when viewed from various locations. Impacts could be minimal if the ISFSI is built in a previously disturbed area.

Long-Term Storage. Impacts would be SMALL to MODERATE. Aesthetic impacts from transferring and handling spent fuel and aging management activities at an away-from-reactor ISFSI are anticipated to be similar to the impacts for initial construction and short-term operation of the ISFSI. Periodic construction, demolition, and operation activities required for aging management would not significantly alter the pre-existing impacts on aesthetic resources.

Indefinite Storage. Impacts would be SMALL to MODERATE. The same operations and maintenance activities that are described for the long-term storage timeframe occur repeatedly because the spent fuel remains at the facility indefinitely.

ES.16.2.15 Waste Management

Short-Term Storage. Impacts would be SMALL. Construction activities would generate excavation and construction debris, vegetation debris, and backfill. Operation of an away-from-reactor ISFSI would involve limited waste generating activities. Small quantities of LLW may be generated during routine operation and maintenance. Little to no mixed waste generation would be expected. Small quantities of nonradioactive waste would be generated. All wastes would be managed and disposed of according to regulatory requirements.

Long-Term Storage. Impacts would be SMALL. Routine maintenance would generate minimal quantities of waste. Construction and operation of a DTS and replacement of ISFSI and DTS facilities at an away-from-reactor ISFSI would generate LLW and nonradioactive waste. Although the exact amount of LLW and nonradioactive waste depends on the level of contamination, the quantity of LLW generated from the replacement of the ISFSI and DTS is expected to be comparable to the LLW generated during reactor decommissioning, which was determined to have a SMALL impact in the License Renewal GEIS. Although a large amount of nonradioactive waste would be generated by replacement of the ISFSI and DTS, it would not likely have a noticeable impact on total nonradioactive waste disposal capacity.

Indefinite Storage. Impacts would be SMALL to MODERATE. LLW, mixed waste, and nonradioactive waste would continue to be generated indefinitely, and there could be noticeable impacts on the local and regional landfill capacity for nonradioactive waste disposal.

ES.16.2.16 Transportation

Short-Term Storage. Impacts would be SMALL to MODERATE. The environmental impacts of transportation include impacts to regional traffic from commuting workers, supply shipments, shipments of spent fuel to the ISFSI, and shipments of nonradioactive and radiological waste. Impacts to traffic from workers commuting to and from the away-from-reactor storage site depend on the size of the workforce, the capacity of the local road network, traffic patterns, and the availability of alternative commuting routes to and from the facility. The majority of impacts would be associated with the traffic during the initial construction of the ISFSI.

Shipment of spent fuel from nuclear power plants to the ISFSI would be required to comply with NRC and the U.S. Department of Transportation regulations. Radiological impacts to the public and workers from spent fuel shipments from a reactor have previously been evaluated by the NRC (in Table S-4 of 10 CFR 51.52) and were found to be small.

Long-Term Storage. Impacts would be SMALL to MODERATE. Construction of a DTS would require a smaller workforce than the initial construction of the ISFSI, so transportation impacts from workers commuting would be less, but may still be noticeable. Shipments of LLW generated by maintenance and replacement activities would be regulated by NRC and Department of Transportation requirements and impacts to traffic and to public and worker radiological and nonradiological safety would be minimal.

Indefinite Storage. Impacts would be SMALL to MODERATE. Annual transportation activities and associated environmental impacts would be similar to that analyzed for the long-term storage timeframe.

ES.16.2.17 Public and Occupational Health

Short-Term Storage. Impacts would be SMALL. Nonradiological health impacts from the construction of an away-from-reactor ISFSI include normal hazards associated with construction, such as pollutants (e.g., dust), and fatal and nonfatal occupational injuries (e.g., falls and overexertion). Impacts would be minor and similar to an industrial facility of similar size. Public and occupation radiological doses would be maintained significantly below the

<p>Table S-4 in 10 CFR 51.52 summarizes the environmental impacts of transportation of fuel and waste to and from a nuclear power plant. Data supporting the determinations in Table S-4 is contained in the NRC's <i>Environmental Survey of Transportation of Radioactive Materials to and from Nuclear Power Plants</i>, WASH-1238, December 1972, and Supp. 1 NUREG-75/038, April 1975.</p>
--

Executive Summary

dose limits established by 10 CFR Part 72 and 10 CFR Part 20. Licensed facilities would also be required by those regulations to maintain an ALARA program, which would likely reduce the doses even further.

Long-Term Storage. Impacts would be SMALL. Nonradiological health impacts associated with replacement activities would be similar those for the original construction of the facility, although replacement activities would take place over a longer period of time. Public and occupational radiological doses would be maintained significantly below the dose limits established by 10 CFR Part 72 and 10 CFR Part 20. In addition, the dry cask storage facility would be required to maintain an ALARA program that would likely further reduce radiological doses. Operation of the DTS would involve increased doses to works and a very small increase in dose levels at the site boundary; however, the licensee would still be required to comply with regulations limiting dose.

Indefinite Storage. Impacts would be SMALL. For the indefinite storage timeframe, the types of activities (construction, operation, and replacement) and associated health impacts would remain the same as those for the long-term storage timeframe.

ES.16.2.18 Environmental Impacts of Postulated Accidents

Impacts would be SMALL. Consideration of accidents at an away-from-reactor ISFSI for all three storage timeframes is similar to those for at-reactor ISFSIs (described in Chapter 4). The postulated accident analysis in the GEIS is applicable for all three timeframes (short-term, long-term, and indefinite). The NRC regulations in 10 CFR Part 72 require that structures, systems, and components important to safety will be designed to withstand the effects of natural phenomena (such as earthquakes, tornadoes, and hurricanes) and human-induced events without loss of capability to perform those safety functions. The NRC siting regulations also require applicants to take into consideration, among other things, physical characteristics of sites that are necessary for the safety analysis or that may have an impact on plant design (such as the design basis earthquake). All these factors are considered in determining the acceptability of the site and design criteria of a proposed dry cask storage facility. The GEIS analysis considered an accident scenario in which wind-borne missiles damage the concrete overpack of a dry cask. This accident would result in only slightly higher occupational doses and only negligible increases in radiological doses at the boundary of the site. The analysis also considered an accident resulting in a dry cask leaking, and determined that radiological doses would still be below the limits in 10 CFR Part 20 and 10 CFR Part 72.

ES.16.2.19 Potential Acts of Sabotage or Terrorism

The consideration of acts of sabotage or terrorism at an away-from-reactor ISFSI for all three storage timeframes are similar to those for at-reactor ISFSIs (described in Chapter 4). The

probability and consequences of a successful attack on an away-from-reactor ISFSI or DTS are low; therefore, the environmental risk is SMALL.

Table ES-4. Summary of Environmental Impacts of Away-From-Reactor Spent Fuel Storage

Resource Area	Short-Term Storage	Long-Term Storage	Indefinite Storage
Land Use	SMALL	SMALL	SMALL
Socioeconomics	SMALL (adverse) to LARGE (beneficial)	SMALL (adverse) to LARGE (beneficial)	SMALL (adverse) to LARGE (beneficial)
Environmental Justice	Disproportionately high and adverse impacts are not expected.		
Air Quality	SMALL to MODERATE	SMALL	SMALL
Climate Change	SMALL	SMALL	SMALL
Geology and Soils	SMALL	SMALL	SMALL
Surface-Water Quality and Use	SMALL	SMALL	SMALL
Groundwater Quality and Use	SMALL	SMALL	SMALL
Terrestrial Resources	SMALL to MODERATE	SMALL	SMALL
Aquatic Ecology	SMALL	SMALL	SMALL
Special Status Species and Habitat	Impacts for Federally listed threatened and endangered species and Essential Fish Habitat would be determined as part of the consultations for the ESA and the Magnuson–Stevens Fishery Conservation and Management Act.		
Historic and Cultural Resources	SMALL to LARGE	SMALL to LARGE	SMALL to LARGE
Noise	SMALL	SMALL	SMALL
Aesthetics	SMALL to MODERATE	SMALL to MODERATE	SMALL to MODERATE
Waste Management			
Low-Level Waste	SMALL	SMALL	SMALL
Mixed Waste	SMALL	SMALL	SMALL
Nonradioactive Waste	SMALL	SMALL	SMALL to MODERATE
Transportation			
Traffic	SMALL to MODERATE	SMALL to MODERATE	SMALL to MODERATE
Health	SMALL	SMALL	SMALL
Public and Occupational Health	SMALL	SMALL	SMALL
Accidents	SMALL	SMALL	SMALL
Sabotage or Terrorism	SMALL	SMALL	SMALL

ES.17 Did the NRC Look at Cumulative Impacts?

Cumulative impacts result when the effects of an action are added to or interact with other effects in a particular place and within a particular time.

In Chapter 6, the NRC examined the incremental impact of continued storage on each resource area in combination with other past, present, and reasonably foreseeable actions. The introductory sections of Chapter 6 discuss the NRC's methodology for

assessing cumulative impacts, including the spatial and temporal bounds on which the NRC based its analyses, and provide a table that describes national, regional, and local trends that informed the NRC's consideration of reasonably foreseeable future actions. Trends that the NRC examined include increased energy demand, continued use of radiological materials, increased water demand, population growth and demographic shifts, increased urbanization, transportation, and other activities and environmental stressors. The spatial boundaries for the cumulative impact assessment are unique to each resource area and defined in resource-specific analyses in Section 6.4. Each geographic area of analysis includes the area surrounding a single continued storage site and extends to where the resource would be affected by continued storage and could have overlapping impacts with other past, present, and reasonably foreseeable future actions. The temporal boundary for the cumulative effects analysis includes activities that could occur through decommissioning of at-reactor or away-from-reactor storage facilities.

Table ES-5 provides a summary of the determinations made in Chapter 6. The second and third columns list resource impact determinations made in Chapters 4 and 5. These impacts are combined with the past, present, and reasonably foreseeable actions discussed in Chapter 6. The last column lists the cumulative impacts to resource areas. Discussions about impact differences resulting from cumulative effects can be found in Chapter 6.

Table ES-5. Summary of Cumulative Impacts for Continued Storage of Spent Fuel

Resource Area	Incremental Impact from At- Reactor Storage	Incremental Impact from Away-from- Reactor Storage	Cumulative Impact from Continued Storage and Other Federal and Non- Federal Activities
Land Use	SMALL	SMALL	SMALL to MODERATE
Socioeconomics	SMALL	SMALL (adverse) to LARGE (beneficial)	SMALL to LARGE
Environmental Justice	Disproportionately high and adverse impacts are not expected		
Air Quality	SMALL	SMALL to MODERATE	SMALL to MODERATE
Climate Change	SMALL	SMALL	MODERATE
Geology and Soils	SMALL	SMALL	SMALL to MODERATE
Surface-Water Quality and Use	SMALL	SMALL	SMALL to LARGE

Table ES-5. Summary of Cumulative Impacts for Continued Storage of Spent Fuel (cont'd)

Resource Area	Incremental Impact from At-Reactor Storage	Incremental Impact from Away-from-Reactor Storage	Cumulative Impact from Continued Storage and Other Federal and Non-Federal Activities
Groundwater Quality and Use	SMALL	SMALL	SMALL to LARGE
Terrestrial Resources ^(a)	SMALL	SMALL to MODERATE	SMALL to MODERATE
Aquatic Ecology ^(a)	SMALL	SMALL	SMALL to LARGE
Historic and Cultural Resources	SMALL to LARGE	SMALL to LARGE	SMALL to LARGE
Noise	SMALL	SMALL	SMALL to MODERATE
Aesthetics	SMALL	SMALL to MODERATE	SMALL to MODERATE
Waste Management	SMALL to MODERATE	SMALL to MODERATE	SMALL to LARGE
Transportation	SMALL	SMALL to MODERATE	SMALL to MODERATE
Public and Occupational Health	SMALL	SMALL	SMALL
Accidents	SMALL	SMALL	SMALL

(a) Cumulative impacts to Federally listed threatened and endangered species and Essential Fish Habitat would be determined as part of consultations for the ESA and the Magnuson–Stevens Fishery Conservation and Management Act.

ES.18 What is the Purpose of Chapter 8 of the GEIS?

Chapter 8 provides a summary of the environmental impacts and consequences of continued at-reactor and away-from-reactor storage. In addition, Chapter 8 addresses the following NEPA elements for use in future site-specific environmental reviews: (1) unavoidable adverse environmental impacts of continued storage; (2) irreversible and irretrievable resource commitments of continue storage; and (3) the relationship between short-term uses of the environment and the maintenance and enhancement of long-term productivity.

ES.18.1 What are the Unavoidable Adverse Impacts of Continued Storage?

Unavoidable adverse environmental impacts are those potential impacts of continued storage that cannot be avoided because of constraints inherent in using at-reactor and away-from-reactor spent fuel storage facilities for continued storage. The unavoidable adverse environmental impacts associated with continued storage would include impacts of (1) short-term storage in a spent fuel pool, as well as (2) short-term storage, (3) long-term storage, and (4) indefinite storage in at-reactor and away-from-reactor ISFSIs. These impacts are summarized in Table ES-3 and Table ES-4.

ES.18.2 What are the Irreversible and Irretrievable Resource Commitments of Continued Storage?

An irreversible resource commitment is a commitment of environmental resources—to a particular action—that cannot be restored. An irretrievable commitment of resources refers to a commitment of material resources that, once used, cannot be recycled or restored for other uses by practical means. Impacts on land use, terrestrial ecology, aquatic ecology, aesthetics, historic and cultural resources, and waste management would all result in irreversible commitments of resources. Replacement of ISFSI components and transportation would result in irretrievable commitments.

ES.18.3 What is the Relationship between Short-Term Uses of the Environment and the Maintenance and Enhancement of Long-Term Productivity?

The NRC recognizes the relationship between local short-term uses of the environment and the maintenance and enhancement of long-term productivity that occurs from continued storage, which may be authorized by future licensing actions. The local short-term use of the human environment is summarized in terms of the unavoidable adverse environmental impacts and irreversible and irretrievable commitments of resources. The long-term productivity period is the time period beyond continued storage.

Decisions regarding dismantlement and decommissioning affect this relationship. The maximum long-term impact on productivity would result when an at-reactor or away-from-reactor ISFSI is not immediately dismantled at the end of storage operations, or, as with the indefinite storage timeframe, it remains in operation indefinitely. Consequently, the land occupied by an ISFSI would not be available for any other uses. By contrast, when site decommissioning is complete, and an NRC license is terminated, a site would be available for other uses.

Other potential long-term impacts on productivity include the commitment of land and consumption of disposal capacity necessary to meet waste disposal needs. In addition, because loss of historic and cultural resources would constitute irreversible impacts, any loss of historic and cultural resources during continued storage would persist as long-term impacts. A small contribution to greenhouse gas emissions would add to the atmospheric burden of emissions that could contribute to potential long-term impacts.

ES.19 How did the NRC Address Spent Fuel Pool Fires and Leaks?

The NRC assessed the environmental impacts of spent fuel pool fires and leaks as part of the analysis in the GEIS. Appendix E describes the environmental impacts of spent fuel pool leaks during the short-term storage timeframe, and Appendix F describes the environmental impacts of a spent fuel pool fire during the short-term storage timeframe. In the GEIS, the NRC assumes that all spent fuel being stored in spent fuel pools will be transferred to dry casks by the end of the 60-year (short-term) storage timeframe.

ES.19.1 Spent Fuel Pool Leaks

A variety of factors work together to make it unlikely that a spent fuel pool leak would result in noticeable offsite environmental impacts during continued storage. These include the combination of spent fuel pool design and maintenance, operational and regulatory practices (e.g., leakage monitoring, NRC oversight, and groundwater monitoring), site hydrogeologic characteristics, and radionuclide transport properties.

Tritium is a radioactive isotope of hydrogen. Water containing tritium is normally released from nuclear power plants under controlled, monitored conditions that the NRC mandates to protect public health and safety. The NRC evaluates abnormal releases of tritium-contaminated water. More information about tritium from nuclear power plants can be found at <http://www.nrc.gov/reading-rm/doc-collections/fact-sheets/tritium-radiation-fs.html>.

For impacts to groundwater resources, though unlikely, it is possible that a leak of sufficient quantity and duration could occur, resulting in noticeable, but not destabilizing impacts to groundwater resources. The factors that could lead to a significant leak are many and varied. These factors include the magnitude and duration of the leak, the radiological constituents of the leak, the hydrologic conditions of the site, and the distance to the offsite groundwater resource. All these factors, in addition to the assessment of past leaks and the promulgation of regulations requiring subsurface surveys to determine the presence and extent of subsurface contamination, leads NRC to conclude that the environmental impacts of a spent fuel pool leak during continued storage would be SMALL.

Public health concerns would be related to groundwater contamination and would be limited to private wells nearest the site. In the event of uncontrolled and undetected discharges associated with long-term spent fuel pool leaks to nearby surface waters, the annual discharge would be comparable to normal discharges associated with operating reactors, and would likely remain below limits in 10 CFR Part 50, Appendix I. If, in the unlikely event that a pool leak remained undetected for a long period of time, public health regulatory limits (i.e., EPA drinking water standards) could potentially be exceeded, and the public health impacts could be noticeable, but not destabilizing. However, it is unlikely that a leak of sufficient quantity and

Executive Summary

duration could occur without detection, or that a leak would not be impeded by the inherent hydrologic characteristics typical at spent fuel pool locations. Therefore, based on the low probability that a long-duration leak exceeding effluent limits would go undetected and affect offsite groundwater sources to the extent that a public health limit would be exceeded, the NRC concludes that impacts during the short-term storage timeframe would be SMALL.

ES.19.2 Spent Fuel Pool Fires

The spent fuel pool fire environmental impacts described in Appendix F are based upon a summary of spent fuel pool fire risk studies the NRC has completed since 1975. While most of the earlier studies were concerned with spent fuel pool fire risk during the operating life of a reactor, the *Technical Study of Spent Fuel Pool Accident Risk at Decommissioning Nuclear Power Plants* (NUREG–1738), completed in 2001, examined the risk of spent fuel pool fires during the reactor decommissioning period, which is the same storage timeframe of continued storage of spent fuel on which this GEIS is focused. The GEIS assumes that all fuel will be removed from the spent fuel pool by the end of the 60-year decommissioning period, which corresponds to the end of the short-term timeframe.

The NRC's determination of SMALL for the environmental impacts of a spent fuel fire is based on a **probability-weighted consequence**. This means that the risk of a spent fuel fire informed the impact determination of SMALL.

The risk of a spent fuel fire is low because even though the consequences would be high, the probability is extremely low.

The conservative estimates used to assess spent fuel pool fire accidents, based on the NRC's previous analyses, result in probability-weighted population doses and economic consequences that are comparable to the values calculated for a severe reactor accident, as estimated in the 1996 and 2013 License Renewal GEIS. Furthermore, mitigation measures implemented by licensees as a result of NRC Orders and regulations have further lowered the risk of this class of accidents. As a result, the NRC finds that the environmental impacts from spent fuel pool fires are SMALL during the short-term timeframe.

ES.20 Does the GEIS Address Costs?

Chapter 7 of the GEIS analyzes and compares the benefits and costs associated with the proposed action (adopting a revised 10 CFR 51.23) and the NRC's options in the case of no action (site-specific review, GEIS-only, and policy statement). The no-action options do not alter the environmental impacts of continued storage that the NRC addresses in Chapters 4, 5, and 6. Instead, the options considered provide different administrative approaches that the NRC could apply to future licensing reviews to satisfy the agency's responsibility to consider the potential environmental impacts of continued storage in deciding whether to issue certain new and renewed licenses. Section 7.1 includes assumptions about financial costs and current and

future licensing reviews that are the bases for the cost analysis, while the NRC addresses unquantified costs and benefits throughout Chapter 7.

Section 7.6 summarizes and compares the estimated costs and benefits of the proposed action and the potential options in the case of no action. The cost for the proposed action (adopting a revised 10 CFR 51.23) is significantly lower than the cost for any of the no-action options. This occurs primarily because the NRC does not undertake site-specific reviews of the continued storage issue in the course of individual licensing proceedings as part of the proposed action. In general, the potential options in the case of no action are more costly than the proposed action.

The NRC provides cost information about continued storage facilities and activities in Chapter 2 in response to a large number of public comments on the draft GEIS that requested this information.

ES.21 What is the NRC's Recommendation?

Section 7.7 of the GEIS provides NRC's recommendation that the proposed action is the preferred alternative. The NRC recommendation is based on (1) the NRC's analysis of the cost-benefit balance of the proposed action and the options in the case of no action as presented in Chapter 7; (2) the NRC's consideration of public-scoping and draft GEIS comments in the development of the final GEIS; (3) the lack of environmental impacts associated with either the proposed action or the NRC's options in the case of no action; and (4) the determination that the environmental impacts of continued storage analyzed in the GEIS are unaffected by the NRC's choice of a particular administrative approach for considering the environmental impacts of continued storage in NRC licensing processes.

The NRC recommendation is to select the proposed action—adopting a revision to 10 CFR 51.23 that codifies the impact determinations from the GEIS—as the preferred alternative.

ES.22 How is the GEIS Related to the Rule?

This GEIS provides a regulatory basis for the NRC's revised Rule, 10 CFR 51.23. Appendix B of the GEIS contains detailed information about the previous Waste Confidence proceedings, and addresses two relevant topics from Waste Confidence proceedings: (1) the technical feasibility of continued safe storage and (2) repository availability. NRC's conclusions regarding these topics continue to undergird the agency's environmental analysis.

ES.23 Are There Any Areas of Controversy in the GEIS?

There were two areas of controversy raised in the Court of Appeals' remand of the 2010 Waste Confidence Rule. These areas of controversy are described below.

1. The NRC has included detailed analyses of spent fuel pool leaks and spent fuel pool fires. Historically, the NRC has devoted considerable attention to these topics, and there has been intense public interest in these issues, as evidenced by comments received during the litigation on the 2010 Waste Confidence update, during the scoping period, and during the comment period on the draft GEIS and proposed Rule. The NRC therefore prepared separate appendices to provide additional detail regarding the studies and analyses that underlie the analyses of spent fuel pool fires and leaks.
2. The NRC has included indefinite storage as one of the three timeframes analyzed in this GEIS. The NRC has devoted considerable attention to this timeframe in response to the intense public interest in this issue, as evidenced by comments received during the litigation on the 2010 Waste Confidence update, during the scoping period, and during the comment period on the draft GEIS and proposed Rule. Although the NRC believes it is likely that a repository will be available by 60 years after the end of a reactor's licensed life for operation, it recognizes that the availability of a repository is a controversial issue and has included an analysis of indefinite storage in the GEIS.

ES.24 Are There Any Remaining Issues to be Resolved?

For the purposes of successfully completing the GEIS while meeting NEPA requirements, the NRC believes there are numerous sources of the requisite technical data and information available; therefore, there are no remaining issues that require resolution. In the reference section of each chapter, the NRC has listed technical documents and reports on pertinent issues that are used to support the analyses in the GEIS. The NRC relied on accurate and high-quality information to ensure the GEIS contains a thorough and rigorous environmental impact analysis. The NRC will continue to review health and environmental effects of spent fuel storage as part of its ongoing licensing, oversight, and research activities. Any new information, such as the performance of spent fuel during lengthy periods of time, will be used to update and improve the NRC's regulatory requirements as appropriate.

ES.25 How Can I Obtain a Copy of the GEIS and Rule?

The final GEIS can be accessed online at <http://www.nrc.gov/reading-rm/doc-collections/nuregs/staff/> or in ADAMS under Accession No. ML14198A440. The draft GEIS can be accessed in ADAMS at ML13224A106. The final Rule will be published in the *Federal Register* and at www.regulations.gov.

Abbreviations/Acronyms

ACHP	Advisory Council on Historic Preservation
ADAMS	Agencywide Documents Access and Management System
AEA	Atomic Energy Act
AEC	U.S. Atomic Energy Commission
ALARA	as low as is reasonably achievable
ANDRA	French National Agency for Radioactive Waste Management
ANS	American Nuclear Society
ANSI	American National Standards Institute
APA	Administrative Procedure Act
APS	American Physical Society
ASLBP	Atomic Safety and Licensing Board Panel
ASME	American Society of Mechanical Engineers
ATRI	American Transportation Research Institute
B	billion
BEIR	biological effects of ionizing radiation
BLS	Bureau of Labor Statistics
BMP	best management practice
BWR	boiling water reactor
CEDE	committed effective dose equivalent
CEQ	Council on Environmental Quality
CFR	<i>Code of Federal Regulations</i>
CNWRA	Center for Nuclear Waste Regulatory Analyses
CO ₂	carbon dioxide
CoC	certificate of compliance
COL	combined license
CPB	U.S. Customs and Border Protection
CPI	Consumer Price Index
D.C.	District of Columbia
dBA	decibel(s) (acoustic)
DBT	design basis threat
DBTT	ductile-to-brittle transition temperature

Abbreviations/Acronyms

DEC	Department of Environmental Conservation
DOE	U.S. Department of Energy
DOT	U.S. Department of Transportation
DTS	dry transfer system
EA	Environmental Assessment
EFH	essential fish habitat
EIS	environmental impact statement
EMF	electromagnetic field
EPA	U.S. Environmental Protection Agency
EPRI	Electric Power Research Institute
ESA	Endangered Species Act of 1973, as amended
ESP	early site permit
FEIS	final environmental impact statement
FONSI	finding of no significant impact
FR	<i>Federal Register</i>
FSAR	Final Safety Analysis Report
FTE	full-time equivalent
FWS	U.S. Fish and Wildlife Service
GAO	Government Accountability Office
GCRP	U.S. Global Change Research Program
GEH	General Electric-Hitachi
GEIS	Generic Environmental Impact Statement
GHG	greenhouse gases
GTCC	greater than class C
HLW	high-level waste
HOSS	hardened onsite storage
HSM	horizontal storage modules
IAEA	International Atomic Energy Agency
INL	Idaho National Laboratory
iPWR	integral pressurized water reactor
ISFSI	independent spent fuel storage installation
LLW	low-level waste
LWR	light water reactor

Abbreviations/Acronyms

M	million
MACCS	MELCOR Accident Consequence Code System
MCL	maximum contaminant level
MEI	maximally exposed individual
MOX	mixed oxide
MTU	metric tons of uranium
NA	not applicable
NAAQS	National Ambient Air Quality Standards
NAS	National Academy of Sciences
NEI	Nuclear Energy Institute
NEPA	National Environmental Policy Act of 1969, as amended
NHPA	National Historic Preservation Act of 1966, as amended
NMFS	National Marine Fisheries Services
NMSS	Office of Nuclear Material Safety and Safeguards
NPDES	National Pollutant Discharge Elimination System
NRC	U.S. Nuclear Regulatory Commission
NRDC	Natural Resources Defense Council
NRHP	National Register of Historic Places
NWPA	Nuclear Waste Policy Act
OMB	Office of Management and Budget
OSHA	Occupational Safety and Health Administration
PAG	protective action guide
PFS	Private Fuel Storage, LLC
PFSF	Private Fuel Storage Facility
PM	particulate matter
PM ₁₀	particulate matter with a diameter of 10 microns or less
PM _{2.5}	particulate matter with a diameter of 2.5 microns or less
PRA	probabilistic risk assessment
PWR	pressurized water reactors
QA	quality assurance
RCRA	Resource Conservation and Recovery Act of 1976, as amended
REMP	radiological environmental monitoring program

Abbreviations/Acronyms

SAMA	severe accident mitigation alternatives
SKB	Swedish Nuclear Fuel and Waste Management Company
SMR	small modular reactor
SOC	Statement of Considerations
TEDE	total effective dose equivalent
TMI-2	Three Mile Island Unit 2
TN	Transnuclear Inc.
TRU	transuranic (waste)
TVA	Tennessee Valley Authority
USACE	U.S. Army Corps of Engineers
USC	United States Code
USCB	U.S. Census Bureau
WIPP	Waste Isolation Pilot Plant

Units of Measure

Metric Prefixes

tera (T-)	10 ¹²
giga (G-)	10 ⁹
mega (M-)	10 ⁶
kilo (k-)	10 ³
hecto (h-)	10 ²
deci (d-)	10 ⁻¹
centi (c-)	10 ⁻²
milli (m-)	10 ⁻³
mirco (μ-)	10 ⁻⁶
nano (n-)	10 ⁻⁹
pico (p-)	10 ⁻¹²

Radiological Units

μCi/ml	microcurie(s) per milliliter
Bq	becquerel(s)
Ci	curie(s)
Ci/L	curies per liter
Ci/yr	curie(s) per year
mrem	millirem
mSv	millisievert(s)
pCi	picocurie(s)
pCi/L	picocurie(s) per liter
R	roentgen
rad	special unit of absorbed dose
rem	roentgen equivalent man (a special unit of radiation dose)
S	siemens
Sv	sievert

Length/Distance

cm	centimeter(s)
ft	foot or feet
in.	inch(es)
km	kilometer(s)
m	meter(s)
mi	mile(s)
mm	millimeter(s)
yd	yard(s)

Volume

m ³	cubic meter(s)
yd ³	cubic yard(s)
ft ³	cubic foot(feet)
L	liter(s)
gal	gallon(s)
gpd	gallon(s) per day
gpm	gallon(s) per minute
oz	ounce(s)

Area

ha	hectare(s)
ac	acre(s)
ft ²	square foot(feet)
mi ²	square mile(s)
m ²	square meter(s)

Units of Time

hr	hour(s)
mo	month
s	second(s)
yr	year(s)
min	minute
Ryr	reactor year(s)

Units of Measure

Units of Temperature

°C	degree(s) Celsius
°F	degree(s) Fahrenheit

Units of Concentration

ppm	parts per million
ppt	parts per thousand

Units of Speed

mph	mile(s) per hour
-----	------------------

Units of Weight

MT	metric ton(s) (or tonne[s])
MTU	metric ton(s) of uranium
T	ton(s)

Units of Power

Btu	British thermal unit(s)
GWd	gigawatt-day(s)
MW	megawatt(s)
MW(e)	megawatt(s) electrical
Ci/L	curies per liter
L/d	liter(s) per day
L/min	liter(s) per minute
ml or mL	milliliter(s)

1.0 Introduction

Since the inception of commercial nuclear power, the United States has worked to find a disposal solution for spent nuclear fuel (spent fuel) generated by commercial nuclear power reactors. In the late 1970s, the U.S. Nuclear Regulatory Commission (NRC) reexamined an underlying assumption used in licensing reactors to that time—that a repository could be secured for the ultimate disposal of spent fuel generated by nuclear reactors, and that spent fuel could be safely stored in the interim. This analysis was called the Waste Confidence proceeding.

This *Generic Environmental Impact Statement for Continued Storage of Spent Nuclear Fuel* (GEIS) addresses the environmental impacts of continuing to store spent fuel at a reactor site or at an away-from-reactor storage facility, after the end of the licensed life for operations of a reactor¹ until final disposition in a geologic repository (“continued storage”), historically addressed as part of the NRC’s waste confidence proceeding. This GEIS has been prepared to fulfill the Commission’s obligations under the National Environmental Policy Act of 1969, as amended (NEPA) and NRC regulations implementing NEPA in Title 10 of the *Code of Federal Regulations* (CFR) Part 51.

1.1 History of Waste Confidence

The first Waste Confidence rulemaking began in the late 1970s in response to two significant legal proceedings. In 1977, the Commission denied a petition for rulemaking filed by the Natural Resources Defense Council (NRDC) that asked the NRC to determine whether radioactive wastes generated in nuclear power reactors can be disposed of without undue risk to public health and safety and to refrain from granting pending or future requests for reactor operating licenses until the NRC made a determination regarding disposal. The Commission stated in its denial that, as a matter of policy, it “... would not continue to license reactors if it did not have reasonable confidence that the wastes can and will in due course be disposed of safely” (42 FR 34391). The Commission’s denial of the NRDC petition was affirmed upon judicial review (*NRDC v. NRC*). Since that time, the Federal government has adopted deep geologic disposal as the national solution for spent fuel disposal (Nuclear Waste Policy Act of 1982). Recently, the U.S. Department of Energy (DOE) reaffirmed the Federal government’s commitment to the ultimate disposal of spent fuel and predicted that a repository would be available by 2048 (DOE 2013).

¹ As used in the GEIS, the term “licensed life for operation” of a reactor is the period running to the end of the operating license term for a reactor, which may include the term of a revised or renewed license.

Introduction

At about the same time the Commission denied the NRDC petition, the State of Minnesota and the New England Coalition on Nuclear Pollution challenged license amendments that permitted expansion of the capacity of spent fuel storage pools at two nuclear power plants, Vermont Yankee and Prairie Island. In 1979, the Court of Appeals for the District of Columbia (D.C.) Circuit, in *Minnesota v. NRC*, remanded to the Commission the question of whether an offsite storage or disposal solution would be available for the spent fuel at the two facilities at the expiration of their licenses—at that time scheduled for 2007 and 2009—and, if not, whether the spent fuel could be stored safely at those reactor sites until an offsite solution was available.

In 1979, the NRC initiated a generic rulemaking that stemmed from these challenges and the Court of Appeals' remand in *Minnesota v. NRC*. The Waste Confidence rulemaking generically assessed whether the Commission could have reasonable assurance that spent fuel produced by nuclear power plants "...can be safely disposed of...when such disposal or offsite storage will be available, and...whether radioactive wastes can be safely stored onsite past the expiration of existing facility licenses until offsite disposal or storage is available" (44 FR 61372). On August 31, 1984, the Commission published the Waste Confidence decision (49 FR 34658) (Decision) and a final Rule (49 FR 34688), which codified elements of the decision at 10 CFR 51.23 (Rule) and adopted revisions to 10 CFR Part 50 that established procedures to "...confirm that there will be adequate lead time for whatever actions may be needed at individual reactor sites to assure that the management of spent fuel following the expiration of the reactor operating license will be accomplished in a safe and environmentally acceptable manner" (49 FR 34689). In addition to addressing the NRC's assessment of the issues presented by the Court of Appeals' remand, the Decision provided an environmental assessment (EA) and finding of no significant impact (FONSI) to support the Rule (NRC 1989).

The analysis in 10 CFR 51.23 found that, for at least 30 years beyond the expiration of a reactor's licensed life for operations, no significant environmental impacts would result from storage of spent fuel, and expressed the Commission's reasonable assurance that a repository was likely to be available in the 2007 to 2009 timeframe. The Rule also stated that, as a result of this generic determination, the NRC need not prepare any site-specific environmental analysis in connection with continuing storage when issuing a license or amended license for a new reactor or independent spent fuel storage facility (ISFSI) (10 CFR 51.23(b)).

The first review of the Decision and the Rule occurred in 1989 and 1990. This review resulted in revisions to the Decision and the Rule to reflect revised expectations for the availability of the first repository, and to clarify that the expiration of a reactor's licensed life for operations referred to the full 40-year initial license for operations and a 30-year revised or renewed license. On September 18, 1990, the Commission published the revised Decision (55 FR 38474) and final Rule (55 FR 38472).

The Commission conducted its second review of the Decision and the Rule in 1999 and concluded that experience and developments after 1990 had confirmed the findings and made a comprehensive reevaluation of the Decision and Rule unnecessary. The Commission also stated that it would consider undertaking a comprehensive reevaluation when the pending repository development and regulatory activities had run their course or if significant and pertinent unexpected events occurred that raised substantial doubt about the continuing validity of the Waste Confidence decision (64 FR 68005).

In 2008, the Commission decided to conduct its third review of the Decision and the Rule. This review resulted in revisions to reflect revised expectations for the availability of the first repository and to encompass at least 60 years of continued storage. In December 2010, the Commission published its revised Decision (75 FR 81032) and final Rule (75 FR 81037).

In response to the 2010 rulemaking, the States of New York, New Jersey, Connecticut, and Vermont; several public interest groups; and the Prairie Island Indian Community sought review in the Court of Appeals challenging the Commission's NEPA analysis that supported the Rule. On June 8, 2012, the Court of Appeals ruled that some aspects of the 2010 Waste Confidence rulemaking did not satisfy the NRC's NEPA obligations. The Court of Appeals therefore vacated the Decision and the Rule and remanded the case to the NRC for further proceedings consistent with the Decision (*New York v. NRC*).

The Court of Appeals concluded that the Waste Confidence rulemaking proceeding is a major Federal action necessitating either an environmental impact statement (EIS) or an EA that results in a FONSI. The Court of Appeals identified three deficiencies in the NRC's environmental analysis:

1. Related to the Commission's conclusion that permanent disposal will be available "when necessary," the Court of Appeals held that the Commission needed to evaluate the environmental effects of failing to secure permanent disposal, given the uncertainty about whether a repository would be built.
2. Related to 60 years of continued storage, the Court of Appeals concluded that the Commission had not adequately examined the risk of spent fuel pool leaks in a forward-looking fashion.
3. Also related to continued storage, the Court of Appeals concluded that the Commission had not adequately examined the consequences of potential spent fuel pool fires.

In response to the Court of Appeals' decision, the Commission stated in Commission Order CLI-12-16 that it would not issue reactor or ISFSI licenses dependent upon the Waste Confidence Rule until the Court of Appeals' remand is appropriately addressed (NRC 2012a). This decision is not an indication that the Commission lacks confidence in the availability of an ultimate disposal solution, but rather reflects the Commission's need to develop an analysis that

Introduction

assesses the environmental impacts of continued storage in a manner addressing the Court of Appeals' remand.² The Commission stated, however, that this determination extends only to issuance of the reactor or ISFSI license, and that all licensing reviews and proceedings should continue to move forward. In SRM–COMSECY–12–0016, the Commission directed the NRC to develop a GEIS to support an updated Waste Confidence decision and rule (NRC 2012b).

1.2 Scope of the Generic Environmental Impact Statement

This GEIS analyzes the environmental impacts of continued storage and provides a regulatory basis for the revision to the NRC's Waste Confidence Rule.

The Waste Confidence Rule, originally adopted by the Commission in 1984, satisfies part of the Commission's NEPA obligation to prepare an environmental analysis in the course of a licensing proceeding for a commercial nuclear power reactor or a facility that will store the spent fuel generated by these reactors.

For both power reactor and storage facilities, NEPA requires that the NRC address direct, indirect, and cumulative impacts of its licensing actions. Thus, in issuing a power reactor license, the NRC must analyze the environmental impacts resulting from the generation of spent fuel by the reactor and its continued storage pending ultimate disposal. Likewise, for an ISFSI, the NRC must analyze the impacts of continued storage at the facility until ultimate disposal for the spent fuel is available. The environmental impacts addressed in this GEIS are limited to the environmental impacts of continued storage.

This GEIS considers three possible continued storage timeframes: (1) short-term storage of no more than 60 years after the end of a reactor's licensed life for operations; (2) long-term storage of no more than 160 years after the end of a reactor's licensed life for operations; and (3) indefinite storage at a reactor site or at an away-from-reactor ISFSI. The indefinite storage scenario assumes that disposal in a repository never becomes available.

As discussed above, the NRC has analyzed three timeframes that represent various scenarios for the length of continued storage that will be needed before spent fuel is sent to a repository. The first, most likely, timeframe is the short-term timeframe, which analyzes 60 years of continued storage after the end of a reactor's licensed life for operations. As discussed in more detail later in this GEIS and in Appendix B to this GEIS, the NRC believes this is the most likely

² "Waste confidence undergirds certain agency licensing decisions, in particular new reactor licensing and reactor license renewal. Because of the recent court ruling striking down our current waste confidence provisions, we are now considering all available options for resolving the waste confidence issue, which could include generic or site-specific NRC actions, or some combination of both. We have not yet determined a course of action. But, in recognition of our duties under the law, we will not issue licenses dependent upon the Waste Confidence Decision or the Temporary Storage Rule until the court's remand is appropriately addressed." (NRC 2012a) at 4 *citations omitted*.

timeframe because the DOE has expressed its intention to provide repository capacity by 2048, which is about 10 years before the end of this timeframe for the oldest spent fuel within the scope of this analysis. Further, international and domestic experience with deep geologic repository programs supports a timeline of 25 to 35 years to provide repository capacity for the disposal of spent fuel. The DOE's prediction of 2048 is in line with this expectation. The NRC acknowledges, however, that the short-term timeframe, although the most likely, is not certain. Accordingly, two additional timeframes also are analyzed in this GEIS. The long-term timeframe considers the environmental impacts of continued storage for a total of 160 years after the end of a reactor's licensed life for operations. Finally, although the NRC considers it highly unlikely, this GEIS includes an analysis of an indefinite timeframe, which assumes that a repository does not become available.

1.3 Purpose of the Generic Environmental Impact Statement

The purpose of the GEIS is twofold:

1. To determine the environmental impacts of continued storage, including those impacts identified in the remand by the Court of Appeals in the *New York v. NRC* decision
2. To determine whether those impacts can be generically analyzed.

In the draft GEIS, the NRC preliminarily identified the environmental impacts of continued storage and determined that they could be addressed generically. In the process of developing this final GEIS, including considering and responding to the substantial volume of public comments the NRC received in response to the draft GEIS and proposed Rule, the NRC has confirmed that the impacts of continued storage can be generically addressed. Therefore, the GEIS provides a regulatory basis for a revision to 10 CFR 51.23 that addresses the environmental impacts of continued storage for use in future NRC environmental reviews.

1.4 Proposed Federal Action

The Federal action is the adoption of a revised Rule, 10 CFR 51.23, which codifies (i.e., adopts into regulation) the analysis in the GEIS of the environmental impacts of continued storage of spent fuel.

Having confirmed that the environmental impacts of continued storage can be analyzed generically, the Commission has decided to codify the GEIS impact determinations in a revised rule, 10 CFR 51.23. The rule states that, because the impacts of continued storage have been generically assessed in this GEIS, NEPA analyses for relevant future reactor and spent fuel storage facility licensing actions will not need to separately consider the environmental impacts of continued storage.

As codified, the impact determinations in the GEIS will inform the decisionmakers in licensing proceedings of the reasonably foreseeable environmental impacts of continued storage. These determinations will be weighed along with other impacts determined by the NRC on a site-specific basis for a facility or an activity. Thus, in the course of an individual licensing proceeding, the decisionmaker will be able to compare all the environmental impacts of a proposed licensing action (e.g., licensing a nuclear power reactor), including continued storage impacts, to the environmental impacts of reasonable alternatives, including the no-action alternative.

1.5 Purpose of and Need for the Proposed Action

The need for the proposed action is to provide processes for use in NRC licensing to address the environmental impacts of continued storage. Historically, the NRC and license applicants have relied on 10 CFR 51.23 to conclusively address the environmental impacts of continued storage in environmental reports, EISs, EAs, and hearings.

The purpose of the proposed action is to preserve the efficiency of the NRC's licensing processes with respect to the environmental impacts of continued storage.

1.6 Alternatives

The NRC has historically addressed its NEPA obligations for continued storage by means of an EA and a FONSI, adopted in 10 CFR 51.23. Thus, if the NRC chooses not to address the environmental impacts of continued storage by rule, the Commission would have to choose a different process to meet its NEPA obligations.

The Commission considered other options and approaches (called tracks) when it responded to COMSECY-12-0016 (NRC 2012c), in which the NRC was determining how to respond to the remand of *New York v. NRC*. If the NRC had determined during the course of the rulemaking process that the proposed revision to 10 CFR 51.23 was untenable or undesirable, then the Commission would have reconsidered whether to pursue the options and tracks in COMSECY-12-0016 (NRC 2012b), elements of which are incorporated in Section 1.6.1. Because none of the potential options the NRC could pursue if it did not continue with the rulemaking meets the purpose for the Federal action (i.e., they do not preserve the efficiency of the NRC's licensing processes), they will be addressed as options under the no-action alternative.

1.6.1 No-Action Alternative

The no-action alternative would be for the NRC not to issue the revision of 10 CFR 51.23 as a final rule (i.e., not to codify the impact determinations from this GEIS).

The prior version of 10 CFR 51.23 was vacated by the Court of Appeals in *New York v. NRC*. Therefore, adopting the no-action alternative would require the NRC to select a different approach for addressing the environmental impacts of continued storage in its licensing proceedings. The NRC could pursue a variety of options in the case of no action, including the following approaches.

- First, the NRC could review the environmental impacts from continued storage on a site-specific basis, rather than on a generic basis, in nuclear power plant and ISFSI licensing proceedings.
- Second, the NRC could finalize the GEIS without incorporating the results into a rule. This approach would allow the NRC to adopt these GEIS findings into environmental reviews for future licensing activities, but without the binding effect of a rule.
- Third, the Commission could issue a policy statement explaining how the Commission intends to address the NRC's NEPA obligations with respect to continued storage. The policy statement would not bind licensees and applicants like a rule, but it would provide notice of how, or whether, the Commission intends to incorporate the findings of the GEIS into environmental reviews for future licensing activities.

1.6.1.1 Site-Specific Review Option

If the NRC decided not to incorporate the results of this GEIS into a revision of 10 CFR 51.23, the NRC could address the environmental impacts of continued storage in site-specific reviews. These reviews would generally take place within the context of existing environmental review processes for new reactor licensing, reactor license renewal, and ISFSI licensing and renewals. In some cases, these reviews could involve time- and resource-intensive considerations of issues that could readily be resolved on a generic basis. Therefore, this option is inconsistent with Council on Environmental Quality guidance for achieving efficiency and timeliness under NEPA.

In the site-specific review option, it is likely that the NRC would incorporate as much of the analysis from this GEIS as possible into site-specific NEPA reviews. Later reviews would likely incorporate, by reference, applicable findings from the first few published environmental documents that used the analyses.

From a procedural perspective, the main effect of the site-specific review option is that the NRC would have to address the environmental impacts of continued storage for individual licensing proceedings on a site-by-site basis. Requiring the NRC to prepare site-specific discussions of generic issues, like those associated with continued storage, would result in the considerable expenditure of public, NRC, and applicant resources. Further, licensing boards could be required to hear nearly identical issues in each proceeding on these generic matters. Adopting the generic impacts of continued storage in a rule, on the other hand, allows the NRC and the participants in its licensing proceedings to focus their limited resources on site-specific issues that are unique to each licensing action.

1.6.1.2 GEIS-Only Option

If the NRC decided not to incorporate the results of this GEIS into a revision of 10 CFR 51.23, the NRC could issue this GEIS for use in support of site-specific licensing reviews. This nonbinding, GEIS-only option would add somewhat to the efficiency of NRC reviews by addressing issues that are similar at all sites or that otherwise are susceptible to generic consideration. For particular licensing actions, the EIS or EA could incorporate by reference any finding or conclusion of the GEIS, but participants in a proceeding could still raise issues regarding continued storage.

This approach would be consistent with Council on Environmental Quality guidance regarding efficiency and timeliness under NEPA. However, while this approach would be beneficial in terms of improved efficiency, the GEIS's findings and conclusions would remain open to challenge in site-specific reviews for reactor and ISFSI licensing proceedings. Although this incorporation-by-reference approach would satisfy NRC's NEPA obligations, this option could enable participants in contested licensing proceedings to raise issues that challenge the conclusions of the GEIS, an outcome that may result in considerable expenditure of public, NRC, and applicant resources. Further, licensing boards might be required to hear nearly identical contentions in individual licensing proceedings. Thus, although the "GEIS-only" approach would likely provide greater efficiencies than the site-specific review option, it would eliminate some of the efficiency and time-savings that the NRC would gain through a binding generic analysis of continued storage. Adopting the generic impacts of continued storage in a rule, on the other hand, would allow the NRC and parties to its licensing proceedings to focus their limited resources on the site-specific issues that are unique to each licensing action.

1.6.1.3 Policy-Statement Option

Instead of issuing a rule to adopt the results of the GEIS, the Commission could issue a policy statement that expresses its intent to either incorporate the environmental impacts determined by the GEIS into site-specific NEPA analyses or prepare a site-specific evaluation without regard to the GEIS for each NRC licensing action.

In general, a policy statement suffers from many of the same shortcomings as the site-specific review and GEIS-only no-action options. The NRC would still need to address the impacts of continued storage in site-specific NEPA analyses either by incorporating the impacts from the GEIS or through the consideration of the impacts on a site-specific basis if no GEIS is adopted. Like the site-specific review and GEIS-only no-action options, the policy-statement no-action option would reduce the efficiencies that the NRC would gain through a rule in which incorporation of environmental impacts of continued storage would be binding in licensing proceedings, although it would at least provide notice to participants that the Commission might elect to incorporate by reference all or a portion of the existing GEIS.

Preparation of site-specific analyses of continuing storage impacts would result in considerable expenditure of public, NRC, and applicant resources. Further, licensing boards could be expected to hear nearly identical issues in each proceeding on these generic matters. Conversely, determining and adopting the generic impacts of continued storage would allow the NRC and participants in its licensing proceedings to focus their limited resources on site-specific issues that are unique to each licensing action.

1.6.2 Alternatives Considered but Eliminated

Interested parties submitted numerous scoping comments suggesting that this GEIS should consider other actions as alternatives to adopting the proposed revision to 10 CFR 51.23. In this section, this GEIS considers and eliminates the most commonly suggested alternatives because they fail to meet the purpose and need for this proposed action.

1.6.2.1 Cessation of Licensing or Cessation of Reactor Operation

Cessation of licensing activities and cessation of reactor operations do not satisfy the stated purpose and need for this proposed action. Abandonment of reactor licensing and the closure of existing plants is not a reasonable alternative to the proposed action because these actions would not meet the NRC's stated objectives in proposing to adopt the revision to 10 CFR 51.23.

Through the Atomic Energy Act of 1954, as amended and the Energy Reorganization Act of 1974, as amended, Congress directed the NRC to issue licenses for nuclear power plants and certain nuclear materials if there is, among other things, no undue risk (i.e., that there is reasonable assurance of adequate protection) to public health and safety and common defense and security. In these statutes, Congress also authorized and directed the NRC to issue regulations establishing requirements for providing adequate protection to public health and safety and common defense and security (see Atomic Energy Act 161b). In separate rulemaking actions, the Commission established criteria through which the NRC (1) satisfies its Atomic Energy Act responsibility to ensure reasonable assurance of adequate protection of public health and safety in the construction and operation of nuclear power plants; and (2) satisfies its NEPA responsibility to consider environmental impacts in the construction and operation of nuclear power plants. Therefore, under current law the NRC will issue a nuclear power plant or materials license (including a license authorizing storage of spent fuel) when the NRC determines that a license applicant has met the NRC's regulatory standards for issuance of a license, addressing adequate protection of public health and safety and common defense and security, and the NRC has no reason to doubt that issuance of the license would provide adequate protection. Further, if the NRC determines that a nuclear power plant or the use of nuclear materials poses a threat to public health and safety or the common defense and security, the NRC will amend, suspend, or revoke nuclear power plant or materials licenses.

Introduction

Although cessation of nuclear power plant licensing and operations would halt the future generation of spent fuel, other environmental impacts could result from the required development of replacement power sources or demand reductions. Even then, the environmental impacts of continued storage would not cease until sufficient repository capacity becomes available.

1.6.2.2 Implementing Additional Regulatory Requirements

Imposing new regulatory requirements, such as requiring licensees to implement hardened at-reactor storage systems, reduce the density of spent fuel in pools, or expedite transfer of spent fuel from pools to ISFSIs, is outside the scope of this proposed action, which includes actions that preserve the efficiency of the NRC's licensing processes with respect to the environmental impacts of continued storage. Adoption of a revised 10 CFR 51.23, supported by this GEIS, is not a licensing action, and does not impose new requirements on licensees or applicants. Therefore, the NRC cannot impose new requirements or regulations on the duration of spent fuel storage in pools through this proposed action. In separate proceedings, the NRC is considering an update to its ISFSI security requirements, as described in the December 16, 2009, *Federal Register* Notice (74 FR 66589), "Draft Technical Basis for Rulemaking Revising Security Requirements for Facilities Storing SNF [spent nuclear fuel] and HLW [high-level waste]; Notice of Availability and Solicitation of Public Comments." The NRC has provided responses to public comments on this draft technical basis (NRC 2013a). In the context of the rulemaking, the NRC is also considering a petition requesting that the NRC require hardened onsite storage at all power plants and away-from-reactor storage sites (see "Petition for Rulemaking Submitted by C-10 Research and Education Foundation, Inc.," 77 FR 63254, October 16, 2012). The proposed rule, scheduled to be published for comment in 2017, will formally address the 2012 petition. In addition, the NRC has separately considered expedited transfer of spent fuel from pools into casks as part of lessons learned from the March 11, 2011, earthquake and subsequent tsunami that badly damaged the Fukushima I Nuclear Power Plant in Japan (NRC 2014a, 2013b, 2012d), and it will not be separately reconsidered in this proceeding.

1.6.3 Comparison of Reasonable Alternatives

The reasonable alternatives considered here include the proposed action (revising 10 CFR 51.23) and no action, which may result in the NRC pursuing any of several options: site-specific reviews of the environmental impacts of continued storage in each licensing proceeding, a generic EIS without a rule, or a Commission policy statement.

The proposed action and the NRC's potential options in case of no action are simply different administrative approaches for addressing the environmental impacts of continued storage

in NRC licensing processes. Consistent with the NRC's categorical exclusion³ in 10 CFR 51.22(c)(3)(i), the proposed action has no significant environmental impacts. The no-action alternative—including all of NRC's potential options in the case of no action—also has no significant environmental impacts. Therefore, the proposed action and the no-action alternative, including NRC's potential options in case of no action, have the same environmental impacts. In subsequent chapters of this GEIS, the NRC considers the potential environmental impacts that result from continued storage. In Chapter 7, the NRC provides a cost-benefit analysis of the proposed action and the no-action alternative, including NRC's potential options in case of no action.

1.7 Public and Agency Involvement

1.7.1 Scoping Process

The NRC began the environmental review process by publishing a Notice of Intent to prepare an EIS and conduct scoping in the *Federal Register* on October 25, 2012 (77 FR 65137). The NRC conducted live and webcast public meetings on November 14, 2012 (NRC 2012e), and conducted public webinars on December 5 and 6, 2012 (NRC 2012f). The NRC transcribed the discussions that took place during the scoping meetings and webinars. The NRC received approximately 700 pieces of comment correspondence, primarily through the website at www.regulations.gov (using Docket ID NRC–2012–0246) and, to a lesser extent, by fax and mail. The scoping period formally closed on January 2, 2013, although staff considered comments received after this date to the extent practical.

Scoping participants included private citizens and representatives of Tribes and State governments, the U.S. Environmental Protection Agency (EPA), multiple environmental and advocacy groups, industry, and quasi-governmental organizations. In all, the NRC identified approximately 1,700 comments from the materials submitted.

The NRC responded to comments in its *Waste Confidence Generic Environmental Impact Statement Scoping Process Summary Report* (NRC 2013c), which was published on March 4, 2013. The summary report, in accordance with 10 CFR 51.29(b), contained a summary of conclusions reached by the NRC and issues identified as a result of the scoping process. Additional information regarding the summary report is provided in Appendix A. A summary of outreach and correspondence related to the environmental review is provided in Appendix C.

³ A categorical exclusion refers to "... a category of actions which do not individually or cumulatively have a significant effect on the human environment and which the Commission has found to have no such effect in accordance with procedures set out in 51.22, and for which, therefore, neither an environmental assessment nor an environmental impact statement is required" (10 CFR 51.14).

1.7.2 Public Comments Received on the Draft GEIS and Proposed Rule

The EPA published a Notice of Availability in the *Federal Register* on September 13, 2013 (78 FR 56695), which started the 75-day public comment period on the draft GEIS. Due to the October 2013 government shutdown that caused the agency to reschedule several public meetings, the NRC extended the public comment period to December 20, 2013, for a total of 98 days (78 FR 66858). During the public comment period, the NRC hosted 13 public meetings throughout the United States to describe the results of the NRC’s environmental review, answer questions, and accept comments on the draft GEIS and proposed Rule. Approximately 1,400 participants at those meetings provided nearly 500 oral comments. In addition, the NRC received over 33,000 written submittals. Summaries of the public comments received on the draft GEIS and proposed Rule and the NRC’s responses are provided in Appendix D. Separately, the NRC published a document containing the text of all identified unique comments, *Comments on the Waste Confidence Draft Generic Environmental Impact Statement and Proposed Rule* (NRC 2014b).

This final GEIS—with the exception of Chapters 10 and 11 and Appendices D and I—uses “change bars,” indicated by vertical lines in the page margins, to denote where information has been revised in response to public comments, or where changes, other than minor editorial changes, have been made.

1.7.3 Cooperating Agencies

The NRC did not identify any cooperating agencies for the environmental review, nor did the NRC receive any formal requests for cooperating agency status.

1.8 Analytical Approach

The NRC’s methodology and approach to evaluating the environmental impacts of continued storage follows the guidance in NUREG–1748, *Environmental Review Guidance for Licensing Actions Associated with NMSS Programs: Final Report* (NRC 2003), where applicable.

This GEIS evaluates the potential environmental impacts of continued storage after the licensed life for reactor operations at reactor sites in Chapter 4, and at away-from-reactor sites in Chapter 5. The environmental impacts are evaluated for three timeframes based on when a repository would become available. This section outlines the approach, timeframes, assumptions, and previous NEPA assessments the NRC used in its evaluation.

1.8.1 Approach to Impact Assessment

To evaluate the potential environmental impacts of continued storage at reactor sites (Chapter 4), the NRC assumes that spent fuel is stored in a pool and in an ISFSI, both of which

have already been constructed and are operating during reactor operations. Therefore, many of the impacts of at-reactor continued spent fuel storage can be determined by comparing onsite activities that occur during reactor operations to the reduced activities that occur during continued storage. Where appropriate, the environmental impacts during reactor operations are drawn from the License Renewal GEIS (NRC 2013d), which evaluates the impacts of continued reactor operation. In addition, this GEIS uses analyses in EAs prepared for ISFSIs and renewals of those ISFSI licenses.

For the impacts of continued storage at an-away-from-reactor ISFSI (Chapter 5), the NRC evaluated the impacts of an ISFSI of the same size as described in the *Final Environmental Impact Statement for the Construction and Operation of an Independent Spent Nuclear Fuel Storage Installation on the Reservation of the Skull Valley Band of Goshute Indians and Related Transportation Facility in Tooele County, Utah* (NRC 2001). Chapter 5 contains a list of the assumptions used in that analysis. Unlike in Chapter 4, the generic analysis for away-from-reactor storage at an ISFSI includes a general discussion of the construction of the facility. However, the site-specific impacts of the construction and operation of any proposed away-from-reactor ISFSI would be evaluated by NRC as part of that ISFSI's licensing process.

For both the at-reactor and away-from-reactor storage sites, the NRC assumes that the construction, operation, and replacement of a dry transfer system (DTS) facility is necessary at some point to handle the transfer of fuel. The physical characteristics of a DTS, which is based on well-understood technology, are explained in more detail in Chapter 2 (see Section 2.1.4).

The GEIS accounts for the age of storage facilities in the evaluation of impacts. For example, a storage cask that was loaded with spent fuel 40 years prior to the end of the licensed life for reactor operations has already been in service for 40 years at the beginning of the short-term timeframe and is assumed to be replaced at the beginning of the long-term timeframe (40 years of service at the beginning of the short-term timeframe plus 60 years of service over the short-term timeframe results in a total service time of 100 years, which is the assumed replacement period for dry cask storage facilities).

1.8.2 Timeframes Evaluated

The NRC evaluated the environmental impacts of continued storage in three timeframes that begin once the licensed life of the reactor ends—short-term storage, long-term storage, and indefinite storage (see Figure 1-1).

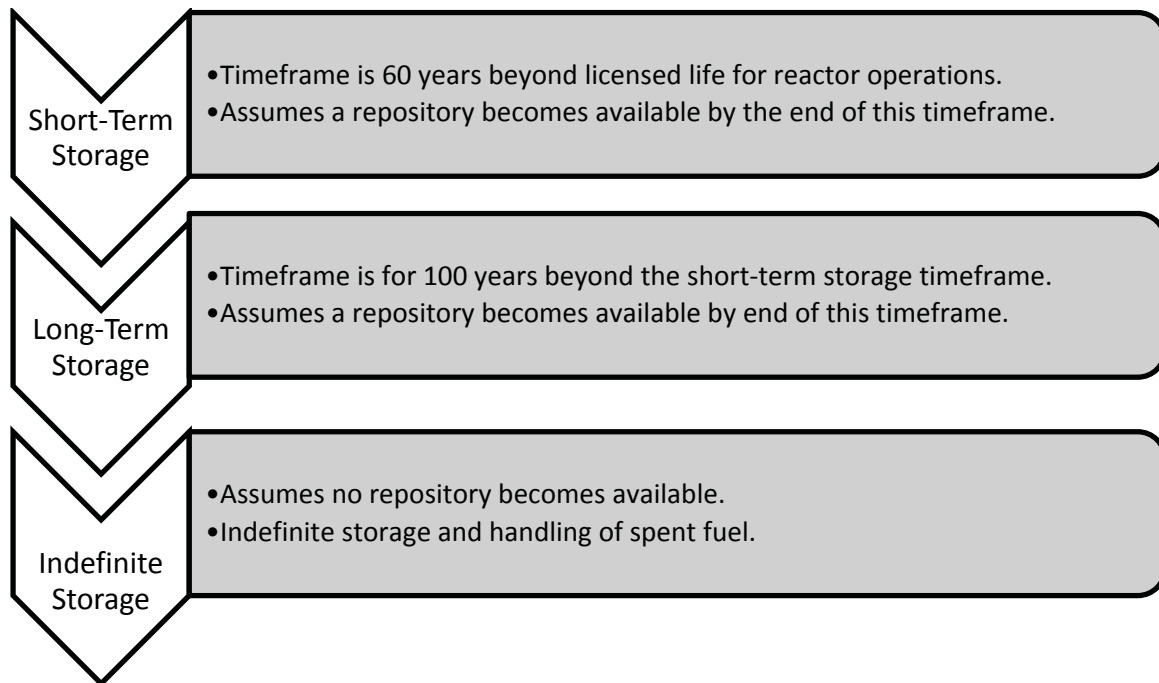

Figure 1-1. Continued Storage Timeframes

The first timeframe—*short-term storage*—lasts for 60 years and begins after the end of a reactor’s licensed life for operations. The NRC evaluated the environmental impacts resulting from the following activities that occur during the short-term storage timeframe:

- continued storage of spent fuel in spent fuel pools (at-reactor only) and ISFSIs,
- routine maintenance of at-reactor spent fuel pools and ISFSIs (e.g., maintenance of concrete pads),
- construction and operation of an away-from-reactor ISFSI (including routine maintenance), and
- handling and transfer of spent fuel from spent fuel pools to ISFSIs.

The next timeframe—*long-term storage*—is 100 years and begins immediately after the short-term storage timeframe. The NRC evaluated the environmental impacts resulting from the following activities that occur during long-term storage:

- continued storage of spent fuel in ISFSIs, including routine maintenance,
- one-time replacement of ISFSIs and spent fuel canisters and casks, and
- construction and operation of a DTS (including replacement).

For the long-term storage timeframe, the NRC assumes that all spent fuel has already been moved from the spent fuel pool to dry cask storage by the end of the short-term storage timeframe. The spent fuel pool would be decommissioned within 60 years after permanent cessation of operation, as required by 10 CFR 50.82 or 10 CFR 52.110.

The third timeframe—*indefinite storage*—assumes that a geologic repository does not become available. In this timeframe, at-reactor and away-from-reactor ISFSIs would continue to store spent fuel in dry casks indefinitely. For the evaluation of environmental impacts if no repository becomes available, the following activities are considered:

- continued storage of spent fuel in ISFSIs, including routine maintenance,
- replacement of ISFSIs and spent fuel canisters and casks every 100 years,
- construction and operation of an away-from-reactor ISFSI (including replacement every 100 years), and
- construction and operation of a DTS (including replacement every 100 years).

These activities are the same as those that would occur for long-term storage, but without a repository, they would occur repeatedly.

1.8.3 Analysis Assumptions

To evaluate the potential environmental impacts of continued storage, this GEIS makes several assumptions.

- Although the NRC recognizes that the precise time spent fuel is stored in pools and dry cask storage systems will vary from one reactor to another, this GEIS makes a number of reasonable assumptions regarding the length of time the fuel can be stored in a spent fuel pool and in a dry cask before the fuel needs to be moved or the facility needs to be replaced. With respect to spent fuel pool storage, the NRC assumes that all spent fuel is removed from the spent fuel pool and placed in dry cask storage in an ISFSI no later than 60 years after the end of the reactor's licensed life for operation. With respect to dry cask storage, the NRC assumes that the licensee uses a DTS during long-term and indefinite storage timeframes to move the spent fuel to a new dry cask every 100 years. Similarly, the NRC assumes that the DTS and the ISFSI pad are replaced every 100 years. For an ISFSI that reaches 100 years of age near the end of the short-term storage timeframe, the NRC assumes that the replacement would occur during the long-term storage timeframe.
- Based on its knowledge of and experience with the structure and operation of the various facilities that will provide continued storage, including the normal life of those facilities, the NRC believes that spent fuel pool storage could last for about 60 years beyond the licensed life for operation of the reactor where it is stored, and that each ISFSI will last about 100 years.

Introduction

- The most reasonably foreseeable assumption is that institutional controls (i.e., the continued regulation of spent fuel) will continue. The assumption that institutional controls will continue enables an appropriate and reasonable evaluation of the environmental impacts of continued storage over an indefinite timeframe. Absent the stability and predictability that follows institutional controls, including but not limited to NRC licensing and regulatory controls, few impacts could be reliably forecast. For the purpose of the analyses in this GEIS, the NRC assumes that regulatory control of radiation safety will remain at the same level of regulatory control as currently exists today. Section B.3.4 of Appendix B provides further discussion regarding institutional controls.
- A DTS will be built at each ISFSI location during the long-term storage timeframe to facilitate spent fuel transfer and handling.
- The NRC assumes a 100-year replacement cycle for spent fuel canisters and casks. This assumption is consistent with assumptions made in the Yucca Mountain Final EIS (DOE 2008).
- The 100-year replacement cycle also assumes replacement of the ISFSI facility and DTS.
- Based on currently available information, the 100-year replacement cycle provides a reasonably conservative assumption for a storage facility that would require replacement at a future point in time. However, this assumption does not mean that dry cask storage systems and facilities *need* to be replaced every 100 years to maintain safe storage.
- Replacement of the entire ISFSI would occur over the course of each 100-year interval, starting at the beginning of the long-term storage timeframe (approximately 100 years after spent fuel would have first been transferred from the spent fuel pool into a dry cask storage system, which would occur about 35 years into a reactor's licensed life for operations).
- The NRC assumes that the land used for the ISFSI pads and DTS would be reclaimed after the facilities are demolished and, therefore, would be used again in the next 100-year replacement cycle. The NRC assumes the initial replacement ISFSI and DTS would be built near the existing facilities. The NRC believes this assumption is reasonable because the characteristics of the previously disturbed land are already known and are suitable for ISFSI and DTS design and construction.
- The NRC assumes that aging management, including routine maintenance activities and programs, occurs between replacements. These "routine" or planned maintenance activities are distinct from the "replacement" of facilities and equipment.
- The spent fuel is moved from the spent fuel pool to dry cask storage within the short-term storage timeframe.
- Under NRC regulations, a nuclear power plant that operates for the term specified in its license is required to complete decommissioning within 60 years after the licensed life for operations in accordance with 10 CFR 50.82 or 52.110. Under these regulations, a plant that permanently ceases operation before the term specified in its operating license is

required to complete decommissioning within 60 years after the permanent cessation of operation. Consistent with this requirement, the NRC assumes that, by the end of the short-term storage timeframe, a licensee will either terminate its Part 50 or Part 52 license and receive a specific Part 72 ISFSI license (see 10 CFR Part 72, Subpart C) or apply to receive Commission approval under 10 CFR 50.82(a)(3) or 52.110(c) to continue decommissioning under its Part 50 or Part 52 license. Accordingly, the NRC would conduct any appropriate site-specific NEPA analysis for either issuance of a Part 72 ISFSI license upon termination of the licensee's Part 50 or Part 52 license or approval to continue decommissioning beyond 60 years after ceasing operations in accordance with 10 CFR 50.82(a)(3) or 52.110(c). Further, the NRC assumes that replacing an ISFSI and licensing a DTS are licensing actions that would be subject to separate site-specific NEPA reviews. The ISFSI and DTS would be decommissioned separately.

- Construction, operation, and replacement of the DTS are assumed to occur within the long-term storage timeframe. If the DTS is built at the beginning of the long-term storage timeframe, it could be near the end of its useful life by the end of that storage timeframe. To be conservative, the NRC included the impacts of replacing the DTS one time during the long-term storage timeframe.
- Because an away-from-reactor ISFSI could store fuel from several different reactors, the earliest an away-from-reactor ISFSI would enter the short-term timeframe is when the first of these reactors reaches the end of its licensed life for operation.
- The amount of spent fuel generated is based on the assumption that the nuclear power plant operates for 80 years (40-year initial term plus two 20-year renewed terms).⁴
- A typical spent fuel pool of 700 metric tons of uranium storage capacity reaches its licensed capacity limit about 35 years into the licensed life for operation of a reactor. At that point, some of the spent fuel would need to be removed from the spent fuel pool and transferred to a dry cask storage system at either an at-reactor or away-from-reactor ISFSI.
- The environmental impacts of constructing a “spent fuel pool island,” which allows the spent fuel pool to be isolated from other reactor plant systems to facilitate decommissioning, are considered within the analysis of cumulative effects in Chapter 6. Because a new spent fuel pool cooling system would be smaller in size and have fewer associated impacts than existing spent fuel pool cooling systems, the environmental impacts of operating the new spent fuel pool cooling system in support of continued storage in the spent fuel pool, would be bound by the impacts of operating the existing cooling system described in Chapter 4.
- It is assumed that an ISFSI of sufficient size to hold all spent fuel generated will be constructed during the licensed life for operation.

⁴ The Commission's regulations provide that renewed operating licenses may be subsequently renewed, although no licensee has yet submitted an application for such a subsequent renewal. This GEIS included two renewals as a conservative assumption in evaluating potential environmental impacts.

Introduction

- Sufficient low-level waste (LLW) disposal capacity will be made available when needed. Historically, the demand for LLW disposal capacity has been met by private industry. The NRC expects that this trend will continue in the future. For example, in response to demand for LLW disposal capacity, Waste Control Specialists, LLC, opened a LLW disposal facility in Andrews County, Texas, on April 27, 2012.

The analyses in this GEIS are based on current technology and regulations. Appendix B provides further information supporting the analysis assumptions. These analyses are not intended to be, and should not be interpreted as, representative of any specific storage facility or site in the United States where spent fuel is currently stored or could be stored in the future.

1.8.4 Other Environmental Analyses

Numerous NRC proceedings, regulations, or NEPA documents address the environmental impacts of other NRC-regulated activities: the licensed life for operation of a commercial nuclear power facility, the licensed life of an ISFSI, spent fuel transportation, the nuclear fuel cycle, license termination, and ultimate spent fuel disposal. This is depicted in Figure 1-2. A brief description of these other NEPA documents and regulations is presented below. NEPA documents used to support the analyses in this GEIS are listed in Table 1-1.

The storage of spent fuel *during* the initial licensed term for operation of a nuclear reactor is considered within the site-specific EIS for either a [10 CFR Part 50](#) or [10 CFR Part 52](#) licensing review.

The impacts from renewing the operating licenses for commercial nuclear power plants for up to an additional 20 years are evaluated in site-specific EISs, which tier off the License Renewal GEIS (NRC 2013d). The License Renewal GEIS addresses spent fuel storage *during* the license renewal term. The findings from the License Renewal GEIS with respect to environmental impacts of continued nuclear power plant operations have been codified in regulation (in [10 CFR Part 51, Table B-1 of Appendix B to Subpart A](#)).

The impacts from storage of spent fuel during the initial and renewed licensed terms of an ISFSI are addressed in site-specific NEPA reviews for licensees that elect to construct ISFSIs with specific licenses under 10 CFR Part 72. For those licensees that elect to construct an ISFSI under a general license, the environmental review has already been conducted and documented in an EA (NRC 1989).

The impacts from decommissioning nuclear power plants have previously been evaluated in *Final Generic Environmental Impact Statement on Decommissioning of Nuclear Facilities Supplement 1 Regarding the Decommissioning of Nuclear Power Reactors Main Report* (Decommissioning GEIS) (NRC 2002).

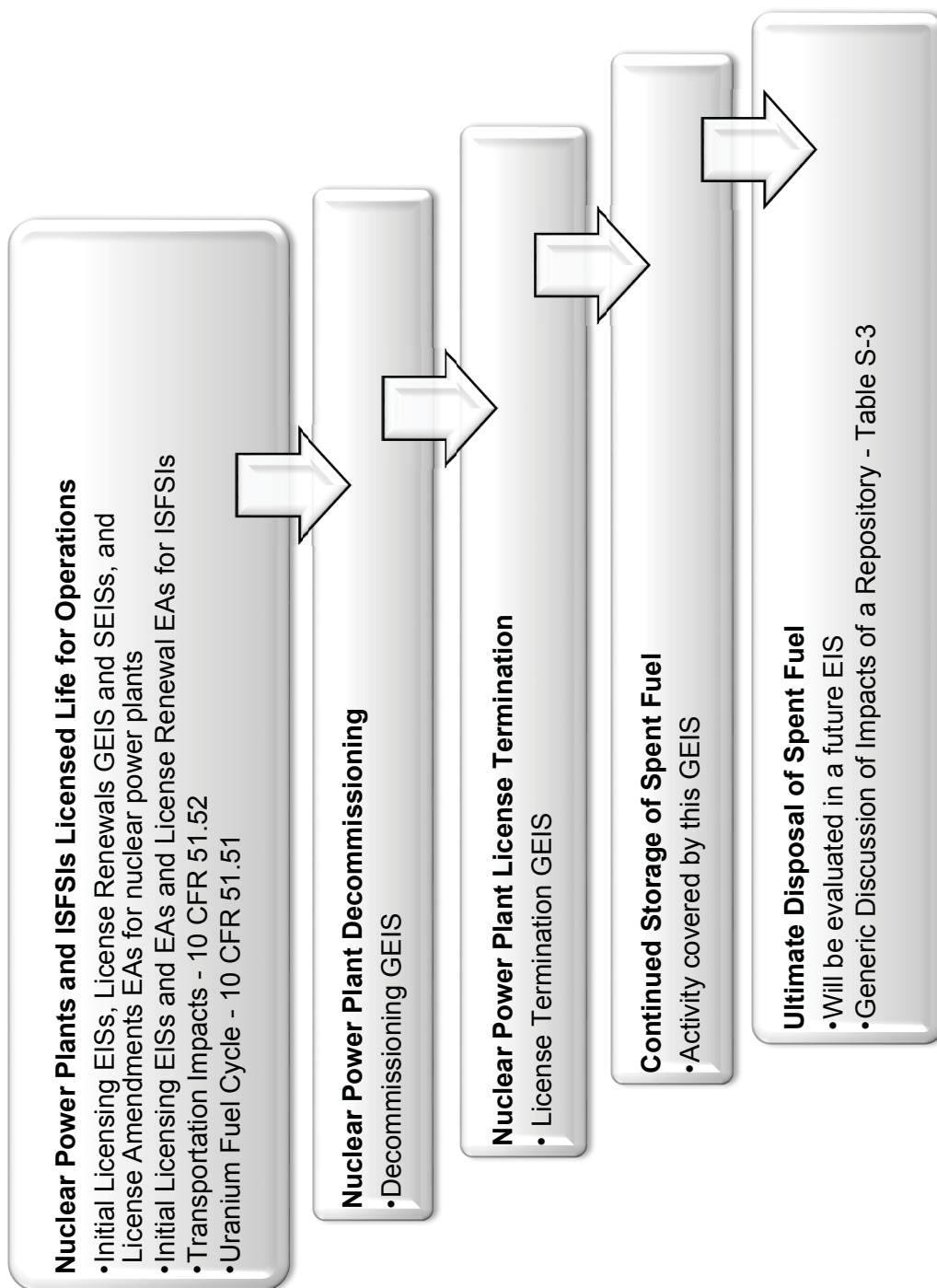

Figure 1-2. NEPA Analyses for NRC Activities

Introduction

Table 1-1. List of NEPA Documents Used in Preparation of this GEIS

Document	Agency	Date	Availability
Final EIS for a Geologic Repository for the Disposal of Spent Nuclear Fuel and High-Level Radioactive Waste at Yucca Mountain, Nye County, Nevada and its supplements	DOE	June 2008	Online at www.energy.gov ML081750212 ^(a)
Generic EISs			
Final Generic EIS on Decommissioning of Nuclear Facilities Supplement 1 Regarding the Decommissioning of Nuclear Power Reactors	NRC	November 2002	NUREG-0586 ^(b) ML023470323
Final Generic EIS on Handling and Storage of Spent Light Water Power Reactor Fuel	NRC	August 1979	NUREG-0575 ^(b) ML022550127
ISFSI Licensing			
EA for 10 CFR Part 72 Licensing Requirements for the Independent Storage of Spent Fuel and High-Level Radioactive Waste	NRC	August 1984	NUREG-1092 ^(b) ML091050510
EA for 10 CFR Part 72 Proposed Rule on Storage of Spent Nuclear Fuel in NRC-Approved Storage Casks at Nuclear Power Reactor Sites	NRC	March 1989	ML051230231
Final EIS for the Construction and Operation of an Independent Spent Nuclear Fuel Storage Installation on the Reservation of the Skull Valley Band of Goshute Indians and Related Transportation Facility in Tooele County, Utah	NRC	December 2001	NUREG-1714 ^(b) ML020150217
Environmental Assessment Related to the Construction and Operation of the H.B. Robinson Independent Spent Fuel Storage Installation	NRC	March 1986	ML060200531 ^(a)
Environmental Assessment for the Trojan Independent Spent Fuel Storage Installation	NRC	November 1996	ML060410416 ^(a)
Environmental Assessment for the License Renewal of the General Electric Morris Operation Independent Spent Fuel Storage Installation in Morris, Illinois	NRC	November 2004	ML043360415 ^(a)

Table 1-1. List of NEPA Documents Used in Preparation of this GEIS (cont'd)

Document	Agency	Date	Availability
Final Environmental Impact Statement for the Construction and Operation of an Independent Spent Fuel Storage Installation to Store the Three Mile Island Unit 2 Spent Fuel at the Idaho National Engineering and Environmental Laboratory	NRC	March 1998	NUREG-1626 ^(b) ML123480202
Environmental Assessment Related to the Construction and Operation of the Oconee Nuclear Station Independent Spent Fuel Storage Installation - Redacted	NRC	October 1988	ML123480209 ^(a) (Redacted)
Environmental Assessment Related to the Construction and Operation of the Calvert Cliffs Independent Spent Fuel Storage Installation – Redacted	NRC	March 1991	ML123480177 ^(a) (Redacted)
Environmental Assessment for Proposed Renewal of Calvert Cliffs Nuclear Power Plant Independent Spent Fuel Storage Installation	NRC	April 2012	ML121220084 ^(a)
Environmental Assessment Related to the Construction and Operation of the Fort St. Vrain Independent Spent Fuel Storage Installation	NRC	February 1991	ML123480181 ^(a) (Redacted)
Environmental Assessment Related to the Construction and Operation of the Humboldt Bay Independent Spent Fuel Storage Installation	NRC	October 2005	ML052430106
Notice of Issuance of Environmental Assessment and Finding of No Significant Impact for the Diablo Canyon Independent Spent Fuel Storage Installation	NRC	October 2003	ML032970369
Environmental Assessment Related to the Construction and Operation of the Rancho Seco Independent Spent Fuel Storage Installation	NRC	August 1994	ML123480187 ^(a) (Redacted)
Environmental Assessment Related to the Construction and Operation of the North Anna Independent Spent Fuel Storage Installation	NRC	March 1997	ML123480192 ^(a) (Redacted)

Table 1-1. List of NEPA Documents Used in Preparation of this GEIS (cont'd)

Document	Agency	Date	Availability
Reactor License Renewals			
Generic Environmental Impact Statement for License Renewal of Nuclear Plants, Rev. 1	NRC	May 2013	NUREG-1437^(b) Vol. 1 ML13106A241 Vol. 2. ML13106A242 Vol. 3. ML13106A244
Supplemental Environmental Impact Statement for Wolf Creek Generating Station License Renewal	NRC	May 2008	NUREG-1437, Supplement 32^(b)
New Reactor Licensing			
Environmental Impact Statement for the Combined License (COL) for Enrico Fermi Unit 3	NRC	January 2013	NUREG-2105^(b) Vol. 1 ML12307A172 Vol. 2 ML12307A176 Vol. 3 ML12307A177 Vol. 4 ML12307A202
Environmental Impact Statement for Combined Licenses (COLs) for South Texas Project Electric Generating Station Units 3 and 4	NRC	February 2011	NUREG-1937^(b) Vol. 1 ML111290826 Vol. 2 ML11049A001
Environmental Impact Statement for the Combined License (COL) for Calvert Cliffs Nuclear Power Plant Unit 3	NRC	May 2011	NUREG-1936^(b) ML12026A658
Final Environmental Impact Statement for Combined Licenses (COLs) for William States Lee III Nuclear Station Units 1 and 2	NRC	December 2013	NUREG-2111 Vol. 1 ML13340A005 Vol. 2 ML13340A006 Vol. 3 ML13340A007
Previous Waste Confidence Rules and Decisions			
<i>Federal Register</i> Notice – “Consideration of Environmental Impacts of Temporary Storage of Spent Fuel After Cessation of Reactor Operation; Waste Confidence Decision Update; Final Rules”	NRC	December 2010	75 FR 81032
<i>Federal Register</i> Notice – “Waste Confidence Decision Review: Status”	NRC	December 1999	64 FR 68005
<i>Federal Register</i> Notice – “Consideration of Environmental Impacts of Temporary Storage of Spent Fuel After Cessation of Reactor Operation; and Waste Confidence Decision Review; Final Rules”	NRC	September 1990	55 FR 38472

Table 1-1. List of NEPA Documents Used in Preparation of this GEIS (cont'd)

Document	Agency	Date	Availability
<i>Federal Register</i> Notice – “Waste Confidence Decision and Requirements for Licensee Actions Regarding the Disposition of Spent Fuel Upon Expiration of Reactor Operating Licenses; Final Rules”	NRC	August 1984	49 FR 34658
(a) ADAMS can be accessed online . Accession numbers are provided for EAs.			
(b) NUREGs can be found online at the NRC website .			

The environmental impacts of portions of the uranium fuel cycle that occur before new fuel is delivered to the plant and after spent fuel is sent to a disposal site have been evaluated and are codified in regulation ([10 CFR 51.51, Table S-3](#)).

Impacts from the transportation of fuel and waste to and from a nuclear power reactor are codified in regulation ([10 CFR 51.52, Table S-4](#)).

The environmental impacts of residual radioactivity remaining after license termination are addressed in the *Generic Environmental Impact Statement in Support of Rulemaking on Radiological Criteria for License Termination of NRC-Licensed Nuclear Facilities: Final Report* (License Termination Rule GEIS) (NRC 1997).

The environmental impacts of a specific geologic repository will be addressed in the EIS that the DOE is required to submit for any geologic repository application that it submits.

1.8.5 Significance of Environmental Impacts

The NRC has established a standard of *significance* for assessing environmental issues. In NRC environmental reviews, significance indicates the importance of likely environmental impacts and is determined by considering two variables: *context* and *intensity*. Context is the geographic, biophysical, and social setting in which the effects will occur. Intensity refers to the severity of the impact, in whatever context it occurs. The NRC uses a three-level standard of significance based upon the President’s Council on Environmental Quality guidelines (40 CFR 1508.27):

SMALL—Environmental effects are not detectable or are so minor that they will neither destabilize nor noticeably alter any important attribute of the resource. For the purposes of assessing radiological impacts, the Commission has concluded that radiological impacts that do not exceed permissible levels in the Commission’s regulations are considered small.

Introduction

MODERATE—Environmental effects are sufficient to alter noticeably, but not to destabilize, important attributes of the resource.

LARGE—Environmental effects are clearly noticeable and are sufficient to destabilize important attributes of the resource.

For issues in which the significance determination is based on risk (i.e., the probability of occurrence as well as the potential consequences), the probability of occurrence, as well as the potential consequences, have been factored into the determination of significance. For some resource areas, the impact determination language is specific to the authorizing regulation, executive order, or guidance.

1.8.6 Issues Eliminated from Review in this GEIS

The NRC is evaluating the continued storage of commercial spent fuel in this GEIS. Thus, certain topics are not addressed because they are not within the scope of this review. These topics include:

- noncommercial spent fuel (e.g., defense waste),
- commercial HLW generated from reprocessing,
- greater-than-class-C LLW,
- advanced reactors (e.g., high-temperature and gas-cooled reactors),
- foreign spent fuel,
- nonpower reactor (e.g., test and research reactors),
- need for nuclear power, and
- reprocessing of commercial spent fuel.

The *Waste Confidence Generic Environmental Impact Statement Scoping Process Summary Report* (NRC 2013c) and Appendix D provide additional details on topics that are considered out of scope for this GEIS.

1.8.7 GEIS Contents

The subsequent chapters of this GEIS are organized as follows. Chapter 2 describes typical facility characteristics and activities that are used to assess environmental impacts of continued storage. Chapter 3 describes the affected environment. Chapters 4 and 5 include analyses of potential environmental impacts of at-reactor storage (Chapter 4) and away-from-reactor storage (Chapter 5). Chapter 6 evaluates the cumulative impacts of continued storage with other reasonable past, present, and reasonably foreseeable actions. Chapter 7 provides cost-benefit analyses of the proposed action and the NRC's options in the case of no action, as well

as the NRC's recommendation on which alternative (the proposed action or no action) is the preferred alternative. Chapter 8 summarizes the environmental impacts of continued storage analyzed in the preceding chapters. Chapter 9 provides a list of the staff who authored this GEIS. Chapter 10 provides an index of terms used throughout the GEIS and Chapter 11 provides a glossary.

Appendices to this GEIS provide the following additional information:

- Appendix A – Scoping Comments
- Appendix B – Technical Feasibility of Continued Storage and Repository Availability
- Appendix C – Outreach and Correspondence
- Appendix D – Draft GEIS and Proposed Rule Comment Summaries and Responses
- Appendix E – Analysis of Spent Fuel Pool Leaks
- Appendix F – Spent Fuel Pool Fires
- Appendix G – Spent Fuel Storage Facilities
- Appendix H – Estimated Costs of Alternatives
- Appendix I – High-Burnup Fuel.

1.9 Other Applicable Federal Requirements

Atomic Energy Act of 1954, as amended – The Atomic Energy Act of 1954, as amended, provides fundamental jurisdictional authority to the DOE and the NRC over governmental and commercial use of nuclear materials. This Act ensures proper management, production, possession, and use of radioactive materials. To comply with the Act, the NRC has established requirements published in Title 10 of the *Code of Federal Regulations*.

This Act gives the NRC authority to regulate the possession, transfer, storage, and disposal of nuclear materials, as well as aspects of transportation packaging design for radioactive materials that include testing for packaging certification. This Act gives the EPA the authority to develop standards for the protection of the environment and public health from radioactive material.

National Environmental Policy Act of 1969, as amended – The NRC has prepared this GEIS in accordance with the NRC's implementing regulations for NEPA (10 CFR Part 51).

Energy Reorganization Act of 1974, as amended – The Energy Reorganization Act of 1974 (Act of 1974), as amended, established the NRC. Under the Atomic Energy Act of 1954, a single agency, the Atomic Energy Commission, had responsibility for the development and production of nuclear weapons and for both the development and the safety regulation of the civilian uses of nuclear materials. The Act of 1974 split these functions, assigning to one

Introduction

agency, now the DOE, the responsibility for the development and production of nuclear weapons, promotion of nuclear power, and other energy-related work, and assigning to the NRC the regulatory work, which does not include regulation of defense nuclear facilities. The Act of 1974 gave the Commission its collegial structure and established its major offices. The later amendment to the Act of 1974 also provided protections for employees who identify nuclear safety concerns.

Nuclear Waste Policy Act of 1982, as amended – The Nuclear Waste Policy Act provides for the research and development of repositories for the disposal of high-level radioactive waste, spent fuel, and low-level radioactive waste. The Act assigns responsibility for the construction of a deep geologic repository to the DOE.

Administrative Procedure Act of 1946, as amended – The Administrative Procedure Act is the fundamental law governing the processes of Federal administrative agencies. It requires, for example, that affected persons be given adequate notice of proposed rules and an opportunity to comment on the proposed rules. This Act gives interested persons the right to petition an agency for the issuance, amendment, or repeal of a rule. It also provides standards for judicial review of agency actions.

The Administrative Procedure Act has been amended often and now incorporates several other acts. Three of these incorporated acts deal with access to information: The Freedom of Information Act, The Government in the Sunshine Act, and The Privacy Act. The Freedom of Information Act requires that agencies make public their rules, adjudicatory decisions, statements of policy, instructions to staff that affect a member of the public, and, upon request, other material that does not fall into one of the act's exceptions for material dealing with national security, trade secrets, and other sensitive information. The Government in the Sunshine Act requires that collegial bodies such as the Commission hold their meetings in public, with certain exceptions for meetings on matters such as national security. The Privacy Act limits release of certain information about individuals.

Two other incorporated acts are noteworthy: The Regulatory Flexibility Act and The Congressional Review Act. The Regulatory Flexibility Act requires that agencies consider the special needs and concerns of small entities in conducting rulemaking. The Congressional Review Act requires that every agency rule be submitted to Congress before being made effective, and that, before being made effective, every "major" rule sit before Congress for 60 days, during which time the rule can be subjected to an accelerated process that can lead to a statutory modification or disapproval of the rule.

1.10 References

10 CFR Part 50. *Code of Federal Regulations*, Title 10, *Energy*, Part 50, “Domestic Licensing of Production and Utilization Facilities.” Washington, D.C.

10 CFR Part 51. *Code of Federal Regulations*, Title 10, *Energy*, Part 51, “Environmental Protection Regulations for Domestic Licensing and Related Regulatory Functions.” Washington, D.C.

10 CFR Part 52. *Code of Federal Regulations*, Title 10, *Energy*, Part 52, “Licenses, Certifications, and Approvals for Nuclear Power Plants.” Washington, D.C.

10 CFR Part 72. *Code of Federal Regulations*, Title 10, *Energy*, Part 72, “Licensing Requirements for the Independent Storage of Spent Nuclear Fuel, High-Level Radioactive Waste, and Reactor-Related Greater Than Class C Waste.” Washington, D.C.

40 CFR Parts 1500 through 1508. *Code of Federal Regulations*, Title 40, *Protection of Environment*, Parts 1500 “Purpose, Policy, and Mandate” through 1508 “Terminology and Index.” Washington, D.C.

42 FR 34391. July 5, 1977. “Denial of Petition for Rulemaking.” *Federal Register*, U.S. Nuclear Regulatory Commission, Washington, D.C.

44 FR 61372. October 25, 1979. “Storage and Disposal of Nuclear Waste.” *Federal Register*, U.S. Nuclear Regulatory Commission, Washington, D.C.

49 FR 34658. August 31, 1984. “Waste Confidence Decision and Requirements for Licensee Actions Regarding the Disposition of Spent Fuel Upon Expiration of Reactor Operating Licenses; Final Rules.” *Federal Register*, U.S. Nuclear Regulatory Commission, Washington, D.C.

49 FR 34688. August 31, 1984. “Waste Confidence Decision.” *Federal Register*, U.S. Nuclear Regulatory Commission, Washington, D.C.

55 FR 38472. September 18, 1990. “Consideration of Environmental Impacts of Temporary Storage of Spent Fuel After Cessation of Reactor Operation; and Waste Confidence Decision Review; Final Rules.” *Federal Register*, U.S. Nuclear Regulatory Commission, Washington, D.C.

55 FR 38474. September 18, 1990. “Waste Confidence Decision Review.” *Federal Register*, U.S. Nuclear Regulatory Commission, Washington, D.C.

Introduction

64 FR 68005. December 6, 1999. “Waste Confidence Decision Review: Status.” *Federal Register*, U.S. Nuclear Regulatory Commission, Washington, D.C.

74 FR 66589. December 16, 2009. “Draft Technical Basis for Rulemaking Revising Security Requirements for Facilities Storing SNF and HLW; Notice of Availability and Solicitation of Public Comments.” *Federal Register*, U.S. Nuclear Regulatory Commission, Washington D.C.

75 FR 81032. December 23, 2010. “Consideration of Environmental Impacts of Temporary Storage of Spent Fuel After Cessation of Reactor Operation; Waste Confidence Decision Update; Final Rules.” *Federal Register*, U.S. Nuclear Regulatory Commission, Washington, D.C.

75 FR 81037. December 23, 2010. “Waste Confidence Decision Update.” *Federal Register*, U.S. Nuclear Regulatory Commission, Washington, D.C.

77 FR 63254. October 16, 2012. “Petition for Rulemaking Submitted by C-10 Research and Education Foundation, Inc.” *Federal Register*, U.S. Nuclear Regulatory Commission, Washington, D.C.

77 FR 65137. October 25, 2012. “Consideration of Environmental Impacts of Temporary Storage of Spent Fuel After Cessation of Reactor Operation.” *Federal Register*, U.S. Nuclear Regulatory Commission, Washington, D.C.

78 FR 56695. September 13, 2013. “Environmental Impacts Statements; Notice of Availability.” *Federal Register*, U.S. Environmental Protection Agency, Washington, D.C.

78 FR 66858. November 7, 2013. “Waste Confidence—Continued Storage of Spent Nuclear Fuel.” *Federal Register*, U.S. Nuclear Regulatory Commission, Washington, D.C.

Administrative Procedures Act, as amended. 5 USC 500, *et seq.*

Atomic Energy Act of 1954, as amended. 42 USC 2011 *et seq.*

Congressional Review Act. 5 USC 801–808.

DOE (U.S. Department of Energy). 2008. *Final Supplemental Environmental Impact Statement for a Geologic Repository for the Disposal of Spent Nuclear Fuel and High-Level Radioactive Waste at Yucca Mountain, Nye County, Nevada*. DOE EIS–0250F–S1, Office of Civilian Radioactive Waste Management, Las Vegas, Nevada. Accession No. ML081750212.

DOE (U.S. Department of Energy). 2013. *Strategy for the Management and Disposal of Used Nuclear Fuel and High-Level Radioactive Waste*. Washington, D.C. Accession No. ML13011A138.

Energy Reorganization Act of 1974, as amended. 42 USC 5801 *et seq.*

Freedom of Information Act. 5 USC 552.

Government in the Sunshine Act of 1976. 5 USC 552b.

Minnesota v. NRC (U.S. Nuclear Regulatory Commission). 602 F.2d 412 (D.C. Cir. 1979).

National Environmental Policy Act of 1969 (NEPA), as amended. 42 USC 4321 *et seq.*

New York v. NRC (State of New York et al. v. U.S. Nuclear Regulatory Commission). 681 F.3d 471 (D.C. Cir. 2012). Accession No. ML12191A407.

NRC (U.S. Nuclear Regulatory Commission). 1984. *Environmental Assessment for 10 CFR Part 72 "Licensing Requirements for the Independent Spent Fuel and High-Level Radioactive Waste."* NUREG–1092, Washington, D.C. ML091050510.

NRC (U.S. Nuclear Regulatory Commission). 1989. *Environmental Assessment and Finding of No Significant Impact for Proposed Rule Entitled, "Storage of Spent Nuclear Fuel in NRC-Approved Storage Casks at Nuclear Power Reactor Sites."* Washington, D.C. Accession No. ML051230231.

NRC (U.S. Nuclear Regulatory Commission). 1997. *Generic Environmental Impact Statement in Support of Rulemaking on Radiological Criteria for License Termination of NRC-Licensed Nuclear Facilities: Final Report*. NUREG–1497, Volume 1, Washington, D.C. Accession No. ML042310492.

NRC (U.S. Nuclear Regulatory Commission). 2001. *Final Environmental Impact Statement for the Construction and Operation of an Independent Spent Nuclear Fuel Storage Installation on the Reservation of the Skull Valley Band of Goshute Indians and Related Transportation Facility in Tooele County, Utah*. NUREG–1714, Volume 1, Washington, D.C. Accession No. ML020150170.

NRC (U.S. Nuclear Regulatory Commission). 2002. *Final Generic Environmental Impact Statement on Decommissioning of Nuclear Facilities Supplement 1 Regarding the Decommissioning of Nuclear Power Reactors Main Report*. NUREG–0586, Supplement 1, Volume 1, Washington, D.C. Accession No. ML023470323.

NRC (U.S. Nuclear Regulatory Commission). 2003. *Environmental Review Guidance for Licensing Actions Associated with NMSS Programs: Final Report*. NUREG–1748, Washington, D.C. Accession No. ML032450279.

NRC (U.S. Nuclear Regulatory Commission). 2012a. Memorandum and Order dated August 7, 2012, regarding "Petition to Suspend Final Decision on All Pending Reactor Licensing

Introduction

Proceedings.” Commission Order CLI-12-16, Washington, D.C. Accession No. ML12220A094.

NRC (U.S. Nuclear Regulatory Commission). 2012b. Memorandum from A.L. Vietti-Cook to R.W. Borchardt, dated September 6, 2012, regarding “Staff Requirements—COMSECY-12-0016—Approach for Addressing Policy Issues Resulting from Court Decision to Vacate Waste Confidence Decision and Rule.” SRM-COMSECY-12-0016, Washington, D.C. Accession No. ML12250A032.

NRC (U.S. Nuclear Regulatory Commission). 2012c. Memorandum from R.W. Borchardt to Chairman McFarlane and Commissioners Svinicki, Apostolakis, Magwood, and Ostendorff, dated July 9, 2012, regarding “Approach for Addressing Policy Issues Resulting from Court Decision to Vacate Waste Confidence Decision and Rule.” COMSECY-12-0016, Washington, D.C. Accession No. ML12180A424.

NRC (U.S. Nuclear Regulatory Commission). 2012d. *Program Plans for Tier 3 Recommendations*. SECY-12-0095, Washington, D.C. Accession Nos. ML12208A208 (SECY); ML12165A092 (Enclosure 1); ML12165A093 (Enclosure 2); ML12208A210 (Enclosure 3).

NRC (U.S. Nuclear Regulatory Commission). 2012e. *Summary of Public Scoping Meetings for Environmental Impact Statement to Support Waste Confidence Rulemaking*. Washington, D.C. Accession No. ML12339A281.

NRC (U.S. Nuclear Regulatory Commission). 2012f. *Summary of Public Scoping Webinars for the Environmental Impact Statement to Support the Waste Confidence Rulemaking*. Washington, D.C. Accession No. ML12356A293.

NRC (U.S. Nuclear Regulatory Commission). 2013a. “NRC Staff’s Evaluation of Public and Stakeholder Comments on the Draft Regulatory Basis for a Rulemaking Revising Security Requirements for Facilities Storing SNF and HLW.” Washington, D.C. Accession No. ML13085A150.

NRC (U.S. Nuclear Regulatory Commission). 2013b. “Staff Evaluation and Recommendation for Japan Lessons-Learned Tier 3 Issue on Expedited Transfer of Spent Fuel.” Washington, D.C. Accession Nos. ML13273A601, ML13273A628.

NRC (U.S. Nuclear Regulatory Commission). 2013c. *Waste Confidence Generic Environmental Impact Statement Scoping Process Summary Report*. Washington, D.C. Accession No. ML13060A128.

NRC (U.S. Nuclear Regulatory Commission). 2013d. *Generic Environmental Impact Statement for License Renewal of Nuclear Plants*. NUREG-1437, Revision 1, Washington, D.C. Accession No. ML13107A023.

NRC (U.S. Nuclear Regulatory Commission). 2014a. Memorandum from R.C. Bovol to M.A. Satorius dated May 23, 2014, “Staff-Requirements—COMSECY-13-0300—Staff Evaluation and Recommendation for Japan Lessons-Learned Tier 3 Issue on Expedited Transfer of Spent Fuel.” Washington, D.C. Accession No. ML14143A360.

NRC (U.S. Nuclear Regulatory Commission). 2014b. *Comments on the Waste Confidence Draft Generic Environmental Impact Statement and Proposed Rule*. Washington, D.C. Accession No. ML1415A175.

NRDC v. NRC (Natural Resources Defense Council v. U.S. Nuclear Regulatory Commission). 582 F.2d 166 (2d Cir. 1978).

Nuclear Waste Policy Act of 1982, as amended. 42 USC 10101 *et seq.*

Privacy Act of 1974. 5 USC 552a.

Regulatory Flexibility Act of 1981. 5 USC 601–612.

2.0 Generic Facility Descriptions and Activities

This chapter describes typical facility characteristics and activities that are within the scope of this GEIS. The U.S. Nuclear Regulatory Commission (NRC) relied upon available information for facilities and activities similar to those described in this chapter to assess environmental impacts that may occur from continued storage of spent nuclear fuel (spent fuel) beyond the licensed life for operation of a reactor (continued storage).

2.1 Generic Facility Descriptions

Most commercial spent fuel is stored at reactor sites in spent fuel pools and at-reactor independent spent fuel storage installations (ISFSIs). Some commercial spent fuel is stored under NRC regulatory oversight at away-from-reactor ISFSIs such as the GE-Hitachi Nuclear Energy Americas, LLC, Morris wet storage facility in Morris, Illinois, (GEH Morris) and the U.S. Department of Energy's (DOE) Three Mile Island, Unit 2, Fuel Debris ISFSI at the Idaho National Engineering Laboratory.^{1,2} The remainder of the commercial spent fuel has either been reprocessed at the former Nuclear Fuel Services reprocessing facility in western New York State or removed from reactor sites by the DOE, or its predecessor agencies, and is no longer regulated by the NRC. The spent fuel addressed by the generic analysis in this generic environmental impact statement (GEIS) is the commercial spent fuel regulated by the NRC. Spent fuel or commercial high-level waste derived from reprocessing of spent fuel under the control of other agencies of the Federal government is not included in this generic analysis. Additional information on the scope of this GEIS is presented in Chapter 1.

The following sections provide generic descriptions of NRC-licensed facilities that store commercial spent fuel, with an emphasis on characteristics relevant to continued storage. These descriptions provide physical context for the generic activities described in Section 2.2. In addition, this section provides construction costs for continued storage facilities, as well as costs (e.g., rail spurs) for transporting spent fuel to an away-from-reactor ISFSI during

¹ The DOE holds three ISFSI licenses from the NRC: (1) the Fort St. Vrain at-reactor ISFSI in Platteville, Colorado; (2) the away-from-reactor Three Mile Island ISFSI; and (3) the yet-to-be-constructed away-from-reactor Idaho Spent Fuel Facility.

² In 2006, the NRC granted a license to Private Fuel Storage, LLC (PFS), to construct and operate an away-from-reactor ISFSI in Skull Valley, Utah. PFS has not constructed the proposed ISFSI. See Section 2.1.3 for additional information regarding this project.

Generic Facility Descriptions and Activities

continued storage (analyzed in Chapter 5). The estimated costs presented in this chapter are expressed in 2014 dollars.³

2.1.1 At-Reactor Continued Storage Site Descriptions

The following sections describe the general characteristics of at-reactor continued storage sites, which are identical to nuclear power plant sites.

2.1.1.1 General Description of Single-Unit Nuclear Power Plant Site

This section describes a generic single-unit nuclear power plant site, which is where continued storage will occur in spent fuel pools and at-reactor ISFSIs. Key differences between a single-unit site and multiple-unit site, relevant to continued storage, are described in Section 2.1.1.2.

A nuclear power plant site, including its associated ISFSI, contains a number of buildings or structures. Among them are a containment building or reactor building, turbine building, auxiliary building, vent stacks, meteorological towers, and cooling systems (which may include cooling towers). A nuclear power plant also includes large parking areas, security fencing, switchyards, water-intake and -discharge facilities, and transmission lines.⁴ While reactor, turbine, and auxiliary buildings are often clad or painted in colors that are intended to reduce or mitigate their visual presence, the heights of many of the structures, coupled with safety lights, make power plants visible from many directions and from great distances. Typical heights of structures found on these facilities are as follows: reactor buildings are 90 m (300 ft), turbine buildings are 30 m (100 ft), stacks are 90 m (300 ft), meteorological towers are 60 m (200 ft), natural draft cooling towers are higher than 150 m (500 ft), and mechanical draft cooling towers

³ Estimated costs from sources older than 2014 are adjusted to 2014 dollars following the Bureau of Labor Statistics (BLS) inflation calculator method (BLS 2014a), which uses the annual average Consumer Price Index (CPI) for a given year. The BLS CPI inflation calculator uses the following formula:

$$2014 \text{ cost} = \left(\frac{\text{March 2014 CPI}}{\text{year "X" annual average CPI}} \right) \text{year "X" cost}$$

The following annual average CPI values (BLS 2014b) were used to calculate estimated costs in 2014 dollars in this chapter: 236.293 (March 2014), 229.594 (2012), 218.056 (2010), 214.537 (2009), 188.9 (2004), and 152.4 (1995). The NRC recognizes that the CPI may not fully capture the changes in costs for various construction, operation, design, procurement, and licensing activities; however, using the CPI provides the NRC with a means of developing more comparable estimates than using non-adjusted figures from disparate years.

⁴ The term "power block" is sometimes used to refer to the buildings and components directly involved in generating electricity at a power plant. At a nuclear power plant, the components of the power block vary with the reactor design, but always include the reactor and turbine building, and usually include several other buildings that house access, reactor auxiliary, safeguards, waste processing, or other nuclear generation support functions.

are 30 m (100 ft) tall. Transmission-line towers are between 20 and 50 m (70 and 170 ft) in height, depending on the voltage being carried (NRC 2013a).

There are two types of power reactors currently in use in the United States—boiling water reactors (BWRs) and pressurized water reactors (PWRs). In general, all nuclear power plant sites, when operating, are similar in terms of the types of onsite structures; however, the layout of buildings and structures varies considerably among the sites. In addition, while these buildings and structures are necessary during operations, many of the structures may be removed, mothballed, or entombed as a result of the decommissioning process, depending on several factors, including the decommissioning option licensees choose and other operational considerations. Many of these structures will be present at the beginning of continued storage analyzed in this GEIS. As decommissioning of the reactor facility progresses, the number of onsite structures will decline until only continued storage-related structures are present at the beginning of the long-term storage timeframe. The following list describes typical structures located on most sites following the permanent cessation of reactor operations (NRC 2013a):

- *Containment or reactor building.* The containment or reactor building of a PWR is a massive concrete or steel structure that houses the reactor vessel, reactor coolant piping and pumps, steam generators, pressurizer, pumps, and associated piping. In general, the reactor building of a BWR includes a containment structure and a shield building. The reactor-containment building is a massive steel and concrete structure that houses the reactor vessel, the reactor coolant piping and pumps, and the suppression pool. It is located inside a shield building.
- *Fuel building.* For PWRs, the fuel building has a fuel pool that is used to store and service spent fuel and prepare new fuel for insertion into the reactor. This building is connected to the reactor-containment building by a transfer tube or channel that is used to move new fuel into the reactor and move spent fuel out of the reactor for storage. For plants with a BWR/6 reactor, spent fuel is stored in an adjacent Fuel Building or Fuel-Handling Building.
- *Turbine building.* The turbine building houses the turbine generators, condenser, feedwater heaters, condensate and feedwater pumps, waste-heat rejection system, pumps, and equipment that support those systems.
- *Auxiliary buildings.* Auxiliary buildings house support systems (e.g., the ventilation system, emergency core cooling system, laundry facilities, water treatment system, and waste treatment system). An auxiliary building may also contain the emergency diesel generators and, in some PWRs, the diesel fuel storage facility.
- *Diesel generator building.* Often a separate building houses the emergency diesel generators if they are not located in the auxiliary building.
- *Pump houses.* Various pump houses for circulating water, standby service water, or makeup water may be onsite.

Generic Facility Descriptions and Activities

- *Cooling towers.* Cooling towers are structures designed to remove excess heat from the condenser without dumping the heat directly into waterbodies (e.g., lakes or rivers). The two principal types of cooling towers are mechanical draft towers and natural draft towers. Most nuclear plants with once-through cooling do not have cooling towers. However, seven facilities with once-through cooling also have cooling towers that are used to reduce the temperature of the water before it is released to the environment.
- *Radwaste facilities.* Radioactive waste facilities may be contained in an auxiliary building or located in a separate radwaste building.
- *Ventilation stack.* Many older nuclear power plants, particularly BWRs, have ventilation stacks to discharge gaseous waste effluents and ventilation air directly to the outside. These stacks can be 90 m (300 ft) tall or higher and contain monitoring systems to ensure that radioactive gaseous discharges are below fixed release limits.
- *Switchyard and transmission lines.* Facilities typically contain a large switchyard that connects the site to the regional power distribution system.
- *Administrative, training, and security buildings.* In most cases, administrative, training, and security buildings are located outside the protected area of the plant.
- *Independent spent fuel storage installations.* An ISFSI is designed and constructed for the interim storage of spent fuel pending permanent disposal. ISFSIs are used by operating plants to add spent fuel storage capacity beyond that available in spent fuel pools.

Nuclear power plant facilities are large industrial complexes with land-use requirements generally amounting to 40 to 50 ha (100 to 125 ac) for the reactor-containment building, auxiliary buildings, cooling system structures, administration and training offices, and other facilities (e.g., switchyards, security facilities, and parking lots). Areas disturbed during construction of the power plant generally have been returned to prior uses or were ecologically restored when construction ended. Site areas range from 34 ha (84 ac) for the San Onofre plant in California to 5,700 ha (14,000 ac) for the Clinton plant in Illinois. Almost 60 percent of plant sites encompass 200 to 800 ha (500 to 2,000 ac), with 28 site areas ranging from 200 to 400 ha (500 to 1,000 ac) and an additional 12 sites encompassing 400 to 800 ha (1,000 to 2,000 ac). Larger land areas are often associated with elaborate man-made closed-cycle cooling systems that include cooling lagoons, spray canals, reservoirs, artificial lakes, and buffer areas (NRC 2013a).

Nuclear power plant sites are located in a range of political jurisdictions, including towns, townships, service districts, counties, parishes, and states. Typically, the nearest resident lives about 0.4 km (0.25 mi) from a nuclear power plant. At more than 50 percent of the sites, the population density within an 80-km (50-mi) radius is fewer than 77 persons/km² (200 persons/mi²), and at more than 80 percent of the sites, the density within 80 km (50 mi) is fewer than 193 persons/km² (500 persons/mi²). The largest population density is around the Indian Point Nuclear Generating Station in upper Westchester County, New York, which has a

population density within 80 km (50 mi) of more than 825 persons/km² (2,138 persons/mi²). Within the 80-km (50-mi) radius, State, Federal, and Native American lands are present to various extents (NRC 2013a).

The nuclear power plant structures that are used for continued storage of spent fuel, namely spent fuel pools and at-reactor ISFSIs, are described in more detail in Section 2.1.2 of this GEIS. Power plant-specific data on spent fuel pools and ISFSIs is provided in Appendix G of this GEIS. As shown in Appendix G, spent fuel pool licensed capacities at single-unit PWR power plants range from 544 assemblies at H.B. Robinson Steam Electric Plant, Unit 2, to 2,363 assemblies at the Callaway Plant and Wolf Creek Generating Station. At BWR plants, spent fuel pool capacities range from 1,803 assemblies at the Brunswick Steam Electric Generating plant to 4,608 assemblies at Fermi Unit 2.

2.1.1.2 General Description of Multiple-Unit Nuclear Power Plant Sites

During continued storage at a multiple-unit site, other onsite reactors may be in different stages of their life cycles: under construction; operating; or decommissioning. Subject to NRC regulations that ensure independence of safety systems, multiple reactors may share systems, structures, and components (e.g., a spent fuel pool). Existing nuclear power plants with shared spent fuel pools are summarized in Table 2-1. Dresden Units 2 and 3 and Comanche Peak Units 1 and 2 do not share a pool, but have two pools in one structure. Other common structures at multiple-unit sites include cooling system infrastructure, switchyards, and ISFSIs (Sailor et al. 1987).

As noted in the Decommissioning GEIS (NRC 2002a), licensees that choose to shut down one reactor at a multi-reactor site usually choose a decommissioning option that allows the shutdown reactor to be placed in a safe, stable condition (SAFSTOR) and maintained in that state until the other reactors shut down, so that all reactors at a site can be decommissioned simultaneously.⁵ In these cases, a licensee may opt to store spent fuel in the shutdown reactor's spent fuel pool until all reactors undergo decommissioning. Alternatively, the licensee may transfer some or all of the spent fuel in the shutdown reactor's spent fuel pool to spent fuel pools for the other operating reactors or to an at-reactor or away-from-reactor ISFSI, and begin some dismantlement activities in the shutdown reactor's spent fuel pool. As discussed in Chapter 1, the NRC assumes that, in compliance with current decommissioning requirements, all of a reactor's spent fuel will have been removed from the spent fuel pool within 60 years after the end of the reactor's licensed life for operation.

⁵ See Section 2.2 below for a description of the SAFSTOR option.

Table 2-1. U.S. Pressurized Water Reactors with Shared Spent Fuel Pools

Power Plant^(a)	Shared Pool Capacity Assemblies (cores)
Braidwood	2,984 (13.5)
Byron	2,984 (13.5)
Calvert Cliffs	1,830 (8.4)
D.C. Cook	3,613 (18.7)
North Anna	1,737 (11.1)
Oconee ^(b)	1,312 (7.4)
Point Beach	1,502 (12.4)
Prairie Island	1,582 (13.1)
Sequoyah	2,091 (10.8)
Surry	1,044 (6.6)
Watts Bar ^(c)	1,386 (7.2)
Zion ^(d)	3,012 (15.6)

(a) Source: Individual plant operating licenses or safety evaluation reports, www.nrc.gov.

(b) Oconee Units 1 and 2 share a pool. Unit 3 has a separate pool.

(c) Watts Bar Unit 1 will share a pool with Unit 2, which is not yet operational.

(d) Zion Units 1 and 2 were permanently shut down on February 13, 1998.

2.1.1.3 Reactor and Fuel Technologies

Several commercial reactor designs have been built and operated in the United States. As described below, the generic analysis in this GEIS is focused on past, present, and future spent fuel types that will be subject to a future NRC licensing action. These fuel types, discussed in more detail below, include: fuel types that have been used in the past and continue to be stored under an NRC license; fuel types that are presently used; and fuel types for which the characteristics are similar to fuel used today, are well understood, and may be used in the near future. See Appendix I, High-Burnup Fuel, for additional information regarding spent fuel.

Light Water Reactors

The majority of reactors that have been licensed for commercial operation in the United States, including the currently operating nuclear power plants and those under construction, are light water reactors. Light water reactors use ordinary water as coolant and a neutron moderator to initiate and control the nuclear reaction. The two light water reactor designs in use are PWRs and BWRs. There are 65 PWRs and 35 BWRs operating in the United States today.⁶ This is

⁶ The licensee for the Vermont Yankee Nuclear Power Station has informed the NRC that the plant will permanently cease operations at the end of the current operating cycle, estimated to be in the fourth calendar quarter of 2014 (Entergy 2013). Vermont Yankee is included in the current count because it is still operating.

important for the generic analysis of continued storage because these reactors all use similar fuel, which allows the NRC to generically consider the environmental impacts of continuing to store spent fuel after the licensed life for operation of a reactor.

The nuclear fuel typically used in both types of reactors is uranium enriched to a concentration of 2 to 5 percent of the uranium-235 isotope. The fuel is in the form of cylindrical uranium dioxide (UO₂) pellets, approximately 1 cm (0.4 in) in diameter and 1 to 1.5 cm (0.4 to 0.6 in) in height. The fuel pellets are stacked and sealed inside a hollow cylindrical fuel rod made of zirconium alloy. As described further below, a small amount of stainless-steel-clad fuel was used in the past and is still being stored under NRC licenses. Fuel rods are approximately 4.3 m (14 ft) long. They are bundled into fuel assemblies that generally consist of 15 × 15 or 17 × 17 rods for PWRs and 8 × 8 or 10 × 10 rods for BWRs. For PWRs, there are typically 150 to 200 fuel assemblies, containing between 179 and 264 fuel rods per assembly, loaded into the core when operating. For BWRs, there are typically between 370 and 800 fuel assemblies, containing between 62 and 96 fuel rods per assembly, loaded into the core when operating. The mass of uranium fuel in a typical light water reactor core is approximately 100 MTU.

Enrichment: *Enriching uranium increases the proportion of uranium atoms that can be “split” by fission to release energy (usually in the form of heat) that can be used to produce electricity.*

As shown in Table 2-2, fuel with stainless-steel cladding was used at five plants that are all shut down. LaCrosse was the last decommissioning plant to transfer its stainless-clad fuel from its pool into an at-reactor dry storage ISFSI in September 2012 (UxC 2013). Some of the Haddam Neck and San Onofre Unit 1 stainless-clad fuel is stored at the GEH Morris away-from-reactor ISFSI and the remainder is in at-reactor dry storage. The continued storage of this fuel is an NRC-licensed activity.

Table 2-2. Stainless-Steel-Clad Fuel at Decommissioning Plants

Plant	Discharged Stainless-Clad Assemblies ^(a)	Stored at GEH Morris ISFSI ^(b)
Haddam Neck	945 ^(c)	82
Indian Point Unit 1	160	---
LaCrosse	333	---
San Onofre Unit 1	665	270
Yankee Rowe	76	---
Total	2,179	352
Sources:		
(a) EIA 1994.		
(b) NRC 2004a.		
(c) S. Cohen & Associates, Inc. 1998.		

Generic Facility Descriptions and Activities

The amount of spent fuel accumulated at a reactor over its licensed life depends on factors such as how long the reactor operates each year, the duration of outages, spent fuel burnup, and operating lifetime. For purposes of analysis in this GEIS, the NRC assumes reactors operate with high capacity factors and short outages, which results in the generation of more spent fuel.

Spent fuel burnup describes the extent to which energy has been extracted from nuclear fuel and is one factor in how often a reactor's fuel needs to be replaced. Burnup is the actual energy released per mass of initial fuel in GWd/MTU. Spent fuel is considered to have low burnup if the burnup is less than 45 GWd/MTU. At low burnups, about one-fourth to one-third of the spent fuel assemblies are removed from the reactor and replaced every 12 to 18 months. Therefore, the amount of spent fuel discharged from a typical light water reactor operating at low burnups is about 20 MTU per year. After 80 years of reactor operation at low burnups, this amounts to about 1,600 MTU of spent fuel. A reactor could operate for 80 years if the licensee requested, and the NRC granted, two 20-year renewals of its initial 40-year operating license.

Currently, the average discharge burnup for PWRs and BWRs is approximately 48 and 43 GWd/MTU, respectively (EPRI 2012). By 2020 it is projected that the maximum discharge burnups for PWRs and BWRs will be 55 and 48 GWd/MTU, respectively (EPRI 2012). The current trend toward extended irradiation cycles and higher fuel enrichments of up to 5 weight percent uranium-235 has led to an increase of the burnup range for discharged nuclear fuel assemblies in the United States that is expected to eventually exceed 60 GWd/MTU. For plants at which higher fuel burnups are authorized, the period between outages may be extended to 24 months and the annual discharge of spent fuel reduced to about 15 MTU per year. Should a nuclear power plant operate for up to 80 years with high-burnup fuel, it would generate about 1,200 MTU of spent fuel.

For purposes of analysis in this GEIS, the NRC relies on the larger reactor lifetime amount of spent fuel discharged at low burnups (i.e., 1,600 MTU). This is because many of the environmental impacts (e.g., land use, geology and soils, and terrestrial resources) will depend upon the greater amount of space needed to store the larger amounts of spent fuel that would be generated at low burnups. In cases where high-burnup fuel is a consideration in the impact determination, this is explained in the supporting analysis. Appendix I provides further discussion on the characteristics, storage, and transportation of high-burnup uranium oxide and mixed oxide (MOX) spent fuel.

Mixed Oxide Fuel

MOX fuel is a type of nuclear reactor fuel that contains plutonium oxide mixed with either natural or depleted uranium oxide in ceramic pellet form. Using plutonium reduces the amount of enriched uranium needed to produce a controlled reaction in commercial light water reactors. MOX fuel was produced and used in the United States prior to the mid-1970s; during that time, the United States reprocessed nuclear fuel and recovered plutonium for reuse as MOX fuel in

light water reactors. MOX fuel was used at Quad Cities, San Onofre, Big Rock Point, Dresden Unit 1 and, as recently as 2005–2008, Catawba Unit 1. Catawba Unit 1 used four MOX lead test assemblies that were part of a nonproliferation project conducted by the National Nuclear Security Administration. Because the MOX fuel is substantially similar to existing uranium oxide light water reactor fuel and was, in fact, used in existing light water reactors in the United States, it is within the scope of this GEIS.

MOX fuel is not currently being produced in the United States; however, an application is pending before the NRC for Shaw AREVA MOX Services (formerly Duke COGEMA Stone & Webster) to manufacture MOX fuel at the Mixed Oxide Fuel Fabrication Facility at the Savannah River Site in South Carolina as part of the National Nuclear Security Administration's ongoing nonproliferation project. The MOX fuel proposed to be manufactured by Shaw AREVA MOX Services is a blend of plutonium dioxide, extracted from retired nuclear weapons and other sources of surplus plutonium, and depleted uranium dioxide, which is a byproduct of the uranium enrichment process. Because the MOX fuel that would be generated at the Mixed Oxide Fuel Fabrication Facility is substantially similar to existing light water reactor fuel and is, in fact, intended for use in existing light water reactors in the United States, MOX fuel from this project is within the scope of this GEIS.

Integral Pressurized Water Reactors

The NRC is preparing to review a number of integral pressurized water reactor (iPWR) designs that are currently under development. An iPWR is a small modular reactor that uses light water reactor technology. Current iPWR designs employ light water reactor technology with current design fuel and secondary loop steam generators, but also incorporate a number of advanced features and characteristics (NRC 2012). The NRC is currently engaged in preapplication activities with several applicants for light water small modular reactors.

Because the light water reactor fuel that would be used in iPWR designs is substantially similar to existing light water reactor fuel (i.e., zirconium-clad, low-enriched uranium oxide pellets in square fuel rod arrays), it is within the scope of this GEIS.

Other Commercial Reactor and Fuel Designs

In addition to light water reactors, two other reactor technologies are sufficiently well developed to be deployed for use as commercial nuclear power plants: the high-temperature gas-cooled reactor and the liquid metal fast reactor. As described in more detail below, spent fuel generated by these technologies is not within the scope of the analysis in this GEIS, with the exception of high-temperature gas reactor fuel stored in the Fort Saint Vrain ISFSI, because neither technology is in commercial use or under development in the United States at this time.

Generic Facility Descriptions and Activities

High-Temperature Gas-Cooled Reactors

A high-temperature gas-cooled reactor is a type of nuclear fission reactor that typically operates at a very high temperature, is graphite-moderated, and uses an inert gas such as helium as its primary coolant. Fuel may be loaded in the core in a prismatic or pebble bed design. In the United States, there have been two high-temperature gas-cooled reactors built and commercially operated: Fort Saint Vrain and Peach Bottom Unit 1. Fort Saint Vrain has been decommissioned, and Peach Bottom Unit 1 is in the process of decommissioning. The Fort Saint Vrain spent fuel continues to be stored at an NRC-licensed ISFSI in Platteville, Colorado, and is within the scope of this GEIS.⁷ Peach Bottom Unit 1 fuel is under Federal government control at the Idaho National Laboratory and is not within the scope of this GEIS because it is no longer regulated by the NRC.

The NRC was participating in preapplication reviews of the DOE's Next Generation Nuclear Plant. The Next Generation Nuclear Plant would use nuclear fuel comprised of tristructural-isotropic-coated fuel particles contained in either fuel pebbles or prismatic fuel assemblies. The uranium oxycarbide kernels in each particle would be encapsulated in successive layers of silicon carbide and pyrolytic carbon.

Because this fuel type has not completed fuel qualification testing, it is not yet a commercially viable technology. If this technology should become viable and the NRC is asked to review one or more license applications for a high-temperature gas-cooled reactor facility, then the environmental impacts of continued storage of that spent fuel will be considered in individual licensing proceedings unless the NRC updates the GEIS and corresponding rule to include the environmental impacts of storing this type of fuel after a reactor's licensed life for operation.

Liquid Metal Fast Reactor

Liquid metal fast reactors use a molten metal (e.g., sodium) as their primary coolant. Fuel for a liquid metal fast reactor varies by concept, but typically consists of a mix of uranium and zirconium or a mix of uranium, plutonium, and zirconium. In the United States, Enrico Fermi Unit 1 was a liquid-sodium-cooled fast reactor that operated between 1963 and 1972. Fermi Unit 1 is in the process of decommissioning and all spent fuel has been removed from the site and is now the responsibility of the DOE.

The NRC is engaged in preliminary preapplication discussions with the designers of three liquid metal fast reactors—Toshiba Corporation's Super-Safe, Small, and Simple design; General Electric Hitachi's Power Reactor Innovative Small Module design; and Gen4 Energy's Gen4

⁷ The NRC renewed the license for the Fort St. Vrain ISFSI in May 2011, after completing an environmental assessment and finding of no significant impact (76 FR 30399).

Module design. The fuel types in these designs range from a mix of uranium-zirconium or uranium-plutonium-zirconium metal alloys to stainless-steel-clad uranium nitride.

These fuel types have not completed fuel qualification testing and are not yet commercially viable technologies. If these technologies should become viable and the NRC is asked to review one or more license applications for a liquid metal fast reactor facility, then the environmental impacts of continued storage of that spent fuel will be considered in individual licensing proceedings unless the NRC updates the GEIS and corresponding rule to include the environmental impacts of storing this type of fuel after a reactor's licensed life for operation.

2.1.2 Onsite Spent Fuel Storage and Handling

As of the end of 2011, the amount of commercial spent fuel in storage at commercial nuclear power plants was an estimated 67,500 MTU. The amount of spent fuel in storage at commercial nuclear power plants is expected to increase at a rate of approximately 2,000 MTU per year (CRS 2012).

Licensees have designed spent fuel pools to temporarily store spent fuel in pools of continuously circulating water that cool the spent fuel assemblies and provide shielding from radiation. When the nuclear power industry designed the current fleet of operating nuclear power plants, it expected that, after a few years, the plant operators would transport spent fuel to one or more reprocessing plants. However, as a result of historic decision-making on reprocessing⁸ no commercial spent fuel reprocessing facilities are currently operating or planned in the United States (Copinger et al. 2012).

2.1.2.1 Spent Fuel Pools

Spent fuel pools are designed to store and cool spent fuel following its removal from a reactor. Spent fuel pools are massive and durable structures constructed from reinforced-concrete walls and slabs that vary between 0.7 and 3 m (2 and 10 ft) thick. Typically, spent fuel pools are at least 12 m (40 ft) deep, allowing the spent fuel to be covered by at least 6 m (20 ft) of water, which provides adequate shielding from the radiation for anyone near the pool. All spent fuel pools currently in operation are lined with stainless-steel liners that vary in thickness from 6 to 13 mm (0.25 to 0.5 in.) (Copinger et al. 2012). Further, all spent fuel pools have either a leak-detection system or administrative controls to monitor the spent fuel pool liner. Typically, leak-detection systems are made up of several individually monitored channels or are designed

⁸ In furtherance of anti-proliferation policies, the Federal government declared a moratorium on reprocessing spent fuel in 1976. This moratorium was lifted in 1981, but in 1993, President Clinton issued a policy statement that the United States does not encourage civil use of plutonium, including reprocessing. In 2001, President Bush's National Energy Policy encouraged research into reprocessing technologies. Currently, there is no Federal moratorium on reprocessing.

Generic Facility Descriptions and Activities

so that leaked water empties into monitored drains. Leaked water is directed to a sump, liquid radioactive waste treatment system, or other cleanup or collection system.

Reactor designers originally anticipated that spent fuel would be stored for less than 1 year before being shipped to a reprocessing plant for separation of the fissile isotopes. For this reason, currently operating reactors originally had storage capacity for one full core plus one or two additional discharged batches of spent fuel. When the United States abandoned spent fuel reprocessing and spent fuel pools began to fill up, licensees expanded fuel storage capacity by replacing the original storage racks with higher density fuel racks. Licensees achieved the higher density by taking into account in their safety assessments the neutron-absorbing characteristics of the stainless-steel structure of the storage racks and incorporating plates or sheets containing a neutron absorber material for reactivity control (EPRI 1988). As a result, a typical spent fuel pool at a light water reactor can hold the equivalent of about seven reactor core loads, or about 700 MTU (see Appendix G).

On this basis, a typical spent fuel pool has about 700 MTU storage capacity that reaches its licensed capacity limit in about 35 years into licensed life for operation of a reactor. At that point, some of the spent fuel would need to be removed from the spent fuel pool and transferred to a dry cask storage system at either an at-reactor or away-from-reactor ISFSI.

Spent fuel pools are constructed with the reactor, not during continued storage. Therefore, the cost of building a spent fuel pool facility is not included in this GEIS. However, operating the spent fuel pool is a continued storage activity, and those costs are presented in Section 2.2.1.2.

Two events have resulted in changes to NRC requirements for physical security and the safe operation of spent fuel pools. The first was the terrorist attacks on September 11, 2001, after which the NRC ordered all operating nuclear power plants to immediately implement compensatory security measures. In addition, the NRC issued Orders to decommissioning reactor licensees that imposed additional security measures associated with access authorization, fitness for duty, and behavior observation. In 2009, the NRC completed a rulemaking that codified generally applicable security requirements for operating power plants (74 FR 13926).

Second, in response to the March 11, 2011 severe earthquake and subsequent tsunami that resulted in extensive damage to the six nuclear power reactors at Japan's Fukushima Dai-ichi site, the NRC established a task force of senior agency experts (Near-Term Task Force). On July 12, 2011, the Near-Term Task Force issued its report, which concluded that there was no imminent risk from continued operation and licensing activities (NRC 2011a). Based on its analysis, the Near-Term Task Force made 12 overarching recommendations for changes to ensure the continued safety of U.S. nuclear power plants.

Several of these recommendations addressed spent fuel pool integrity and assurance of adequate makeup water in the event of a serious accident. In response to the Near-Term Task Force's recommendations, the NRC issued multiple Orders and a request for information to all of its operating power reactor licensees and holders of construction permits in active or deferred status on March 12, 2012. The Orders addressed (1) mitigating strategies for beyond-design basis external events and (2) reliable spent fuel pool instrumentation. In addition, the NRC issued the request for information to assist the agency in reevaluating seismic and flooding hazards at operating reactor sites and determining whether appropriate staffing and communication can be relied upon to coordinate event response during a prolonged station blackout event, as was experienced at Fukushima Dai-ichi. The NRC will use the information collected to determine whether to update the design basis and systems, structures, and components important to safety, including spent fuel pools. However, because the NRC has not yet decided whether any license needs to be modified, suspended, or revoked, for purposes of analysis in this GEIS, the NRC assumes that the related existing regulatory framework remains unchanged. Further, the NRC has initiated a rulemaking to address a condition known as station blackout, a situation that involves the loss of all onsite and offsite alternating current power at a nuclear power plant. The advance notice of proposed rulemaking was published on March 20, 2012 (77 FR 16175), and the draft regulatory basis was published on April 10, 2013 (78 FR 21275). Among other issues being considered as part of the rulemaking, the NRC is evaluating whether to require additional equipment (e.g., backup power supplies and instrumentation) to ensure the safety of spent fuel pools. Current information regarding the status of this proposed rule can be found on the regulations.gov website (www.regulations.gov) under Docket ID NRC-2011-0299.

2.1.2.2 At-Reactor Independent Spent Fuel Storage Installations

Spent fuel pools, as discussed above, have limited capacity to store a reactor's spent fuel. As noted, a typical spent fuel pool has a storage capacity of about 700 MTU that reaches its licensed capacity limit about 35 years into licensed life for operation of a reactor. At that point, the licensee needs a dry cask storage system to store older fuel that has cooled sufficiently and can be removed safely from the pool. These dry cask storage systems are located in ISFSIs at reactor sites and are licensed by the NRC. Dry cask storage systems shield people and the environment from radiation and keeps the spent fuel dry and nonreactive (NRC 2013b).

There are many different dry cask storage systems, but most fall into two main categories based on how they are loaded. The first is the bare fuel, or direct-load, casks, in which spent fuel is loaded directly into a basket that is integrated into the cask. Bare fuel casks, which tend to be all metal construction, are generally bolted closed. The second is a canister-based system in which spent fuel is loaded into a basket inside a cylinder called a canister. The canister is usually loaded while inside a transfer cask, then welded and transferred vertically into either a concrete or metal storage overpack or horizontally into a concrete storage module (e.g., NUHOMS) (Hanson et al. 2012). Typical dry cask storage systems are shown in Figure 2-1.

At some nuclear reactors across the country, spent fuel is kept onsite, typically above ground, in systems basically similar to the ones shown here.

I *Once the spent fuel has sufficiently cooled, it is loaded into special canisters that are designed to hold nuclear fuel assemblies. Water and air are removed. The canister is filled with inert gas, welded shut, and rigorously tested for leaks. It is then placed in a cask for storage or transportation. The NRC has approved the storage of up to 40 PWR assemblies and up to 68 BWR assemblies in each canister. The dry casks are then loaded onto concrete pads.*



2 *The canisters can also be stored in above ground concrete bunkers, each of which is about the size of a one-car garage.*

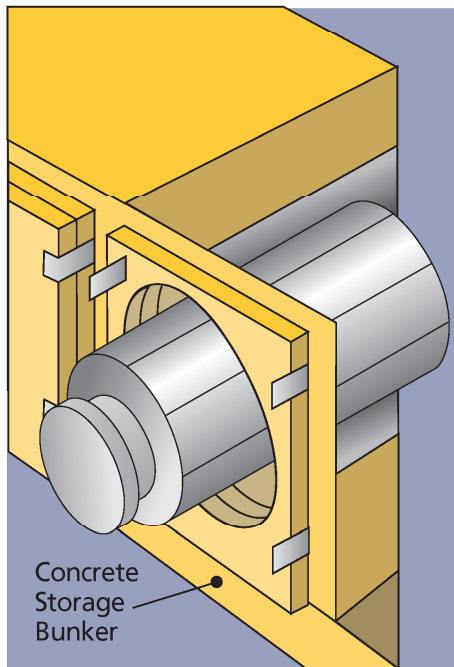

Figure 2-1. Dry Storage of Spent Fuel (Source: NRC 2013b)

Dry cask storage systems are licensed by the NRC for storage only or for storage and transportation. Storage-only casks are not certified for transportation under 10 CFR Part 71, "Packaging and Transportation of Radioactive Material." Casks and canisters licensed for both storage and transportation are generally referred to as dual-purpose casks and dual-purpose canisters. Some vendors refer to their dual-purpose casks or canisters as "multipurpose" canisters, which implies that it would be suitable for storage, transportation, and disposal. However, in the absence of a repository program, there are no specifications for disposal canisters and, therefore, no dual-purpose casks or canisters have been certified as multipurpose (Hanson et al. 2012).

As of June 2014, there were operational ISFSIs at 64 sites. One operational ISFSI, at the GEH Morris site, is a wet storage facility. The remaining ISFSIs store spent fuel in over 1,900 loaded dry casks. Two licenses have been issued for ISFSIs, the PFS facility and the Idaho Spent Fuel Facility, neither of which have been constructed. Figure 2-2 shows the locations of U.S. ISFSIs. Information on ISFSIs is presented in Appendix G of this GEIS.

The NRC authorizes construction and operation of ISFSIs by general and specific licenses. A general license is created by regulation and confers the right upon the general licensee to proceed with the licensed activity without further review or approval by the NRC. A specific license, by contrast, requires an application to perform the licensed activity and NRC review and approval to proceed with the licensed activity.

As these concepts apply to ISFSIs, every nuclear power reactor licensee, by virtue of the general license in 10 CFR Part 72, Subpart K, is authorized to store spent fuel in casks whose design has been approved by the NRC. Licensees must evaluate the safety of using the approved casks at the ISFSI for site-specific conditions, including man-made and natural hazards, and must conform to all requirements under Subpart K for use of the approved design. In addition, licensees must review their programs for operating the reactor (e.g., physical security, radiation protection, and emergency planning) to determine if those programs are affected by use of the casks and, if so, to seek approval from the NRC for any necessary changes to those programs.

Further, a reactor licensee can seek a specific license to construct and operate an ISFSI, which requires NRC's review of the safety, environmental, and physical security aspects of the proposed facility and the licensee's financial qualifications. If the NRC concludes the proposed ISFSI meets licensing criteria, then the NRC grants the specific license. This license contains various conditions (e.g., leak testing and monitoring) and specifies the quantity and type of material the licensee is authorized to store at the site. A specific license runs for a term of up to 40 years and may be renewed in accordance with all applicable requirements.

Licensed and Operating Independent Spent Fuel Storage Installations by State

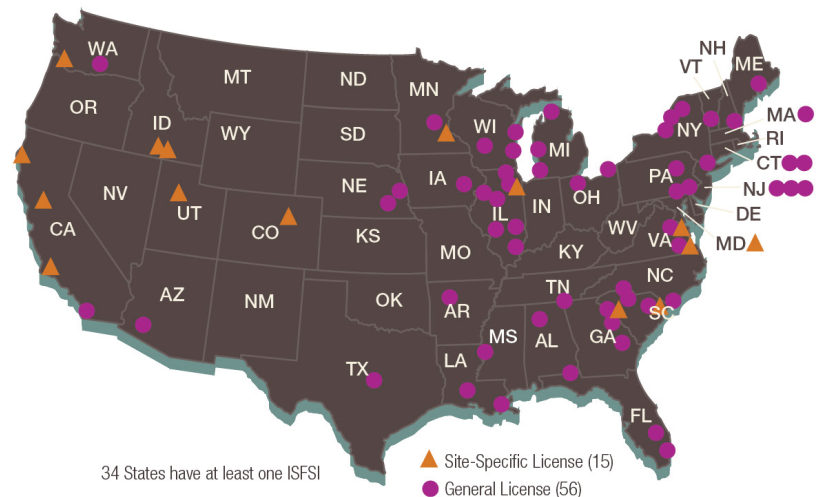

ALABAMA	ILLINOIS	MISSISSIPPI	PENNSYLVANIA
● Browns Ferry	● Braidwood	● Grand Gulf	● Limerick
● Farley	● Byron	NEBRASKA	● Susquehanna
ARIZONA	▲ GE Morris (Wet)	● Cooper	● Peach Bottom
● Palo Verde	● Dresden	● Ft. Calhoun	SOUTH CAROLINA
ARKANSAS	● La Salle	NEW HAMPSHIRE	● ▲ Oconee
● Arkansas Nuclear	● Quad Cities	● Seabrook	● ▲ Robinson
CALIFORNIA	● Zion	NEW JERSEY	● Catawba
▲ Diablo Canyon	IOWA	● Hope Creek	TENNESSEE
▲ Rancho Seco	● Duane Arnold	● Salem	● Sequoyah
● San Onofre	LOUISIANA	● Oyster Creek	TEXAS
▲ Humboldt Bay	● River Bend	NEW YORK	● Comanche Peak
COLORADO	● Waterford	● Indian Point	UTAH
▲ Fort St. Vrain	MAINE	● FitzPatrick	▲ Private Fuel Storage
CONNECTICUT	● Maine Yankee	● Ginna	VERMONT
● Haddam Neck	MARYLAND	● Nine Mile Point	● Vermont Yankee
● Millstone	▲ Calvert Cliffs	NORTH CAROLINA	VIRGINIA
FLORIDA	MASSACHUSETTS	● Brunswick	● ▲ Surry
● St. Lucie	● Yankee Rowe	● McGuire	● ▲ North Anna
● Turkey Point	MICHIGAN	OHIO	WASHINGTON
GEORGIA	● Big Rock Point	● Davis-Besse	● Columbia
● Hatch	● Palisades	● Perry	WISCONSIN
● Vogtle	● Cook	OREGON	● Point Beach
IDAHO	MINNESOTA	▲ Trojan	● Kewaunee
▲ DOE: TMI-2 (Fuel Debris)	● Monticello		● LaCrosse
▲ Idaho Spent Fuel Facility	▲ Prairie Island		

Data as of June 1, 2014

Figure 2-2. Licensed/Operating ISFSIs by State (Source: NRC 2014)

As described in more detail in Section 2.2.1, nuclear power plant licensees will undertake major decommissioning activities during the 60 years following permanent cessation of reactor operations. During major decommissioning activities, the licensees will transfer spent fuel from spent fuel pools to either an at-reactor or away-from-reactor ISFSI. When decommissioning of the reactor and related facilities is completed and the at-reactor ISFSI is the only spent fuel storage structure left onsite, the facility is referred to as an “ISFSI-only site.” Existing ISFSI-only sites include Big Rock Point, Haddam Neck, Fort St. Vrain, Maine Yankee, Rancho Seco, Trojan, and Yankee Rowe.

The NRC requires licensees to develop spent fuel management plans that include specific consideration of a plan for removal of spent fuel stored under a general license, and spent fuel management before decommissioning systems and components needed for moving, unloading, and shipping spent fuel (10 CFR 50.54(bb) and 72.218).⁹

Construction of a replacement at-reactor ISFSI is a continued storage activity in the long-term and indefinite timeframes. The Electric Power Research Institute (EPRI) developed a formula for estimating the cost to design, license, and construct a dry cask storage facility (EPRI 2012). EPRI’s cost estimate is based in part on the number of casks at the facility. For cost estimates in this GEIS, the NRC uses the EPRI value of 10 MTU per cask (EPRI 2009), which translates to 160 casks for a 1,600 MTU at-reactor ISFSI. Based on EPRI’s formula and its 2012 data, a single 1,600 MTU storage capacity facility costs \$107,000,000 (\$107M) to design, license, and construct.

Following the terrorist attacks on September 11, 2001, the NRC issued Orders to ISFSI licensees to require certain compensatory measures. For example, on May 23, 2002, the NRC issued an Order to the GEH Morris wet storage ISFSI (NRC 2002b). On October 16, 2002, the NRC also issued Orders to specifically licensed and generally licensed dry storage ISFSIs (including those with near-term plans to store spent fuel in an ISFSI under a general license). The details of these Orders are withheld from the public for security reasons.

In addition to NRC licensing requirements, licensees may also be subject to individual State requirements. For example, the State of Minnesota Public Utilities Commission requires an applicant to receive a “certificate of need” prior to constructing an ISFSI.

Example of At-Reactor ISFSIs

Dry cask storage systems in use in the United States are summarized in Appendix G. Two common systems are described below.

⁹ The regulations reference “irradiated-fuel-management plans.” For the purposes of this discussion there is no difference between irradiated fuel and spent fuel.

Generic Facility Descriptions and Activities

A common vertical dry cask storage system currently in use in at-reactor ISFSIs is Holtec International's HI-STORM 100. The HI-STORM cylindrical overpack is stored on an ISFSI pad with its longitudinal axis in a vertical orientation and could contain, for example, a single Holtec MPC-32 multipurpose canister, which can hold up to 32 PWR fuel assemblies. Compatible canisters are also available for BWR spent fuel. As a result, dry storage of the entire 1,600 MTU of spent fuel generated by a typical reactor, assuming all spent fuel is eventually transferred from the spent fuel pool, would require about 100 casks. Each storage cask is about 3.4 m (11 ft) wide and 6.1 m (20 ft) tall. The layout of casks on an ISFSI pad is guided by operational considerations at each site. However, a nominal layout involves casks separated by about 4.5 m (15 ft). Therefore, a typical ISFSI pad with 100 casks located inside a protected area common to the power plant, and arranged as 10 rows of 10 casks each, would cover about 46 × 46 m (150 × 150 ft) for a total area of about 0.2 ha (0.5 ac) (Holtec 2000). For purposes of analysis in this GEIS, the NRC assumes that an ISFSI of sufficient size to hold all spent fuel generated by a reactor is constructed during the reactor's licensed life for operation.

A common horizontal dry cask storage system currently in use in at-reactor ISFSIs is available from Transnuclear, Inc., a wholly-owned subsidiary of AREVA North America. The NUHOMS horizontal cask system uses dry shielded canisters that are placed in concrete horizontal storage modules (HSMs). Among the compatible NRC-approved canister designs is the NUHOMS-61BT dry shielded canister. This canister, for example, can hold 61 BWR fuel assemblies. Canisters are also available for PWR spent fuel. For a BWR, the HSM is about 6.0 m (20 ft) long, 4.6 m (15 ft) high and 2.9 m (9.7 ft) wide. As a result, dry storage of 1,600 MTU of spent fuel generated by a generic BWR, assuming all spent fuel is eventually transferred from the spent fuel pool to an at-reactor ISFSI, would require about 150 HSMs. If HSMs were installed in rows and placed back-to-back in 2 × 10 arrays, an ISFSI with 150 HSMs would require about 7 double module rows and a single module row of 10 HSMs. Allowing for a 6-m- (20-ft-) wide concrete approach slab on the entrance side of each HSM, a 150 HSM ISFSI site would be about 60 m (200 ft) wide and 220 m (720 ft) long. Therefore, the total area of the horizontal ISFSI, including the protected area, would be about 1.3 ha (3.6 ac).

2.1.3 Away-from-Reactor ISFSIs

Existing away-from-reactor ISFSIs include the GEH Morris wet storage facility in Morris, Illinois, and the DOE's Three Mile Island, Unit 2 Fuel Debris ISFSI at the Idaho National Engineering Laboratory. Further, the NRC has issued a license to PFS for an away-from-reactor ISFSI, which would have been located on the reservation of the Skull Valley Band of Goshute Indians (NRC 2004b).

A future away-from-reactor ISFSI could accept spent fuel from one or more nuclear power plants. For purposes of this GEIS, the NRC assumes that the nuclear power industry could develop an away-from-reactor ISFSI that would store up to 40,000 MTU of spent fuel from various nuclear power plant sites using existing technologies.

Construction of away-from-reactor ISFSIs is a continued storage activity for the short-term, long-term, and indefinite timeframes. For an away-from-reactor ISFSI, the initial construction cost is different than subsequent replacement construction costs because of transportation. For spent fuel transportation, continued storage only addresses the one-time transfer of spent fuel from the at-reactor ISFSI to an away-from reactor ISFSI. Therefore, transportation capital costs are only included in the initial construction of an away-from-reactor ISFSI. For continued storage, subsequent replacement of an away-from-reactor ISFSI excludes transportation capital costs because the spent fuel is already located at the site. EPRI estimated the costs of constructing a

40,000 MTU ISFSI (EPRI 2009). The EPRI estimate is based in part on the number of casks at the facility. For cost estimates in this GEIS, the NRC uses the EPRI value of 10 MTU per cask (EPRI 2009) which translates to 4,000 casks for a 40,000 MTU away-from-reactor ISFSI. Based on 2009 data from EPRI (EPRI 2009), the NRC estimates initial construction costs for a 40,000 MTU away-from-reactor interim storage facility at \$680M, which includes \$74.2M for start-up costs, \$141M for facility capital costs, and \$465M for transportation capital costs. Excluding the transportation capital cost reduces the price for building a replacement away-from-reactor ISFSI at that location (i.e., subsequent replacement construction cost) to \$215M. Activity costs associated with transportation are described in GEIS Section 2.2.1.4.

Spent fuel would be moved from operating or decommissioning reactor sites, or ISFSI-only sites, to an away-from-reactor ISFSI or ISFSIs, and then from the away-from-reactor ISFSI to one or more permanent repositories. Aside from the existing GEH Morris wet storage facility, and for the purposes of the analysis in this GEIS, the NRC assumes that, in the future, a portion of the nuclear power industry's spent fuel would be stored in one or more dry cask storage systems at an away-from-reactor ISFSI.

In 2006, the NRC granted a license to PFS, to construct and operate an away-from-reactor ISFSI in Skull Valley, Utah. PFS, a consortium of eight nuclear power utilities, proposed to construct the site on the reservation of the Skull Valley Band of Goshute Indians, about 80 km (50 mi) southwest of Salt Lake City, Utah. The PFS facility was intended for temporary aboveground storage, using the Holtec HI-STORM dual-purpose canister-based cask system, of up to 40,000 MTU of spent fuel from U.S. commercial nuclear power plants. PFS proposed to build the ISFSI on a 330-ha (820-ac) site leased from the Skull Valley Band of Goshute Indians. The site would be located in the northwest corner of the reservation approximately 6 km (3.5 mi)

Start-up costs include the design, engineering, and licensing costs associated with constructing a storage facility.

Storage facility capital costs include the construction, material, and equipment costs for the storage pads and the various support buildings.

Transportation capital costs include infrastructure (e.g., rail spurs), transportation equipment (e.g., rail locomotives and cars), and transportation casks and associated equipment.

Generic Facility Descriptions and Activities

from the Skull Valley Band's village. The proposed PFS ISFSI has not been constructed. Despite the PFS facility not having been constructed, issuance of the PFS license supports the assumption in this GEIS that an away-from-reactor ISFSI is feasible and that the NRC can license an away-from-reactor storage facility. Thus, the NRC's analysis of construction, operation, and decommissioning activities and impacts for an away-from-reactor ISFSI in NUREG-1714 are reflected in this GEIS (NRC 2001).

Consolidated Storage

On January 29, 2010, the President of the United States directed the Secretary of Energy to establish a "Blue Ribbon Commission on America's Nuclear Future." The Blue Ribbon Commission was tasked with conducting a comprehensive review of policies for managing the back end of the nuclear fuel cycle and recommending a new strategy. The Blue Ribbon Commission issued its findings and conclusions in January 2012 (BRC 2012). Among the findings and conclusions related to continued storage of spent fuel was a strategy for prompt efforts to develop one or more consolidated storage facilities.

In January 2013, DOE published its response to the Blue Ribbon Commission recommendations titled, *Strategy for the Management and Disposal of Used Nuclear Fuel and High-Level Radioactive Waste* (DOE 2013). This strategy implements a program over the next 10 years that, with congressional authorization, will:

- site, design, construct, license, and begin operation of a pilot interim storage facility by 2021 with an initial focus on accepting spent fuel from shutdown reactor sites,
- advance toward the siting and licensing of a larger interim storage facility to be available by 2025 with sufficient capacity to provide flexibility in the waste-management system and allow for acceptance of enough spent fuel to reduce expected government liabilities, and
- make demonstrable progress on the siting and characterization of repository sites to facilitate the availability of a geologic repository by 2048.

The Federal government's support for interim storage supports the NRC's decision to consider this type of facility as one of the reasonably foreseeable interim solutions for spent fuel storage pending ultimate disposal at a repository.

2.1.4 Dry Transfer System

Although there are no dry transfer systems (DTSs) at U.S. nuclear power plant sites today, the potential need for a DTS, or facility with equivalent capability, to enable retrieval of spent fuel from dry casks for inspection or repackaging will increase as the duration and quantity of fuel in dry storage increases. A DTS would enhance management of spent fuel inspection and repackaging at all ISFSI sites and provide additional flexibility at all dry storage sites by enabling

repackaging without the need to return the spent fuel to a pool. A DTS would also help reduce risks associated with unplanned events or unforeseen conditions and facilitate storage reconfiguration to meet future storage, transport, or disposal requirements (Carlsen and Raap 2012).

Several DTS designs and related concepts have been put forward over the past few decades. Among these designs is a design developed by Transnuclear, Inc. in the early 1990s under a cooperative agreement between DOE and EPRI. Although the conceptual design was based on transferring spent fuel from a 30-ton 4-assembly source cask to a 125-ton receiving cask, the DTS could be adapted to be suitable for any two casks (Carlsen and Raap 2012).

On September 30, 1996, the DOE submitted to the NRC for review a topical safety analysis report on the Transnuclear-EPRI DTS design (DOE 1996). In November 2000, the NRC issued an assessment report in which it found the DTS concept has merit. The NRC's assessment was based on the DTS meeting the applicable requirements of 10 CFR Part 72 for spent fuel storage and handling and 10 CFR Part 20 for radiation protection. However, the DOE has not yet requested a Part 72 license for the DTS (NRC 2000).

Construction of a DTS is considered a continued storage activity in the long-term and indefinite timeframes. Based on EPRI data (EPRI 1995), the NRC estimates a construction cost of \$8.58M for the development of a DTS to handle bare spent fuel that could accommodate repackaging, as needed, to replace casks. The NRC assumed that estimated construction costs for the DTS are the same for both the at-reactor and away-from-reactor facilities.

The reference DTS considered in this GEIS is a two-level concrete and steel structure with an attached single-level weather-resistant preengineered steel building. The concrete and steel structure provides both confinement and shielding during fuel transfer operations. The DTS was designed to enable loading of one receiving cask in 10 24-hour days and unloading one source cask in one 24-hour day.

The key facility parameters and characteristics described in the September 30, 1996, topical safety analysis report are summarized below.

The reference DTS is a reinforced-concrete rectangular box structure with internal floor dimensions of about 8 × 5.5 m (26 × 18 ft) and about 14 m (47 ft) tall. The system also includes an attached, prefabricated, aluminum Butler-type building referred to as the preparation area with dimensions of about 11.6 × 7.6 m (38 × 25 ft) wide and 11.6 m (38 ft) tall. The basemat for the facility measures 14.9 × 21.9 m (49 × 72 ft), and the security zone would be about 76 × 91 m (250 × 300 ft) (i.e., less than 0.7 ha [2 ac]).

As shown in Figure 2-3, the preparation area is located at ground level of the DTS. The lower access area is next to the preparation area and directly below the transfer confinement area.

Generic Facility Descriptions and Activities

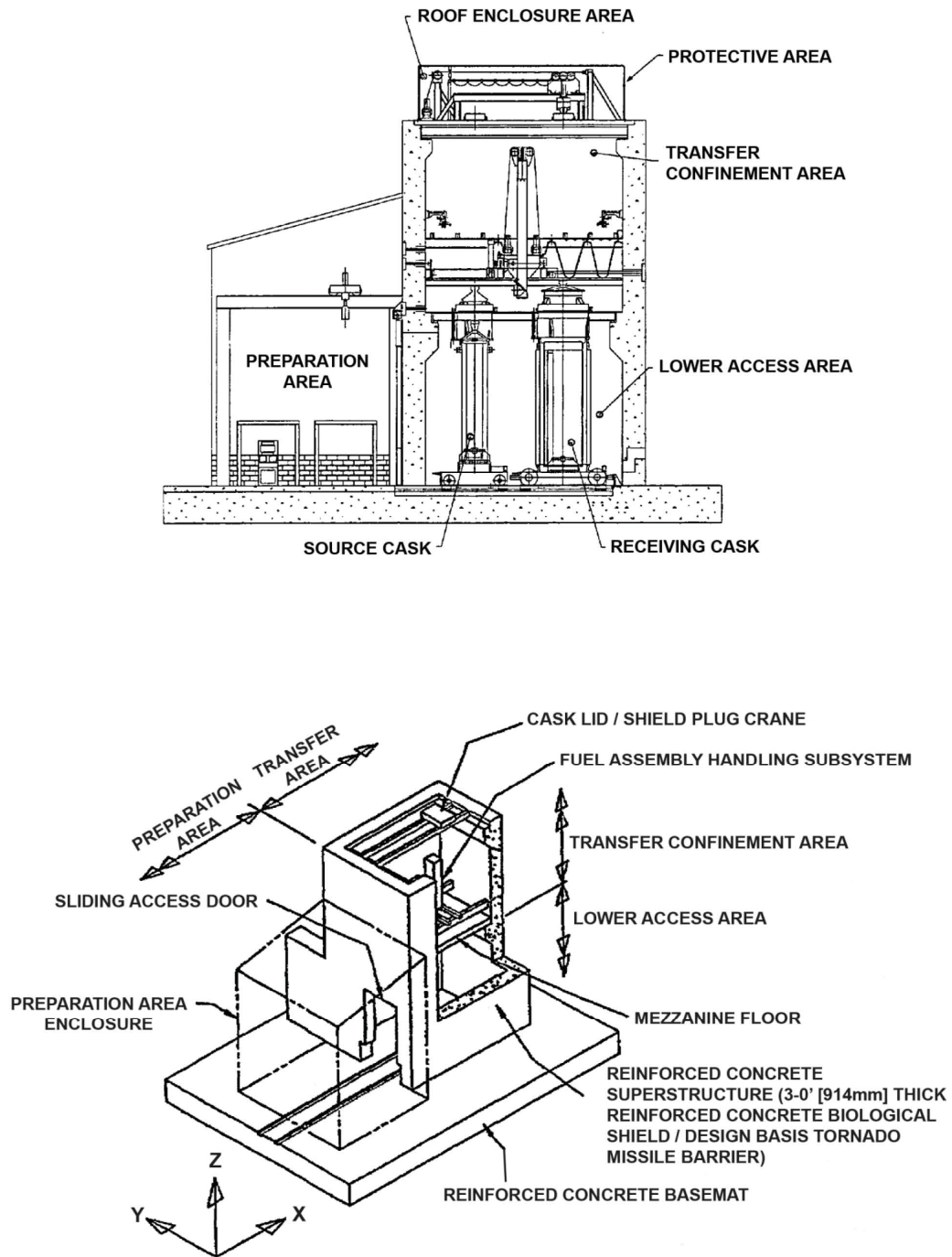

Figure 2-3. Conceptual Sketches of a Dry Transfer System (DOE 1996)

The lower access area provides shielding, confinement, and positioning for the open source and receiving casks during spent fuel transfers. An 18- to 23-cm (7- to 9-in.)-thick steel sliding door separates the lower access area from the preparation area. The transfer confinement area is the upper level of the DTS, directly above the lower access area. The transfer confinement area provides the physical confinement boundary and radiation shielding between spent fuel and the environment.

Transnuclear-EPRI found that radioactive waste generation from dry transfer activities could not be readily quantified, as it depends strongly on reactor-specific conditions, primarily the crud levels on the fuel assemblies. Table 6.1-1 of the topical safety analysis report (DOE 1996) showed the expected waste sources, including decontamination wastes, spalled material in a crud catcher, and prefilters and high-efficiency particulate air filters used in the heating ventilation and air conditioning system. Other wastes considered included mechanical lubricants and precipitation runoff. The DTS does not rely on water-supply lines. Water is brought to the facility in bottles and used for general purpose cleaning only.

The reference DTS, if licensed, would operate under the radiological protection requirements of 10 CFR Part 20, "Standards for Protection against Radiation." Occupational doses for various tasks performed in the DTS are provided in Table 7.4-1 of the topical safety analysis report (DOE 1996). Total estimated occupational doses from loading a single cask are about 0.5 person-rem.

Maximum offsite doses reported in Table 7.6-1 of the topical safety analysis report were estimated to range from 44 mrem per year at 100 m to 2 mrem per year at 500 m.

As with other facilities licensed under 10 CFR Part 72, the design events identified in ANSI/ANS 57.9 (ANSI/ANS 1992) form the basis for the accident analyses performed for the DTS. The bounding accident results for a distance of 100 m are a stuck fuel assembly (47 mrem) and a loss-of-confinement barrier (721 mrem).

This GEIS considers the environmental impacts of constructing a reference DTS to provide a complete picture of the environmental impacts of continued storage. This GEIS does not license or approve construction or operation of a DTS. A separate licensing action would be necessary before a licensee may construct and operate a site-specific DTS.

For the purposes of analysis in this GEIS, the NRC relies primarily on the facility description of the Transnuclear-EPRI DTS described above. However, for some impact assessments in this GEIS, the NRC has drawn from the *Environmental Impact Statement for the Proposed Idaho Spent Fuel Facility at the Idaho National Engineering and Environmental Laboratory in Butte County, Idaho* (NRC 2004b). The NRC licensed the Idaho Spent Fuel Facility in November 2004, but DOE has not constructed the facility. However, the proposed facility has the capability to handle bare spent fuel for the purposes of repackaging and storing spent fuel from

Peach Bottom Unit 1; the Shippingport Atomic Power Station; and various training, research, and isotope reactors built by General Atomics. Because the Idaho Spent Fuel Facility, like the DTS, includes design features that allow bare fuel-handling operations to repackage spent fuel from DOE transfer casks to new storage containers, the NRC has concluded that some environmental impacts of the facility would be comparable to those of a DTS.

2.2 Generic Activity Descriptions

As described in Chapter 1, this GEIS analyzes environmental impacts of the continued storage of spent fuel in terms of three storage timeframes: short-term, long-term, and indefinite storage. As described below, the activities at spent fuel storage facilities during the short-term timeframe coincide with nuclear power plant decommissioning activities. By the beginning of the long-term timeframe, reactor licensees will have removed all spent fuel from the spent fuel pool and decommissioned all remaining nuclear power plant structures. At that point, all spent fuel will be stored in either an at-reactor or away-from-reactor ISFSI. During the long-term storage timeframe, the NRC has conservatively assumed for the purpose of analysis in this GEIS that the need will arise for the transfer of spent fuel assemblies from aged dry cask storage systems to newer systems of the same or newer design. In addition, the NRC assumes that storage pads and modules would need to be replaced periodically. Section 1.8.2 identifies the continued storage activities for which the NRC evaluated the environmental impacts in this GEIS. This section provides the costs for those activities, as well as costs for transporting spent fuel to an away-from-reactor ISFSI during continued storage; the environmental impacts of transporting spent fuel to an away-from-reactor ISFSI are analyzed in Chapter 5.

2.2.1 Short-Term Storage Activities

As depicted in the generic timeline in Figure 2-4, after about 35 years of operation at low fuel burnups, or about 46 years of high-burnup operation, the spent fuel pool at a typical reactor reaches capacity and spent fuel must be removed from the pool to ensure full core offload capability. The inventory of spent fuel that exceeds spent fuel pool capacity may be transferred to dry cask storage at an at-reactor or away-from-reactor ISFSI. This GEIS focuses on the activities and impacts associated with continued storage in a spent fuel pool and dry cask. This section explains the activities that occur during short-term storage:

- decommissioning of the plant systems, structures, and components not required for continued storage of spent fuel,
- routine maintenance of the pool and ISFSI, and
- transfer of spent fuel from the pool to the at-reactor or away-from-reactor ISFSI.

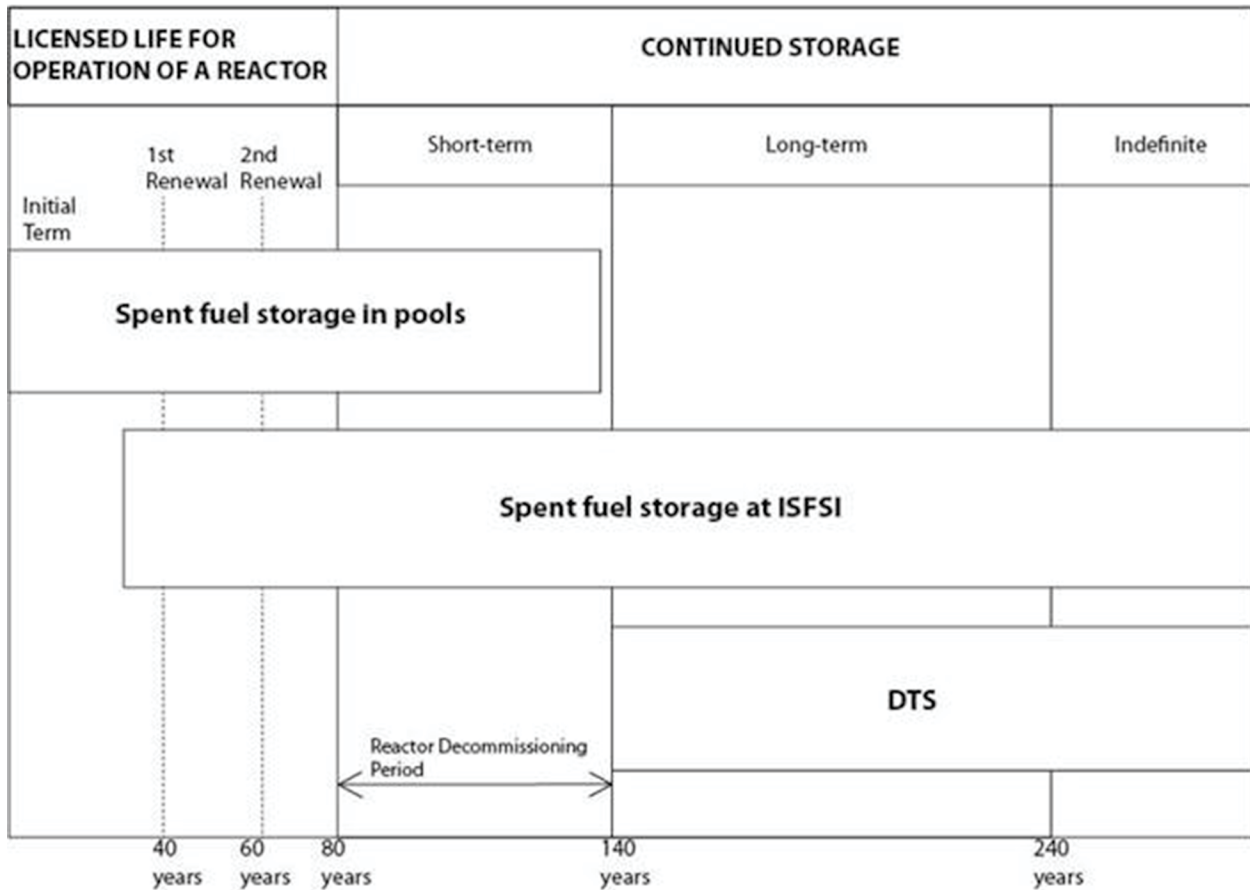

Figure 2-4. Continued Storage Timeline

2.2.1.1 Decommissioning Activities during Short-Term Storage

A number of activities occur after a reactor licensee declares permanent cessation of operations. These activities are divided into three phases: (1) initial activities; (2) major decommissioning and storage activities; and (3) license-termination activities. The initial activities include the licensee's certification to the NRC within 30 days of the decision or requirement to permanently cease operations. This is followed by certification of permanent fuel removal from the reactor. Within 2 years of permanent shutdown, the licensee is required to submit to the NRC a post-shutdown decommissioning activities report that includes a description of planned decommissioning activities along with a schedule, an estimate of expected costs, and a discussion that provides the reasons for concluding that previously issued environmental impact statements bound the site-specific decommissioning activities (NRC 2013c).

Generic Facility Descriptions and Activities

Licensees may choose from three decommissioning options: DECON, SAFSTOR, and ENTOMB:

DECON: The equipment, structures, and portions of the facility and site that contain radioactive contaminants are removed or decontaminated to a level that permits termination of the license shortly after cessation of operations.

SAFSTOR: The facility is placed in a safe, stable condition and maintained in that state until it is subsequently decontaminated and dismantled to levels that permit license termination. During SAFSTOR, a facility is left intact, but the fuel is removed from the reactor vessel and radioactive liquids are drained from systems and components and then processed. Radioactive decay occurs during the SAFSTOR period, which reduces the levels of radioactivity in and on the material and, potentially, the quantity of material that must be disposed of during decontamination and dismantlement.

ENTOMB: ENTOMB involves encasing radioactive structures, systems, and components within a structurally long-lived substance, such as concrete. The entombed structure is appropriately maintained, and continued surveillance is carried out until the radioactivity decays to a level that permits termination of the license¹⁰ (NRC 2013c). The NRC has previously considered a range of likely ENTOMB scenarios. For all scenarios considered, spent fuel was removed from the spent fuel pool prior to entombment (NRC 2002a). While the nuclear power industry has expressed interest in maintaining the option for ENTOMB, no licensees have committed to using it (NRC 2002c).

The choice of decommissioning option is left to the licensee, but decommissioning must conform to the NRC's regulations. This choice is communicated to the NRC and the public in the post-shutdown decommissioning activities report. In addition, the licensee may choose to combine the DECON and SAFSTOR options. For example, after power operations cease at a facility, a licensee could use a short storage period for planning purposes, followed by removal of large components (such as the steam generators, pressurizer, and reactor vessel internals), place the facility in storage for 30 years, and eventually finish the decontamination and dismantlement process (NRC 2013c).

If a licensee needs to change the decommissioning schedules or activities identified in the post-shutdown decommissioning activity report, or if the decommissioning costs increase significantly, 10 CFR 50.82(a)(7) and 52.110(g) require the licensee to notify the NRC in writing

¹⁰ Because most power reactors will have radionuclides in concentrations exceeding the limits for unrestricted use even after 100 years, this option will generally not be feasible (NRC 2013c).

and send a copy to the affected States. The NRC uses the post-shutdown decommissioning activity report and any written notification of changes to manage decommissioning oversight activities.

Decommissioning will be completed within 60 years of permanent cessation of operations in accordance with the license-termination requirements for power reactors in 10 CFR 50.82(a)(3) and 52.110(c). Completion of decommissioning beyond 60 years will be approved by the Commission only when necessary to protect public health and safety. Factors that will be considered by the Commission include unavailability of waste disposal capacity and other site-specific factors, including the presence of other nuclear facilities at the site. Given this regulatory framework, it may be reasonably assumed that each nuclear power plant, including its onsite spent fuel pool, will be decommissioned within 60 years of permanent cessation of operations.

Licensees may begin major decommissioning activities 90 days after the NRC has received the post-shutdown decommissioning activities report. The term “major decommissioning activity” is defined in 10 CFR 50.2 and means, for a nuclear power reactor facility, any activity that results in permanent removal of major radioactive components, permanently modifies the structure of the containment, or results in dismantling components for shipment containing greater-than-class-C low-level waste as defined in 10 CFR 61.55. Finally, once decommissioning is completed, and any spent fuel stored by the licensee is removed from the site, a licensee may apply to the NRC to terminate its Part 50 or Part 52 license.¹¹ A licensee is required by 10 CFR 50.82(a)(9) or 52.110(i)(1) to submit to the NRC a license-termination plan as a supplement to its final safety analysis report at least 2 years prior to the expected termination of the license as scheduled in the post-shutdown decommissioning activities report.

Decommissioning activities are not a part of continued storage. Therefore, decommissioning costs are not included in this GEIS.

2.2.1.2 Activities in Spent Fuel Pools

Spent fuel pools are cooled by continuously circulating water that cools the spent fuel assemblies and provides shielding from radiation. During the short-term storage timeframe, the pools will be used to store fuel until a licensee decides to remove the spent fuel as part of implementing the selected decommissioning option. Beyond the short-term storage timeframe, the NRC assumes that all of the spent fuel has been transferred to a dry cask storage system in an at-reactor or away-from-reactor ISFSI, which is consistent with current practice.

¹¹ A licensee may terminate its Part 50 or Part 52 license earlier if the remaining spent fuel is stored under a specific license issued under 10 CFR Part 72.

Generic Facility Descriptions and Activities

Operation and maintenance of spent fuel pools as well as the handling and transfer of spent fuel from spent fuel pools to ISFSIs are continued storage activities for the short-term timeframe. The U.S. Government Accountability Office (GAO) estimated the annual costs for operating and maintaining a spent fuel pool at a decommissioning reactor site (GAO 2012). Based on GAO's 2012 estimates, the NRC estimates that costs range from \$8.2M to \$13.4M per year. For loading the fuel from the pools into dry cask storage, EPRI estimated costs for the initial cask procurement and loading (EPRI 2012). Based on EPRI's estimates, the NRC estimates costs to be \$1.34M per cask. Based on the estimate of \$1.34M per dry cask, the costs for transferring all of the spent fuel from the pool to dry cask for a 1,600 MTU facility (assuming 160 dry casks) would be \$214M. This cost estimate is conservative because some of the spent fuel may have been moved into dry casks before the end of the licensed life for operation of a reactor; therefore, those costs would not be incurred during continued storage.

During the short-term storage timeframe, spent fuel in the pool continues to generate decay heat from radioactive decay. The rate at which the decay heat is generated decreases the longer the reactor has been shut down. Storing the spent fuel in a pool of water provides a heat sink adequate for the removal of heat from the irradiated fuel. In addition, the fuel is located under water so that the radiation emanating from the fuel is shielded by the water, thus significantly limiting worker exposure to radiation. After the spent fuel has cooled adequately, it can be removed from the pool and stored in an ISFSI in air-cooled dry casks. At the earliest, such as for low-burnup spent fuel, transfer of spent fuel to an ISFSI occurs after the fuel has cooled for 5 years (NRC 2002a). Minimum cooling times for high-burnup fuel vary with burnup and initial uranium enrichment for different dry cask storage systems, ranging from 5 years to greater than 20 years.

Spent fuel pools are cooled by spent fuel pool cooling systems, which typically consist of pumps to circulate cooling water through the system, a purification system of filters and a demineralizer, and a heat exchanger (which transfers the heat from the spent fuel pool cooling system to the service-water system or its equivalent). The operation of the purification system generates some liquid low-level radioactive waste and some solid low-level radioactive waste in the form of demineralizer resins. During decommissioning, some licensees opt to modify the existing spent fuel pool support systems by installing self-contained spent fuel pool cooling and cleanup systems and monitoring, controls and electrical power. These modifications effectively isolate the spent fuel pool from the remainder of plant structures, systems, and components, thereby creating a "spent fuel pool island." This approach allows decommissioning to begin on the remainder of the plant while the spent fuel is safely stored (EPRI 2005). As described in Chapter 4 of this GEIS, the operation of a new self-contained system would be bounded by the impacts of operating the existing cooling system, which are also described in Chapter 4. The environmental impacts of constructing a new spent fuel pool cooling system, which facilitates decommissioning activities, are addressed in Chapter 6 of this GEIS.

For plants that enter SAFSTOR, the spent fuel pool will continue to be subject to preventative and corrective maintenance, including maintenance of the structure, its security systems, radiation protection and environmental monitoring programs, and processing of radioactive waste that may be generated.

For purposes of analysis in this GEIS, the NRC assumes timely decommissioning of the reactor in accordance with requirements in 10 CFR 50.82 or 52.110(c). As a result, all spent fuel in storage in the spent fuel pool is assumed to be transported to a repository, if it is available, or to either an at-reactor or away-from-reactor ISFSI within 60 years beyond the licensed life for operation of the reactor.

2.2.1.3 Activities at At-Reactor ISFSIs

Operation and maintenance activities at an at-reactor ISFSI are focused on inspections, monitoring, and training. The staff that must be trained for ISFSI operations include staff for operations, maintenance, health physics, and security. A licensee will also maintain an emergency response plan for ISFSI-related events.

At-reactor ISFSI operation and maintenance are continued storage activities in the short-term, long-term, and indefinite timeframes. EPRI developed estimates for routine annual operation and maintenance costs for an at-reactor ISFSI (EPRI 2012). Based on EPRI's estimates, the NRC estimates annual costs of \$6.4M. Construction of an at-reactor ISFSI is not a continued storage activity in the short-term timeframe.

In accordance with 10 CFR 72.42 for specifically licensed ISFSIs, the initial license term for an ISFSI must not exceed 40 years and licenses may be renewed upon NRC approval for a period not to exceed 40 years. In accordance with 10 CFR 72.212, a general license for spent fuel storage in a cask fabricated under a Certificate of Compliance commences on the date that the cask is first used by a general licensee and continues through any renewals of the Certificate of Compliance, unless otherwise specified in the Certificate of Compliance, and terminates when the Certificate of Compliance for the cask expires. Renewal applications for specifically licensed ISFSIs and spent fuel storage cask designs approved for use under the general license must include, among other things: (1) time-limited aging analyses that demonstrate structures, systems, and components important to safety will continue to perform their intended safety function for the requested period of extended operation and (2) a description of the aging management program for management of issues associated with aging that could adversely affect structures, systems, and components important to safety. The NRC reviews renewal applications using its *Standard Review Plan for Renewal of Spent Fuel Dry Cask Storage System Licenses and Certificates of Compliance* (NRC 2011b).

The kinds of aging effects managed under an aging management program include, but are not limited to concrete cracking and spalling; cask and canister confinement boundary material

Generic Facility Descriptions and Activities

degradation; and reduction in heat transfer (e.g., by blocked air duct screens). The application of aging management programs may include structure monitoring; monitoring of protective coating on carbon steel structures; ventilation surveillance; welded canister seal and leakage monitoring programs; and bolted canister seal and leakage monitoring programs (DOE 2012).

2.2.1.4 Activities at Away-from-Reactor ISFSIs

In assessing environmental impacts from construction and operation at an away-from-reactor ISFSI, the NRC has drawn from the PFS facility environmental impact statement prepared by the NRC (NRC 2001). The proposed PFS facility was designed to store up to 40,000 MTU and was licensed to operate for 20 years. The NRC now allows an initial license term of 40 years with 40-year renewal terms. While this GEIS uses the general attributes of such a facility to assess likely impacts for purposes of this analysis, it should be recognized that the environmental impacts of constructing and operating an away-from-reactor ISFSI would be evaluated in more detail in an environmental review associated with a site-specific license application.

Based on the construction plans for the proposed PFS facility, construction of the away-from-reactor ISFSI would include construction of major buildings (e.g., administrative, security, and maintenance) including a canister transfer building and installation of concrete storage pads, batch plant, access and heavy haul roads, parking areas, and potentially new rail lines. A peak workforce of approximately 250 workers would be expected (NRC 2001). Groundwater wells could be installed for potable water use or aboveground storage tanks could be erected for potable water and water for fires and the concrete plant.

Should storage at an away-from-reactor ISFSI continue for a long enough time for bare fuel handling to be required for inspection or maintenance, then a DTS could be constructed at the facility.

Operation of the away-from-reactor ISFSI would include receiving, transferring, storing, and repackaging of spent fuel. If a repository becomes available, operations could include transferring spent fuel canisters to shipping casks and transporting them to the repository.

Approximately 100 to 200 loaded shipping casks would be received at the postulated facility each year (NRC 2001). The shipping casks would be brought into the canister transfer building where the spent fuel would be transferred from the shipping cask to a storage cask. The storage casks would then be placed on the concrete storage pads.

Away-from-reactor ISFSI construction, operation, and maintenance are continued storage activities in the short-term, long-term, and indefinite timeframes. Section 2.1.3 discusses away-from-reactor ISFSI construction costs. The initial away-from-reactor ISFSI constructed during the short-term timeframe includes transportation capital costs and is estimated to be \$680M

(see Section 2.1.3). EPRI estimated the total annual routine costs for operation and maintenance during “caretaker” periods (i.e., when loading and unloading is not occurring) (EPRI 2009). This estimate included administrative costs, labor costs, and other operating costs (excluding railroad freight fees and State inspection fees). Based on EPRI’s estimates, the NRC estimates annual costs for “caretaker” periods of \$11.6M.

Continued storage costs will include transportation activities to move spent fuel to an away-from-reactor ISFSI. These transportation costs include initial costs for cask procurement and loading, additional labor costs associated with loading and unloading transportation casks (i.e., labor cost beyond the annual routine caretaker costs), and shipping costs (i.e., railroad freight fees). As described in Section 2.1.3, transportation casks and other transportation equipment capital costs are accounted for in the storage facility construction cost. The costs for initial cask procurement and loading are assumed to be the same as the costs for the at-reactor facility, which are estimated to be \$1.34M (see Section 2.2.1.2). EPRI also estimated annual transportation of 200 casks (i.e., 2,000 MTU of spent fuel) to an away-from-reactor ISFSI (EPRI 2009). Based on EPRI’s estimates, the NRC estimates additional annual labor costs of \$5.3M for loading and unloading the transportation casks and \$41.5M in railroad fees and State inspection fees.

To completely fill a 40,000 MTU (assuming 4,000 casks) capacity away-from-reactor facility costs \$5,350,000,000 (\$5.35B) for initial cask procurement and loading, \$106M for the additional labor associated with loading and unloading transportation casks, and \$830M for transportation fees. The total cost for initially constructing and filling a 40,000 MTU capacity away-from-reactor ISFSI is \$6.97B.

2.2.2 Long-Term Storage Activities

As described below, the new activities associated with long-term storage include continued facility maintenance, construction, and operation of a DTS, and storage facility replacement. The maintenance activities during the long-term storage activities are the same as for the short-term, including any additional monitoring and inspections that may arise as part of implementation of ongoing aging management programs. The annual costs for routine ISFSI operation and maintenance described in Section 2.2.1.3 in the short-term timeframe would continue throughout the long-term timeframe.

2.2.2.1 Construction and Operation of a DTS

As described in Section 2.1.4, the NRC assumes a DTS, or its equivalent, would be used to transfer fuel as needed for inspection or repackaging. For the purposes of this GEIS, the NRC assumes the reference DTS would be constructed, operated, and replaced once during the long-term storage timeframe, and every 100 years thereafter. The reference DTS would occupy about 0.04 ha (0.1 ac) and would have a total restricted access area of 0.7 ha (2 ac). The NRC

Generic Facility Descriptions and Activities

assumes that construction of a reference DTS would take 1 to 2 years. Section 2.1.4 discusses construction costs for a DTS. Operation costs for the DTS, described in Section 2.2.2.2, are associated with the labor to transfer spent fuel from old casks to new casks.

DOE has described the operation of a reference DTS in the *Dry Transfer System Topical Safety Analysis Report* (DOE 1996). A summary is provided here to illustrate the process of spent fuel repackaging.

The reference DTS includes three major areas:

- preparation area,
- lower access area, and
- transfer confinement area.

As shown in Figure 2-3, receiving casks and source casks enter the preparation area and exit the DTS on rail-mounted trolleys. To begin spent fuel transfer operations, a receiving cask (i.e., the cask into which fuel will be transferred) is transported to the DTS. The receiving cask is positioned and loaded on a receiving cask transfer trolley at the DTS and rolled into the preparation area. Next, the receiving cask lid and outer and inner canister lids are removed. Finally, the receiving cask is moved into the lower access area and mated to the transfer confinement area.

A source cask (i.e., the cask from which fuel will be transferred) follows a similar path as the receiving cask into the lower access area and is mated to the transfer confinement area. No personnel are present in the lower access area for the transfer operations; all transfer operations are controlled remotely. The lids on both the receiving cask and source cask are removed to prepare for spent fuel transfer. The fuel-assembly-handling subsystem in the transfer confinement area is used to grab and lift a spent fuel assembly from the source cask. The spent fuel assembly is lifted inside a transfer tube and then moved over an empty position in the receiving cask. The spent fuel assembly is lowered into the receiving cask and detached from the lifting device. When spent fuel transfers are complete, both casks are closed, detached from the transfer confinement area, and ultimately removed from the lower access area back to the preparation area.

Maintenance and monitoring activities at the DTS would include routine inspections and testing of the spent fuel and cask transfer and handling equipment (e.g., lift platforms and associated mechanical equipment) and process and effluent radiation monitoring.

Damaged Fuel

As stated in Section 2.1.4, one reason DTSs may be needed in the future is to reduce risks associated with unplanned events (e.g., the need to repackage spent fuel that becomes

damaged or that becomes susceptible to damage while in dry cask storage). The NRC defines damaged spent fuel as any fuel rod or fuel assembly that can no longer fulfill its fuel-specific or system-related functions (NRC 2007). These functions include criticality safety, radiation shielding, confinement, and retrievability of the fuel. Appendix B of this GEIS describes spent fuel degradation mechanisms that could occur during continued storage. These include a mechanism (i.e., hydride reorientation) in which high-burnup spent fuel cladding can become less ductile (more brittle) over time as cladding temperatures decrease. Taking actions (e.g., repackaging or providing supplemental structural support) can reduce risks posed by damaged fuel by maintaining fuel-specific or system-related safety functions.

The Transnuclear-EPRI DTS described by DOE in its topical safety analysis report (DOE 1996) and summarized in Section 2.1.4 of this GEIS does not have the capability to handle damaged spent fuel, which the DOE defined as spent fuel that is not dimensionally or structurally sound and spent fuel that cannot be handled by normal means. However, as a result of its experience with damaged spent fuel, described in more detail in the following paragraphs, the nuclear power industry has developed specialized tools that could be deployed if damaged spent fuel needs to be retrieved from a dry cask storage system. Therefore, NRC considers it reasonable to assume that a DTS similar to the Transnuclear-EPRI DTS could be designed, constructed, and equipped to handle damaged fuel.

International experience provides a broad understanding of the technical feasibility of various methods for handling damaged fuel. An International Atomic Energy Agency (IAEA 2009) technical report documented the types of methods that have been used separately or in combination to handle damaged spent fuel under a variety of circumstances while maintaining specific safety functions. The methods include removing rods, canning, replacing or repairing damaged structural components, and providing supplemental structural support. When a single rod in a fuel assembly is damaged, the damaged rod can be removed to restore the integrity of the fuel assembly, but that process leaves a gap in the fuel assembly. Rod replacement involves replacing the damaged rod with a steel rod to maintain the structural integrity of the assembly to facilitate transfer. Structural repair or replacement involves repairing or replacing damaged components in the assembly (e.g., grid spacers, vanes, and tie plates) to restore stability of the assembly. Supplemental structural support involves adding mechanical strengthening to the assembly to address loss of capabilities from a damaged part.

The NRC requires that spent fuel classified as damaged for storage be protected during storage (e.g., placed in a can designed for damaged fuel, referred to as a damaged fuel can or damaged fuel container (NRC 2007)).¹² A damaged fuel can is designed to ensure that the fuel-specific or system-related functions continue to be met. When a spent fuel assembly is placed

¹² An acceptable alternative approved by the NRC is to confine damaged spent fuel using top and bottom “end caps” in dry cask storage system basket cells (Transnuclear, Inc. 2011).

in a damaged fuel can, one or more of the necessary safety functions, depending on the type of can, are performed by the can instead of the spent fuel assembly (IAEA 2009). A damaged fuel can will confine fuel particles, debris, and the damaged spent fuel to a known volume in a cask; ensure compliance with criticality safety, shielding, thermal, and structural requirements; and permit normal handling and retrieval of spent fuel from a cask. An additional example of a method approved by the NRC for providing supplemental structural support to damaged fuel involves using instrument tube tie rods to reinforce PWR spent fuel assembly top nozzles that have suffered inter-granular stress corrosion cracking (74 FR 26285).

In current dry cask storage system designs, damaged fuel cans are placed in a limited number of positions inside the canister or cask (Transnuclear, Inc. 2011). Because a damaged fuel can performs the safety functions of undamaged fuel components (i.e., criticality safety, shielding, confinement, retrievability, etc.), the presence of damaged fuel cans in dry cask storage systems would not cause environmental impacts during continued storage different from casks containing undamaged spent fuel. For this reason, this GEIS does not further consider generic environmental impacts associated with use of damaged fuel cans or their alternatives.

2.2.2.2 Replacement of Storage and Handling Facilities

For purposes of analysis in this GEIS, the NRC assumes that storage facilities will require complete replacement over the long-term storage timeframe (100 years). Replacement activities are assumed to occur as needed throughout the long-term storage timeframe, but not all at once over a relatively short interval (e.g., 2 years). Replacement activities include the following:

- construction of new ISFSI pads near the initial pads,
- construction of replacement storage casks or HSMs,
- movement of canisters in good condition to new casks or HSMs,
- use of the initial and replacement DTS to transfer fuel to new canisters and casks, as necessary, and
- replacement of the DTS.

Continued storage activities include replacing the storage facility (for either an at-reactor or an away-from reactor ISFSI), the DTS, and the spent fuel canisters and casks. Replacing the ISFSI and DTS requires dismantling the existing facilities and constructing new ones. The costs for dismantling the existing ISFSIs are based on decommissioning activities. Using decommissioning costs conservatively bounds the dismantling costs because there would be fewer activities associated with dismantling than for decommissioning as the site is not being released for other uses. Dismantling costs for at-reactor ISFSIs are based on licensee

information (Nuclear Management Company, LLC 2005) and dismantling costs for away-from-reactor ISFSIs are based on EPRI information (EPRI 2009).

The NRC estimates costs for dismantling the existing facility at \$7.6M for an at-reactor ISFSI and \$248M for an away-from-reactor ISFSI. The cost for dismantling the DTS is the same for both the at-reactor and away-from-reactor facilities. Although the decommissioning cost for a DTS is not known, the decommissioning cost of an away-from reactor ISFSI is about 40 percent of the initial construction costs (see Section 2.1.3). Applying this same 40 percent difference between the DTS construction and demolition costs results in an estimated DTS dismantling cost of \$3.43M. Construction of a replacement at-reactor facility costs \$107M (see Section 2.1.2.2) and construction of a replacement away-from-reactor facility costs \$215M (see Section 2.1.3). Construction of a replacement DTS costs \$8.58M (see Section 2.1.4). Using the costs for initial construction as estimates for constructing replacement facilities can be considered conservative because start-up costs (e.g., design, engineering, and licensing cost) may be lower for subsequent construction at the same location.

Replacing a cask requires procurement of a new cask and the labor to unload the fuel from the old cask and then load the fuel into the new cask. EPRI estimated costs for cask procurement and loading (EPRI 2012). Based on EPRI's estimates, the NRC estimates that replacing a single cask costs \$1.66M, which includes procuring a new cask at \$1.02M, unloading fuel from the old cask at \$321,000, and subsequent loading of spent fuel into the new cask at \$321,000. The initial transfer of spent fuel into a dry cask costs \$1.34M per cask (see Section 2.2.1.2) because the unloading of spent fuel from the old cask is not required. The labor costs for replacing a single cask can be considered conservative because the unloading of the old cask and loading of the new cask occur essentially as one operation. Replacing all 160 casks for a 1,600 MTU at-reactor ISFSI (assuming 10 MTU per cask) can then be estimated to cost \$265M, and replacing all 4,000 casks for a 40,000 MTU away-from-reactor ISFSI (assuming 10 MTU per cask) costs \$6.64B. The total cost for complete replacement of an at-reactor storage facility (i.e., dismantling the old ISFSI and DTS, building a new ISFSI and DTS, procuring new casks, and transferring the spent fuel from the old facilities to the new facilities) is about \$392M. The total cost for complete replacement of an away-from-reactor facility is about \$7.11B.

2.2.3 Indefinite Storage Activities

Should a repository not become available within the long-term storage timeframe, then activities described for the long-term storage timeframe in Section 2.2.2 are assumed to continue indefinitely. For purposes of analysis in this GEIS, the NRC assumes that storage facilities (i.e., an ISFSI and its associated DTS) would be replaced once every 100 years. The costs for replacement of storage and handling facilities discussed in Section 2.2.2.2 would therefore be realized every 100 years as well. The annual costs for routine ISFSI operation and maintenance described in Section 2.2.1.3 for the short-term timeframe would continue.

2.3 References

10 CFR Part 20. *Code of Federal Regulations*, Title 10, *Energy*, Part 20, “Standards for Protection against Radiation.” Washington, D.C.

10 CFR Part 50. *Code of Federal Regulations*, Title 10, *Energy*, Part 50, “Domestic Licensing of Production and Utilization Facilities.” Washington, D.C.

10 CFR Part 52. *Code of Federal Regulations*, Title 10, *Energy*, Part 52, “Licenses, Certifications, and Approvals for Nuclear Power Plants.” Washington, D.C.

10 CFR Part 61. *Code of Federal Regulations*, Title 10, *Energy*, Part 61, “Licensing Requirements for Land Disposal of Radioactive Waste.” Washington, D.C.

10 CFR Part 71. *Code of Federal Regulations*, Title 10, *Energy*, Part 71, “Packaging and Transportation of Radioactive Material.” Washington, D.C.

10 CFR Part 72. *Code of Federal Regulations*, Title 10, *Energy*, Part 72, “Licensing Requirements for the Independent Storage of Spent Nuclear Fuel, High-Level Radioactive Waste, and Reactor-Related Greater than Class C Waste.” Washington, D.C.

74 FR 13926. March 27, 2009. “Power Reactor Security Requirements.” *Federal Register*, U.S. Nuclear Regulatory Commission, Washington, D.C.

74 FR 26285. June 2, 2009. “List of Approved Spent Fuel Storage Casks: HI-STORM 100 Revision 6.” *Federal Register*, U.S. Nuclear Regulatory Commission, Washington D.C.

76 FR 30399. May 25, 2011. “Duke Energy Carolinas, LLC, Oconee Nuclear Station, Units 1, 2, and 3, Notice of Consideration of Issuance of Amendment to Facility Operating License, Proposed No Significant Hazards Consideration Determination, and Opportunity for a Hearing and Order Imposing Procedures for Document Access to Sensitive Unclassified Non-Safeguards Information.” *Federal Register*, U.S. Nuclear Regulatory Commission, Washington, D.C.

77 FR 16175. March 20, 2012. “Station Blackout.” *Federal Register*, U.S. Nuclear Regulatory Commission, Washington D.C.

78 FR 21275. April 10, 2013. “Station Blackout Mitigation Strategies.” *Federal Register*, U.S. Nuclear Regulatory Commission, Washington D.C.

ANSI/ANS (American National Standards Institute/American Nuclear Society). 1992. *Design Criteria for an Independent Spent Fuel Storage Installation (Dry Storage Type)*.

ANSI/ANS 57.9–1992, La Grange Park, Illinois. Available at http://www.techstreet.com/cgi-bin/detail?doc_no=ans%7C57_9_1992_r2000;product_id=21087.

BLS (U.S. Bureau of Labor Statistics). 2014a. *CPI Inflation Calculator*. Washington, D.C. Available at http://www.bls.gov/data/inflation_calculator.htm.

BLS (U.S. Bureau of Labor Statistics). 2014b. *CPI Detailed Report— Data for March 2014*. Washington, D.C. Available at <http://www.bls.gov/cpi/cpid1403.pdf>.

BRC (Blue Ribbon Commission on America's Nuclear Future). 2012. *Report to the Secretary of Energy*. Washington, D.C. Accession No. ML120970375.

Carlsen, B.W. and M.B. Raap. 2012. *Dry Transfer Systems for Used Nuclear Fuel*. INL/EXT–12–26218, Idaho National Laboratory, Idaho Falls, Idaho. Available at <http://www.inl.gov/technicalpublications/Documents/5516346.pdf>.

Copinger, D.A., C.B. Oland, and D.J. Naus. 2012. *Summary of Aging Effects and Their Management in Reactor Spent Fuel Pools, Refueling Cavities, Tori, and Safety-Related Concrete Structures*. NUREG/CR–7111, Oak Ridge National Laboratory, Oak Ridge, Tennessee. Accession No. ML12047A184.

CRS (Congressional Research Service). 2012. *U.S. Spent Nuclear Fuel Storage*. Washington, D.C. Accession No. ML14142A043.

DOE (U.S. Department of Energy). 1996. *Dry Transfer System Topical Safety Analysis Report*. Volume I, Washington, D.C. Accession No. ML060730035.

DOE (U.S. Department of Energy). 2012. *Managing Aging Effects on Dry Cask Storage Systems for Extended Long-Term Storage and Transportation of Used Fuel*. FCRD–USED–2012–000119, ANL–12/29, Washington, D.C. Available at <http://www.ipd.anl.gov/anlpubs/2012/07/73873.pdf>.

DOE (U.S. Department of Energy). 2013. *Strategy for the Management and Disposal of Used Nuclear Fuel and High-Level Radioactive Waste*. Washington, D.C. Accession No. ML13011A138.

EIA (Energy Information Administration). 1994. *Spent Nuclear Fuel Discharges from U.S. Reactors 1992*. SR/CNEAF/94–01, Washington, D.C. Available at <http://www.ntis.gov/search/product.aspx?ABBR=DE94011195>.

Entergy (Entergy Nuclear Operations, Inc.). 2013. *Notification of Permanent Cessation of Power Operations*. White Plains, New York. Accession No. ML13273A204.

Generic Facility Descriptions and Activities

EPRI (Electric Power Research Institute). 1988. *An Assessment of Boraflex Performance in Spent-Nuclear-Fuel Storage Racks*. NP-6159, Palo Alto, California. Accession No. ML003736666.

EPRI (Electric Power Research Institute). 1995. *Dry Transfer System for Spent Fuel: Project Report: A System Designed to Achieve Dry Transfer of Bare Spent Fuel between Two Casks*. Report No. 1018722, Palo Alto, California.

EPRI (Electric Power Research Institute). 2005. *Maine Yankee Decommissioning—Experience Report: Detailed Experiences 1997–2004*. Technical Report No. 1011734, Palo Alto, California. Accession No. ML12338A389.

EPRI (Electric Power Research Institute). 2009. *Cost Estimate for an Away-From-Reactor Generic Interim Storage Facility (GISF) for Spent Nuclear Fuel*. Report No. 1018722, Palo Alto, California. Available at <http://cybercemetery.unt.edu/archive/brc/20120621082619/http://brc.gov/sites/default/files/documents/1018722.pdf>.

EPRI (Electric Power Research Institute). 2012. *Impacts Associated With Transfer of Spent Nuclear Fuel from Spent Fuel Storage Pools to Dry Storage After Five Years of Cooling, Revision 1*. TR-1025206, Palo Alto, California. Available at <http://www.epri.com/abstracts/Pages/ProductAbstract.aspx?ProductId=00000000001021049>.

GAO. (U.S. Governmental Accountability Office). 2012. *Spent Nuclear Fuel: Accumulating Quantities at Commercial Reactors Present Storage and Other Challenges*. GAO-12-797, Washington, D.C. Available at <http://www.gao.gov/assets/600/593745.pdf>.

Hanson, B., H. Alsaed, C. Stockman, D. Enos, R. Meyer, and K. Sorenson. 2012. *Gap Analysis to Support Extended Storage of Used Nuclear Fuel Rev. 0*. U.S. Department of Energy Report No. FCRD-USED-2011-000136 Rev. 0, Richland, Washington. Available at <http://energy.gov/sites/prod/files/Gap%20Analysis%20Rev%200%20Final.pdf>.

Holtec (Holtec International). 2000. *Final Safety Analysis Report for the Holtec International Storage and Transfer Operation Reinforced Module Cask System (HI-STORM 100 Cask System)*. Revision 0. Marlton, New Jersey. Accession No. ML072420254.

IAEA (International Atomic Energy Agency). 2009. *Management of Damaged Spent Nuclear Fuel*. IAEA Nuclear Energy Series No. NF-T-3.6, Vienna, Austria. Available at http://www-pub.iaea.org/MTCD/publications/PDF/Pub1395_web.pdf.

Nuclear Management Company, LLC. 2005. *Irradiated Fuel Management Plan*. November 30. Two Rivers, Wisconsin. Accession No. ML053360051.

NRC (U.S. Nuclear Regulatory Commission). 2000. Letter from E. W. Brach to L. Steward dated November 13, 2000, regarding “Issuance of Assessment Report for the Dry Transfer System.” Washington, D.C. Accession Nos. ML003769027 (letter) and ML003769386.

NRC (U.S. Nuclear Regulatory Commission). 2001. *Final Environmental Impact Statement for the Construction and Operation of an Independent Spent Fuel Storage Installation on the Reservation of the Skull Valley Band of Goshute Indians and Related Transportation Facility in Tooele County, Utah*. NUREG–1714, Volume 1, Washington, D.C. Accession No. ML020150170.

NRC (U.S. Nuclear Regulatory Commission). 2002a. *Final Generic Environmental Impact Statement on Decommissioning of Nuclear Facilities Supplement 1 Regarding the Decommissioning of Nuclear Power Reactors*. NUREG–0586, Volumes 1 and 2, Washington, D.C. Accession Nos. ML023470327 and ML023500228.

NRC (U.S. Nuclear Regulatory Commission). 2002b. “In the Matter of General Electric Company—Morris Operation: Order Modifying License (Effective Immediately).” Washington, D.C. Accession No. ML021080507.

NRC (U.S. Nuclear Regulatory Commission). 2002c. *Status of the Entombment Option for Power Reactors*. SECY-02-0191, Washington, D.C. Accession No. ML022630660.

NRC (U.S. Nuclear Regulatory Commission). 2004a. *General Electric Company Morris Operation Technical Specifications for Safety*. License SNM–2500, Morris, Illinois. Accession No. ML043630567.

NRC (U.S. Nuclear Regulatory Commission). 2004b. *Environmental Impact Statement for the Proposed Idaho Spent Fuel Facility at the Idaho National Engineering and Environmental Laboratory in Butte County, Idaho*. NUREG–1773, Washington, D.C. Accession No. ML040490135.

NRC (U.S. Nuclear Regulatory Commission). 2007. *Division of Spent Fuel Storage and Transportation Interim Staff Guidance - 1, Revision 2, Classifying the Condition of Spent Nuclear Fuel for Interim Storage and Transportation Based on Function*. SFST-ISG-2, Revision 2, Washington, D.C. Accession No. ML071420268.

NRC (U.S. Nuclear Regulatory Commission). 2011a. *Recommendations for Enhancing Reactor Safety in the 21st Century: The Near-Term Task Force Review of Insights from the Fukushima Dai-ichi Accident*. SECY–11–0093, Washington, D.C. Accession No. ML111861807.

Generic Facility Descriptions and Activities

NRC (U.S. Nuclear Regulatory Commission). 2011b. *Standard Review Plan for Renewal of Spent Fuel Dry Cask Storage System Licenses and Certificates of Compliance*. NUREG–1927, Washington, D.C. Accession No. ML111020115.

NRC (U.S. Nuclear Regulatory Commission). 2012. *Report to Congress: Advanced Reactor Licensing*. Washington, D.C. Accession No. ML12153A014.

NRC (U.S. Nuclear Regulatory Commission). 2013a. *Generic Environmental Impact Statement for License Renewal of Nuclear Plants*. NUREG–1437, Revision 1, Washington, D.C. Accession No. ML13107A023.

NRC (U.S. Nuclear Regulatory Commission). 2013b. *2013–2014 Information Digest*. NUREG–1350, Volume 25, Washington, D.C. Accession No. ML13241A207.

NRC (U.S. Nuclear Regulatory Commission). 2013c. *Decommissioning of Nuclear Power Reactors*. Regulatory Guide 1.184, Revision 1, Washington, D.C. Accession No. ML13144A840.

NRC (U.S. Nuclear Regulatory Commission). 2014. *U.S. Independent Spent Fuel Storage Installations*. Washington, D.C. Accession No. ML14162A091.

PFS (Private Fuel Storage LLC). 2012. Letter from R. Palmberg to NRC, dated December 20, 2012, regarding “Termination of NRC License No. SNM–2513 for Private Fuel Storage LLC.” La Crosse, Wisconsin. Accession No. ML12356A063.

S. Cohen & Associates, Inc. 1998. *Effectiveness of Fuel Rod Cladding as an Engineered Barrier in the Yucca Mountain Repository*. McLean, VA. Accession No. ML033500112.

Sailor, V.L., K.R. Perkins, J.R. Weeks, and H.R. Connell. 1987. *Severe Accidents in Spent Fuel Pools in Support of Generic Safety Issue 82*. NUREG/CR–4982, Brookhaven National Laboratory, Upton, New York. Available at <http://www.osti.gov/bridge/servlets/purl/6135335-5voofL/6135335.pdf>.

Transnuclear, Inc. 2011. *NUHOMS® 37PTH Dry Shielded Canister*. ANP:U-291-V2-11-ENG, Columbia, Maryland. Available at http://us.areva.com/home/liblocal/docs/Solutions/literature/ANP_U_291_V2_11_ENG_NUHOMS_37PTH.pdf.

UxC (Ux Consulting). 2013. “Over 1700 Dry Storage Systems Deployed in the US.” *StoreFUEL* 14(173):14–173, Roswell, Georgia.

3.0 Affected Environment

For purposes of the evaluation in this *Generic Environmental Impact Statement for Continued Storage of Spent Nuclear Fuel* (GEIS), the *affected environment* is the environment that exists at and around the facilities that store spent nuclear fuel (spent fuel) after the end of a reactor's licensed life for operation. Spent fuel is stored in at-reactor spent fuel pools and independent spent fuel storage installations (ISFSIs). Where appropriate, this chapter will discuss the environmental impacts during reactor operations to establish the baseline affected environment at the beginning of continued storage.

The affected environment and potential impacts of continued storage at an away-from-reactor ISFSI are discussed in Chapter 5 and are not addressed further in this chapter. Because conditions at at-reactor ISFSIs are at least partially the result of past construction and operations at power plants, the impacts of these past and ongoing operations and how they have shaped the environment help to establish the baseline affected environment. A comprehensive description of the affected environment during operations is provided in the *Generic Environmental Impact Statement for License Renewal of Nuclear Plants* (License Renewal GEIS) (NRC 2013a) and the analysis in this GEIS relies on that description to help establish the affected environment for continued storage. Sections 3.1 through 3.16 provide a general description of the affected at-reactor environment for each resource area. Descriptions of the typical facilities and activities that occur during continued storage are described in Chapter 2. The potential environmental impacts of continued storage at reactor sites are evaluated in Chapter 4.

3.1 Land Use

This section describes the affected environment in terms of land use associated with continued storage of spent fuel.

The general characteristics of nuclear power plants are described in Section 2.1.1 of this GEIS. Operating commercial nuclear power plant sites range in area from 34 ha (84 ac) to 5,700 ha (14,000 ac) (NRC 2013a). Nuclear power plant sites are zoned for industrial use with land requirements generally amounting to 40 to 50 ha (100 to 125 ac) for the reactor-containment building, auxiliary buildings, cooling system structures, administration and training offices, and other facilities (e.g., switchyards, security facilities, and parking lots). Areas disturbed during construction of the power plant generally were returned to prior uses when construction was completed. Other land commitments include transmission line right-of-ways and cooling lakes (if used) (NRC 2013a).

Affected Environment

As described in the License Renewal GEIS (NRC 2013a), areas surrounding nuclear power plant sites typically consist of flat to rolling countryside in wooded or agricultural areas. Information on land cover within 8 km (5 mi) of commercial nuclear power plants is summarized in Table 3.2–1 of the License Renewal GEIS (NRC 2013a). Most of the land cover near plants is undeveloped land (forest, wetlands, herbaceous cover, and shrub/scrub land), agricultural land, or open water. U.S. Nuclear Regulatory Commission (NRC) regions and the location of operating reactors within the United States are shown in Figure 3-1. In Region I (Northeast) and Region II (Southeast), more than 80 percent of land cover surrounding most plants is open water, forest, wetlands, and agricultural. Power plants in Region III (northern Midwest) are mostly surrounded (approximately 80 percent) by agricultural land, open water, and forests. In Region IV (West and southern Midwest), more than 90 percent of land cover surrounding most plants is agricultural land, shrub/scrub land, open water, forest, herbaceous cover, and wetlands (NRC 2013a).

U.S. Operating Commercial Nuclear Power Reactors

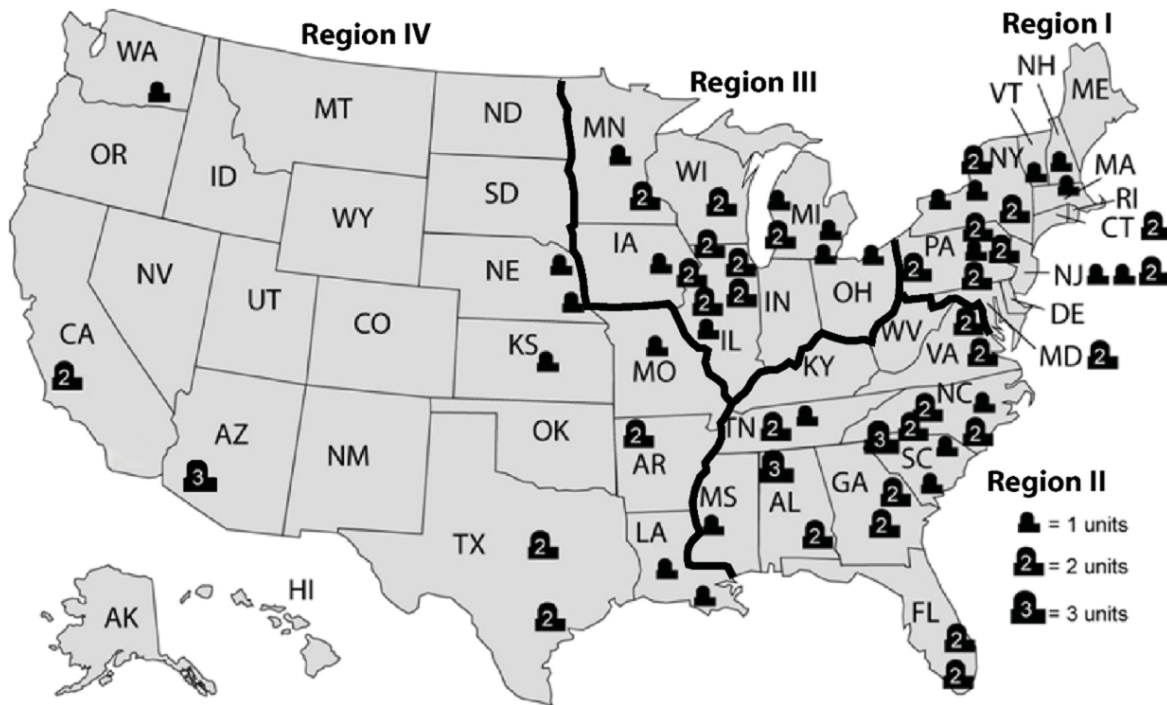

Figure 3-1. Map of NRC Regions Showing Locations of Operating Reactors (NRC 2013b)

Nuclear power plants and their ISFSIs are located in a range of political jurisdictions including towns, townships, service districts, counties, parishes, and states. The distances of plants from metropolitan and residential areas vary among sites. Most sites are not very remote (i.e., they are not more than about 32 km [20 mi] from a community of 25,000 people or 80 km [50 mi] from a community of 100,000 people). State, Federal, and Native American lands are present to various extents within the 80-km (50-mi) radius of power plants (NRC 2013a).

During the period from 1960 to 1980, with utilities and local government actively encouraging growth (Metz 1983), commercial and industrial land uses tended to expand within the 16-km (10-mi) radius around nuclear power plants at the expense of agriculture (NRC 2013a). In some instances, the roads and water lines built for plant purposes encouraged residential and industrial growth. As described in Section 2.1, the distance of the nearest resident to a nuclear power plant and ISFSI is typically about 0.4 km (0.25 mi). Recently, local jurisdictions have adopted comprehensive land use or master plans to control residential and commercial growth and preserve agricultural land around nuclear power plants (NRC 2013a).

Commercial nuclear power plant sites are owned and maintained by investor-owned utilities or merchant generators (i.e., independent power producers) that operate the associated power plants. While many plant owners use the land solely for generating electricity, some owners allow other uses for the land. Some plant owners lease land for agricultural (farming) and forestry production, permit cemetery and historical site access, and designate portions of their sites for recreation, management of natural areas, and wildlife conservation. As a result of security concerns after September 11, 2001, licensees have implemented improved site security measures, such as upgraded fencing, reduced site access, and increased signage detailing site access and restrictions (NRC 2013a).

Spent fuel pools are housed in shield buildings at nuclear power plants with boiling water reactors or in fuel buildings at plants with pressurized water reactors (NRC 2013a). Continued storage in spent fuel pools would require only the building housing the spent fuel pool and any cooling system infrastructure that keeps the spent fuel cool. Land requirements for spent fuel pools are small in comparison to the total nuclear power plant site area.

At most operating nuclear power plants, ISFSIs have been constructed to provide increased spent fuel storage because the spent fuel pools have reached capacity. The majority of ISFSIs are located at licensed nuclear power plant sites. Land requirements for ISFSIs (either at operating or decommissioned power plants) are small in comparison to the total power plant site area. Spent fuel storage under either a general license or a site-specific license at an operating reactor consists of the casks, a cask transfer system (i.e., cranes and mobile equipment necessary to move the casks), and reinforced concrete pads on which the casks are placed (NRC 1989). Table 3-1 provides comparisons of land area needed for ISFSIs at various nuclear power plants in contrast to the total land area of power plant sites.

Table 3-1. Land Area Characteristics of Operating Nuclear Power Plants with Site-Specific ISFSI Licenses

Plant	Total Site Area ha (ac)	Land Area Developed for ISFSI ha (ac)	Land Area of Concrete Pad(s) ha (ac)
Calvert Cliffs	843 (2,108)	2.4 (6)	0.2 (0.5)
Diablo Canyon	304 (760)	1.6–2 (4–5)	0.48 (1.2)
Surry	336 (840)	6 (15)	0.2 (0.5)
H.B. Robinson	2,408 (6,020)	0.06 (0.15)	0.016 (0.04)
North Anna	721 (1,803)	4 (10)	0.2 (0.5)
Oconee	204 (510)	1.2 (3)	0.16 (0.4)
Prairie Island	224 (560)	4 (10)	0.16 (0.4)

Sources: NRC 2012a; 2009a; 2008; 2005a,b; 2003; 1992

3.2 Socioeconomics

This section describes the general socioeconomic factors that could be directly or indirectly affected by continued storage. For the GEIS, the NRC assumes that all nuclear power plant sites have constructed ISFSIs by the end of a reactor’s licensed life for operation. Further, by this time, the socioeconomic effects of reactor operations have become well established because regional socioeconomic conditions will have adjusted to the presence of the nuclear power plant. In addition, local communities will have adjusted to fluctuations in workforce caused by regularly scheduled refueling and maintenance outages. Changes in employment and tax payments caused by the transition from reactor operations to decommissioning, and the continued storage of spent fuel, can have a direct and indirect effect on public services and housing demand, as well as traffic volumes in the region around each nuclear power plant site.

In general, nuclear power plant sites in the United States are located in one of two broad regional economic settings: rural or semi-urban. Rural areas have relatively simple economies that are based primarily on agricultural activity (NRC 2013a). Rural economies have smaller, less diversified labor markets that are often composed of lower-paying occupations requiring less skill (NRC 2013a). Examples of nuclear power plant sites located in rural environments include Diablo Canyon, Grand Gulf, Oconee, Peach Bottom, Susquehanna, Three Mile Island, and Wolf Creek. Semi-urban areas have more complex economic structures, containing a wider range of industries, with larger and more diverse labor markets (NRC 2013a). Examples of power plant sites in semi-urban areas include Indian Point, Limerick, Millstone, and Palo Verde.

For the purposes of this GEIS, the socioeconomic region of influence is defined by where spent fuel storage workers and their families reside, spend their income, and use their benefits, thereby directly and indirectly affecting the economic conditions of the region. Local and regional communities provide the people, goods, and services needed to support spent fuel

storage operations. Spent fuel storage operations, in turn, provide wages and benefits for people and dollar expenditures for goods and services.

The NRC has prepared several environmental assessments (EAs) for constructing and operating at-reactor ISFSIs. A review of these EAs found that the construction workforce for an ISFSI ranged from approximately 20 to 60 workers for approximately 1 year (NRC 1991a, 2003, 1985). In most cases, the construction workforce was comprised of locally available construction workers and existing power plant operations and security personnel. Since most ISFSIs were constructed during the licensed life of the reactor (including renewed license periods), most reactor licensees added a small number of additional workers (i.e., fewer than three workers) to support ISFSI operations (NRC 1985, 1988, 1991b). No additional workers were required to maintain or monitor continued ISFSI operations for license renewal (NRC 2005a,b, 2009a, 1991a, 2012a).

The number of operations workers at a nuclear plant decreases as the power plant transitions from reactor operations to decommissioning. Compared to the number of workers needed to support nuclear power plant operations (i.e., 600 to 2,400 workers [NRC 2013a]), the storage of spent fuel requires far fewer workers, from 20 to 85 workers. In contrast, decommissioning activities require approximately 100 to 200 workers (NRC 2002). The number of operations workers required for continued storage would depend on current storage operations activities at any given site (e.g., ISFSI and spent fuel pool transfer operations). As noted in Chapter 1 of this GEIS, the environmental impacts of decommissioning are not considered to be part of continued storage.

3.2.1 Employment and Income

Regional socioeconomic conditions associated with continued storage can vary depending on the location of the at-reactor storage site and the size of the storage workforce. Impacts associated with reactor shutdown and decommissioning are discussed with respect to cumulative impacts in Chapter 6 of this GEIS. Some systems that were used during reactor operations would remain in operation to ensure spent fuel pool cooling prior to the transfer of spent fuel from the pool to an ISFSI. After reactor operations cease, a reduced workforce would maintain and monitor the spent fuel pool and ISFSI. The workforce would be further reduced once all spent fuel is transferred to the ISFSI. Workforce numbers would vary from site to site. Fewer than 20 full-time employees monitor and maintain the spent fuel at GEH Morris, an away-from-reactor spent fuel pool storage facility (NRC 2004). In 2005, the Electric Power Research Institute and Maine Yankee Atomic Power Company prepared a report that provides detailed information on the decommissioning of Maine Yankee Atomic Power Station (EPRI and Maine Yankee 2005). At Maine Yankee, approximately 85 workers completed fuel transfer from the spent fuel pool to the ISFSI (EPRI and Maine Yankee 2005). After fuel transfer was completed, overall staffing at Maine Yankee was reduced further (EPRI and Maine Yankee 2005). Currently, Maine Yankee maintains a staff of 30 to 35 workers, which consists of operations and

Affected Environment

security personnel (MYAPC 2013). In contrast, at Fort St. Vrain, the licensee estimated that ten workers were needed for ISFSI operations (NRC 1991a).

3.2.2 Taxes

Tax payments to local communities vary widely and the magnitude of tax payments depends on a number of factors including the State tax laws and established tax payment agreements with local tax authorities. These tax payments, whether occurring in rural or semi-urban areas, provide support for public services at the local level (NRC 2013a). After termination of reactor operations, property tax payments would continue to provide revenue, albeit at a reduced rate, for State and local governments to spend on education, public safety, local government services, and transportation. For example during plant operations, Maine Yankee paid approximately \$12 million a year to the Town of Wiscasset. Following plant shutdown, the town initially agreed to a reduction in taxes to approximately \$6.1 million. Then, subsequent 2-year agreements were reached, and the annual tax liability was reduced to approximately \$1 million (EPRI and Maine Yankee 2005). For the 2012–2013 tax year, Maine Yankee paid approximately \$1,003,000 in property taxes and fees (MYAPC 2013). Portland General Electric, the licensee for the decommissioned Trojan site, which stopped electrical generation in November 1992, has maintained an at-reactor ISFSI and paid \$1,075,228.77 in property taxes for the 2012 tax year (Columbia County 2013). Pacific Gas and Electric, the licensee for Humboldt Bay, which shutdown in July 1976, has maintained an at-reactor spent fuel pool and paid \$1,951,266 in property taxes to Humboldt County for the 2012–2013 tax year (PG&E 2012). Connecticut Yankee Atomic Power Company, the licensee for Haddam Neck, which shut down in December 1996, paid approximately \$1,200,000 in property taxes for the 2012 tax year to the town of Haddam (CYAPC 2012).

3.2.3 Demography

Nuclear power plants sites and their associated spent fuel pools and ISFSIs are located in a range of political jurisdictions (e.g., towns, townships, service districts, counties, parishes, Native American lands, and states). More than 50 percent of the sites have a population density within an 80-km (50-mi) radius of fewer than 77 persons/km² (200 persons/mi²). In general, the nearest resident to a nuclear power plant is approximately 0.4 km (0.25 mi) (NRC 2013a). Demographic characteristics vary in the region around each nuclear power plant site and may be affected by the remoteness of the nuclear plant to regional population centers (NRC 2013a).

Many communities have transient populations associated with regional tourist and recreational activities, weekend and summer homes, or populations of students who attend regional colleges and other educational institutions. For example, nuclear power plant sites located in coastal regions, such as D.C. Cook and Palisades on Lake Michigan, Oyster Creek on the New Jersey shore north of Atlantic City, and Diablo Canyon north of Avila Beach, have summer, weekend,

and retirement populations and a range of recreational and environmental amenities that attract visitors from nearby metropolitan population centers (NRC 2013a). The regions around Vermont Yankee and Diablo Canyon power stations attract visitors seeking outdoor recreational activities for camping, skiing, and hiking in nearby state parks (NRC 2013a, 2003).

In addition to transient populations, farms and factories in rural communities often employ migrant workers on a seasonal basis. For example, berry production near the D.C. Cook and Palisades Nuclear Plants is a local agricultural activity that employs a sizable migrant labor force in the summer (NRC 2013a).

3.2.4 Housing

Housing markets near nuclear power plant sites, including the spent fuel pools and associated ISFSIs, vary considerably, with wide ranges in the number of housing units, vacancy rates, and the type and quality of housing (NRC 2013a). Although housing demand may be temporarily affected by the number of workers employed at a nuclear power plant site (NRC 2013a), actual housing choices are not likely to be affected by the presence of a nuclear power plant or construction or operation of an ISFSI (NRC 2002). Rather, housing demand and choices are more likely to be in response to housing prices and commutes to a nearby urban area (NRC 2002). Nuclear power plants located in rural communities have relatively small housing markets (i.e., low housing availability), stable housing prices, lower median house values, and moderate and stable vacancy rates. In semi-urban regions, housing markets are likely to change more rapidly with population growth near metropolitan areas (NRC 2013a).

3.2.5 Public Services

Licensees of nuclear power plant sites pay taxes to local and State governments. Revenues from these tax payments support public services at local levels (NRC 2013a). Changes in employment and tax payments caused by the transition from reactor operations to decommissioning and continued storage can have a direct and indirect effect on public services in the region around each nuclear power plant site. Although the most important source of revenue for local communities are property taxes, other sources of revenue include levies of electricity output and direct funding for local educational facilities and programs. As discussed in Section 3.2.2, after termination of reactor operations, property tax payments would continue to provide revenue, albeit at a reduced rate, for State and local governments to spend on public services (e.g., education, public safety, local government services, and transportation).

3.2.6 Transportation

Local and regional transportation networks and traffic volumes in the vicinity of nuclear power plants and associated spent fuel pools and ISFSIs vary considerably depending on the regional population density, location, size of local communities, and the nature of economic development

patterns (NRC 2013a). For continued storage, it is anticipated that roadways used during plant operations would continue to be used for access to the ISFSI after reactor ceases operation. In both rural and semi-rural locations most sites have only one access road, which may experience congestion at peak travel times (NRC 2013a). For further information on transportation networks see Section 3.12.

3.3 Environmental Justice

This section describes the affected environment in the vicinity of at-reactor spent fuel storage sites with respect to environmental justice factors that could occur during continued storage. The environmental justice analysis assesses the potential for disproportionately high and adverse human health or environmental effects on minority and low-income populations that could result from continued storage.

Under Executive Order 12898 (59 FR 7629), Federal agencies are responsible for identifying and addressing potential disproportionately high and adverse human health and environmental impacts on minority and low-income populations. Environmental justice refers to a Federal policy implemented to ensure that minority, low-income, and tribal communities historically excluded from environmental decision-making are given equal opportunities to participate in decision-making processes. In 2004, the Commission issued a Policy Statement on the Treatment of Environmental Justice Matters in NRC Regulatory and Licensing Actions (69 FR 52040), which states “The Commission is committed to the general goals set forth in Executive Order 12898, and strives to meet those goals as part of its National Environmental Policy Act (NEPA) review process” (NRC 2013a).

Executive Order 12898, Federal Actions to Address Environmental Justice in Minority Populations and Low-Income Populations

“Each Federal agency, whenever practicable and appropriate, shall collect, maintain, and analyze information assessing and comparing environmental and human health risks borne by populations identified by race, national origin, or income. To the extent practical and appropriate, Federal agencies shall use this information to determine whether their programs, policies, and activities have disproportionately high and adverse human health or environmental effects on minority populations and low-income populations” (59 FR 7629).

The Council on Environmental Quality (CEQ) provides the following definitions to consider when conducting environmental justice reviews within the framework of NEPA, in *Environmental Justice: Guidance under the National Environmental Policy Act* (CEQ 1997):

- **Disproportionately High and Adverse Human Health Effects**—Adverse health effects are measured in risks and rates that could result in latent cancer fatalities, as well as other fatal or nonfatal adverse impacts on human health. Adverse health effects may include bodily impairment, infirmity, illness, or death. Disproportionately high and adverse human health

effects occur when the risk or rate of exposure to an environmental hazard for a minority or low-income population is significant (as employed by NEPA) and appreciably exceeds the risk or exposure rate for the general population or for another appropriate comparison group.

- **Disproportionately High and Adverse Environmental Effects**—A disproportionately high environmental impact that is significant (as employed by NEPA) refers to an impact or risk of an impact on the natural or physical environment in a low-income or minority community that appreciably exceeds the environmental impact on the larger community. Such effects may include ecological, cultural, human health, economic, or social impacts. An adverse environmental impact is an impact that is determined to be both harmful and significant (as employed by NEPA). In assessing cultural and aesthetic environmental impacts, impacts that uniquely affect geographically dislocated or dispersed minority or low-income populations or American Indian tribes are considered.
- **Minority individuals**—Individuals who identify themselves as members of the following population groups: Hispanic or Latino, American Indian or Alaska Native, Asian, Black or African American, Native Hawaiian or Other Pacific Islander, or two or more races meaning individuals who identified themselves on a Census form as being a member of two or more races, for example, Hispanic and Asian.
- **Minority populations**—Minority populations are identified when (1) the minority population of an affected area exceeds 50 percent or (2) the minority population percentage of the affected area is meaningfully greater than the minority population percentage in the general population or other appropriate unit of geographic analysis. Minority populations may be communities of individuals living in close geographic proximity to one another, or they may be a geographically dispersed or transient set of individuals, such as migrant workers or American Indians, who, as a group, experience common conditions with regard to environmental exposure or environmental effects. The appropriate geographic unit of analysis may be a political jurisdiction, county, region, or State, or some other similar unit that is chosen so as not to artificially dilute or inflate the affected minority population.
- **Low-income population**—Low-income population is defined as individuals or families living below the poverty level as defined by the U.S. Census Bureau's Current Population Reports, Series P-60 on Income and Poverty (USCB 2007). Low-income populations may be communities of individuals living in close geographic proximity to one another, or they may be a set of individuals, such as migrant workers, who, as a group, experience common conditions.

Consistent with the NRC's Policy Statement (69 FR 52040), affected populations are defined as minority and low-income populations who reside within an 80-km (50-mi) radius of a nuclear power plant site. Data on low-income and minority individuals are usually collected and analyzed at the census tract or census block group level (NRC 2013a).

Affected Environment

For the continued storage of spent fuel, the NRC will comply with Executive Order 12898 (59 FR 7629) through implementation of its NEPA requirements in Title 10 of the *Code of Federal Regulations* (CFR) Part 51 by considering impacts to minority and low-income populations in this GEIS. It should be noted, however, that the rulemaking is not a licensing action; it does not authorize the initial or continued operation of any nuclear power plant, and it does not authorize storage of spent fuel. Neither this rulemaking nor this GEIS identify specific sites for NRC licensing actions that would trigger a site-specific assessment.

This GEIS describes the potential human health and environmental effects to minority and low-income populations associated with continued storage of spent fuel at both at- and away-from-reactor ISFSIs. The NRC has determined that, for the purposes of this analysis, a generic analysis of the human health and environmental effects of continued storage on minority and low-income populations is possible.

For site-specific licensing actions, the NRC addresses environmental justice matters by (1) identifying the location of minority and low-income populations that may be affected by long-term storage of spent fuel at nuclear power plant sites, (2) determining whether there would be any potential human health or environmental effects to these populations and special-pathway receptors, and (3) determining if any of the effects may be disproportionately high and adverse. The NRC has and will continue to prepare a site-specific environmental analysis, including an assessment of potential impacts to minority and low-income populations prior to any future NRC licensing action.

As discussed in Section 3.2 of this GEIS, nuclear power plant sites in the United States are located in one of two broad regional economic settings: rural or semi-urban. Demographic characteristics vary in the region around each nuclear power plant site and may be affected by the remoteness of the nuclear plant to regional population centers (NRC 2013a). Nuclear power plants located in both rural and semi-urban areas can have varying concentrations of minority and low-income communities. Prairie Island Nuclear Generating Plant near Red Wing, Minnesota, is an example of a facility in a rural environment. The Prairie Island Indian Community is located immediately next to the Prairie Island Nuclear Generating Plant and is the closest minority population and American Indian community to spent fuel storage pools and an ISFSI.

Subsistence Consumption of Fish and Wildlife

Section 4-4 of Executive Order 12898 (59 FR 7629) directs Federal agencies, whenever practical and appropriate, to collect and analyze information on the consumption patterns of populations that rely principally on fish or wildlife for subsistence and to communicate the risks of these consumption patterns to the public. In this GEIS, the NRC considered whether there were any means for minority or low-income populations to be disproportionately affected by examining impacts to American Indians, Hispanics, migrant workers, and other traditional

lifestyle special-pathway receptors. Special pathways take into account the levels of radiological and nonradiological contaminants in native vegetation, crops, soils and sediments, groundwater, surface water, fish, and game animals on or near power plant sites that have spent fuel storage pools and ISFSIs.

The special-pathway-receptors analysis is an important part of the environmental justice analysis because consumption patterns may reflect the traditional or cultural practices of minority and low-income populations in an area, such as migrant workers or Native Americans. Traditional use of an area can be indicative of properties or resources that are historically significant for a living community to maintain its cultural heritage. These places—called traditional cultural properties—are discussed in Section 3.11 of this GEIS. For example, in the Prairie Island Nuclear Generating Plant license renewal review, the Prairie Island Indian Community provided the NRC information about the traditional use of Prairie Island as a summer encampment for fishing, hunting, gathering medicines and foods, and raising crops. During the review, the Prairie Island Indian Community also expressed concern about native plants on Prairie Island being displaced by invasive species and human health impacts associated with the use of plants that are culturally significant to the Prairie Island Indian Community.

Operating nuclear power plants must have a comprehensive radiological environmental monitoring program to assess the impact of site operations on the environment. During plant operations, nuclear power plant operators collect samples from aquatic pathways (e.g., fish, surface water, and sediment) and terrestrial pathways (e.g., airborne particulates, radioiodine, milk, food products, crops, and direct radiation). Contaminant concentrations found in native vegetation, crops, soils, sediment, surface water, fish, and game animals in areas surrounding nuclear power plants are usually quite low (i.e., at or near the threshold of detection) and are seldom above background levels (NRC 2013a).

3.4 Climate and Air Quality

This section describes the local and regional climate, air quality, and sources of greenhouse gas emissions during continued storage.

3.4.1 Climate

This section describes the climate near spent fuel pools and at-reactor ISFSIs. For this resource area, the License Renewal GEIS (NRC 2013a) provides the baseline description of the affected environment at the start of continued storage. As described in the License Renewal GEIS, weather conditions at nuclear power plant sites vary depending on the year, season, time of day, and site-specific conditions, such as whether the site is located near coastal zones or in or near terrain with complex features (e.g., steep slopes, ravines, and valleys). These

Affected Environment

conditions can be generally described by climate zones according to average temperatures. On the basis of temperature alone, there are three major climate zones: polar, temperate, and tropical. Within each of the three major climate zones, there are marine and continental climates. Areas near an ocean or other large body of water have a marine climate. Areas located within a large landmass have a continental climate. Typically, areas with a marine climate receive more precipitation and have a more moderate climate. A continental climate has less precipitation and a greater range in climate. Regional or localized refinements in climate descriptions and assessments can be made by considering other important climate variables and climate-influencing geographic variables, such as precipitation, humidity, surface roughness, proximity to oceans or large lakes, soil moisture, albedo (i.e., the fraction of solar energy [shortwave radiation] reflected from the Earth back into space), snow cover, and associated linkages and feedback mechanisms. Localized microclimates can be defined by considering factors such as urban latent and sensible heat flux and building-generated turbulence. Both national and regional maximum and minimum average annual temperature and precipitation climates over the 30 years from 1971 through 2000 are summarized in Section D.2 in Appendix D of the License Renewal GEIS (NRC 2013a).

The frequency and intensity of tornadoes, straight winds, and wind-borne missiles are a consideration in the design of both spent fuel storage pools and dry cask storage systems. Natural phenomena hazards, including design bases for high winds and wind-borne missiles are considered in the design bases of spent fuel storage facilities, as discussed in Section 4.18.

3.4.2 Greenhouse Gases

Based on assessments by the Global Climate Research Program (GCRP) and the National Academy of Sciences' National Research Council, the U.S. Environmental Protection Agency (EPA) determined that potential changes in climate caused by greenhouse gas (GHG) emissions could endanger public health and welfare (74 FR 66496). The EPA indicated that, while ambient concentrations of GHGs do not cause direct adverse health effects (such as respiratory or toxic effects), public health risks and impacts can result indirectly from changes in climate. Based on the EPA's determination, the NRC recognizes that GHGs contribute to climate change, climate change can affect health and the environment, and mitigation actions are necessary to reduce impacts. The NRC considers carbon dioxide and other GHG emissions in its environmental reviews, and includes consideration of emissions from construction and operation of a facility (NRC 2009b). NRC guidance (NRC 2013c) also addresses consideration of GHGs and carbon dioxide in environmental reviews for new power reactors. Historically, long-term carbon dioxide levels extending back 800,000 years have ranged between 170 and 300 parts per million; the GCRP estimates that present-day carbon dioxide concentrations are about 400 parts per million, higher than at any time in at least the last 1 million years (GCRP 2014).

According to GCRP estimates, carbon dioxide levels at the end of the century will range between 420 and 935 parts per million (GCRP 2014). This corresponds to a projected increase in average temperature through the end of the century of between 2.8° to 5.5°C (5° to 10°F) for a higher GHG emissions scenario, which assumes no efforts to reduce GHG emissions (GCRP 2014). The GCRP also presented the projected change in precipitation from the “recent past” (1970 to 1999) through the end of the century (around 2100). Generally, the GCRP forecasts that future precipitation will increase in northern areas (especially the Northeast and Alaska), while southern areas, particularly the Southwest, will become drier (GCRP 2014).

Three EPA Air Quality Designations

Nonattainment: Any area that does not meet (or that contributes to ambient air quality in a nearby area that does not meet) the national primary or secondary ambient air quality standard for the pollutant.

Attainment: Any area that meets the national primary or secondary ambient air quality standard for the pollutant.

Unclassifiable: Any area that cannot be classified on the basis of available information as meeting or not meeting the national primary or secondary ambient air quality standard for the pollutant.

3.4.3 Criteria Pollutants

The EPA has set National Ambient Air Quality Standards (NAAQS) (40 CFR Part 50) for six criteria pollutants, including sulfur dioxide, nitrogen dioxide, carbon monoxide, ozone, particulate matter (PM; PM₁₀, and PM_{2.5}), and lead. Primary NAAQS specify maximum ambient (outdoor air) concentration levels of the criteria pollutants with the aim of protecting public health with an adequate margin of safety.¹ Secondary NAAQS specify maximum concentration levels with the aim of protecting public welfare.² States can have their own State Ambient Air Quality Standards. State Ambient Air Quality Standards must be at least as stringent as the NAAQS, and they can include standards for additional pollutants. If a State has no standard corresponding to one of the NAAQS, then the NAAQS apply. The EPA’s Tribal Authority Rule (63 FR 7254) also identifies provisions of the Clean Air Act that treat eligible Federally recognized Tribes as States.

The EPA generally designates a nonattainment area based upon air quality monitoring data or modeling studies that show the area violates or contributes to violations of the national

¹Based on EPA regulations, primary (health-based) standards are requisite to protect public health with an “adequate margin of safety.” The margin of safety is intended to address uncertainties associated with inconclusive evidence, and to provide a reasonable degree of protection against hazards that research has not yet identified.

²Based on EPA regulations, secondary (welfare-based) standards are requisite to protect the “public welfare” from any known or anticipated adverse effects. Welfare effects include “effects on soils, water, crops, vegetation, man-made materials, animals, wildlife, weather, visibility and climate...” (Hassett-Sipple 2011).

Affected Environment

standard. The area also is referred to as an air quality control region, which the EPA designates for air quality management purposes and which typically consists of one or more counties. The EPA designates the area as attainment/unclassifiable if the area meets the standard or expects to meet the standard despite a lack of monitoring data or modeling studies. After the air quality in a nonattainment area improves so that it no longer violates or contributes to violations of the standard and the State or Tribe adopts an EPA-approved plan to maintain the standard, the EPA can re-designate the area as attainment. These areas are known as maintenance areas. In the License Renewal GEIS (NRC 2013a), the NRC identified operating plants located within or adjacent to counties with designated nonattainment areas. The EPA periodically reviews ambient pollution concentrations throughout the country and reclassifies the attainment status of areas. Attainment designation status for areas is presented in 40 CFR Part 81.

Each State develops an implementation plan that includes a strategy for attaining or maintaining the NAAQS, modeling that demonstrates attainment or maintenance, and various rules, regulations, and programs that provide the necessary air pollutant emissions reductions. On tribal lands, Federally recognized Indian tribes can develop their own tribal implementation plans, similar to State implementation plans. If a State or Tribe fails to submit a required plan, the EPA can promulgate a plan known as a Federal implementation plan. In accordance with Section 176(c) of the Clean Air Act and the General Conformity Regulations (40 CFR Part 51 and Part 93), the NRC must analyze its licensing actions to ensure that its Federal action conforms to any applicable implementation plan. Conformity determinations are required when a department, agency, or instrumentality of the Federal government engages in, supports in any way or provides financial assistance for, licenses or permits, or approves any activity to ensure that the activity conforms to an applicable implementation plan. Currently, the General Conformity Regulations (40 CFR Part 51 and Part 93) apply to all Federal actions that are taken in nonattainment or maintenance areas.

The NRC will evaluate and document the need for a conformity determination for the activities within its authority that require an NRC license. These evaluations are completed as part of licensing actions involving new reactors, reactor license renewal, and any specifically licensed ISFSI. Most NRC licensing actions involve emissions well below *de minimis* levels established by the EPA in the General Conformity Regulations (e.g., 100 tons per year for nitrogen oxide emissions [a precursor to ozone] in maintenance areas). As described further in Chapter 4, emissions of criteria pollutants during continued storage are likely to remain below *de minimis* levels at all sites, and a general conformity determination would not be required.

3.5 Geology and Soils

This section describes the geology and soils that have the potential to be affected by continued storage of spent fuel.

The geologic environment of a nuclear power plant consists of the regional physiography, tectonic setting, and composition and physical properties of the bedrock and sedimentary strata underlying the site. Geologic hazards are also a condition of the geologic environment, including faulting and seismicity (NRC 2013a). Seismic hazards are the most ubiquitous of the geologic hazards, and almost all parts in the United States are subject to some potential for earthquake-induced vibrations. The likelihood and intensity of earthquake-induced vibratory ground motion at reactors depend on two factors. First, the number, frequency, and location of earthquakes depend on the site's tectonic setting, tectonic activity, and nature of the seismic sources. Second, the physical characteristics of bedrock and soils beneath the site determine how earthquake energy is attenuated or amplified as it travels from the earthquake sources to the site. Both factors are integral to the development of the earthquake hazard assessments that form the bases for the seismic design of spent fuel pools and dry cask storage systems. Natural phenomena hazards in the design basis of spent fuel storage facilities, including seismic design, are addressed in Section 4.18, "Environmental Impacts of Postulated Accidents."

The general characteristics of nuclear power plants are discussed in Section 2.1.1 of this GEIS, in the License Renewal GEIS, and in environmental statements and environmental impact statements prepared for initial construction and operation of nuclear power plants. All safety-related structures (e.g., seismic category 1 structures) at nuclear power plants are founded either on competent natural or engineered strata to ensure that no safety-related facilities are constructed in potentially unstable materials (NRC 2013a).

During construction of nuclear power plants, soil is disturbed for buildings, roads, parking lots, underground utilities (including cooling-water system intake and discharge systems), aboveground utility structures (including transmission lines), cooling towers, and other structures (NRC 2013a), including at-reactor ISFSIs, which are usually constructed during nuclear power plant operations. Nuclear power plant sites range in size from 34 ha (84 ac) at the San Onofre plant in California to 5,700 ha (14,000 ac) at the Clinton plant in Illinois. At-reactor ISFSIs range in size from 0.06 to 6 ha (0.15 to 15 ac). The proportion of land that remains undisturbed or undeveloped by construction activities varies from site to site.

Soils form over time in response to weathering and erosion of parent materials (underlying bedrock or sediments), and as soils mature, they develop distinct horizons or layers that have varying properties and potential uses. Across the United States, soils have a variety of compositions and related physical properties, depending on the local geologic conditions and climate. The degree of infiltration and the relative movement of groundwater or contaminants through the soils depend on these physical properties.

The geologic resources in the vicinity of each nuclear plant and at-reactor ISFSI vary with the location and land-use activities. For example, where mining operations occur (e.g., sand and gravel pit operations or quarrying for crushed stone), there is little if any interaction between plant operations and local mining industries. However, some nuclear plants may purchase

materials for landscaping and site construction from local sources. Commercial mining or quarrying operations are not allowed within nuclear power plant boundaries (NRC 2013a).

3.6 Surface-Water Quality and Use

This section describes the surface-water use and quality that could be affected by the continued storage of spent fuel in spent fuel pools and at-reactor ISFSIs.

Because nuclear reactor operations rely predominantly on water for cooling, most nuclear power plant sites are located near reliable sources of water. These sources are often surface waterbodies such as rivers, lakes, oceans, bays, and reservoirs and other man-made impoundments (NRC 2013a). The single exception is the Palo Verde Nuclear Generating Station in Arizona, which uses treated municipal wastewater for cooling water. Of the sites in the United States that contain NRC-licensed nuclear power plants, 32 are located near rivers, 22 near lakes and reservoirs, 5 near oceans, and 5 near estuaries and bays. These waterbodies form part of the affected environment for storage of spent fuel in spent fuel pools and at-reactor ISFSIs. Local drainage features at and near nuclear power plant sites, such as creeks and small streams, provide avenues for surface-water movement and interaction with surface waterbodies. Depending on regional precipitation regimes, local topography, and drainage patterns, operation of spent fuel pools and at-reactor ISFSIs may affect the availability and quality of these nearby surface-water resources.

Provisions of the Clean Water Act regulate the discharge of pollutants into waters of the United States. Discharges of cooling water and other plant wastewaters are monitored through the National Pollutant Discharge Elimination System (NPDES) program administered by the EPA, or, where delegated, individual States. An NPDES permit is developed with two levels of controls: (1) technology-based limits and (2) water quality-based limits. The technology-based limits applicable to nuclear power-generating plants are in 40 CFR Part 423. NPDES permit terms may not exceed 5 years (unless administratively continued), and the applicant must reapply at least 180 days prior to the permit expiration date. The NPDES permit contains requirements that limit the flow rates and pollutant concentrations that may be discharged at permitted outfalls. Biocides and other contaminants in discharged cooling waters are governed by NPDES permit restrictions to reduce the potential for toxic effects on nontargeted organisms (e.g., native mussels and fish). NPDES permits impose temperature limits for effluents (which may vary by season) and/or a maximum temperature increase above the ambient water temperature (referred to as “delta-T,” which also may vary by season). Other aspects of the permit may include the compliance measuring location and restrictions against plant shutdowns during winter to avoid drastic temperature changes in surface waterbodies. The permit also may include biological monitoring parameters that are primarily associated with the discharge of cooling water. The intake of cooling water from waters of the United States is regulated under Clean Water Act Section 316(b), and the thermal component of any effluent discharges from

power-generating plants may be regulated by either the applicable State water quality standard or by Clean Water Act Section 316(a).

Wastewater discharge is also covered through NPDES permitting, and it includes biochemical monitoring parameters. Conditions of discharge for each plant are specified in its NPDES permit issued by the State or EPA. Most plants have a stormwater management plan, with the parameter limits of the stormwater outfalls included in the NPDES permit. Plants also may have a spill prevention, control, and countermeasures plan that provides information on potential liquid spill hazards and the appropriate absorbent materials to use if a spill occurs.

In an effort to minimize or eliminate impacts to the water quality of receiving waterbodies, best management practices are typically included as conditions within NPDES permits. Best management practices are measures used to control the adverse stormwater-related effects of land disturbance and development. They include structural devices designed to remove pollutants, reduce runoff rates and volumes, and protect aquatic habitats. Best management practices also include nonstructural or administrative approaches, such as training to educate staff on the proper handling and disposal of potential pollutants.

After cessation of reactor operations at the nuclear power plant sites, water use would be reduced to spent fuel pool cooling, radiation protection for workers, maintenance, human consumption, and personal hygiene.

3.7 Groundwater Quality and Use

This section describes the groundwater use and quality that could be affected by the continued storage of spent fuel in spent fuel pools and at-reactor ISFSIs.

Groundwater, which has been used as a water supply source throughout recorded history, is found in the voids of unconsolidated geologic materials (e.g., sand and gravel), in fractures of consolidated rocks (e.g., sedimentary, metamorphic, igneous, and volcanic rocks), and in conduits/channels of carbonates (e.g., limestone and dolomites). Where groundwater can be found in the subsurface depends on the geologic history of an area. The quantity and quality of groundwater for domestic uses depends on site-specific conditions. Anthropogenic impacts may affect groundwater quality, but those impacts also are site-specific. Both unconfined and confined aquifers that can provide a potential water supply source for domestic use may exist beneath a nuclear power plant site. The type of aquifers and their properties at nuclear power plant sites are site-specific and can vary considerably.

In the eastern United States, most nuclear power plant sites are located in two large regional groundwater provinces: (1) the first is composed of the Atlantic and Eastern Gulf coastal plain, the Southeastern coastal plain, and the Gulf of Mexico coastal plain; and (2) the second is composed of the Central Glaciated and the Central Nonglaciated plains (Back et al. 1988). The

Affected Environment

first groundwater province, which extends from New Jersey south to Florida and west along the Gulf of Mexico, includes aquifers that have moderate to very high transmissivity values, moderate to high recharge rates, and moderate- to high-yield wells. In contrast, the second groundwater province, which includes the Great Lakes and upper Midwest, includes aquifers that have moderate to high transmissivity values, lower recharge rates, and low- to moderate-yield wells.

In addition, several nuclear power plant sites are located in the Piedmont and Blue Ridge and the Appalachian Plateau and Valley and Ridge groundwater regions (Back et al. 1988). Aquifers in the Piedmont and Blue Ridge region have low transmissivity values, and while recharge rates are moderate to high, typical wells have very low yields. By contrast, aquifers in the Appalachian Plateau and Valley and Ridge have moderate to high transmissivity values, moderate to high recharge rates, and low to moderate-yield wells.

Two of the four nuclear power plant sites located in the western United States use cooling water from the Pacific Ocean. These two nuclear power plants are located in the Pacific Coast Range region of California. The geologic complexity of this region creates diverse hydrogeologic conditions. Another power plant in the west uses cooling water from the Columbia River, which dissects the prolific bedded basalt aquifer system of the Columbia Lava Plateau, while the fourth, located in the Central Alluvial Basins of the arid desert southwest, uses treated municipal wastewater for cooling (Back et al. 1988).

Many of the nuclear power reactor sites in the United States that are adjacent to lakes, rivers, reservoirs, and engineered cooling ponds are constructed on unconsolidated stream, glacial, and lake deposits that host shallow, unconfined to semi-confined aquifers (Back et al. 1988). Where unconsolidated permeable deposits are thin or not inter-bedded with lower permeability sediments, local groundwater flow systems may be hydraulically connected to deeper, regional to sub-regional groundwater flow systems in underlying permeable unconsolidated deposits, coarse-grained sandstone, carbonate units with solution features, and folded or fractured crystalline rocks. Where shallow aquifers are immediately underlain by thick, impermeable shale or massive, unjointed carbonate strata, there is likely little or no hydraulic connection with deeper, regional groundwater flow systems.

Contaminants may enter an aquifer system and be transported with the hydraulic gradient. The direction and rate of contaminant transport will depend on the site-specific properties of the aquifer. For relatively permeable aquifers with a substantial hydraulic gradient, contaminants would be transported down-gradient quickly. For relatively permeable aquifers with a low hydraulic gradient, contaminants would move very slowly down-gradient. Typically, a contaminant plume would be elongated in the direction of the hydraulic gradient because transverse mixing (transverse dispersion) is much less than in the groundwater flow direction (longitudinal dispersion) (Todd 1960). For relatively low permeable aquifers, contaminants would move very slowly.

As noted in the License Renewal GEIS (NRC 2013a), leaks and spills during the licensed life for operation at reactors have resulted in groundwater and soil contamination. Industrial practices involving the use of solvents, heavy metals, or other chemicals and unlined wastewater lagoons have the potential to contaminate site groundwater, soil, and subsoil. Contamination is subject to State- and EPA-regulated cleanup and monitoring programs (NRC 2013a). In addition, radionuclides, particularly tritium, have been released to groundwater at many plants. Underground system leaks of process water also have been discovered in recent years at several plants. A description of spent fuel pool leaks at NRC-licensed facilities is included in Appendix E.

Because tritium travels through groundwater faster than most other radionuclides, tritium is generally the first radionuclide to be identified in groundwater after a radioactive spill or leak. Records as of December 2013 indicate that, at some time during their operating history, 45 nuclear power plant sites have had leaks or spills involving tritium concentrations in excess of the 20,000 pCi/L drinking water standard established in the Safe Drinking Water Act. Also as of December 2013, 17 sites are reporting tritium concentrations from a leak or spill in excess of 20,000 pCi/L onsite. However, no site is currently reporting tritium in excess of 20,000 pCi/L offsite, or in drinking water (NRC 2013d).

On June 17, 2011, the NRC issued the Decommissioning Planning Rule (76 FR 35512). This rule, through changes to the regulations at 10 CFR 20.1406 and 20.1501, requires licensees to "... minimize the introduction of significant residual radioactivity into the site, including the subsurface, and to perform radiological surveys to identify the extent of significant residual radioactivity at their sites, including the subsurface" (NRC 2012b). As a result, all currently operating NRC-licensed nuclear power plants and any nuclear power plant that may be built in the future are required to perform groundwater monitoring to determine the extent of any existing contamination and to aid in the timely detection of any future contamination. Timely detection of leakage will allow licensees to identify and repair leaks and employ mitigation measures, as necessary, to minimize or eliminate any environmental impacts that would result from leaks.

Licensees that have implemented a groundwater monitoring program consistent with the Nuclear Energy Institute Groundwater Protection Initiative are considered to have an adequate program for the purposes of the Decommissioning Planning Rule (NRC 2011). Additional discussion pertaining to groundwater monitoring can be found in Appendix E of this GEIS.

3.8 Terrestrial Resources

This section describes the general terrestrial resources that could be affected by continued storage of spent fuel in spent fuel pools and at-reactor ISFSIs. Terrestrial plant and animal

Affected Environment

communities found on land may be subject to potential effects associated with spent fuel storage facilities (wet storage in spent fuel pools or dry storage in casks).

Nuclear power plants (which include spent fuel pools) and associated ISFSIs (which are located on nuclear power plant sites) are sited in a wide variety of terrestrial habitat types from coastal to intermountain landscapes. Terrestrial habitats vary widely depending on their ecoregion or geographic location, especially in relation to the climate, landforms, and soil characteristics. Surrounding land uses and land forms (e.g., deserts and mountains) significantly influence the local and regional biodiversity and ecosystem. For example, an arid desert location is likely to have less biodiversity than a temperate rainforest. In addition, impacts at the local level in the immediate vicinity of nuclear power plants and associated at-reactor ISFSIs that have relatively intact, functioning ecosystems because of the lack of extensive development and disturbance would provide higher quality habitat and biodiversity as opposed to heavily industrialized areas where larger areas of habitat loss and disturbances decreases habitat quality and biodiversity.

For the purposes of this analysis, terrestrial ecological resources are described in terms of upland vegetation and habitats, lowland and wetland vegetation and habitats, and wildlife.

3.8.1 Upland Vegetation and Habitats

In general, upland terrestrial vegetation and habitats include habitats such as forests, grasslands, and shrublands as opposed to lowland areas. These habitats experience changes, called succession, within the vegetation communities in response to land-disturbing activities. The level of anthropogenic disturbance varies by land-use management activities (see Section 3.1). Typically, areas within the security fence at a nuclear power plant and associated ISFSI have been modified by construction and maintenance activities and are maintained as modified landscapes for operational and security purposes. Some of these areas could contain relatively undisturbed habitat. Disturbed habitats are characterized mainly by grasses, forbs, and shrubs that represent the early successional stage. A maintenance activity, such as mowing and herbicide or pesticide applications, limits the diversity and maturity of plant species that are present. After construction of nuclear power plants and during maintenance activities, non-native plant species and weeds often replace the naturally occurring vegetation, while natural forest or shrubland in various degrees of disturbance may be present outside the security fence (NRC 2013a). The affected habitats for at-reactor continued storage would be similar to habitats described in the License Renewal GEIS because spent fuel pools and at-reactor ISFSIs are located at the nuclear power reactor sites described in the License Renewal GEIS.

Several operational activities at nuclear power plants may have effects on upland vegetative communities and habitats. As described in License Renewal GEIS (NRC 2013a), terrestrial habitats near nuclear power plants can be subject to small amounts of radionuclides. Radionuclides, such as tritium, and other constituents in cooling-water systems, such as

biocides, that enter shallow groundwater can also be taken up by terrestrial plant species. Maintenance activities along nuclear power plant transmission line corridors (cutting vegetation and using herbicides) within the property boundary of a nuclear power plant can contribute to habitat fragmentation and affect the distribution of plant and animal species in areas near the corridors. Nuclear power plants' cooling towers may deposit water (and salt) droplets on vegetation and increase humidity in the area relatively close to the cooling towers during the period that the spent fuel pool is operated. In addition, heat dissipated during power plant operations by a combination of radiation, conduction, and convection can expose terrestrial habitats to elevated temperatures (NRC 2013a).

3.8.2 Lowland and Wetland Vegetation and Habitats

Lowlands along rivers, streams, and coastlines may include floodplains, riparian zones, and several types of wetlands (riverine, palustrine, lacustrine, estuarine, and marine) that support fish and wildlife. As of 2007, wetlands covered an average of 3 percent of the land area near nuclear power plants and at-reactor ISFSIs, as mapped by the National Wetland Inventory (FWS 2007). Wetlands exclude permanently flooded areas that occupy, on average, about 10 percent of the area within 8 km (5 mi) of nuclear power plants (NRC 2013a). Wetland vegetation is hydrophytic (i.e., able to withstand waterlogged conditions) whether anchored on relatively dry land or in standing water. Depending on the wetland type, vegetation can vary widely from flowering plants, grasses, shrubs (reeds, sedges, and rushes), ferns, and trees.

During the initial nuclear power plant license periods, wetlands and riparian communities near nuclear power plants were affected by construction and operation activities (e.g., maintaining power line corridors, dredging wetland sediments, and sediment disposal) that caused stormwater runoff, changes in vegetative plant community characteristics, altered hydrology, decreased water quality and quantity, and sedimentation. Some wetlands and riparian communities have been affected by nuclear power plant cooling systems that can increase the salinity of stream segments, increase water temperatures, and introduce contaminants to wetlands that receive groundwater discharge. However, wetlands have also been created at some power plants that use cooling ponds (NRC 2013a).

3.8.3 Wildlife

Terrestrial animals (i.e., land mammals, insects, birds, amphibians, and reptiles) in the vicinity of a nuclear power plant and associated ISFSI are typical of species found in a particular ecoregion and vary widely across the United States. The removal of vegetation during plant construction and operations have affected the habitat quality and, at some sites, reduced the available habitat by hundreds of acres. Wildlife biodiversity and ecological function in disturbed areas of nuclear power plant sites, including at-reactor ISFSIs, are different from those in undisturbed areas, in part because the wildlife communities supported by disturbed areas are different from those that undisturbed areas support (NRC 2013a). Disruptive human activities (e.g., noise, ground

Affected Environment

vibrations, mechanical equipment, vehicles, and physical obstructions) also repel animals that are less tolerant to such disturbances. At the beginning of continued storage, these disturbed and undisturbed areas will be identical to the areas that existed during operations.

Maintenance activities along nuclear power plant transmission line corridors within the property boundary of the plant, which will continue during continued storage, affect the distribution of plant and animal species in areas near the corridors and expose wildlife to nonionizing radiation exposure from transmission line electromagnetic fields (NRC 2013a).

Wildlife species that rely on and use the water resources at the reactor site will continue to be affected by continued storage. For example, the ongoing use of the spent fuel pool cooling system could introduce hazards to some wildlife and could create water-use conflicts with wildlife in the area. Wildlife species that occupy onsite habitats are exposed to a variety of contaminants and factors associated with nuclear power plant and at-reactor ISFSI operations and maintenance. The maintenance required for landscaped areas generally keeps the diversity of wildlife at a reduced level compared to unmaintained surrounding habitats. Wildlife species within the security areas are typically limited by the low quality of the habitat present and generally include common species adapted to industrial developments (NRC 2013a).

3.9 Aquatic Ecology

This section describes the general aquatic resources that could be affected by the continued storage of spent fuel in spent fuel pools and at-reactor ISFSIs. Aquatic biota may be subject to potential effects associated with spent fuel storage facilities (wet storage in spent fuel pools or dry storage in casks).

The information contained in the following sections is a brief summary of aquatic resources known to exist near nuclear power plant sites, which include spent fuel pools and ISFSIs. The majority of this information comes from the License Renewal GEIS (NRC 2013a), which describes a range of potentially affected aquatic resources that may be found in the vicinity of nuclear power plants. The affected environment for at-reactor continued storage would be similar to the affected environment described in the License Renewal GEIS because spent fuel pools and at-reactor ISFSIs are located within power reactor sites, and the end of reactor operations would not significantly alter the affected environment for aquatic resources at most sites. However, when operation of a reactor cooling system ceases, the aquatic environment would be altered to some degree because less water would be withdrawn and discharged. Therefore, less impingement and entrainment would occur and the thermal plume associated with the discharge would be smaller. Once operation of the spent fuel pool ceases, no water would be withdrawn or discharged as a part of continued storage activities. A more detailed account of the range of aquatic environments existing at these facilities can be found in the License Renewal GEIS.

Nuclear power plant sites must be located near waterbodies that are large enough to adequately meet the demands of a plant's cooling systems. At-reactor ISFSIs are generally located near nuclear power plants, and nuclear power plant sites are usually located near marine and estuarine coastal areas, on the Great Lakes, or along major rivers or reservoirs. Several power plants are sited near small streams (e.g., the V.C. Summer plant in South Carolina and the Clinton plant in Illinois), and initial construction activities included impounding the streams to create cooling ponds or reservoirs.

To establish the affected environment for this analysis, aquatic resources are described in terms of aquatic habitats (freshwater rivers, reservoirs, lakes, and coastal estuarine and marine systems) and aquatic biota (fish, macroinvertebrates, zooplankton, phytoplankton and macrophytes, other aquatic vertebrates and invertebrates, and aquatic vegetation).

3.9.1 Aquatic Habitats

A wide range of aquatic habitats occur in the vicinity of U.S. nuclear power plant sites due to differences in geographies, physical conditions (e.g., substrate type, temperature, turbidity, and light penetration), chemical conditions (e.g., dissolved oxygen levels and nutrient concentrations), biological interactions (e.g., consumption of various algal and invertebrate species that provide habitats, such as seagrass or shellfish beds), seasonal influences (including climate change), and man-made modifications. The interactions of these factors often define the specific type of aquatic habitats and communities within a particular area. Three main aquatic ecosystem types occur near nuclear power plant sites: freshwater, estuarine, and marine ecosystems.

3.9.1.1 Freshwater Systems

Freshwater systems are generally classified into two groups based on the degree of water movement. Lentic systems are waterbodies with standing or slow-flowing water, such as ponds, lakes, reservoirs, and some canals. During warmer months, the upper and lower depths will stratify or become two layers that have different temperatures, oxygen content, and nutrient content. Lotic habitats, on the other hand, feature moving water and include natural rivers and streams and some artificial waterways. Most lotic habitats do not stratify (Morrow and Fischenich 2000). Some freshwater aquatic species may occur in both lentic and lotic habitats. However, many species are adapted to the physical, chemical, and ecological characteristics of one system or the other and the overall ecological communities present within these aquatic ecosystem types differ for different regions of the country (NRC 2013a).

A number of major rivers provide cooling water for nuclear power plant sites. The geographic area, gradient of the river bed, substrate, temperature, dissolved oxygen concentration, depth, light penetration, velocity of the current, and source of nutrients and organic matter at the base of the food chain will largely determine species composition and ecological conditions within

Affected Environment

riverine environments. In some instances, nuclear power plants that use rivers for cooling are located on sections of rivers that have been impounded, creating reservoirs. Impoundment of a river can alter ecological communities occurring in a given waterbody by blocking movement of aquatic organisms, changing flow and temperature characteristics, adding chemical pollutants, and introducing non-native species. Fish species in numerous reservoirs are often stocked and managed to support local recreational fisheries (NRC 2013a).

Littoral, pelagic, and profundal habitat zones are all found within lentic systems and are classified on the basis of water depth and light penetration in the water. Littoral habitats refer to nearshore shallower waters where sufficient light reaches the bottom to enable rooted plants to grow. Pelagic habitats include open offshore waters where light intensity is great enough for photosynthesis to occur. Profundal habitats are found in deep-water areas where light penetration is insufficient to support photosynthesis (Armantrout 1998). Unique ecological communities inhabit each zone, reflecting the preferences and tolerances of various aquatic species (NRC 2013a).

In the Great Lakes, species diversity and biomass of fish are greater nearshore than in the offshore areas since these areas feature habitats and conditions that are favorable for most species of Great Lakes fish for at least some portion of their life cycle (Edsall and Charlton 1997). Threats to the ecological integrity of the Great Lakes include eutrophication (nutrient enrichment), land-use changes, overfishing, invasive species, and pollution (Beeton 2002). Regulations and best management practices have been implemented to reduce nutrient inputs and control land-use changes, such as shoreline alteration and destruction of wetlands. Invasive species, however, have become a major problem as nonindigenous species gain access to the Great Lakes. The introduction of invasive species can result in changes to native ecological communities (NRC 2013a).

3.9.1.2 Estuarine Ecosystems

Brackish to saltwater estuarine ecosystems occur along the coastlines of the United States. General habitat types found within estuarine ecosystems include the mouths of rivers, tidal streams, shorelines, salt marshes, mangroves, seagrass communities, soft-sediment habitats

Aquatic Ecosystem Types

- **Freshwater:** Waters that contain a salt concentration or salinity of less than 0.5 parts per thousand (ppt) or 0.05 percent.
 - *Lentic:* Stagnant or slow-flowing fresh water (e.g., lakes and ponds).
 - *Lotic:* Flowing fresh water with a measurable velocity (e.g., rivers and streams).
- **Estuarine:** Coastal bodies of water, where freshwater merges with marine waters. The waterbodies are often semi-enclosed and have a free connection with marine ecosystems (e.g., bays, inlets, lagoons, and ocean-flooded river valleys). Salinity concentrations fluctuate between 0 and 30 ppt, varying spatially and temporally due to location and tidal activity.
- **Marine:** Waters that contain a salt concentration of about 30 ppt (e.g., ocean overlying the continental shelf and associated shores).

(e.g., mudflats and shellfish beds), and open water. Estuaries can serve as important staging points during the migration of certain fish species, providing a refuge from predation while physiologically adjusting to the changes in salinity. Numerous marine fish and invertebrate species spawn in or use estuaries as places for larvae and juveniles to develop before moving to marine habitats. Estuarine habitats also support important commercial or recreational finfish and shellfish species (NRC 2013a).

3.9.1.3 Marine Ecosystems

Marine ecosystems occur along the coastline and offshore of the United States. General habitat types within marine ecosystems include the rocky intertidal, rocky subtidal, deep-sea communities, algal communities (e.g., kelp beds), soft-sediment communities (e.g., sandy bottom or mudflats), and the open water or pelagic habitats. Species often compete for space within rocky subtidal and intertidal habitats. The area where species eventually settle is often a tradeoff between accommodating physiological stress and avoiding predation and/or competition with other species. For example, lower depths may provide a more ideal habitat in terms of physical requirements (e.g., temperature, pressure, salinity, and avoiding desiccation), but shallower areas may provide a refuge from predation. As a result, many organisms (including algae, invertebrates, and some fish) that use rocky subtidal and intertidal habitats are restricted to a depth zone that balances physiological and biological pressures (Witman 1987). Marine habitats support important commercial or recreational finfish and shellfish species (NRC 2013a).

3.9.2 Aquatic Organisms

Aquatic organisms are known to occur near nuclear power plant sites. The following discussions provide high-level overviews of aquatic organisms that are known to exist in habitats near nuclear power plant sites. Additional details regarding aquatic organisms and species that occur near nuclear power plant sites are provided in the License Renewal GEIS (NRC 2013a).

3.9.2.1 Fish

Fish can be characterized as freshwater, estuarine, marine, and migratory (e.g., anadromous and catadromous) species. The first three categories are based on salinity regimes. For example, freshwater fish usually inhabit waters with a salinity of less than 0.5 parts per thousand (ppt), although some species can tolerate a salinity as high as 10 ppt; estuarine fish inhabit tidal waters with salinities that range between 0 and 30 ppt; and marine fish typically live and reproduce in coastal and oceanic waters with salinities that are at or more than 30 ppt.

Affected Environment

Migratory fish are generally categorized by their migratory patterns, or periodic movements that result in regularly alternating between two or more habitats (Northcote 1978). For example, anadromous species migrate from the ocean waters to freshwater to spawn, while the opposite situation occurs for catadromous species. Amphidromous species also migrate between fresh and saltwater, but these migrations are not related to the reproductive cycle. Potamodromous species migrate entirely within a freshwater system (e.g., some species tend to move to upstream areas for spawning) whereas oceanodromous species migrate entirely within the ocean (e.g., some species tend to move northward as waters warm and southward as they cool). A number of fish species that occur in the vicinity of the power plants are considered commercially or recreationally important, while others serve as forage for those species (NRC 2013a).

Fish are also categorized by where in the waterbody they inhabit. For example, pelagic fish live within the waters that extend from right below the surface to right about the sea floor (or bottom of the waterbody). Demersal fish live on or near the bottom of the sea floor (or bottom of the waterbody) and benthic fish live on the sea floor (or bottom of the waterbody). The distribution of demersal and benthic fish is usually highly dependent on the type of substrate that lines the floor of the waterbody. For example, certain fish prefer soft, sandy bottom habitat, whereas other fish prefer rocky substrates with crevices in which to hide. Other typical bottom water substrates that provide fish habitat include mud flats, kelp beds, submerged aquatic vegetation, salt marshes, mangroves, shellfish beds, and coral reefs.

3.9.2.2 Aquatic Macroinvertebrates

A broad range of aquatic macroinvertebrates may be found near nuclear power plant sites. Macroinvertebrates are responsible for controlling key ecosystem processes, including primary production, decomposition, nutrient regeneration, water chemistry, and water clarity. Mussels consume plankton (i.e., planktivores) and are prey for other organisms. Some macroinvertebrates require good water quality and physical habitat conditions that will support populations of their host fish species. Williams et al. (1993) reported that, of the nearly 300 native freshwater mussels in the United States and Canada, nearly 72 percent are considered endangered, threatened, or of special concern, almost 5 percent are of undetermined status, and less than 24 percent are considered stable. Freshwater mussels occur in the vicinity of most plants that use freshwater as a cooling-water source. Several species of non-native freshwater and saltwater mussels and clams have been introduced to the United States and have reached nuisance levels. These species can alter trophic and nutrient dynamics of aquatic ecosystems and displace native mussels. Many of the nuclear plants have programs in place to monitor for these nuisance species and, as appropriate, to control them, usually using biocides (NRC 2013a).

3.9.2.3 Zooplankton

Zooplankton are small animals that float, drift, or weakly swim in the water column of any waterbody, and include, among other forms, fish eggs and larvae with limited swimming ability, larvae of benthic invertebrates, medusoid forms of hydrozoans, copepods, shrimp, and krill (Euphausiids). Plankton are often categorized by how and where they inhabit the water column, including holoplankton (plankton that spend their entire lifecycle within the water column), meroplankton (plankton that spend a portion of their lifecycle in the water column), and demersal (benthic species that primarily reside on the seafloor but migrate into the water column on a regular basis). Zooplankton play an important role as a trophic link between phytoplankton and fish or other secondary consumers (NRC 2013a).

3.9.2.4 Single-Celled Algae

Phytoplankton, also referred to as microalgae, contain chlorophyll and require sunlight to live and grow. Most phytoplankton are buoyant and float in the upper part of the waterbodies, where sunlight penetrates the water. Phytoplankton are an important food source for some invertebrate and fish species and are important for carbon fixation (converting carbon dioxide to organic materials via photosynthesis). Periphyton (algae attached to solid submerged objects) includes species of diatoms and other algae that grow on natural or artificial substrates.

3.9.2.5 Other Aquatic Invertebrates and Vertebrates

Other important aquatic species include cephalopods (e.g., squid and octopus), freshwater mammals, marine mammals (e.g., seals and whales), sea turtles and other reptiles. Many of these species are protected under various Federal statutes and regulations, such as the Endangered Species Act and the Marine Mammal Protection Act, as further described in Section 3.10.

3.9.2.6 Aquatic Macrophytes

Submerged aquatic vegetation, such as seagrass, provides important habitat for aquatic organisms and is often referred to as underwater meadows or forests. Submerged aquatic vegetation provides food, structurally complex habitat, areas to hide from predators, and breeding and nursery grounds for many aquatic species.

Macroalgae, such as kelp and *Sargassum*, form communities and provide habitat, refugia, and food for other species such as fish and sea turtle hatchlings. Phytoplankton and macroalgae are also important for carbon fixation (converting carbon dioxide to organic materials via photosynthesis).

3.10 Special Status Species and Habitats

Several Federal and State statutes and regulations protect aquatic and terrestrial species and habitats. Federally listed species, critical habitat, essential fish habitat (EFH), and other special status species and habitats are known to occur near nuclear power plant sites (NRC 2013a). The License Renewal GEIS provides additional details on the types of special status species that have occurred near nuclear power plants, such as sea turtles, fish, birds, and other protected species.

Federally listed threatened and endangered species and critical habitat are protected under the Endangered Species Act of 1973 (ESA), while State-listed species and habitats are protected under provisions of various State statutes and regulations. Under Section 7 of the ESA, the NRC must consult with the U.S. Fish and Wildlife Service (FWS) or the National Marine Fisheries Service (NMFS) for actions that could affect Federally listed species or critical habitat. Prior to initial licensing, the NRC would be required to consult with the FWS or the NMFS under Section 7 of the ESA to determine the presence of and potential impacts to any Federally listed species or critical habitat at or near the site. Section 7 ESA consultation could also be required after a license is granted if operations could affect a Federally listed species or designated critical habitat and if the criteria in 50 CFR Part 402 are met for initiation or reinitiation of Section 7 consultation, as described in more detail in Section 4.11. The objective of the consultation is to identify and assess potential impacts to listed species and critical habitat. Any ongoing or proposed activity associated with the operation or maintenance of spent fuel pools or ISFSIs that has the potential to affect a Federally listed species, and meets the criteria in 50 CFR Part 402 for initiation or reinitiation of Section 7 consultation, requires that the NRC initiate or reinstate ESA Section 7 consultation with the FWS or the NMFS depending on the species. Additional information on how the consultation process is used to identify, evaluate, and mitigate potential impacts to Federally listed species and designated critical habitat is discussed in Chapter 4.

Terms Related to Threatened, Endangered, and Protected Species and Habitats

- ***Endangered Species:*** Animal or plant species in danger of extinction throughout all or a significant portion of its range.
- ***Threatened Species:*** Animal or plant species likely to become endangered within the foreseeable future throughout all or a significant portion of its range.
- ***Candidate Species:*** Animal or plant species for which the FWS or NMFS has on file sufficient information on vulnerability and threats to support a proposal to list it as endangered or threatened.
- ***Proposed Species:*** Animal or plant species that is proposed in the *Federal Register* to be listed under Section 4 of the Endangered Species Act.
- ***Designated Critical Habitat:*** Specific geographic areas, whether occupied by a listed species or not, that are essential for its conservation and that have been formally designated by rule published in the *Federal Register*.
- ***Essential Fish Habitat:*** Those waters and substrates needed by Federally managed marine and anadromous fish for spawning, breeding, feeding, or growth to maturity.

The Magnuson-Stevens Fishery Conservation and Management Act, as amended, calls for the description, identification, and management of EFH to help conserve and manage Federally managed fish and shellfish resources. EFH is defined as “those waters and substrate necessary to fish for spawning, breeding, feeding, or growth to maturity.” The NRC must consult with NMFS for any Federal action that may adversely affect EFH. Spent fuel pools that withdraw and discharge water to marine, estuarine, and coastal waters near designated EFH have the potential to affect EFH because they have a potential to alter, damage, or destroy EFH components, thereby affecting the fishery resources that use them (NRC 2013a).

Marine mammals are protected under the Marine Mammal Protection Act of 1972, as amended (MMPA), which also assigns responsibility for managing cetaceans (i.e., porpoises and whales) and most pinnipeds (i.e., seals, fur seals, and sea lions) to the NMFS. The FWS is responsible for managing walrus, polar bears, fissionpeds (i.e., otters), and sirenians (i.e., dugongs and manatees). The Act prohibits, with certain exceptions, the “take” (i.e., harming) of marine mammals in U.S. waters. The MMPA has no Federal consultation requirement; therefore, applicants and licensees are directly responsible for compliance with the MMPA. Both the Magnuson–Stevens Act and MMPA are administered by the NMFS.

The Bald and Golden Eagle Protection Act of 1940, as amended, provides for the protection of the bald eagle (*Haliaeetus leucocephalus*) and the golden eagle (*Aquila chrysaetos*) by prohibiting the taking, possession, and commerce of these birds, their nests, or their eggs. The Act prescribes criminal and civil penalties for persons violating the conventions identified in 16 USC 668. In addition, the Migratory Bird Treaty Act of 1918, as amended, protects migratory birds included in the terms of the conventions identified in 16 USC 703. Both acts are administered by the FWS. Similar to the MMPA, these two acts lack Federal consultation requirements; therefore, applicants and licensees are directly responsible for compliance.

The Fish and Wildlife Coordination Act requires the NRC to consult with the FWS and the fish and wildlife agencies of States if a Federal permit or license could impound, divert, or otherwise modify waterbodies. The purpose of the consultation is to prevent loss of and damage to wildlife resources.

The Coastal Zone Management Act of 1972 requires applicants for any NRC license or permit to conduct an activity, in or outside of the coastal zone, that would affect any land or water use or natural resource of the coastal zone to provide to the NRC a certification that the proposed activity complies with any applicable State Coastal Zone Management Plan. An applicant must also provide this certification to the State, and the State must notify the NRC whether the State concurs with the applicant’s certification. The NRC cannot issue a license or permit to an applicant until the State has concurred with the applicant’s certification.

3.11 Historic and Cultural Resources

This section describes the historic and cultural resources that could be affected by continued storage. For the purposes of this GEIS, the area of potential effect is the area that may be impacted by land-disturbing activities or other operational activities associated with continued storage of spent fuel (whether in spent fuel pools or at an at-reactor ISFSI), including the viewshed. This determination is made irrespective of land ownership or control. A description of these sites, including spent fuel pools and at-reactor ISFSIs, is provided in Section 2.1 of this GEIS.

Historic and cultural resources are the remains of past human activity and include prehistoric era and historic era archaeological sites, historic districts, buildings, or objects with an associated historical, cultural, archaeological, architectural, community, or aesthetic value. Historic and cultural resources also include traditional cultural properties that are important to a living community of people for maintaining their culture. "Historic property" is the legal term for a historic or cultural resource that is eligible for listing on the National Register of Historic Places (NRHP) (NRC 2013a).

Historic Property (36 CFR 800.16(l)(1))

Any prehistoric or historic district, site, building, structure, or object included in, or eligible for inclusion in, the *National Register of Historic Places* maintained by the Secretary of the Interior. Historic properties also include artifacts, records, and remains that are related to and located within such properties. The term includes properties of traditional religious and cultural importance to an Indian Tribe or Native Hawaiian organization and that meet the *National Register* criteria.

The National Historic Preservation Act of 1966 (NHPA) requires Federal agencies to take into account the effects of their undertakings on historic properties. Historic properties are defined as resources that are eligible for listing on the NRHP. The criteria for NRHP eligibility are listed in 36 CFR 60.4 and include, among other things, (1) association with significant events that have made a significant contribution to the broad patterns of history, (2) association with the lives of persons significant in the past, (3) embodiment of distinctive characteristics of type, period, or method of construction, and (4) sites or places that have yielded or may be likely to yield important information in history or prehistory (ACHP 2008). The historic preservation review process (Section 106 of the NHPA) is outlined in regulations issued by the Advisory Council on Historic Preservation in 36 CFR Part 800.

The prehistoric era refers to the period before Europeans arrived in North America in the 1490s. Some of the most heavily used areas during this period were along rivers, lakes, and the seashore. These locations provided freshwater and the most abundant food sources, as well as the most efficient ways to travel. As a result, prehistoric era archaeological sites tend to be found along these waterways. Prehistoric archaeological resources include small temporary camps, larger seasonal camps that were revisited year after year, large village sites that were

occupied continuously over several years or potentially for centuries, or specialized-use areas associated with fishing or hunting or with tool and pottery manufacture (NRC 2013a).

The historic era refers to the period after Europeans arrived in North America. Similar to prehistoric populations, historic era sites tend to be clustered near waterways because water provided a means for transportation and trade, and supported agriculture. Historic era resources include farmsteads, mills, forts, residences, industrial sites (such as mines or canals), and shipwrecks (NRC 2013a).

Traditional cultural properties are historic and cultural resources that are associated with cultural practices or beliefs of a living community, and are often associated with Native American cultures. Traditional cultural properties can be considered historic properties and be included on the NRHP. Examples include traditional gathering areas where particular plants or materials were harvested, locations where a community has traditionally carried out economic, artistic, or other cultural practices important to maintaining its identity, or burial locations that connect individuals or groups with their ancestors. The locations of traditional cultural properties are often kept private; State Historic Preservation Offices can often be unaware of these locations (NRC 2013a).

Historic and cultural resources, especially archaeological sites, are sensitive to disturbance and are nonrenewable. Even a small amount of ground disturbance (e.g., ground clearing and grading) could affect a small but significant resource. Much of the information contained in an archaeological site is derived from the spatial relationships between soil layers and associated artifacts. Once these spatial relationships are altered, they can never be reclaimed. (NRC 2013a)

Nuclear power plant sites are located in areas of focused past human activities (along waterways) and, as such, there is a potential for historic and cultural resources to be present near most nuclear power plants. For example, as part of the recent License Renewal GEIS update, the NRC reviewed historic and cultural resource reviews that were performed for 40 license renewals. For sites that had conducted field investigations, on average, the number of historic and cultural resources present were 35 per site (NRC 2013a). Sites identified included a variety of resources, including village and town sites, and cemeteries (NRC 2013a).

Most existing nuclear power plants in the United States were constructed in the 1960s, 1970s, and early 1980s. Although the NHPA was passed in 1966, the process for complying with the law was developing during the 1970s and early 1980s (NRC 2013a). Many existing nuclear power plant sites were not investigated for the presence of historic and cultural resources prior to initial facility construction. Based on experience from reactor license renewal, early site permit, and combined license environmental reviews, extensive ground-disturbing activities occurred during initial nuclear power plant construction. These construction activities extensively disturbed much of the land in and immediately surrounding the power block.

Affected Environment

The term “power block” refers to the buildings and components directly involved in generating electricity at a power plant. At a nuclear power plant, the components of the power block vary with the reactor design, but always include the reactor and turbine building, and usually include several other buildings that house access, reactor auxiliary, safeguards, waste processing, or other nuclear generation support functions. Buildings within the power block require significant excavation of existing material, followed by placement of structural fill for a safe and stable base. Building excavations are extensive, and the area of excavation is larger than the as-built power block, and reactor containment.

It is unlikely that historic and cultural resources are present within heavily disturbed areas of a power plant site. However, less-developed or disturbed portions of a power plant site, including areas that were not extensively disturbed (e.g., construction laydown areas), could still contain unknown historic and cultural resources. Laydown areas are lands that were cleared, graded, and used to support fabrication and installation activities during initial power plant construction. Many ISFSIs have been constructed in less-developed and disturbed areas outside the power block. Based on experience from reactor license renewal, early site permit, and combined license environmental reviews, historic and cultural resource sites tend to occur in less-developed and undeveloped areas of the power plant site. Accordingly, many licensees have developed and implemented historic and cultural resource management plans and procedures that consider and protect known resources and address inadvertent discoveries.

For continued storage, the NRC will consider impacts to historic and cultural resources in this GEIS through its NEPA requirements in 10 CFR Part 51. Neither the rulemaking nor this GEIS identifies specific sites for NRC licensing actions that would trigger Section 106 consultation requirements that are normally conducted during site-specific licensing reviews. This rulemaking is not a licensing action; it does not authorize the initial or continued operation of any nuclear power plant, and it does not authorize storage of spent fuel. This GEIS describes the potential impacts to historic and cultural resources associated with continued storage of spent fuel at both at-reactor and away-from-reactor ISFSIs.

For site-specific licensing actions (i.e., new reactor licensing, reactor license renewal, and site-specific at-reactor and away-from-reactor ISFSIs), applicants are required to provide historic and cultural resource information in environmental reports submitted with license applications. To prepare these assessments, applicants conduct cultural resource surveys and may develop management plans or procedures, if such procedures are not already in place. This information assists the NRC in its review of the potential impacts to historic and cultural resources. As part of these site-specific licensing actions, the NRC has and will continue to comply with the consultation requirements in the NHPA regulations in 36 CFR Part 800 and consult with State Historic Preservation Offices or appropriate Tribal Historic Preservation Officer, Tribal representatives, and other interested parties to determine the area of potential effect and if the proposed licensing action would affect historic properties. As identified in 36 CFR 800.2,

interested parties can include representatives of the local government, the license applicant, the Advisory Council on Historic Preservation, the public, and organizations with a demonstrated interest in the undertaking (proposed licensing action). The NRC will consider information provided by these consulting parties when making determinations under the NHPA. If historic and cultural resources are present within the area of potential effect, identification of historic properties, adverse effects, and potential resolution of adverse effects will be done through consultation and application of the NRHP criteria in 36 CFR 60.4.

3.12 Noise

This section describes noise associated with continued storage. The affected environment is the environment that exists at and around spent fuel pools and at-reactor ISFSIs where continued storage activities would occur. Noise describes unwanted sound that is undesirable because it interferes with speech, communication, or hearing; is intense enough to damage hearing; or is otherwise annoying (NRC 2002). A common sound measurement used to indicate sound intensity is the A-weighted sound level (designated as decibel-A or dB(A)). The decibel expresses sound levels on a logarithmic scale and accounts for the response of the human ear. The noise levels experienced at spent fuel storage locations at a particular point in time depends on what noise generating activities are occurring in the vicinity.

Ambient noise levels depend in part on the amount of development that has occurred in the area around nuclear power plant sites. In rural or low-population areas, background noise levels are typically in a range of 35 to 45 dB(A) (NRC 2013a). In areas where more development has occurred, the surrounding community and highway noise results in baseline noise levels around 60 to 65 dB(A) (NRC 2013a). Over time, the ambient noise levels at a particular location can change as the area experiences changes in development. For example, if new development activities that generate additional noise are initiated, then the ambient noise levels in the area would increase.

Noise can be examined from the perspective of two different receptor groups: workers and the general public. There are no Federal regulations for public exposure to noise. Impacts are primarily evaluated in terms of adverse reactions of the public to noise. The EPA has developed guideline sound levels below which the general public should be protected from activity interference and annoyance. For residential areas, the EPA identified thresholds over a 24-hour period of 45 dB(A) for indoor exposures and 55 dB(A) for outdoor exposures (EPA 1974). At the Federal level, the Occupational Safety and Health Administration regulates noise exposure for workers. The permissible noise exposure limit varies by duration. The limit ranges from 90 dB(A) for a duration of 8 hours per day to 115 dB(A) for 15 minutes or less (29 CFR 1910.95).

Baseline noise characteristics would also include noise generated by spent fuel storage activities. Noise has been assessed in various site-specific, at-reactor ISFSI environmental

Affected Environment

reviews, such as the Calvert Cliffs ISFSI license renewal (NRC 2012a) for dry cask storage and the GEH Morris ISFSI license renewal (NRC 2004) for pool storage. Activities that involve construction equipment, such as decommissioning, generate the most ongoing noise, with earthwork and excavation equipment noise levels exceeding 90 dB(A) (NRC 2002). Noise associated with continued storage is primarily limited to mobile sources associated with the movement of spent fuel between the spent fuel pool and the dry cask storage pad (see NRC 2012a).

Proximity is a factor when assessing impacts because noise levels decrease as distance from the source increases. Spent fuel storage facilities typically have large buffer areas between the facility and the nearest receptor. In addition, other barriers such as buildings, vegetation, and topography can also reduce noise levels.

3.13 Aesthetics

Aesthetic resources refer to the visual appeal of a tract of land. The scenic quality of an area may include natural and man-made landscapes and the ways in which the two are integrated. Aesthetic resources can include scenic viewsheds with waterbodies, topographic features, or other visual landscape characteristics. The baseline for evaluation of impacts to aesthetic resources is the existing visual condition of a site. Assessment of potential impacts to aesthetic resources requires evaluation of the degree to which a project would contrast adversely with the existing landscape. Section 2.1 provides a generic description of nuclear power plant sites and storage facilities.

3.14 Waste Management

This subsection describes the various types of wastes generated and managed as a result of the continued storage of spent fuel.

3.14.1 Low-Level Radioactive Waste

Low-level waste (LLW) is radioactive waste that (1) is not classified as high-level radioactive waste, transuranic waste, spent fuel, or byproduct material defined in paragraphs (2), (3), and (4) of the definition of byproduct material set forth in 10 CFR 20.1003.

Almost all LLW generated from reactor operation activities, including management of spent fuel stored in pools and ISFSIs, is shipped offsite, either directly to a disposal facility or to a processing center before being sent to a disposal site. The number of shipments leaving each reactor site varies but generally ranges from a few to about 100 per year. Subpart K of 10 CFR Part 20 discusses the various means by which the licensees may dispose of their radioactive waste. The transportation and land disposal of solid radioactive wastes are performed in accordance with the applicable requirements of 10 CFR Part 71 and 10 CFR Part 61, respectively.

There are currently four operating disposal facilities in the United States that are licensed to accept commercial-origin LLW. They are located in Barnwell, South Carolina; Richland, Washington; Clive, Utah; and Andrews County, Texas. The facility in Utah, operated by EnergySolutions, is licensed to accept only Class A LLW, whereas the other three facilities can accept Class A, B, and C wastes (GAO 2004). In 2001, the South Carolina legislature imposed restrictions on the Barnwell facility such that after June 2008, the facility can accept waste from generators in only three States: South Carolina, New Jersey, and Connecticut. The Barnwell facility is projected to close in 2038 (EnergySolutions 2012). The Richland facility accepts LLW from 11 States: Washington, Alaska, Hawaii, Idaho, Montana, Oregon, Utah, Wyoming, Colorado, Nevada, and New Mexico. It is expected to close in 2056. The EnergySolutions facility in Utah accepts only Class A waste, but the waste can come from any state. This facility currently does not have a projected closing date. The Waste Control Specialists, LLC, site in Texas accepts Class A, B, and C wastes from Texas and Vermont per the Texas Low-Level Radioactive Waste Disposal Compact. In addition, individual waste generators from any other state may apply for an agreement to dispose of their non-Compact generated waste at the Waste Control Specialists, LLC site. For example, waste generators from more than 13 non-Compact States have agreements in place to dispose of waste at this site (TCC 2014). Currently, there is no projected closing date for the Waste Control Specialists, LLC LLW site.

Waste Types Associated with Spent Fuel Storage

Low-level Radioactive Waste (LLW) – radioactive waste not classified as high-level waste, transuranic waste, spent nuclear fuel, or byproduct material. LLW for near surface disposal is classified into Class A, Class B, or Class C waste, and must be disposed of in facilities licensed by the NRC or an NRC Agreement State. Greater-than-class-C (GTCC) waste is not created as a result of continued storage activities and is not within the scope of this GEIS.

Mixed Waste: Waste that is both hazardous and radioactive.

Hazardous Waste: A solid waste or combination of solid wastes that, because of its quantity, concentration, or physical, chemical, or infectious characteristics, may (1) cause or significantly contribute to an increase in mortality or an increase in serious irreversible or incapacitating reversible illness or (2) pose a substantial present or potential hazard to human health or the environment when improperly treated, stored, transported, disposed of, or otherwise managed (as defined in the Resource Conservation and Recovery Act, as amended, 1976).

Nonradioactive Nonhazardous Waste: Waste that is neither radioactive nor hazardous.

Operating nuclear power plants, including activities associated with spent fuel storage, generate LLW generally consisting of air filters, cleaning rags, protective tape, paper and plastic coverings, discarded contaminated clothing, tools, equipment parts, and solid laboratory wastes (all these are collectively known as dry active waste) and wet wastes that result during the processing and recycling of contaminated liquids at the plants. Wet wastes generally consist of spent demineralizer or ion exchange resins, and spent filter material from the equipment drain,

Affected Environment

floor drain, and water cleanup systems. The wet wastes are generally solidified, dried, or dewatered to make them acceptable at a disposal site (NRC 2013a).

The quantity of LLW generated by reactor operation, including spent fuel storage in spent fuel pools, varies annually depending on the number of maintenance activities (NRC 2013a). A pressurized water reactor, on average, generates approximately 300 m³ (10,600 ft³) and 1,000 Ci (3.7×10^{13} Bq) of LLW per year (Table 6.6 in NRC 2013a). The annual volume and activity of LLW generated at a boiling water reactor are approximately twice the values indicated for a pressurized water reactor. Approximately 95 percent of this waste is Class A (NEI 2013). After reactor operations have ceased, the number and types of activities generating LLW will decrease. Therefore, the annual quantity of LLW generated from storage of spent fuel during continued storage is expected to be a small fraction of that generated while the nuclear power plant is operating because there are less waste generating activities occurring.

3.14.2 Mixed Waste

Wastes that are both radioactive and hazardous are called mixed waste. These wastes are regulated by the EPA or an authorized State for the hazardous component, and by the NRC or an agreement State for the radioactive component. The types of mixed wastes generated in the storage of spent fuel include organics (e.g., waste oils and halogenated organics), metals (e.g., lead, mercury, chromium, and cadmium), solvents, paints, and cutting fluids.

The quantity of mixed waste generated by an operating nuclear power plant is generally relatively small (NRC 2013a). For example, the environmental impact statement (EIS) for the Fermi Unit 3 combined license application stated that less than 0.5 m³/yr (0.65 yd³/yr) of mixed waste would be generated during operation (NRC 2013e).

Because of the added complexity of dual regulation, the management and disposal of mixed waste is more problematic than for the other types of wastes. Similar to hazardous waste, mixed waste is generally accumulated onsite in designated areas as authorized under the Resource Conservation and Recovery Act (RCRA), and then shipped offsite for treatment as appropriate and for disposal. The disposal facilities that are authorized to receive mixed waste for disposal are the EnergySolutions facility in Utah and the Waste Control Specialists, LLC, site in Texas.

3.14.3 Hazardous Waste

Hazardous waste is defined by the EPA in 40 CFR Part 261, "Identification and Listing of Hazardous Waste," as solid waste that (1) is listed by the EPA as being hazardous; (2) exhibits one of the characteristics of ignitability, corrosivity, reactivity, or toxicity; or (3) is not excluded by the EPA from regulation as being hazardous. All aspects of hazardous waste generation, treatment, transportation, and disposal are strictly regulated by the EPA or by the States under

agreement with the EPA per the regulations promulgated under RCRA. Hazardous waste does not contain radioactive waste (and if mixed with radioactive waste would be categorized as “mixed waste,” as explained above in Section 3.14.2).

The types of hazardous waste typically generated by nuclear power plants during storage operations include waste paints, laboratory packs, and solvents. The quantities of these wastes generated by an operating nuclear power plant can vary between facilities, but the quantities generally are relatively small when compared with the quantities at most other industrial facilities that generate hazardous waste (NRC 2013a). Nuclear power plants would likely accumulate their hazardous waste onsite as authorized under RCRA and transport it to a treatment facility. Residues remaining after treatment are sent to a permanent disposal facility. There are many RCRA-permitted treatment and disposal facilities available throughout the United States.

3.14.4 Nonradioactive, Nonhazardous Waste

Similar to other industrial activity, the continued storage of spent fuel will generate wastes that are not contaminated with either radionuclides or hazardous chemicals. These wastes include trash, paper, wood, construction and demolition materials, and sanitary wastes (sewage). Nonhazardous solid wastes as defined in 40 CFR Part 261 are collected and disposed of in a local landfill. Sanitary wastes may be treated onsite and the residues sent to local landfills or discharged directly to a municipal sewage treatment facility. Sanitary waste may also be collected in onsite septic tanks, which are emptied periodically, and then the waste is shipped to a local sanitary waste treatment plant. The wastes and sewage are tested for radionuclides before being sent offsite to ensure that no inadvertent contamination occurs. Offsite releases from onsite sewage treatment plants are conducted under NPDES permits. As with operating nuclear power plants, stormwater runoff may be collected and tested before it is discharged offsite (NRC 2013a).

3.14.5 Pollution Prevention and Waste Minimization

Waste minimization and pollution prevention are important elements of operations at all nuclear power plants and at-reactor ISFSIs. Licensees are required to consider pollution prevention measures as dictated by the Pollution Prevention Act of 1990 and RCRA.

In addition, as noted in the License Renewal GEIS and in recent EISs for new reactors and license renewal applications, licensees are likely to have waste-minimization programs in place that are aimed at minimizing the quantities of waste sent offsite for treatment or disposal. Waste-minimization techniques employed by the licensees may include source reduction and recycling of materials either onsite or offsite. The establishment of a waste-minimization program is also a requirement for managing hazardous wastes under RCRA.

3.15 Transportation

The affected environment for transportation associated with continued storage includes the characteristics of the reactor site that support transportation activities, workers involved in transportation activities, and the local, regional, and national transportation networks and populations that use or live along these networks.

All nuclear power plants sites are serviced by controlled access roads. In addition to the access roads, many of the plants also have railroad connections for moving heavy equipment and other materials. Some of the plants that are located on navigable waters, such as rivers, the Great Lakes, or oceans, have facilities to receive and ship loads on barges (NRC 2013a). Power plant sites provide a network of roads and sidewalks for vehicles and pedestrians as well as parking areas for workers and visitors (NRC 2013a).

Local and regional transportation networks in the vicinity of nuclear power plant sites may vary considerably depending on the regional population density, location and size of local communities, nature of economic development patterns, location of the region relative to interregional transportation corridors, and land surface features, such as mountains, rivers, and lakes. The impacts of employee commuting patterns on the transportation network in the vicinity of nuclear power plants depend on the extent to which these factors limit or facilitate traffic movements and on the size of the plant workforce that uses the network at any given time. Impacts at the local level in the immediate vicinity of power plant sites vary depending on the capacity of the local road network, local traffic patterns, and particularly the availability of alternate routes for power plant workers. Given the rural locations of most power plant sites, site traffic has a small impact on the local road system, since often there is not much other traffic on local roads in the immediate vicinity of the plant. Because most sites have only one access road, there may be congestion on this road at certain times, such as during shift changes (NRC 2013a).

For transportation of radioactive material from a nuclear power plant site, the affected environment includes all rural, suburban, and urban populations living along the transportation routes within range of exposure to radiation emitted from the packaged material during normal transportation activities or that could be exposed in the unlikely event of a severe accident involving a release of radioactive material. The affected environment also includes people in vehicles on the same transportation route, as well as people at truck stops and workers who are involved with the transportation activities.

3.16 Public and Occupational Health

This section describes the affected environment during continued storage with respect to the radiological protection of the public and workers. Public radiation doses from natural and

artificial sources other than spent fuel are also described. This section also describes the regulatory framework for protection from occupational hazards.

3.16.1 Radiological Exposure

Nuclear power plants, spent fuel pools, and at-reactor ISFSIs cause doses to members of the public and onsite workers. The Atomic Energy Act of 1954 requires the NRC to promulgate, inspect, and enforce standards that provide an adequate level of protection for public health and safety. The NRC continuously evaluates the latest radiation protection recommendations from international and national scientific bodies to establish the requirements for nuclear power plant licensees. The NRC has established multiple layers of radiation protection limits to protect the public against potential health risks from exposure to effluent discharges from nuclear power plant operations. If licensees exceed a certain fraction of these dose levels in a calendar quarter, they are required to notify the NRC, investigate the cause, and initiate corrective actions within the specified timeframe (10 CFR 20.2201 and 20.2203).

Nuclear power reactors and their associated spent fuel pools and ISFSIs in the United States are licensed by the NRC and must comply with NRC regulations and conditions specified in the license in order to operate. Licensees are required to comply with 10 CFR Part 20, Subpart C, "Occupational Dose Limits for Adults," and 10 CFR Part 20, Subpart D, "Radiation Dose Limits for Individual Members of the Public." Additionally, the EPA provides environmental radiation protection standards for the uranium fuel cycle in 40 CFR Part 190.

Total effective dose equivalent (TEDE): Sum of the effective dose equivalent (for external exposure) and the committed effective dose equivalent (for internal exposure).

Committed effective dose equivalent (CEDE): Sum of the products of the weighting factors for body organs or tissues that are irradiated and the committed dose equivalent to these organs or tissues.

Deep dose equivalent: Applies to external whole body exposure and is the dose equivalent at a tissue depth of 1 cm (0.39 in.).

3.16.1.1 Regulatory Requirements for Occupational Exposure

A plant licensee must maintain individual doses to workers within the 10 CFR 20.1201 occupational dose limits that are summarized in Table 3-2 and incorporate provisions to maintain doses as low as is reasonably achievable. Under 10 CFR 20.2206, the NRC requires licensees to submit an annual report of the results of individual monitoring carried out by the licensee for each individual for whom monitoring was required by 10 CFR 20.1502 during that year. Annually, the NRC publishes a volume of the results of annual reporting of all licensees in the publicly available NUREG-0713, Volume 32, *Occupational Radiation Exposure at Commercial Nuclear Power Reactors and Other Facilities 2010* (NRC 2012c).

Table 3-2. Occupational Dose Limits for Adults Established by 10 CFR Part 20

Tissue	Dose Limit ^(a)
Whole body or any individual organ or tissue other than the lens of the eye	More limiting of 5 rem/yr TEDE to whole body or 50 rem/yr sum of the deep dose equivalent and the committed dose equivalent to any individual organ or tissue other than the lens of the eye
Lens of the eye	15 rem/yr dose equivalent
Skin of the whole body, or skin of any extremity	50 rem/yr shallow dose equivalent

(a) See text box for definitions.

Note: To convert rem to Sievert, multiply by 0.01.

Under 10 CFR 20.2202 and 20.2203, the NRC requires all licensees to submit reports of all occurrences involving personnel radiation exposures that exceed certain control levels. The control levels are used to investigate occurrences and to take corrective actions as necessary. Depending on the magnitude of the exposure, reporting is required immediately, within 24 hours, or within 30 days.

3.16.1.2 Regulatory Requirements for Public Exposure

During continued storage in spent fuel pools, liquid, gaseous, and solid radioactive waste-management systems would be used to collect and treat the radioactive materials produced as byproducts. These systems would process radioactive liquid, gaseous, and solid effluents to maintain releases within regulatory limits and to levels as low as is reasonably achievable before releasing them to the environment. Waste processing systems are designed to meet the design objectives of 10 CFR Part 50, Appendix I, “Numerical Guides for Design Objectives and Limiting Conditions for Operation to Meet the Criterion ‘As Low as is Reasonably Achievable’ for Radioactive Material in Light-Water-Cooled Nuclear Power Reactor Effluents.”

NRC regulations in 10 CFR 72.104 identify criteria for radioactive materials in effluents and direct radiation from an ISFSI. These criteria include that, for normal operations and anticipated occurrences, the annual dose equivalent to any real individual located beyond the controlled area must not exceed 25 mrem (0.25 mSv) to the whole body, 75 mrem (0.75 mSv) to the thyroid, and 25 mrem (0.25 mSv) to any other critical organ as a result of exposure to planned discharges of radioactive materials, direct radiation, and any other radiation from uranium fuel cycle operations within the region. This regulation also requires that operational restrictions be established to meet as low as is reasonably achievable objectives.

3.16.2 Radiological Exposure from Naturally Occurring and Artificial Sources

Table 3-3 identifies background doses to a typical member of the U.S. population. In the table, the annual values are rounded to the nearest 1 percent. A total average annual effective dose equivalent to members of the U.S. population (i.e., 620 mrem/yr) comes from two primary sources: (1) naturally occurring background radiation and (2) medical exposure to patients.

Table 3-3. Average Annual Effective Dose Equivalent of Ionizing Radiation to a Member of the U.S. Population for 2006

Source	Effective Dose Equivalent	
	mrem	Percent of Total
Ubiquitous background		
Radon and thoron	228	37
Natural		
Cosmic	33	5
Terrestrial	21	3
Internal	29	5
Total ubiquitous background	311	50
Medical		
Computed tomography	147	24
Nuclear medicine	77	12
Interventional fluoroscopy	43	7
Conventional radiography and fluoroscopy	33	5
Total medical	300	48
Consumer products	13	2
Industrial, security, medical, educational and research	0.3	0.05
Occupational	0.5	0.08
Total	624.8	100

Source: Adapted from NCRP 2009

Natural radiation sources other than radon result in 13 percent of the typical radiation dose received. The larger source of radiation dose in ubiquitous background (37 percent) is from radon, particularly because of homes and other buildings that trap radon and significantly enhance its dose contribution over open-air living. The remaining 50 percent of the average annual effective dose equivalent consists of radiation mostly from medical procedures (computed tomography, 24 percent; nuclear medicine, 12 percent; interventional fluoroscopy, 7 percent; and conventional radiography and fluoroscopy, 5 percent) and a small fraction from consumer products (2 percent). The consumer product exposure category includes exposure to members of the public from building materials, commercial air travel, cigarette smoking, mining and agricultural products, combustion of fossil fuels, highway and road construction materials, and glass and ceramic products. The industrial, security, medical, education, and research exposure category includes exposure to the members of the public from nuclear power generation; U.S. Department of Energy (DOE) installations; decommissioning and radioactive waste; industrial, medical, education, and research activities; contact with nuclear medicine patients; and security inspection systems. The occupational exposure category includes

Affected Environment

exposure to workers from medical, aviation, commercial nuclear power, industry and commerce, education and research, government, the DOE, and military installations. Radiation exposures from occupational activities, industrial, security, medical, educational and research contribute insignificantly to the total average effective dose equivalent.

3.16.3 Occupational Hazards

The Occupational Safety and Health Administration (OSHA) is responsible for developing and enforcing workplace safety regulations. OSHA was created by the Occupational Safety and Health Act of 1970, which was enacted to safeguard the health of workers. Facility conditions that result in an occupational risk, but do not affect the safety of licensed radioactive materials, are under the statutory authority of OSHA rather than the NRC as set forth in a Memorandum of Understanding (53 FR 43950) between the NRC and OSHA. Regardless, occupational hazards can be minimized when workers adhere to safety standards and use appropriate protective equipment; however, fatalities and injuries from accidents can still occur.

3.17 References

10 CFR Part 20. *Code of Federal Regulations*, Title 10, *Energy*, Part 20, “Standards for Protection Against Radiation.” Washington, D.C.

10 CFR Part 50. *Code of Federal Regulations*, Title 10, *Energy*, Part 50, “Domestic Licensing of Production and Utilization Facilities.” Washington, D.C.

10 CFR Part 51. *Code of Federal Regulations*, Title 10, *Energy*, Part 51, “Environmental Protection Regulations for Domestic Licensing and Related Regulatory Functions.” Washington, D.C.

10 CFR Part 61. *Code of Federal Regulations*, Title 10, *Energy*, Part 61, “Licensing Requirements for Land Disposal of Radioactive Waste.” Washington, D.C.

10 CFR Part 71. *Code of Federal Regulations*, Title 10, *Energy*, Part 71, “Packaging and Transportation of Radioactive Material.” Washington, D.C.

10 CFR Part 72. *Code of Federal Regulations*, Title 10, *Energy*, “Licensing Requirements for the Independent Storage of Spent Nuclear Fuel, High-Level Radioactive Waste, and Reactor-Related Greater-Than-Class-C Waste.” Washington, D.C.

29 CFR Part 1910. *Code of Federal Regulations*, Title 29, *Labor*, Part 1910, “Occupational Safety and Health Standards.” Washington, D.C.

36 CFR Part 60. *Code of Federal Regulations*, Title 36, *Parks, Forests, and Public Property*, Part 60, “National Register of Historic Places.” Washington, D.C.

36 CFR Part 800. *Code of Federal Regulations*, Title 36, *Parks, Forests, and Public Property*, Part 800, “Protection of Historic Properties.” Washington, D.C.

40 CFR Part 50. *Code of Federal Regulations*, Title 40, *Protection of the Environment*, Part 50, “National Primary and Secondary Ambient Air Quality Standards.” Washington, D.C.

40 CFR Part 51. *Code of Federal Regulations*, Title 40, *Protection of the Environment*, Part 51, “Requirements for Preparation, Adoption, and Submittal of Implementation Plans.” Washington, D.C.

40 CFR Part 81. *Code of Federal Regulations*, Title 40, *Protection of the Environment*, Part 81, “Designation of Areas for Air Quality Planning Purposes.” Washington, D.C.

40 CFR Part 93. *Code of Federal Regulations*, Title 40, *Protection of the Environment*, Part 93, “Determining Conformity of Federal Actions to State or Federal Implementation Plans.” Washington, D.C.

40 CFR Part 190. *Code of Federal Regulations*, Title 40, *Protection of the Environment*, Part 190, “Environmental Radiation Protection Standards for Nuclear Power Operations.” Washington, D.C.

40 CFR Part 261. *Code of Federal Regulations*, Title 40, *Protection of the Environment*, Part 261, “Identification and Listing of Hazardous Waste.” Washington, D.C.

40 CFR Part 423. *Code of Federal Regulations*, Title 40, *Protection of the Environment*, Part 423, “Steam Electric Power Generating Point Source Category.” Washington, D.C.

50 CFR Part 402. *Code of Federal Regulations*, Title 50, *Wildlife and Fisheries*, Part 402, “Interagency Cooperation—Endangered Species Act of 1973, as Amended.” Washington, D.C.

53 FR 43950. October 31, 1988. “Memorandum of Understanding between the Nuclear Regulatory Commission and Occupational Safety and Health Administration; Worker Protection at NRC-licensed Facilities.” *Federal Register*, U.S. Nuclear Regulatory Commission, Washington, D.C.

59 FR 7629. February 16, 1994. “Executive Order 12898: Federal Actions to Address Environmental Justice in Minority Populations and Low-Income Populations.” *Federal Register*, Executive Office of the President, Washington, D.C.

Affected Environment

63 FR 7254. February 12, 1998. "Indian Tribes: Air Quality Planning and Management." *Federal Register*, U.S. Nuclear Regulatory Commission, Washington, D.C.

69 FR 52040. August 24, 2004. "Policy Statement on the Treatment of Environmental Justice Matters in NRC Regulatory and Licensing Actions." *Federal Register*, U.S. Nuclear Regulatory Commission, Washington, D.C.

74 FR 66496. December 15, 2009. "Endangerment and Cause or Contribute Findings for Greenhouse Gases under Section 202(a) of the Clean Air Act." *Federal Register*, U.S. Environmental Protection Agency, Washington, D.C.

76 FR 35512. June 17, 2011. "Decommissioning Planning." *Federal Register*, U.S. Nuclear Regulatory Commission, Washington, D.C.

ACHP (Advisory Council on Historic Preservation). 2008. *National Register Evaluation Criteria*. Washington, D.C. Accession No. ML082880723.

Armantrout, N.B. 1998. *Glossary of Aquatic Habitat Inventory Terminology*. Western Division of American Fisheries Society, Bethesda, Maryland.

Atomic Energy Act of 1954, as amended. 42 USC 2011 *et seq.*

Back, W., J.S. Rosenshein, and P.R. Seaber, eds. 1988. *The Geology of North America: Volume O-2: Hydrogeology*. The Geological Society of America, Boulder, Colorado.

Bald and Golden Eagle Protection Act of 1940, as amended. 16 USC 668-668d *et seq.*

Beeton, A.M. 2002. "Large Freshwater Lakes: Present State, Trends, and Future." *Environmental Conservation* 29(1):21-38, New York, New York.

CEQ (Council on Environmental Quality). 1997. *Environmental Justice: Guidance Under the National Environmental Policy Act*. Executive Office of the President, Washington, D.C.

Available at

http://www.epa.gov/compliance/ej/resources/policy/ej_guidance_nepa_ceq1297.pdf.

Clean Air Act, as amended. 42 USC 7401 *et seq.*

Clean Water Act (See Federal Water Pollution Control Act of 1972).

Coastal Zone Management Act of 1972, as amended. 16 USC 1451 *et seq.*

Columbia County. 2013. "Summary of Assessment and Tax Roll 2012-13." Columbia County, Mt. St. Helens, Oregon. Accession No. ML13099A042.

CYAPC (Connecticut Yankee Atomic Power Company). 2012. *Haddam Neck Plant Independent Spent Fuel Storage Installation Decommissioning Funding Plan*. East Hampton, Connecticut. Accession No. ML123630241.

Edsall, T. and M. Charlton. 1997. *Nearshore Waters of the Great Lakes*. U.S. Environmental Protection Agency and Environment Canada, Washington, D.C. and Downsview, Ontario. Available at http://www.epa.gov/solec/archive/1996/Nearshore_Waters_of_the_Great_Lakes.pdf.

Endangered Species Act of 1973 (ESA), as amended. 16 USC 1531 *et seq.*

EnergySolutions. 2012. *FY 2012/2013 Least Cost Operating Plan Barnwell Disposal Facility*. BEDL-12-024, Barnwell, South Carolina. Available at <http://dms.psc.sc.gov/pdf/matters/0FC14AB1-155D-2817-10B95B39AB319DC1.pdf>.

EPA (U.S. Environmental Protection Agency). 1974. *Information on Levels of Environmental Noise Requisite to Protect Public Health and Welfare with an Adequate Margin of Safety*. 550/9-74-004, Washington, D.C.

EPRI and Maine Yankee. 2005. *Maine Yankee Decommissioning Experience Report: Detailed Experiences 1997-2004*. Palo Alto, California and Wiscasset, Maine. Accession No. ML12088A297.

Federal Water Pollution Control Act of 1972, as amended (also referred to as the Clean Water Act). 33 USC 1251 *et seq.*

Fish and Wildlife Coordination Act of 1934, as amended. 16 USC 661-667e *et seq.*

FWS (U.S. Fish and Wildlife Service). 2007. *National Wetlands Inventory*. U.S. Department of the Interior, Washington, D.C. Available at <http://www.fws.gov/wetlands/index.html>.

GAO (U.S. Government Accountability Office). 2004. *Low-Level Radioactive Waste—Disposal Availability Adequate in Short Term, but Oversight Needed To Identify Any Future Shortfalls*. GAO-04-604, U.S. Nuclear Regulatory Commission, Washington, D.C. Available at <http://www.gao.gov/assets/250/242883.pdf>.

GCRP (U.S. Global Change Research Program). 2014. *Climate Change Impacts in the United States: The Third National Climate Assessment*. J.M. Melillo, T.C. Richmond, and G.W. Yohe, eds. U.S. Government Printing Office, Washington, D.C. Accession No. ML14129A233.

Affected Environment

Hassett-Sipple, B.M. 2011. *National Ambient Air Quality Standards (NAAQS) for Particulate Matter (PM): Current Review—Focus on Primary PM_{2.5} Standards*. EPA/WESTAR Residential Wood Smoke Workshop, Salt Lake City, Utah.

Magnuson-Stevens Fishery Conservation and Management Act, as amended. 16 USC 1801 *et seq.*

Marine Mammal Protection Act of 1972, as amended. 16 USC 1361 *et seq.*

Metz, W. 1983. *Population and Land Use Change in the Vicinity of Operating Nuclear Power Station—An Anthology*. Brookhaven National Laboratory, Upton, New York.

Migratory Bird Treaty Act of 1918, as amended. 16 USC 703–712 *et seq.*

Morrow, J.V. and J.C. Fischenich. 2000. *Habitat Requirements for Freshwater Fishes*. ERDC TN–EMRRPSR–06, U.S. Army Engineer Research and Development Center, Vicksburg, Mississippi. Available at <http://el.erdc.usace.army.mil/elpubs/pdf/sr06.pdf>.

MYAPC (Maine Yankee Atomic Power Company). 2013. *Maine Yankee Independent Spent Fuel Storage Installation Revised Decommissioning Funding Plan*. Wiscasset, Maine. Accession No. ML130460347.

National Environmental Policy Act of 1969 (NEPA), as amended. USC 4321 *et seq.*

National Historic Preservation Act of 1966 (NHPA), as amended. 16 USC 470 *et seq.*

NCRP (National Council on Radiation Protection and Measurements). 2009. *Ionizing Radiation Exposure of the Population of the United States*. Report 160, Bethesda, Maryland.

NEI (Nuclear Energy Institute). 2013. *Low-Level Radioactive Waste*. Washington, D.C. Accession No. ML13100A276.

Northcote, T.G. 1978. “Migratory strategies and production in freshwater fishes.” In S.D. Gerking, ed., *Ecology of Freshwater Fish Production*, Blackwell Science, Oxford, England.

NRC (U.S. Nuclear Regulatory Commission). 1985. *Environmental Assessment Related to the Construction and Operation of the Surry Dry Cask Independent Spent Fuel Storage Installation*. Washington, D.C. Accession No. ML062400262.

NRC (U.S. Nuclear Regulatory Commission). 1988. *Environmental Assessment Related to the Construction and Operation of the Oconee Nuclear Station Independent Spent Fuel Storage Installation*. Washington, D.C. Accession No. ML123480209.

NRC (U.S. Nuclear Regulatory Commission). 1989. *Environmental Assessment and Finding of No Significant Impact for Proposed Rule Entitled, "Storage of Spent Nuclear Fuel in NRC-Approved Storage Casks at Nuclear Power Reactor Sites."* Washington, D.C. Accession No. ML051230231.

NRC (U.S. Nuclear Regulatory Commission). 1991a. *Environmental Assessment Related to Construction and Operation of the Fort St. Vrain Independent Spent Fuel Storage Installation.* Docket No. 72-009, Public Service Company of Colorado, Washington, D.C. Accession No. ML062710252.

NRC (U.S. Nuclear Regulatory Commission). 1991b. *Environmental Assessment Related to the Construction and Operation of the Calvert Cliffs Independent Spent Fuel Storage Installation.* Washington, D.C. Accession No. ML022550053.

NRC (U.S. Nuclear Regulatory Commission). 1992. *Environmental Assessment Related to Construction and Operation of the Prairie Island Independent Spent Fuel Storage Installation.* Washington, D.C. Accession No. ML090260415.

NRC (U.S. Nuclear Regulatory Commission). 2002. *Final Generic Environmental Impact Statement on Decommissioning of Nuclear Facilities, Supplement 1 Regarding the Decommissioning of Nuclear Power Reactors.* NUREG-0586, Volumes 1 and 2, Washington, D.C. Accession Nos. ML023470327, ML023500228.

NRC (U.S. Nuclear Regulatory Commission). 2003. *Environmental Assessment Related to the Construction and Operation of the Diablo Canyon Independent Spent Fuel Storage Installation.* Washington, D.C. Accession No. ML032970370.

NRC (U.S. Nuclear Regulatory Commission). 2004. *Environmental Assessment for the License Renewal of the General Electric Morris Operation Independent Spent Fuel Storage Installation in Morris, Illinois.* Washington, D.C. Accession No. ML043360415.

NRC (U.S. Nuclear Regulatory Commission). 2005a. *Environmental Assessment Related to the Renewal of the H.B. Robinson Steam Electric Plant, Unit No. 2 Independent Spent Fuel Storage Installation License Special Nuclear Materials License No. SNM-2502.* Washington, D.C. Accession No. ML050700137.

NRC (U.S. Nuclear Regulatory Commission). 2005b. *Environmental Assessment Related to the Renewal of the License for the Surry Independent Spent Fuel Storage Installation.* Washington, D.C. Accession No. ML040560238.

Affected Environment

NRC (U.S. Nuclear Regulatory Commission). 2005c. *Environmental Assessment Related to the Construction and Operation of the Humboldt Bay Independent Spent Fuel Storage Installation*. Washington, D.C. Accession No. ML052430106.

NRC (U.S. Nuclear Regulatory Commission). 2008. *North Anna Independent Spent Fuel Storage Installation, Final Safety Analysis Report*. Revision 6, Washington, D.C. Accession No. ML110180557.

NRC (U.S. Nuclear Regulatory Commission). 2009a. *Environmental Assessment for the Renewal of U.S. Nuclear Regulatory Commission License No. SNM-2503 for Oconee Nuclear Power Station Independent Spent Fuel Storage Installation*. Washington, D.C. Accession No. ML091340557.

NRC. (U.S. Nuclear Regulatory Commission). 2009b. "Memorandum and Order in the Matter of Duke Energy Carolinas, LLC and Tennessee Valley Authority [Greenhouse Gas Emissions]." CLI-09-21, Washington, D.C. Accession No. ML093070690.

NRC (U.S. Nuclear Regulatory Commission). 2011. Policy Issue (Information) from R.W. Borhardt to The Commissioners dated February 9, 2011, regarding "Senior Management Review of Overall Regulatory Approach to Groundwater Protection." SECY-11-0019, Washington, D.C. Accession No. ML110050525.

NRC (U.S. Nuclear Regulatory Commission). 2012a. *Environmental Assessment for the Proposed Renewal of U.S. Nuclear Regulatory Commission License No. SNM-2505 for Calvert Cliffs Nuclear Power Plant, LLC's Independent Spent Fuel Storage Installation*. Washington, D.C. Accession No. ML121220084.

NRC (U.S. Nuclear Regulatory Commission). 2012b. *Predecisional Draft—Proposed Draft Guidance Decommissioning Planning During Operations*. Washington, D.C. Accession No. ML12179A246.

NRC (U.S. Nuclear Regulatory Commission). 2012c. *Occupational Radiation Exposure at Commercial Nuclear Power Reactors and Other Facilities 2010: Forty-Third Annual Report*. NUREG-0713, Volume 32, Washington, D.C. Accession No. ML120950282.

NRC (U.S. Nuclear Regulatory Commission). 2013a. *Generic Environmental Impact Statement for License Renewal of Nuclear Plants*. NUREG-1437, Revision 1, Washington, D.C. Accession No. ML13107A023.

NRC (U.S. Nuclear Regulatory Commission). 2013b. *2013-2014 Information Digest*. NUREG-1350, Volume 25, Washington, D.C. Accession No. ML13241A207.

NRC (U.S. Nuclear Regulatory Commission). 2013c. *Attachment 1—Staff Guidance for Greenhouse Gas and Climate Change Impacts for New Reactor Environmental Impact Statements*. COL/ESP-ISG-026, Washington, D.C. Accession No. ML12326A811.

NRC (U.S. Nuclear Regulatory Commission). 2013d. *List of Historical Leaks and Spills at U.S. Commercial Nuclear Power Plants*. Revision 12, Washington, D.C. Accession No. ML101270439.

NRC (U.S. Nuclear Regulatory Commission). 2013e. *Environmental Impact Statement for Combined Licenses (COL) for Enrico Fermi Unit 3 Final Report*. NUREG–2105, Volumes 1 and 2, Washington, D.C. Accession Nos. ML12307A172, ML12307A176.

Occupational Safety and Health Act of 1970. 29 USC 651 *et seq.*

PG&E (Pacific Gas and Electric Company). 2012. “PG&E Making \$157 Million in Property Tax Payments to 49 California Counties.” News and Perspectives from Pacific Gas and Electric Company, San Francisco, California. Accession No. ML13099A045.

Pollution Prevention Act of 1990. 42 USC 13101 *et seq.* (1990).

Resource Conservation and Recovery Act of 1976 (RCRA). 42 USC 6901 *et seq.*

Safe Drinking Water Act, as amended. 42 USC 300f. *et seq.*

TCC (Texas Low Level Radioactive Waste Disposal Compact Commission). 2014. Imports. Austin, Texas. Available at <http://www.tllrwfcc.org/imports>.

Todd, D.K. 1960. *Groundwater Hydrology*. Second Edition, New York, New York.

USCB (U.S. Census Bureau). 2007. *Current Population Reports*. Series P60, Washington, D.C. Available at <http://www.census.gov/main/www/cprs.html>.

Williams, J.D., M.L. Warren, K.S. Cummings, J.L. Harris, and R.J. Neves. 1993. “Conservation Status of Freshwater Mussels of the United States and Canada.” *Fisheries* 18:6–22, Philadelphia, Pennsylvania.

Witman, J.D. 1987. “Subtidal Coexistence: Storms, Grazing, Mutualism, and the Zonation of Kelps and Mussels.” *Ecological Monographs* 55:421–445, Ithaca, New York.

4.0 Environmental Impacts of At-Reactor Continued Storage of Spent Fuel

This chapter evaluates the environmental impacts of continued at-reactor storage of spent nuclear fuel (spent fuel) in a spent fuel pool or independent spent fuel storage installation (ISFSI). The U.S. Nuclear Regulatory Commission (NRC) evaluated the environmental impacts of at-reactor continued storage for three timeframes: short-term storage, long-term storage, and indefinite storage. Chapter 2 provides descriptions of the various activities that occur during continued storage. The environmental impacts of away-from-reactor ISFSI storage are evaluated in Chapter 5.

In the short-term storage timeframe, the NRC evaluates the impacts of continued storage of spent fuel for 60 years beyond the licensed life for operations of a reference reactor. The NRC assumes that all spent fuel has been transferred from the spent fuel pool to an ISFSI by the end of this 60-year timeframe. The NRC also assumes that a repository becomes available by the end of this 60-year timeframe.

Short-term storage of spent fuel for 60 years beyond licensed life for operations includes the following:

- continued storage of spent fuel in spent fuel pools (at-reactor only) and ISFSIs,
- routine maintenance of spent fuel pools and ISFSIs (e.g., maintenance of concrete pads), and
- handling and transfer of spent fuel from spent fuel pools to ISFSIs.

The NRC then evaluates the impacts of continued storage for another 100 years after short-term storage. This 100-year timeframe is referred to as the long-term storage timeframe. The *Generic Environmental Impact Statement for Continued Storage of Spent Nuclear Fuel* (GEIS) assumes that a repository would become available by the end of the 100-year timeframe (160 years total continued storage after the end of the reactor's licensed life for operation).

Long-term storage activities include the following:

- continued storage of spent fuel in ISFSIs, including routine maintenance,
- one-time replacement of ISFSIs and spent fuel canisters and casks, and
- construction and operation of a dry transfer system (DTS) (including replacement).

The NRC also evaluates the environmental impacts of a third timeframe that assumes a repository does not become available, thus requiring onsite storage in spent fuel pools until the

Environmental Impacts of At-Reactor Continued Storage of Spent Fuel

end of the short-term storage timeframe and storage in ISFSIs indefinitely. The activities during the indefinite storage timeframe are the same as those that would occur for long-term storage; however, without a repository these activities occur repeatedly. Figure 1-1 provides a graphical representation of the three timeframes.

Section 1.8.3 provides a list of the assumptions made in this GEIS regarding continued storage. Impacts from decommissioning the spent fuel pool, ISFSI, and DTS are not evaluated in this chapter but are considered in the cumulative impacts analysis in Chapter 6, as are the impacts from spent fuel transportation to a repository. Construction of a new spent fuel pool cooling system, to support decommissioning, is also addressed in the cumulative impacts analysis. The environmental impacts of operating a new cooling system during continued storage are bounded by the impacts of an operating reactor and are therefore not discussed further in this chapter. The NRC assumes that the initial at-reactor ISFSIs would be constructed under a general or site-specific license during the term of reactor operations (including license renewal); therefore, the construction impacts of these initial at-reactor ISFSIs are not specifically analyzed in this GEIS, but are taken into account in establishing the baseline affected environment described in Chapter 3. These ISFSIs would, however, be subject to periodic relicensing reviews and accompanying environmental reviews under the National Environmental Policy Act of 1969 (NEPA). Further, the NRC assumes that the ISFSIs are completely replaced every 100 years. This replacement activity would require separate site-specific authorization from the NRC before the start of any replacement activities. NRC authorization to relicense or replace an ISFSI and NRC authorization to construct, operate, and replace a DTS are separate licensing actions that would require an NRC review. They are considered Federal actions under NEPA and would be undertakings under the National Historic Preservation Act (NHPA).

As discussed in Chapter 2, there are two existing away-from-reactor ISFSIs—the GEH Morris and Three Mile Island Unit 2 (TMI-2) ISFSIs. However, as explained below, the environmental impacts described in this chapter for at-reactor ISFSIs are representative of the impacts at both of these away-from-reactor ISFSIs.

- The GEH Morris ISFSI is at the site of a spent fuel reprocessing facility (a production facility) that was constructed by General Electric, but never operated. Because it was to be a production facility licensed under siting and safety requirements similar to those for reactors (e.g., Title 10 of the *Code of Federal Regulations* Part 50 [10 CFR Part 50], “Domestic Licensing of Production and Utilization Facilities”), the GEH Morris facility is sited and constructed in a manner substantially similar to a reactor spent fuel pool. In fact, it is currently licensed to store 352 pressurized water reactor (PWR) fuel assemblies and 2,865 boiling water reactor (BWR) fuel assemblies, for a total of about 714 MTU, which is no more than the licensed capacity of many BWR spent fuel pools. Therefore, the environmental impacts described in the following chapters of this GEIS for at-reactor spent fuel pools are representative of the impacts at the GEH Morris facility.

- The TMI-2 ISFSI is a modified NUHOMS spent fuel storage system (designated NUHOMS-12T) with 30 horizontal storage modules (DOE 2012). It was licensed by the NRC in March 1999 and contains spent fuel from the damaged TMI-2 reactor (a single reactor core). Although the NUHOMS-12T storage module contents are core debris (not fuel assemblies) and the debris storage canisters could not be treated like fuel cladding, the design of the NUHOMS-12T accounts for these technical differences. Each NUHOMS-12T module provides for the horizontal dry storage of up to 12 TMI-2 stainless-steel canisters inside a dry shielded canister, which is placed inside a concrete horizontal storage module. The NUHOMS-12T modification includes venting of the dry shielded canister through high-efficiency particulate air grade filters during storage. The vent system allows for release of hydrogen gas, generated due to radiolysis, and monitoring and/or purging of the system during operation (DOE 2012). The TMI-2 ISFSI is actually no larger than a typical at-reactor ISFSI and meets the same NRC regulatory standards as at-reactor ISFSIs. Therefore, the environmental impacts described in this chapter for at-reactor ISFSIs are representative of the impacts at the TMI-2 ISFSI.

In this chapter, the NRC uses the License Renewal GEIS (NRC 2013a) to inform some of the impact determinations regarding continued storage. In many of these cases, the analysis in this GEIS considers how the environmental impacts of continued storage compare to the impacts considered in the License Renewal GEIS. In the License Renewal GEIS, the NRC evaluated the potential impacts in each resource area by reviewing previous environmental analyses for past license renewal reviews, scientific literature, and other available information. Where appropriate, this GEIS also considers analyses and impact determinations made in previous ISFSI licensing and renewal environmental assessments (EA) and environmental impact statements (EISs) and in reactor license renewal and new reactor licensing EISs to inform the impact determinations in this analysis.

Sections 4.1 through 4.17 evaluate the potential impacts on various resource areas, such as land use, air quality, water quality, transportation, and public health. Sections 4.18 and 4.19 discuss accidents and terrorism. Section 4.20 provides a summary of the environmental impacts and Section 4.21 contains the references. Within each resource area, the NRC has provided an analysis of the potential impacts for the short-term storage timeframe, the long-term storage timeframe, and indefinite storage and provided an impact determination—SMALL, MODERATE, or LARGE—for each timeframe. The definitions of SMALL, MODERATE, and LARGE are provided in Section 1.8.5. For some resource areas, the impact determination language is specific to the authorizing regulation, executive order, or guidance.

4.1 Land Use

This section describes land-use impacts caused by the continued storage of spent fuel in spent fuel pools and at-reactor ISFSIs.

4.1.1 Short-Term Storage

Spent fuel pool operations during the short-term storage timeframe would not require the use of any land beyond that which was cleared and graded during nuclear power plant construction. Continued operation of the spent fuel pool during short-term storage is not anticipated to require new or additional monitoring or maintenance activities that would affect current land use. In addition, inspection, testing, and surveillance activities that are conducted throughout the life of spent fuel pools necessary to ensure compliance with Federal, State, and local requirements regarding the environment and public safety are not expected to affect land-use conditions (NRC 2013a).

As described in Section 3.1, most nuclear power plant sites have constructed ISFSIs for onsite dry cask storage of spent fuel. Dry cask storage at operating nuclear power plant sites provides supplemental storage for portions of the spent fuel pool inventory. As further described in Section 3.1, only a small fraction of the land committed for a nuclear power plant is required to construct and operate an ISFSI (see Table 3-1).

Operation of an ISFSI involves removing the spent fuel from spent fuel pools, packaging the spent fuel in dry casks, and placing the dry casks on concrete storage pads. ISFSI operations would not require the use of any land beyond that which was cleared and graded during facility construction. The ISFSI would be surrounded by security fencing to restrict and control access in accordance with requirements for the protection of stored spent fuel in 10 CFR 73.51. Only a small portion of the land committed for a nuclear power plant is required for an at-reactor ISFSI (see Table 3-1). Therefore, access restrictions associated with operation of an ISFSI during the short-term storage timeframe would affect only a small amount of land within the larger nuclear plant site.

ISFSIs are designed as passive systems that require no power or regular maintenance other than routine visual inspections and checks of the cask ventilation system (e.g., for blockages of ducts). Continued operation of an at-reactor ISFSI is not anticipated to require new or additional maintenance activities that would affect current land use. The NRC has prepared several EAs for site-specific licenses for construction and operation of at-reactor ISFSIs (NRC 2012a, 2005a, 2003, and 1992).

Based on the assessment above, 60 years of continued at-reactor storage in a spent fuel pool or at-reactor ISFSI would not require disturbance of any new land at a nuclear power plant or result in operational or maintenance activities that would change the current land use. Therefore, the NRC concludes that the potential environmental impact on land use would be SMALL during the short-term storage timeframe.

4.1.2 Long-Term Storage

The potential environmental impacts on land use from long-term storage in an ISFSI would be similar to those described for short-term storage. Only a small fraction of the land committed for a nuclear power plant is required for an ISFSI (see Table 3-1). Operation and maintenance of an ISFSI would not require the use of any land beyond that which was already cleared and graded during facility construction. Access restrictions associated with operation of an ISFSI during the long-term storage timeframe would affect only a small amount of land within the larger nuclear plant site.

During long-term storage, in addition to routine maintenance and monitoring, the NRC assumes that a DTS is constructed and operated to facilitate the transfer, handling, and repackaging of spent fuel after the end of the short-term timeframe. As described in Section 2.1.4, the reference DTS considered in this GEIS consists of two major structures: (1) a two-level concrete and steel structure that provides confinement and shielding during fuel-transfer, handling, and repackaging operations and (2) an attached, single-level steel building for receipt and handling of the spent fuel transportation packages. These two major structures would be constructed on a reinforced-concrete basemat that would occupy about 0.04 ha (0.1 ac). Maintenance and monitoring activities associated with a DTS would include routine inspections and testing of the spent fuel and cask transfer and handling equipment (e.g., lift platforms and associated mechanical equipment) and process and effluent radiation monitoring, which do not require the use of any land beyond that which would be cleared and graded during DTS construction.

As described in Section 3.1, the physical area required for operating a commercial nuclear power plant site ranges from 34 ha (84 ac) to 5,700 ha (14,000 ac) (NRC 2013a). Therefore, only a small fraction of the land committed for a nuclear power plant would be required to construct and operate a DTS. Once the DTS is constructed, access to the facility site would be restricted, in accordance with 10 CFR Part 73, to activities that support facility operations. The restricted access area for the reference DTS described in Section 2.1.4 is about 0.7 ha (2 ac).

The NRC assumes that the at-reactor ISFSI and DTS would be replaced during the long-term storage timeframe. The number of storage casks that would be replaced and the size of the replacement concrete storage pad would depend on the remaining inventory of spent fuel to be transported to a permanent repository after the 100-year timeframe. The replacement facilities for the at-reactor ISFSI and DTS would be constructed on land near the existing facilities.

Long-term storage of spent fuel at an at-reactor ISFSI would not result in operational or maintenance activities that would change land-use conditions. Construction and operation of a DTS and replacement of the ISFSI and DTS would affect a small fraction of the land already committed for a nuclear power plant. Therefore, the NRC concludes that the environmental impacts on land use during the long-term storage timeframe would be SMALL.

4.1.3 Indefinite Storage

This section describes the potential environmental impacts on land use if a repository is not available to accept spent fuel. For this analysis, the NRC assumes that spent fuel would continue to be stored in at-reactor ISFSIs indefinitely. The potential environmental impacts on land use from indefinite storage would be similar to those described for long-term storage.

Aging management is assumed to include replacement of the ISFSI and DTS every 100 years and necessitate repackaging of spent fuel at a DTS. Replacement of the ISFSI and DTS would occur on land near existing facilities. The older ISFSI and DTS would be demolished, and the land reclaimed.

Access to the ISFSI and DTS would be restricted to activities that support facilities operations in accordance with 10 CFR Part 73. Restricted access under the indefinite storage timeframe would result in land that would not be available for other productive land uses for an indefinite amount of time. However, as noted previously, only a small portion of the land already committed for a nuclear power plant is required for an at-reactor ISFSI and DTS. Therefore, the amount of land that would not be available for other land uses under the indefinite storage timeframe would be small.

Indefinite storage of spent fuel in at-reactor ISFSI facilities would not result in operational or maintenance activities that would change land-use conditions. Construction of a DTS and replacement of the ISFSI and DTS every 100 years would affect a small fraction of the nuclear plant site. After replacement, the older ISFSI and DTS would be demolished and the land would be reclaimed. Therefore, the NRC concludes that the environmental impacts on land use from indefinite storage would be SMALL.

4.2 Socioeconomics

This section describes the socioeconomic factors that could be directly or indirectly affected by continued storage of spent fuel in spent fuel pools and at-reactor ISFSIs. Changes in employment and tax payments caused by continued storage can have a direct and indirect effect on public services and housing demand, as well as traffic volumes in the communities in the region around each nuclear power plant site. As discussed in Chapter 3, the socioeconomic region of influence is where spent fuel storage workers and their families reside, spend their income, and use their benefits, thus directly and indirectly affecting the economic conditions of the region.

4.2.1 Short-Term Storage

During the short-term storage timeframe, some systems used during reactor operations would remain in operation to ensure spent fuel pool cooling prior to the transfer of spent fuel from the

pools to an at-reactor ISFSI. A small number of workers—likely between 20 and 85—would continue to maintain, monitor, and transfer spent fuel from spent fuel pools to an at-reactor ISFSI after the cessation of reactor operations. A small number of workers (30–35) would also continue to maintain and monitor the at-reactor ISFSI. Because the existing storage workforce would remain to monitor and maintain storage facilities after reactor operations cease, there would be no need for any additional spent fuel pool and at-reactor operations workers.¹ Therefore, there would be no increase in demand for housing and public services because of continued storage. Continued storage activities are also not likely to affect local transportation conditions in the vicinity of the storage facility. Transportation activities would continue at reduced levels after the cessation of reactor operations as spent fuel storage operations and decommissioning workers would continue to commute to the site. The number of commuting storage operations workers, however, would be reduced after all spent fuel has been transferred from the pool to an ISFSI.

The amount of tax payments during the short-term storage timeframe would depend on a number of factors, including State tax law and established tax payment agreements with local tax authorities. Property tax and other payments, including the portion for at-reactor spent fuel storage, would continue, although the amount of tax payments would likely be reduced after reactor operations cease. Nevertheless, the amount of tax payments related to continued storage is not expected to change during the short-term timeframe.

The socioeconomic effects of reactor operations have become well established as regional socioeconomic conditions have adjusted to the presence of the nuclear power plant. During the period of reactor operations local communities have adjusted to fluctuations in workforce caused by regularly scheduled refueling and maintenance outages (NRC 2013a). By comparison, the contributory effect on socioeconomic conditions from continued short-term spent fuel storage would be SMALL, because (1) the number of storage operations workers required to maintain and monitor spent fuel storage in pools or an at-reactor ISFSI is very small, (2) tax payments would continue, and (3) there would be no increased demand for housing and public services. Any reduction in State and local taxes paid by the licensee would be directly attributable to the cessation of reactor operations and the reduced value of the property rather than to continued storage. Therefore, the socioeconomic impacts of continued onsite storage during the short-term timeframe would be SMALL.

4.2.2 Long-Term Storage

As discussed in Section 2.1.4, in contrast to short-term storage, long-term storage of spent fuel would require the construction and operation of a DTS and replacement of the DTS and ISFSI.

¹ Typically shutdown units that are co-located with operating units either have a small dedicated staff or have workers from the operating units assigned and dedicated to the shutdown unit (e.g., spent fuel pool maintenance and monitoring activities).

Environmental Impacts of At-Reactor Continued Storage of Spent Fuel

The construction of a DTS and replacement at-reactor ISFSI would require a much smaller workforce than required for nuclear power plant construction or extended maintenance and refueling outages. As discussed in Section 3.2 of this GEIS, the construction workforce for an at-reactor ISFSI ranged from approximately 20 to 60 workers over approximately 1 year. The reference DTS is a two-level concrete and steel structure with an attached single-level, weather-resistant, pre-engineered steel building on 0.04 ha (0.1 ac). With regard to the workforce required for the construction of the DTS, the NRC reviewed a proposal to construct and operate a 3.2-ha (8-ac) spent fuel-transfer facility at the Idaho National Laboratory (NRC 2004a). The proposal estimated 250 construction workers would be employed for 2 years. Given that the Idaho National Laboratory facility is an estimated 80 times larger than the Transnuclear, Inc.-Electric Power Research Institute (Transnuclear-EPRI) DTS design, the NRC estimates that no more than 60 to 80 short-term construction workers would be needed for between 1 to 2 years to build the DTS and at-reactor ISFSI pad. The construction workforce would likely be composed of local workers. Given the small number of workers, short construction timeframe, and the availability of housing, there would likely be no noticeable increase in the demand for permanent housing.

Similar to short-term storage, a small number of workers (30–35) would continue to maintain and monitor the storage of spent fuel in the at-reactor ISFSI. The ISFSI workforce requirements would remain unchanged from the period of reactor operations. Therefore, continued storage would not create any increased demand for housing or public services. In addition, activities associated with long-term storage are also not likely to affect local transportation conditions in the vicinity of the continued storage site.

Similar to short-term timeframe, tax payments during the long-term timeframe would depend on a number of factors, including State tax law and established tax payment agreements with local tax authorities. Property tax and other payments, including the portion for continued at-reactor storage, would continue during the long-term timeframe. The replacement of the at-reactor ISFSI and construction, operation, and subsequent replacement of the DTS could be viewed as property improvements by local tax assessors causing the amount of the property tax payment to be increased. However, construction activities are expected to have a minor effect on the local economy. Nevertheless, even with the addition of a DTS, the amount of tax payments related to continued storage is not expected to significantly change during the long-term timeframe.

As previously noted for short-term storage, regional socioeconomic conditions have become well established during the period of reactor operations for all nuclear power plants (NRC 2013a). By comparison, the contributory effect from long-term storage would be SMALL for all socioeconomic categories because (1) few workers will be required to maintain and monitor spent fuel storage, construct and operate a DTS, and replace the at-reactor ISFSI and DTS; (2) construction activities will be of short duration; (3) continued tax payments will remain relatively unchanged; and (4) there will be no increased demand for housing and public

services. Therefore, the NRC concludes that the socioeconomic impacts of continued storage during the long-term timeframe would be SMALL.

4.2.3 Indefinite Storage

This section describes the socioeconomic impacts if a repository is not available to accept spent fuel from an existing nuclear power plant site. With no repository available, an at-reactor ISFSI would be continuously monitored and maintained. Impacts from indefinite storage would be similar to those described for long-term storage. The NRC assumes the ISFSI pads and DTS would be replaced every 100 years and that this would require a small workforce. Property tax revenue would remain relatively unchanged while spent fuel remains stored onsite. Therefore, the socioeconomic impacts of continued indefinite onsite storage would be SMALL.

4.3 Environmental Justice

This section describes the potential human health and environmental effects from the continued onsite storage of spent fuel in spent fuel pools and at-reactor ISFSIs on minority and low-income populations living in the vicinity of nuclear power plant sites.

The NRC strives to identify and consider environmental justice issues in agency licensing and regulatory actions primarily by fulfilling its NEPA responsibilities for these actions. Under Executive Order 12898 (59 FR 7629), Federal agencies are responsible for identifying and addressing potential disproportionately high and adverse human health and environmental impacts on minority and low-income populations. Environmental justice refers to a Federal policy that ensures that minority, low-income, and tribal communities that have historically been excluded from environmental decision-making are given equal opportunities to participate in decision-making processes.

In 2004, the Commission issued a Policy Statement on the Treatment of Environmental Justice Matters in NRC Regulatory and Licensing Actions (69 FR 52040), which states, "The Commission is committed to the general goals set forth in Executive Order 12898, and strives to meet those goals as part of its National Environmental Policy Act (NEPA) review process." In addition, the Commission stated in its decision on the Private Fuel Storage (PFS) facility application that environmental justice, as applied at the NRC, "means that the agency will make an effort under NEPA to become aware of the demographic and economic circumstances of local communities where nuclear facilities are to be sited, and take care to mitigate or avoid special impacts attributable to the special character of the community" (NRC 2002a, 2004b).

The NRC normally addresses environmental justice issues and concerns by first identifying potentially affected minority and low-income populations and then determining whether there would be any potential human health or environmental effects and whether these effects may be disproportionately high and adverse in site-specific licensing actions. Adverse health effects are

Environmental Impacts of At-Reactor Continued Storage of Spent Fuel

measured in terms of the risk and rate of fatal or nonfatal adverse impacts on human health. Disproportionately high and adverse human health effects occur when the risk or rate of exposure to an environmental hazard for a minority or low-income population is significant and exceeds the risk or exposure rate for the general population or for another appropriate comparison group. Disproportionately high environmental effects refer to impacts or risks of impacts on the natural or physical environment in a minority or low-income community that are significant and appreciably exceed the environmental impact on the larger community.

Potential impacts on minority and low-income populations as the nuclear power plant transitions from reactor operations to decommissioning and continued storage would mostly consist of radiological (human health) and socioeconomic (environmental) effects. During continued storage, the incremental radiation dose from spent fuel stored in spent fuel pools and at-reactor ISFSIs is expected to remain unchanged from the period of reactor operations and within regulatory limits (see Section 4.17). Radiological and environmental monitoring programs, similar to those implemented during nuclear power plant operations, would ensure that the radiation dose from continued spent fuel storage would remain within regulatory limits. In addition, socioeconomic conditions affected by the continued storage of spent fuel as they relate to minority and low-income populations living near nuclear power plant sites would remain unchanged. Because spent nuclear fuel is already being stored in spent fuel pools and ISFSIs (where available) at all commercial nuclear power plants in the United States, the continued storage of spent fuel would not create any new effect on minority and low-income populations beyond what is currently being experienced during reactor operations.

As discussed in Section 3.3, the special pathway receptors analysis is an important part of the environmental justice analysis because consumption patterns may reflect the traditional or cultural practices of minority and low-income populations in the area of the continued storage site, such as migrant workers or Native Americans. All NRC licensees have to assess the impact of facility operations on the environment through their radiological environmental monitoring programs (REMPs). These programs assess the effects of site operations on the environment that could affect special pathway receptors. However, once reactor operations cease, the REMP would be modified to consider only the potential sources of radiation and radioactivity that may be released from a spent fuel pool or an at-reactor ISFSI. Air monitoring, thermoluminescent dosimeters, and groundwater monitoring would likely be used to detect releases from the spent fuel pools and at-reactor ISFSI, but collection of other environmental sampling data would depend on site-specific conditions (e.g., proximity to surface waterbody).

In most cases, NRC environmental justice analyses are limited to evaluating the human health effects of the proposed licensing action and the potential for minority and low-income populations to be affected. As explained in the Commission's policy statement, environmental justice-related issues as well as demographic conditions (i.e., the presence of potentially affected minority and low-income populations) differ from site to site, and environmental justice issues and concerns usually cannot be resolved generically with regard to NRC licensing

actions. Consequently, environmental justice, as well as other socioeconomic issues, is normally considered in site-specific environmental reviews (69 FR 52040). However, the NRC has determined that a generic analysis of the human health and environmental effects of continued storage on minority and low-income populations is possible, because minority and low-income populations are not expected to experience disproportionately high and adverse human health and environmental effects from the continued storage of spent fuel.

As previously stated in Chapters 2 and 3, this GEIS and the Rule are not licensing actions and do not authorize the continued storage of spent fuel. The environmental analysis in this GEIS fulfills a small part of the NRC's NEPA obligation with respect to the licensing or relicensing of a nuclear reactor or spent fuel storage facility. Further, for site-specific licenses, the NEPA analysis would include consideration of environmental justice prior to any NRC licensing action. As with other resource areas, a site-specific analysis allows the NRC to make an impact determination for each NRC licensing action. A generic determination of the human health and environmental effects during continued storage is possible because the NRC has evaluated how environmental effects change when a nuclear power plant site transitions from reactor operations to decommissioning. Based on this knowledge, the NRC can provide a generic assessment of the potential human health and environmental effects during continued storage.

4.3.1 Short-Term Storage

As previously explained in Section 4.2.1, the socioeconomic effects of reactor operations have become well established because regional socioeconomic conditions will have adjusted to the presence of the nuclear power plant (NRC 2013a). After the cessation of reactor operations, a small number of workers (20–85) would continue to maintain and monitor spent fuel pools. These workers would also transfer spent fuel from the spent fuel pools to an at-reactor ISFSI. Once all of the spent fuel is transferred from the spent fuel pools to dry cask storage, spent fuel pool storage operations worker positions would be eliminated. For at-reactor ISFSIs, a small number of workers (30–35) would be needed to maintain and monitor the ISFSI. Consequently, socioeconomic impacts due to continued storage would be unchanged in comparison to the period of reactor operations for minority and low-income populations.

Generally, the continued maintenance and radiological monitoring associated with spent fuel storage, either in spent fuel pools or at-reactor ISFSIs, during the short-term timeframe ensures that any human health and environmental effects would remain within regulatory limits for the general population. Based on a review of recent REMP reports, human health impacts would not be expected in special pathway receptor populations living near a nuclear power plant site as a result of subsistence consumption of water, local food, fish, and wildlife during the short-term timeframe. A modified REMP would remain in effect after the nuclear power plant ceases operations through the short-term timeframe. Monitoring would confirm that radiological doses would remain within regulatory limits and minority and low-income populations would

Environmental Impacts of At-Reactor Continued Storage of Spent Fuel

experience no new human health and environmental effects during the short timeframe beyond what had already been experienced during reactor operations.

As discussed for the other resource areas in Chapter 4, overall human health and environmental effects from continued storage during the short-term timeframe would be limited in scope and SMALL for all populations. Therefore, minority and low-income populations are not expected to experience disproportionately high and adverse human health and environmental effects during this timeframe. In addition, as indicated in the Commission's policy statement, environmental justice impacts would also be considered during site-specific environmental reviews for specific licensing actions (69 FR 52040).

4.3.2 Long-Term Storage

In addition to monitoring and maintenance, long-term storage includes the construction and operation of a DTS and replacement of the at-reactor ISFSI and DTS. Construction and operation of a DTS would constitute a Federal action under NEPA and site-specific analysis would include an analysis of the potential effects on minority and low-income populations. NRC environmental justice analyses are generally limited to evaluating the human health and environmental effects of the proposed licensing action and the potential for minority and low-income populations to be disproportionately affected. As stated in the NRC policy statement, environmental justice assessments would be performed as necessary in the underlying licensing action for each particular facility (69 FR 52040). DTS license reviews would not rely on the analysis in this GEIS, because the site-specific NEPA analysis would consider the site-specific impacts on minority and low-income populations.

Potential impacts on minority and low-income populations from the construction, operation, and replacement of the DTS and at-reactor ISFSI would mostly consist of environmental and socioeconomic effects during construction (e.g., noise, dust, traffic, employment, and housing impacts). Noise and dust impacts during construction would be short term and primarily limited to onsite activities. Minority and low-income populations residing along site access roads could be directly affected by increased commuter vehicle and truck traffic. However, because of the temporary nature of construction and the relatively low numbers of workers (60–80 short-term construction workers), these effects are likely to be minimal and limited in duration. Increased demand for rental housing during construction could cause rental costs to rise temporarily, disproportionately affecting low-income populations living near the site who rely on inexpensive housing. However, given the short duration of construction (1–2 years), the relatively small number of workers needed, and the proximity of some nuclear power plant sites to metropolitan areas, it is expected that many of the workers would commute to the construction site, thereby reducing the need for rental housing. Based on this information and the analysis of human health and environmental impacts presented in this chapter, the construction of the DTS and replacement of the ISFSI would not have disproportionately high and adverse human health and environmental effects on minority and low-income populations. Similar to the short-term

Environmental Impacts of At-Reactor Continued Storage of Spent Fuel

storage, a small number of workers (30–35) would be needed to maintain and monitor the at-reactor ISFSI after cask transfers to the replacement facility. Consequently, employment opportunities, although reduced from reactor operations, would remain unaffected for minority and low-income populations. Based on this information, there would be no disproportionately high and adverse human health and environmental effects on minority and low-income populations from the construction and operation of the DTS and replacement of the DTS and at-reactor ISFSI.

For long-term spent fuel storage, REMPs, similar to those implemented during nuclear power plant operations and short-term storage, would ensure that the radiation dose from DTS operations and continued spent fuel storage would remain within regulatory limits. Similar to short-term storage, a modified REMP would be in place to confirm that radiological doses remain within regulatory limits and minority and low-income populations would experience no new human health and environmental effects during the long-term timeframe beyond those experienced during reactor operations.

The continued maintenance and monitoring of spent fuel in at-reactor ISFSIs would have minimal human health and environmental effects on minority and low-income populations near these storage facilities. As discussed for the other resource areas in Chapter 4, overall human health and environmental effects from continued storage during the long-term timeframe would be limited in scope and SMALL for all populations, except for historic and cultural resources where impacts could be SMALL to LARGE. Long-term storage impacts on historic and cultural resources are discussed in Section 4.12. The magnitude of adverse effects on historic properties and the impacts on historic and cultural resources during the long-term timeframe largely depend on where the facilities are sited, what resources are present, the extent of proposed land disturbance, if the area has been previously surveyed to identify historic and cultural resources, and if the licensee has management plans and procedures that are protective of historic and cultural resources. Before ground-disturbing activities occur, the site-specific environmental review and compliance with the NHPA process could identify historic properties and historic and cultural resources that could be impacted. Thus, the potential impacts on historic and cultural resources could be SMALL to LARGE. However, measures such as implementation of historic and cultural management resource plans and procedures, agreements, and license conditions can be used to avoid, minimize, or mitigate adverse effects on historic properties and impacts on historic and cultural resources. Based on this information, minority and low-income populations are not expected to experience disproportionately high and adverse human health and environmental effects from the continued long-term storage of spent fuel. In addition, as indicated in the Commission's policy statement (69 FR 52040), environmental justice impacts would also be considered during site-specific environmental reviews for specific licensing actions.

4.3.3 Indefinite Storage

This section describes the environmental impacts on minority and low-income populations if a repository is not available to accept spent fuel. With no repository available, an at-reactor ISFSI would be continuously monitored and maintained. Impacts from indefinite onsite storage would be similar to those described in Section 4.3.2.

The continued maintenance and monitoring of spent fuel would have minimal human health and environmental effects on minority and low-income populations living near at-reactor ISFSIs. As discussed for the other resource areas in Chapter 4, overall human health and environmental effects from continued storage during the indefinite timeframe would be limited in scope and SMALL for all populations, except for nonradioactive waste generation and disposal and historic and cultural resources where impacts could be SMALL to MODERATE or SMALL to LARGE, respectively. The magnitude of adverse effects on historic properties and impacts on historic and cultural resources during the long-term timeframe largely depend on where the facilities are sited, what resources are present, the extent of proposed land disturbance, if the area has been previously surveyed to identify historic and cultural resources, and if the licensee has management plans and procedures that are protective of historic and cultural resources. Before ground-disturbing activities occur, the site-specific environmental review and compliance with the NHPA process could identify historic properties and historic and cultural resources that could be impacted. Regardless, minority and low-income populations are not expected to experience disproportionately high and adverse human health and environmental effects from the indefinite storage of spent fuel. In addition, as indicated in the Commission's policy statement (69 FR 52040), environmental justice impacts would also be considered during site-specific environmental reviews for specific licensing actions.

4.4 Air Quality

This section describes impacts on air quality caused by continued storage in spent fuel pools and at-reactor ISFSIs. Because there would be no increase in emissions during continued storage, the requirements for a conformity determination under 40 CFR Part 93 do not apply to the operation of a spent fuel pool or an at-reactor ISFSI. The requirements for a conformity determination with respect to the replacement of an ISFSI and the construction, operation, and replacement of a DTS are considered in the long-term storage section (see Section 4.4.2).

4.4.1 Short-Term Storage

Once reactor operations cease and continued storage begins, most pollutant-generating activities at the nuclear power plant site would either cease or continue at lower levels. Therefore, as described below, the environmental impacts on air quality during continued storage would be less than the impacts during reactor operations.

Environmental Impacts of At-Reactor Continued Storage of Spent Fuel

The License Renewal GEIS concluded that impacts for continued power-generation operations in attainment, nonattainment, and maintenance areas are SMALL for all plants, at least in part because licensees would be required to operate within State permit requirements (NRC 2013a). Specifically, the License Renewal GEIS analyzes a number of specific activities related to continued power-generation operations that result in emissions of air pollutants. These include testing of emergency diesel generators, use of fossil-fuel boilers (for evaporator heating, plant space heating, and feed water purification), testing of fossil-fuel-fired fire pumps, cooling-tower drift, and transmission-line emissions. When the nuclear power plant ceases operations and the site enters the short-term storage timeframe, many of these activities will also cease. For example, testing requirements may be reduced or eliminated for emergency diesel generators, which are no longer needed to maintain and restore reactor core or spent fuel pool cooling once the reactor is permanently shutdown. Also, cooling towers would no longer be rejecting up to two-thirds of the thermal power of a reactor, which would dramatically reduce cooling-tower drift. Because emissions of air pollutants resulting from continued storage of spent fuel in either spent fuel pools or at-reactor ISFSIs would be substantially smaller than air emissions during power generation, air quality impacts from continued storage would also be minor.

Routine maintenance and monitoring activities at the at-reactor ISFSI would occur during short-term storage. Because dry cask storage systems do not have active systems (e.g., diesel generators), these activities would not involve significant releases of air pollutants.

Thermal releases from the at-reactor ISFSI can cause localized atmospheric heating. Downwind from an at-reactor ISFSI storing 1,600 MTU, it is estimated that ambient temperature changes would not be noticeable (i.e., the temperature would increase no more than 0.05°C [0.09°F]) at 1 km (0.6 mi) from the site (NRC 1984). Temperature changes this small could not be differentiated from temperature changes that naturally occur, such as from passage of the sun throughout the day and passing clouds. Over time, the spent fuel in the casks will cool and less heat will be released resulting in less local atmospheric heating. The heat released by storing dry casks on the surface should be distinguished from the greenhouse gas emissions discussed in Section 4.5 of this GEIS. Heat released from a dry cask is a local phenomenon, whereas greenhouse gases released into the atmosphere potentially contribute to impacts beyond the local environment.

Because emissions of air pollutants resulting from short-term continued storage of spent fuel would be substantially smaller than air emissions during power generation, which was determined to have SMALL impacts in the License Renewal GEIS, the NRC concludes the impacts associated with continued spent fuel storage would be SMALL for all location classifications (i.e., attainment, nonattainment, and maintenance). Further, the impact from heat released to the atmosphere from ISFSIs would be SMALL because the small variations in downwind temperatures caused by heat released from the ISFSI could not be differentiated from natural temperature fluctuations.

4.4.2 Long-Term Storage

As noted in Section 1.8, all the spent fuel would be moved out of the spent fuel pool and into at-reactor dry cask storage by the beginning of this timeframe. Routine maintenance and monitoring activities at the at-reactor ISFSI would continue during long-term storage. Because dry cask storage systems do not have active systems (e.g., diesel generators), these activities would not involve significant releases of air pollutants. As described in Section 1.8.3, the NRC assumes that the ISFSI needs to be replaced and the fuel repackaged during this timeframe. To facilitate the transfer of the spent fuel to new casks, the NRC also assumes that a DTS is constructed and replaced once during the long-term storage timeframe.

The construction and replacement of a DTS would involve onsite fabrication involving heavy equipment (earthmoving, concrete batch plant, cranes, etc.), which would cause emissions of air pollutants. Given the relatively smaller size of the DTS compared to an at-reactor ISFSI, the time, materials, and equipment required to build the DTS would be no more than those used to construct an ISFSI. The NRC previously determined that the environmental impact on air quality from construction of the Diablo Canyon ISFSI, which would hold up to 140 dry storage casks from two reactors on a 2-ha (5-ac) site and would be larger than the reference DTS, would be minimal (NRC 2003). Therefore, the air emissions and impacts on air quality for construction and replacement of the DTS would also be minimal. The DTS relies on electrical power for operations. As a result, there are no routine emissions of air pollutants from the DTS during operations, such as might occur from a boiler or diesel generator. A diesel generator could be used as a source of backup electrical power. Testing and use of a backup diesel generator would be infrequent and would cause emissions no greater than those caused by emergency diesel generators at operating nuclear power plants, which are minor.

Activities associated with ISFSI replacement and DTS operations, including cask repair, bare fuel handling as part of repackaging operations, and cask replacement, are expected to be of relatively short duration and limited extent in any year during long-term continued storage. These activities are likely to involve only a portion of the ISFSI, and in any year would likely involve only a fraction of the air emissions that were associated with initial construction of the at-reactor ISFSI. As a result, there may be temporary increases in levels of suspended particulate matter from construction and replacement activities. In addition, exhaust from vehicles would add to levels of hydrocarbons, carbon monoxide, and nitrogen oxides. However, these emissions of air pollutants are not expected to noticeably affect important attributes of air quality in the region.

Previous NRC NEPA analyses for site-specific licensing actions support this conclusion for attainment, maintenance, and nonattainment areas. For example, the NRC analyzed the impacts of constructing and operating an ISFSI at Humboldt Bay (NRC 2005a), which is located in an attainment area, and determined that the air quality impacts were SMALL. The NRC also analyzed the impacts of constructing and operating additional reactor units at existing nuclear

power plant sites such as Calvert Cliffs Unit 3 (NRC 2011a) and Fermi Unit 3 (NRC 2013b), which are located in nonattainment areas. In both examples, the NRC determined that the air impacts were SMALL, at least in part because licensees would be required to operate within State permit requirements. The level of activities and associated air emissions from long-term storage would not be greater than those for the construction and operation of another reactor unit at an existing power plant site.

Emissions of air pollutants during ISFSI replacement and construction, operation, and replacement of a DTS would be well below *de minimis* levels in 40 CFR Part 93 and the requirements for a conformity determination would not apply. *De minimis* emission levels in 40 CFR Part 93 are provided for each criteria pollutant and for different levels of nonattainment, but not all of these limits are relevant to at-reactor continued storage. No operating nuclear power plants are currently located in extreme, severe, or serious ozone nonattainment areas; in serious PM₁₀ nonattainment areas; or in lead nonattainment areas. Therefore, the applicable *de minimis* annual emission rate for all operating nuclear power plants in nonattainment and maintenance areas is 100 T/yr for all criteria pollutants, except volatile organic compounds for plants within an ozone transport region, for which the *de minimis* level is 50 T/yr (NRC 2013a). The NRC estimated the peak annual emissions for preconstruction and construction of the entire Fermi Unit 3 nuclear power plant to be 123.2 T/yr nitrogen oxide and 53.4 T/yr volatile organic compounds (NRC 2013b), which is only slightly above *de minimis* levels. Because the DTS and ISFSI are only a small fraction of the size of an entire nuclear power plant, the emissions of air pollutants during ISFSI replacement and DTS construction and replacement would be well below *de minimis* levels.

Thermal releases from storing dry casks on the surface would cause some local atmospheric heating. As described previously for short-term storage, this effect is not expected to be noticeable and would decrease during the long-term storage timeframe as decay heat in the ISFSI decreases over time.

Emissions of air pollutants during long-term continued storage of spent fuel would be minimal, and the NRC concludes the impacts would be SMALL for all location classifications (i.e., attainment, nonattainment, and maintenance). The impact from heat released to the atmosphere from ISFSIs would be SMALL because the small variations in downwind temperatures would not be noticeable and would decrease throughout this period as decay heat diminishes.

4.4.3 Indefinite Storage

This section describes the environmental impacts on air quality if a repository never becomes available to accept spent fuel. Indefinite storage would consist of the same activities and result in the same impacts as those for long-term storage (Section 4.4.2), except that they would continue indefinitely into the future. Thermal releases from storing dry casks on the surface would cause some local atmospheric heating, which would continue to decrease as decay heat

from spent fuel diminishes. Therefore, the NRC concludes that the environmental impacts on air quality from indefinite storage due to air emissions and thermal releases would each be SMALL.

4.5 Climate Change

In this section, the NRC evaluates the effect of continued storage on climate change. The NRC's evaluation of the effects of climate change on the intensity and frequency of natural phenomena hazards that may cause spent fuel storage accidents is provided in Section 4.18.

4.5.1 Short-Term Storage

This section describes greenhouse gas emissions related to short-term continued storage of spent fuel. The activities at a nuclear power plant during short-term continued storage involve the emission of greenhouse gases, primarily carbon dioxide (CO₂). The quantities of greenhouse gas emissions are often described in terms of a CO₂ footprint expressed as metric tons of CO₂ equivalent. The NRC's previous estimates of a reference reactor's CO₂ footprint during the decommissioning period include activities in addition to those related to continued storage of spent fuel. However, these estimates provide a reasonable upper bound on the CO₂ footprint for short-term continued storage because the activities that occur as a direct result of continued storage would generate less CO₂ than decommissioning activities.

The NRC estimated the CO₂ footprint for a reference 1,000-MW(e) reactor for a 50-year decommissioning period, assuming the licensee chooses the SAFSTOR decommissioning option (NRC 2013c). The greenhouse gas emissions resulting from the SAFSTOR decommissioning option would include all emissions of greenhouse gases that would be associated with the immediate decommissioning (or DECON) option, and also include the greenhouse gases that would be emitted by vehicles used by the caretaker workforce for the intervening 40-year period of SAFSTOR.² Therefore, greenhouse gas emissions associated with the SAFSTOR option bound those associated with the DECON option. The NRC assumed that SAFSTOR lasts for 40 years and is followed by 10 years of major decommissioning activities. The predominant sources of greenhouse gas emissions during major decommissioning activities are fossil-fuel powered demolition equipment and worker transportation vehicles for the estimated 200 decommissioning workers (NRC 2013c). Continued storage activities at the spent fuel pool and at-reactor ISFSI do not involve significant sources of fossil-fuel consuming activities, other than the use of vehicles by the commuting

² In the third option, the ENTOMB option, radioactive systems, structures, and components are encased in a structurally long-lived substance, such as concrete. The entombed structure is appropriately maintained, and continued surveillance is carried out until the radioactivity decays to a level that permits termination of the license. No licensee has ever chosen the ENTOMB option, and it is not considered further in this GEIS.

workforce, and the occasional use of onsite vehicles for inspection and maintenance of spent fuel storage facilities. Therefore, greenhouse gas emissions from decommissioning activities would be more than the greenhouse gas emissions associated with the smaller workforce responsible for continued storage. The CO₂ footprint of decommissioning is on the order of 37,000 MT of CO₂ equivalent (NRC 2013c), or an annual emission rate of about 740 MT, averaged over the period of decommissioning, compared to a total U.S. annual CO₂ emissions rate of 6.7 billion MT of CO₂ equivalent in 2011 (EPA 2013).

Based on its assessment of the relatively small short-term continued storage greenhouse gas footprint compared to the U.S. annual CO₂ emissions, the NRC concludes that the atmospheric impacts of greenhouse gases from short-term continued storage would not be noticeable and would therefore be SMALL.

4.5.2 Long-Term Storage

This section describes the greenhouse gas production of continued storage during long-term continued storage. Over the long-term storage timeframe, sources of greenhouse gas emissions include vehicles used by the commuting workforce and workers conducting routine maintenance activities for the at-reactor ISFSI and construction and demolition equipment required to initially construct, and eventually replace, a DTS and to replace the at-reactor ISFSI. Given that activities at the site have been reduced to continued storage of spent fuel at the at-reactor ISFSI, the CO₂ footprint for the commuting workforce would be no greater than that associated with the SAFSTOR workforce described previously. Using the greenhouse gas emission rate of 10,000 MT of CO₂ equivalent over 40 years associated with the SAFSTOR option, this is approximately 25,000 MT of CO₂ equivalent over the 100-year long-term storage timeframe (NRC 2013c).

The NRC's estimated CO₂ footprint for a reference 1,000-MW(e) reactor provides a useful upper bound for the CO₂ footprint that would be associated with construction and replacement of the ISFSI and DTS, which are much smaller facilities. The CO₂ footprint for construction equipment used to build a 1,000-MW(e) reactor is about 39,000 MT of CO₂ equivalent. The CO₂ footprint for decommissioning equipment used on a 1,000-MW(e) reactor is about 19,000 MT of CO₂ equivalent (NRC 2013c).

Combining the total CO₂ footprints for the commuting workforce, construction and replacement activities, and averaging over the 100-year long-term storage timeframe, the annual CO₂ footprint is estimated to be no more than 830 MT of CO₂ equivalent, compared to a total U.S. annual CO₂ emissions rate of 6.7 billion MT of CO₂ equivalent in 2011 (EPA 2013). Based on its assessment of the relatively small long-term continued storage greenhouse gas footprint compared to the U.S. annual CO₂ emissions, the NRC concludes that the atmospheric impacts of greenhouse gases from long-term continued storage would not be noticeable and would therefore be SMALL.

4.5.3 Indefinite Storage

This section describes the greenhouse gas production of continued storage if a repository never becomes available to accept spent fuel. The main difference when compared to the impacts during long-term storage is that without a repository these activities would occur on an ongoing basis over a longer period of time so the total amount of emissions would be greater. However, the annual emission levels for the various phases would remain the same.

The NRC concludes that the relative contribution from indefinite onsite storage of spent fuel to greenhouse gas emission levels would be SMALL based on the same considerations as those cited previously in the long-term storage section.

4.6 Geology and Soils

This section describes the potential environmental impacts on geology and soils caused by the continued onsite storage of spent fuel.

4.6.1 Short-Term Storage

Continued spent fuel pool operation is not anticipated to increase impacts on the local geology and soils. However, spent fuel pool leaks could result in radiological contamination of offsite soils. The degree of contamination of offsite soils would depend on the rate of release from the spent fuel pool, the direction of groundwater flow, the distance to offsite locations, and the velocity or transport rates of radionuclides through soils and radioactive decay rates.

Contamination in groundwater is likely to be observed as part of a licensee's REMP prior to the contamination plume reaching the offsite environment, and corrective action would be taken consistent with Federal and State requirements. In addition, most radionuclides are likely to be absorbed by the concrete structures of the spent fuel building and by the soil surrounding the leak location. As a result, the NRC expects that most soil contamination from spent fuel pool leaks would remain onsite and, therefore, offsite soil contamination is unlikely to occur.

Therefore, the NRC concludes that the environmental impact of spent fuel pool leaks to offsite soils (i.e., outside the power plant's exclusion area) would be SMALL. Appendix E contains additional information regarding the analysis of the impacts of spent fuel pool leaks on soils.

Continued ISFSI operation is not expected to affect the underlying geology because ISFSIs have no moving parts to affect the subsurface (see e.g., NRC 2012a). Although soils may be affected by spills and leaks of radiological and hazardous materials, ISFSIs are designed to prevent leakage and licensee employees conduct routine inspections to verify that the ISFSIs are performing as expected. Leaks could result in spills of oil and hazardous material from operating equipment and stormwater runoff carrying grease. However, these activities are monitored and, in the case of stormwater runoff, regulated under National Pollutant Discharge Elimination System (NPDES) permit requirements (NRC 2002b).

Because no new land would be disturbed for the continued operation and maintenance of the existing pool and ISFSI and the impacts from spent fuel leaks to offsite soils would be SMALL, the NRC concludes that the continued storage of spent fuel during short-term storage on geology and soils would be SMALL.

4.6.2 Long-Term Storage

During the long-term storage timeframe, routine maintenance and monitoring of the ISFSI would continue. Similar to short-term storage, the operation of any ISFSI is not anticipated to have any additional impacts on soils beyond those associated with construction.

The construction of a DTS is anticipated to have minimal impacts on soils due to the small size of the DTS, which is about 0.7 ha (2 ac). The types of impacts on soils from construction of a DTS would be similar to those anticipated for any power plant facility construction and would include soil compaction, soil erosion, and potential surface leaks of oils, greases, and other construction materials. Due to the relatively small size of the DTS, the impacts would be limited to the immediate area. Any laydown areas associated with construction would be reclaimed once the construction phase is complete. The GEIS also assumes that the ISFSI and DTS would require replacement and would occur on land near existing facilities. There would be no permanent increase in the overall area of land disturbed because the old facilities would be demolished and the land could be reclaimed.

The construction and operation of the DTS, along with the replacement of the DTS and ISFSI facilities, would have minimal impacts on soils on the small fraction of the land committed for the facilities. There are no anticipated impacts on the geology of the area as the result of these activities. Therefore, the NRC concludes that the environmental impact on geology and soils would be SMALL during long-term storage.

4.6.3 Indefinite Storage

In this section, impacts are evaluated assuming a repository does not become available. As previously noted, the ISFSI would require continued maintenance and monitoring. In addition, the ISFSI, storage casks, and DTS are assumed to be replaced every 100 years using a staged approach. As described above, no additional land would be required for these activities. At the end of the next 100-year cycle it is anticipated that the replacement of the ISFSI and DTS would occur on previously disturbed land, thereby minimizing impacts on soils. Given the temporary nature of the impacts on geology and soils, and the occurrence of the impacts within previously disturbed areas, the NRC concludes that the environmental impacts on geology and soils from the indefinite onsite storage of spent fuel would be SMALL.

4.7 Surface-Water Quality and Use

This section describes potential environmental impacts on the quality and consumptive use of surface water caused by continued storage of spent fuel in spent fuel pools and ISFSIs.

4.7.1 Short-Term Storage

During the short-term timeframe, most environmental impacts on surface-water resources will cease due to the end of reactor operations. For example, consumptive water loss per 1,000 MW(e) for different cooling systems used at operating power plants ranges from 30,700 L/min (8,100 gpm) for plants that use once-through cooling system to 53,000 L/min (14,000 gpm) at plants with mechanical draft cooling towers (NRC 2013a). After permanent cessation of operations, the amount of heat rejected by these cooling systems would drop from over 10,000 BTU/hr to approximately the initial 40-BTU/hr decay heat load associated with cooling a spent fuel pool shortly after fuel is discharged from a reactor (EPRI 2002). Other potential impacts on surface-water resources would result from use of water to shield workers from radiation in the reactor area, continued stormwater management, and minor chemical spills. With more than 99 percent reduction in the amount of heat to be discharged, and a corresponding reduction in cooling-water demand, potential impacts from these activities would be significantly less severe than those associated with normal plant operation. The same activities described above also may affect surface-water quality. Surface waters are most likely to be affected by stormwater runoff, erosion, and by discharge of hazardous substances. However, these activities are monitored and regulated under NPDES permit requirements (NRC 2002b).

4.7.1.1 Spent Fuel Pools

As described above, because cooling-water demand would be significantly reduced after reactor operations have ceased, the NRC has determined that impacts on surface-water consumptive use from the continued storage of spent fuel in spent fuel pools will not be detectable or be so minor that they would not noticeably alter the water supply.

Surface-water quality may be affected by groundwater contamination. The NRC has completed a review of its overall regulatory approach to groundwater protection (NRC 2011b). The NRC started this review in response to incidents of radioactive contamination of groundwater and soils at nuclear power plants. Contaminated groundwater at some sites may discharge to nearby surface waters, resulting in indirect effects on surface-water quality. The concentrations of radionuclides in offsite surface waters would depend on the rate of release from the spent fuel pool, direction and rate of groundwater flow, the distance to nearby offsite surface waters toward which groundwater flows, the velocity or transport rates of radionuclides through the subsurface, and radioactive decay rates. However, because surface waters in the vicinity of nuclear power plants are usually large to meet reactor cooling requirements, a large volume of

surface water is usually available to dilute groundwater contaminants that flow into the surface waterbody. This dilution results in contaminants that may have been present above applicable groundwater-quality standards being diluted well below limits considered safe.

The NRC, in Appendix E, estimated an annual discharge rate for leakage from the spent fuel pool of 380 L/d (100 gpd) with contaminants at certain concentrations assumed to be present at the start of short-term storage. These concentrations were compared to annual effluent ranges for BWRs and PWRs. Even in the unlikely event that spent fuel pool leakage flowed continuously (24 hours per day, 365 days per year) undetected to local surface waters, the quantities of radioactive material discharged to nearby surface waters would be comparable to values associated with permitted, treated effluent discharges from operating nuclear power plants (see Table E-2). Based on the above considerations, the NRC concludes that the impact of spent fuel pool leaks on surface water would be SMALL. More information about the NRC's analysis of the environmental surface-water-quality impacts of continued storage of spent fuel on nearby surface waters from groundwater contamination can be found in Appendix E of this GEIS.

4.7.1.2 ISFSIs

As passive, air-cooled storage systems, ISFSIs do not consume water and they generate minimal liquid effluents that may be discharged to surface waterbodies during normal operation. For example, in its consideration of water-use impacts for the renewal of the Calvert Cliffs ISFSI, the NRC determined that both direct and indirect impacts would be SMALL (NRC 2012a). This includes consideration of cask-loading operations and stormwater runoff carrying grease, oil, and spills from operating equipment that support the ISFSI.

4.7.1.3 Conclusion

Because short-term storage of spent fuel would use less surface water and have fewer activities that could affect surface-water quality than an operating reactor, which was previously determined to have a SMALL impact, and because leaks from spent fuel pools would have a SMALL impact on surface-water quality, the NRC concludes that impacts on surface-water quality and consumptive use during the short-term storage timeframe would each be SMALL.

4.7.2 Long-Term Storage

During long-term storage, there is no demand for surface water for routine maintenance and monitoring of an at-reactor ISFSI. In addition, as during short-term continued storage described above, water-quality impacts from ISFSI operations would be minimal. However, during long-term continued storage, there could be temporary consumptive use of surface water for demolishing and replacing the ISFSI and constructing and eventually replacing a DTS.

Environmental Impacts of At-Reactor Continued Storage of Spent Fuel

During ISFSI demolition, a small amount of water could be sprayed from water trucks to minimize dust clouds. Additional water may be required to make concrete to replace facilities. For example, it would require about 380,000 L (100,000 gal) of water to make the concrete to replace an entire 46 × 46 m (150 × 150 ft) ISFSI pad that is 1 m (3 ft) thick. A comparable amount could be required to replace dry cask storage system components, such as storage casks. If the activity were to take several months to complete, the average daily consumptive water use would be a few thousand gallons, which is less than the consumptive water loss estimated for an operating reactor for 1 minute (NRC 2013a). Therefore, the consumptive water-use impacts for demolishing and replacing the ISFSI would be minimal.

The NRC assumes that a DTS would need to be constructed and replaced during the long-term storage timeframe. The construction and operation of a DTS involves very little temporary consumptive use of water. While some water would be required for construction of the DTS concrete basemat and shell, it is expected that ready-mix concrete would be used and supplied by commercial vendors. Given the relatively small size of the DTS compared to an ISFSI, less water would be required to build the DTS than would be used to construct the ISFSI. During operations, water would be brought to the facility by tanker truck or temporary connection to public water supply for general purpose cleaning and canister decontamination. Additional water might be consumed by activities such as drinking, conducting personal hygiene, and disposing of sewage.

The NRC concludes that the potential consumptive use and surface-water quality impacts from continued ISFSI operations would be minimal. Consumptive use of surface water for ISFSI replacement and DTS construction, operation, and replacement would involve amounts of water that are a small fraction of water use during reactor operations. Therefore, the NRC concludes that the potential impacts on surface-water use and quality for the long-term storage timeframe would be SMALL.

4.7.3 Indefinite Storage

If no repository becomes available, storage of spent fuel would continue indefinitely. As a result, the potential impacts on surface-water resources would be similar to those described for long-term storage (see Section 4.7.2) because the same activities would recur. Every 100 years, surface water would be required for demolishing and replacing the ISFSI and DTS. This additional consumptive use would be temporary. Therefore, the NRC concludes that the potential impacts on surface-water use and quality for the indefinite storage of spent fuel would each be SMALL.

4.8 Groundwater Quality and Use

This section describes the potential environmental impacts on groundwater water quality and consumptive use caused by continued storage of spent fuel in spent fuel pools and at-reactor ISFSIs.

4.8.1 Short-Term Storage

During short-term storage, most groundwater consumptive-use and quality impacts that had been caused by reactor operations would cease. Groundwater withdrawals may continue at some reactor sites during short-term storage because groundwater may be pumped for potable water, sanitary uses, and maintenance of spent fuel pools. This usage would likely be at a much reduced rate compared to normal reactor operations at the site. At other sites, offsite public water sources or onsite groundwater could also be used. This shift in usage would likely coincide with the reduction and eventual elimination of surface-water withdrawals, when they are no longer needed to support reactor cooling. However, surface-water resources may be used for some activities at some sites. Dewatering systems (e.g., foundation sumps, underdrains, and wells) to control high water tables, seepage of water into the subgrade of structures, or for hydraulic containment of contaminants may also remain active during decommissioning.

The NRC determined in the License Renewal GEIS that consumptive use of groundwater during reactor operation would be SMALL because groundwater supplies are commonly not used or are used as a backup water source. During normal reactor operations, at most reactors, the withdrawal rate from production aquifers is kept below 380 L/min (100 gpm) to avoid groundwater-use conflicts (NRC 2013a). When reactor operations cease, the use of groundwater is greatly reduced, especially at sites where reactor operations use groundwater as a backup water source (e.g., H.B. Robinson Steam Electric Plant [NRC 2005b]), because cooling-water system demands are substantially lower after the facility is shut down and spent fuel is removed from the reactor vessel (NRC 2002b).

4.8.1.1 Spent Fuel Pools

Because consumptive water-use impacts on groundwater resources during short-term storage of spent fuel in spent fuel pools would be significantly less than during normal reactor operation, the resultant impacts on groundwater at offsite wells would be nondetectable or so minor that they would not noticeably alter groundwater resources. As a result, the NRC has made a generic conclusion that the consumptive water-use impacts on groundwater resources during short-term storage of spent fuel in spent fuel pools would be minor or minimal.

Continued short-term storage of spent fuel in spent fuel pools could result in radiological impacts on groundwater quality. As discussed in Appendix E, in the unlikely event that a leak

Environmental Impacts of At-Reactor Continued Storage of Spent Fuel

from a spent fuel pool goes undetected and the resulting groundwater plume reaches the offsite environment, it is possible that the leak could be of sufficient magnitude and duration to contaminate a groundwater source above a regulatory limit (e.g., a maximum contaminant level for one or more radionuclides). The NRC acknowledges that should offsite groundwater contamination occur, the radiological impacts on groundwater quality resulting from a spent fuel pool leak during the short-term timeframe could noticeably alter, but not destabilize a groundwater resource.

However, the impacts of a spent fuel pool leak on offsite groundwater receptors depend on many factors, including the volume and rate of water released from the spent fuel pool, the radionuclide content and concentration and water chemistry of the spent fuel pool water, the direction of groundwater flow, the distance to an offsite groundwater receptor, the velocity or transport rates of radionuclides through the subsurface, and radioactive decay rates. Further, as discussed in Appendix E, spent fuel pool design (e.g., stainless-steel liners and leakage-collection systems) and operational controls (e.g., monitoring and surveillance of spent fuel pool water levels) make it unlikely that a leak will remain undetected long enough to exceed any regulatory requirement (e.g., the NRC dose limit or U.S. Environmental Protection Agency [EPA]-mandated Maximum Contaminant Level) in the offsite environment. Although a small number of spent fuel pool leaks have caused radioactive liquid releases to the environment, based on the available data, none of these releases have affected the health of the public (NRC 2006a). In addition, licensees have implemented onsite groundwater monitoring programs that satisfy the requirements of 10 CFR 20.1501. Performing onsite groundwater monitoring throughout the short-term storage timeframe, in conjunction with other onsite and offsite radiological monitoring conducted as part of a licensee's REMP, will allow licensees to detect radiological contamination in the event of a spent fuel pool leak, and should facilitate detection of a leak in sufficient time to prevent the offsite migration of contamination at levels that could exceed regulatory requirements (e.g., the NRC dose limit or EPA-mandated Maximum Contaminant Level). In addition, a variety of physical processes associated with radionuclide transport (see Section E.2.1.2) and hydrologic characteristics associated with typical nuclear power plant settings (see Section E.2.1.3) would act to mitigate the impacts from the offsite migration of future spent fuel pool leakage. These physical processes and hydrologic characteristics include radionuclide adsorption, dilution, and decay; delayed transport times due to relatively flat hydraulic gradients in the shallow water tables, lengthy distance to local groundwater users, and the likelihood that local groundwater usage is in deeper confined aquifers, respectively. Further, current and future spent fuel pool sites are required to have routine REMPs in place that should take samples at offsite groundwater sources (e.g., potable or irrigation) in areas where the hydraulic gradient or recharge properties are suitable for contamination (NRC 1991a,b). Finally, any detection of onsite contamination would likely result in additional monitoring, including additional sampling of any nearby private wells, as part of an expanded environmental monitoring program. With these measures and characteristics in place, it is unlikely that offsite migration of spent fuel pool leaks will occur or go undetected.

Environmental Impacts of At-Reactor Continued Storage of Spent Fuel

Based on these factors, the NRC concludes that the radiological impacts on groundwater quality resulting from a spent fuel pool leak during the short-term timeframe would be SMALL.

The NRC is aware that unintentional releases of nonradiological hazardous substances have infrequently occurred after reactors shut down. Except for a few substances (e.g., diesel fuel), surface spills of hazardous substances that might lead to groundwater contamination are often localized, quickly detected, and relatively easy to remediate (NRC 2002b). During the short-term timeframe, the licensee will decommission the site, which will result in the ultimate cleanup of the portions of the reactor facility that are not needed for continued short-term storage in a spent fuel pool. In addition, permit requirements (e.g., NPDES permit) and the requirements for compliance with the Resource Conservation and Recovery Act (RCRA) and the Safe Drinking Water Act would minimize potential risks for nonradiological contamination entering groundwater during short-term spent fuel storage in spent fuel pools.

Therefore, the NRC concludes that during short-term storage, the nonradiological impacts on groundwater quality would be minimal.

4.8.1.2 ISFSIs

ISFSIs, which are passive systems, consume minimal water and generate minimal nonradiological liquid effluents during normal operation (see e.g., NRC 2012a). The only potential impact on groundwater quality from operating an ISFSI consists of the infiltration of stormwater runoff carrying grease and oil, and spills from operating equipment that supports the ISFSI. Because ISFSI storage requires minimal water and produces minimal, localized, and easy-to-remediate liquid effluents on or near the ground surface, ISFSI storage impacts on groundwater quality and use would not be detectable or would be so minor that they would not noticeably alter groundwater resources. As a result, the NRC concludes that the potential consumptive water-use and quality impacts on groundwater during ISFSI storage of nuclear fuels would be minimal.

4.8.1.3 Conclusion

Based on the discussion above, the NRC concludes that consumptive water-use impacts on groundwater resources during short-term storage of spent fuel in spent fuel pools and at-reactor ISFSIs would be SMALL. For groundwater quality, the NRC concludes that radiological and nonradiological impacts during the short-term storage of spent fuel in pools and ISFSIs would be SMALL.

4.8.2 Long-Term Storage

The consumptive water use associated with routine maintenance and monitoring of the ISFSI discussed for short-term storage would continue during long-term storage. In addition, the NRC

assumes that a DTS would need to be constructed and operated during long-term storage. The construction and operation of a DTS involves very little consumptive use of groundwater. Concrete used for construction of the basemat and shell would likely arrive ready mixed and would not require additional water. For example, the NRC previously identified that little or no water would be consumed by the construction of the Calvert Cliffs and Prairie Island ISFSIs (NRC 1991c, 1992). Because the size of the DTS would be small compared to an ISFSI, less water would be required to construct the DTS than would be used to construct the ISFSI. During DTS operations, water would be brought to the facility by tanker truck or temporary connection to public water supply for general purpose cleaning and canister decontamination. Additional water might be consumed by activities such as drinking, conducting personal hygiene, and disposing of sewage.

The impacts on groundwater quality from the operation of the ISFSI during long-term storage would be similar to the impacts discussed previously for short-term storage (Section 4.1.1). While operation of the DTS does consume water, no groundwater quality affecting discharges are expected. Therefore, the consumptive groundwater-use and quality impacts from construction of the DTS and operation of the ISFSI, including the DTS would be minimal during long-term storage.

With regard to ISFSI and DTS replacement activities, the consumptive-use and groundwater-quality impacts would be similar to those associated with initial construction of the ISFSI. For example, the NRC staff determined that construction of the Calvert Cliffs and Prairie Island ISFSIs (NRC 1991c, 1992) would have negligible to no impacts on water resources. Similarly, the groundwater-quality and consumptive-use impacts associated with ISFSI and DTS replacement activities during long-term storage would be minor.

Because the potential impacts on groundwater water quality and consumptive water uses during long-term storage would be similar to the impacts during short-term dry storage, the NRC concludes that the impacts on groundwater quality and consumptive use associated with the long-term storage of spent fuel in an at-reactor ISFSI would be SMALL.

4.8.3 Indefinite Storage

If no repository becomes available, storage of spent fuel in an ISFSI would continue indefinitely. As a result, the potential impacts on groundwater resources would be similar to those described for long-term storage (Section 4.8.2) because the same activities would be happening at the storage site. Every 100 years, groundwater may be required for demolishing and replacing the ISFSI and DTS. This additional consumptive use would be temporary. Therefore, the NRC concludes that the potential impacts on groundwater use and quality if a repository is not available would each be SMALL.

4.9 Terrestrial Resources

This section describes potential environmental impacts on terrestrial resources caused by the continued storage of spent fuel in spent fuel pools and at-reactor ISFSIs.

As explained in Section 3.8, a wide variety of terrestrial habitats are present at nuclear power plant sites, which include spent fuel pools and at-reactor ISFSIs. The generic environmental impact analyses in this section consider both existing generic analyses and site-specific analyses that the NRC completed for licensing and relicensing of nuclear power plants and ISFSIs. The significance of potential impacts on plants and animals and their habitats depends on the importance or role of the plant or animal within the ecological community that is affected.

4.9.1 Short-Term Storage

During the short-term storage timeframe, many activities that occurred during the operation of the reactor that could affect terrestrial resources would cease. However, terrestrial resources will likely continue to be affected during this timeframe by the continued operation of the spent fuel pool cooling system, and by the operation and maintenance of systems and structures at the nuclear power plant site and the at-reactor ISFSI.

4.9.1.1 Spent Fuel Pools

The following discussion describes the impacts of spent fuel pool operations during short-term storage, using the impact analyses from the License Renewal GEIS to inform the NRC's analysis of these impacts during short-term storage. Operation of a spent fuel pool and its associated cooling system during short-term storage would require the withdrawal of water and discharge of effluents into a nearby waterbody. The NRC evaluated the effects of the continued operation of nuclear power plants, which included the operation of associated spent fuel pools, on terrestrial resources in the License Renewal GEIS (NRC 2013a). The NRC then looked at the systems that would be needed to cool the spent fuel pool during short-term storage, and compared the impacts associated with water use during operations and water use after the end of operations.

Water-Use Conflicts with Terrestrial Resources at Plants with Cooling Ponds or Cooling Towers Using Makeup Water from a River

Water from nearby lakes, rivers, and oceans is needed for both closed and once-through cooling systems. Water-use conflicts with terrestrial resources could occur if water from a single waterbody is required to simultaneously cool a spent fuel pool and support other water users such as agricultural, municipal, or industrial users. A conflict could arise if the surface-water resource is diminished because of decreased water availability due to low flow or drought conditions; increased demand for agricultural, municipal, or industrial usage; or a combination of factors (NRC 2013a).

Environmental Impacts of At-Reactor Continued Storage of Spent Fuel

The License Renewal GEIS evaluated the potential impacts on terrestrial biota and concluded that the impacts from water-use conflicts with terrestrial resources could, in certain situations, result in noticeable impacts on terrestrial resources (NRC 2013a). For example, Wolf Creek Generating Station in Kansas, which operates a cooling pond to cool plant systems, withdraws makeup water for the pond from the Neosho River located downstream of the John Redmond reservoir. The riparian communities downstream of the reservoir may be temporarily affected by the plant's water use during periods when the reservoir level is low and makeup water is obtained from the Neosho River (NRC 2013a). Water-use conflicts during reactor operations, such as those described previously, could result in SMALL to MODERATE impacts due to the uncertainty associated with water availability to a plant for future water use (see, e.g., NRC 2008a).

However, the water-withdrawal requirements for a spent fuel pool are considerably lower than those for a power reactor (see Table 4-1 and Section 4.7.1). The NRC staff assumes that a licensee would continue to withdraw surface water for the nuclear power plant's service-water system to provide cooling makeup water for the spent fuel pools during short-term storage. As noted in Section 4.8.1, a licensee could also use groundwater or a combination of surface water and groundwater given the reduced cooling demands of the spent fuel pool over time. Water withdrawals would continue to be subject to applicable water appropriation or allocation permit requirements, as well as Clean Water Act Section 316(b) requirements for minimizing adverse environmental impacts associated with the use of cooling-water-intake structures, as may be prescribed in NPDES permits. As part of the permit review, the responsible State, or governing water-basin commission where applicable, would assess the local water availability to help prevent water-use conflicts.

Table 4-1. Reference Plant Withdrawal Rates and Heat Loads

	Reactor		Spent Fuel Pool
	Once-Through Cooling	Closed-Cycle Cooling	
Withdrawal Rate (gpm) ^(a)	800,000 ^(b)	12,000 ^(c)	2,800 ^(d)
Heat Load (10 ⁶ BTU/hr)	10,000 ^(b)	10,000 ^(b)	35 ^(b,e)

(a) The exact amount of water withdrawn depends on a variety of conditions, including water temperature, cooling system, size of the nuclear plant, and operational conditions.

(b) Approximate values based on a typical 1,000-MW(e) nuclear power plant.

(c) EPRI 2002.

(d) Value calculated based on a ratio of once-through cooling flow and heat load for a reactor, compared to design heat load for a spent fuel pool. Actual flow would vary based on site-specific characteristics, such as age and amount of spent fuel in the pool, surface-water temperature, etc. Value represents the maximum rate of water withdrawal expected during the timeframe analyzed in this GEIS, and would decrease as time after shutdown increases.

(e) Design heat load for a spent fuel pool.

Regardless of the makeup source, return service water, including heat removed from the fuel pool, would be discharged to the surface waterbody in an open cycle, as further discussed in Section 4.10.1.1. A delegated State agency or the EPA would also require the licensee to continue to operate under a modified or new NPDES permit, which would limit the chemical quality and temperature characteristics of the facility's surface water discharge so that no water-quality impairment or use conflict occurs. In addition, the State agency or the EPA would review and, if necessary, update the NPDES permit every 5 years. Therefore, the NRC concludes that water-use conflicts during short-term storage would have minimal impacts on terrestrial resources.

Other Potential Impacts from the Spent Fuel Pool Cooling System

The License Renewal GEIS determined that all other potential impacts on terrestrial ecology from the operation of the cooling system would be SMALL at all nuclear power plant sites. These additional impacts include the following:

- exposure of terrestrial organisms to radionuclides,
- cooling-system impacts on terrestrial resources (plants with once-through cooling systems or cooling ponds), and
- cooling-tower impacts on vegetation.

The License Renewal GEIS determined that these impacts on terrestrial ecology would be SMALL at all power plants based on review of literature, operational monitoring reports, consultations with utilities and regulatory agencies, and license renewal supplemental EISs (SEISs) published to date. The License Renewal GEIS indicated that exceptions have been observed at some nuclear plants; however, licensees have addressed the impacts by changing plant operations to prevent impacts.

For example, the License Renewal GEIS reviewed scientific literature on the effects of radiological doses to biota, and compared those results with the dose rates that have been estimated for terrestrial biota at several nuclear power plants, including plants with spent fuel pools. Based on this assessment, the NRC staff determined that exposure of terrestrial organisms to radionuclides near nuclear power plants was sufficiently less than the U.S. Department of Energy (DOE) and the International Atomic Energy Agency (IAEA) guidelines for radiation dose rates from environmental sources. Further, the levels of plant effluents are limited by radiation standards for human exposure, and those limitations are generally considered to be sufficiently protective of biota other than human. Given that the License Renewal GEIS and site-specific analyses included potential impacts from both operating reactors and spent fuel pools, and that the frequency and quantity of radionuclides released will decrease after reactor shutdown, previous EISs for power reactors contain impact determinations that bound the effects of continued storage on terrestrial resources.

Environmental Impacts of At-Reactor Continued Storage of Spent Fuel

Similarly, during the short-term timeframe, because reactor operations have ceased, the other impacts described above will be less than during operations. Also, because the cooling system requirements for the spent fuel pool (e.g., intake and discharge water volume and heat load rejected) are much less than for an operating reactor, the impacts of the operation of the cooling system will be much less than those considered in the License Renewal GEIS. Therefore, the NRC has determined that the impacts of the spent fuel pool cooling system on terrestrial ecology will be minimal during short-term storage.

Impacts from the Operation and Maintenance of Systems and Structures at the Nuclear Power Plant Site

The License Renewal GEIS evaluated other potential impacts on terrestrial resources from sources other than the operation of the spent fuel pool cooling system. These additional impacts include the following:

- electromagnetic fields on flora and fauna,
- bird collisions with plant structures and transmission lines, and
- transmission-line right-of-way management impacts on terrestrial resources.

The NRC determined in the License Renewal GEIS that these impacts on terrestrial ecology would be SMALL. During the short-term timeframe, electrical power will still be required to operate the spent fuel pool cooling system and to provide power to the system associated with the operation of ISFSIs (e.g., lighting). Licensees may choose to power these systems by maintaining the existing transmission-line infrastructure or replacing this infrastructure with a smaller capacity distribution system. This new distribution system would have smaller impacts than the existing transmission lines because of the smaller profile, reduced electromagnetic field, and reduced vegetative maintenance required around the distribution lines. In addition, fewer structures will be required to be maintained during the short-term timeframe, which would reduce the likelihood of bird collisions with nuclear power plant structures. As a result, the NRC has determined that the impacts from the operation and maintenance of systems and structures at the nuclear power plant site on terrestrial ecology will be minimal during short-term storage.

4.9.1.2 ISFSIs

Normal operation of an ISFSI does not require water for cooling and the facility would produce minimal gaseous or liquid effluents. Therefore, no water withdrawal and minimal discharges would be associated with the operation of ISFSIs. Some radiological exposure and maintenance activities would occur during operation. Maintenance may include some ground-disturbing or rights-of-way management activities. However, impacts on terrestrial resources from short-term storage, including routine maintenance activities, would be temporary.

Environmental Impacts of At-Reactor Continued Storage of Spent Fuel

After they are constructed, at-reactor ISFSIs have similar impacts on terrestrial resources, regardless of their location, due to the passive nature and small size of an at-reactor ISFSI and because minimal liquid or gaseous effluents are generated during normal operations. This is supported by a number of site-specific EAs performed in support of licensing actions that have looked at the environmental impacts on terrestrial resources during ISFSI operations. For example, a number of these reviews found that the ISFSIs would not contribute any significant impacts on terrestrial resources during normal operations (see, e.g., NRC 2012a, 2005a, 2003). Normal operation of an ISFSI would not generate any significant noise, would not significantly affect the area available for terrestrial wildlife, and would not adversely affect terrestrial environments or their associated plant and animal species (see, e.g., NRC 2012a, 2005a, 2003). In addition, while the air temperature in the immediate vicinity of the casks will be higher than ambient temperature, the affected area is limited by the distance from the casks to receptors and is not expected to affect terrestrial resources (see, e.g., NRC 2009a). To the extent that animals and birds are affected by ISFSI operations, they would likely either accustom themselves to regular operations or would relocate away from the facility (see, e.g., NRC 2012a). Further, licensees are required to adhere to the protection of eagles and migratory birds under the Federal Bald and Golden Eagle Protection Act and Migratory Bird Treaty Act. In addition, coordination with State natural resource agencies may further ensure that power plant operators take appropriate steps to avoid or mitigate impacts on State species of special concern that may not be protected under other Federal statutes.

4.9.1.3 Conclusion

Impacts associated with the operation of spent fuel pools and at-reactor ISFSIs would be bounded by the impacts analyzed in the License Renewal GEIS and example ISFSI EAs previously discussed. For operation of the spent fuel pool cooling system, impacts would be bounded by those discussed in the License Renewal GEIS, primarily due to the reduced cooling system requirements for the spent fuel pool (e.g., intake and discharge water volume and heat load rejected). For ISFSI operations, impacts would be similar to those described in example ISFSI EAs because of the passive nature and small size of ISFSIs, and because minimal liquid or gaseous effluents are generated during normal operations. Therefore, the NRC concludes that impacts on terrestrial resources from the operation of spent fuel pools and ISFSIs during the short-term storage timeframe would be SMALL.

4.9.2 Long-Term Storage

During the long-term timeframe, routine maintenance and monitoring of the ISFSIs continues, and the NRC assumes that a DTS is constructed and replaced, the fuel is moved from existing dry storage casks to new dry storage casks, and a new ISFSI is constructed.

Impacts from the ongoing maintenance and monitoring of ISFSIs on terrestrial resources during long-term storage would be similar to the impacts on terrestrial resources from short-term

Environmental Impacts of At-Reactor Continued Storage of Spent Fuel

storage, described in Section 4.9.1. These impacts would be minimal due to the small size of the ISFSIs, because water is not used for cooling, and because minimal liquid or gaseous effluents are generated during normal operations.

ISFSIs are designed as passive systems that require no new or additional long-term maintenance; however, an at-reactor ISFSI is assumed, for this GEIS, to require replacement within the long-term storage timeframe, which would require repackaging of spent fuel at a DTS. Replacement of the ISFSI would occur within the plant's operational area near existing facilities. The older ISFSI would be demolished and the land reclaimed and maintained for the next 100 years.

Impacts on terrestrial resources from ISFSI replacement activities would be similar to those impacts evaluated for the decommissioning of an existing at-reactor ISFSI and the construction of a new at-reactor ISFSI.

During the removal of an existing at-reactor ISFSI, increases in noise levels and changes in localized air quality as a result of fugitive dust and equipment exhaust emissions would likely result in animals and birds temporarily avoiding the activity area. Expected ground-disturbing, re-grading, and reseeded activities associated with removal of the ISFSI are not expected to substantially affect local vegetation. Unless the reclaimed area will be used for another purpose, wildlife would likely re-inhabit the area as vegetation begins to reestablish itself (see, e.g., NRC 2012a).

The impacts of the replacement and management of an ISFSI would be minimal because the construction footprint of an ISFSI is relatively small, the ISFSI would be sited in a previously disturbed area, and the licensees would likely be required to implement best management practices as part of their NPDES permits to address issues such as stormwater runoff. This is supported by a number of site-specific EAs performed in support of licensing actions that have looked at the environmental impacts of the construction of an ISFSI on terrestrial resources. For example, the NRC concluded in the EA for the Calvert Cliffs ISFSI renewal that the impact on ecological resources from decommissioning would be SMALL and would not be significant in part because the 2.4-ha (6-ac) ISFSI area was previously disturbed by ISFSI construction (NRC 2012a). Also, the NRC did not identify any significant impacts on terrestrial resources from construction of the Humboldt Bay ISFSI in part due to the fact that ground-disturbing activities would be limited to 0.4 ha (1 ac) and the ISFSI would not be located near any terrestrial features (NRC 2005a). Similarly, the construction footprint for the Diablo Canyon ISFSI was limited to 2.0 ha (5 ac) and was sited in a previously disturbed area (NRC 2003). In addition, the NRC indicated that controls would be in place to minimize any site runoff, spillage, and leaks (NRC 2003, 2005a). Stormwater control measures, which would be required to comply with NPDES permitting, would also minimize the impacts of site runoff, spillage, and leaks on nearby wetlands.

Like an ISFSI, a DTS would be located within the operational area near existing facilities and, like ISFSI replacement and maintenance activities, a DTS would require construction, replacement, and maintenance activities. Impacts on terrestrial resources from repackaging, operation, and replacement of the DTS would be limited. Like ISFSIs, a DTS could likely be sited on previously disturbed ground or away from sensitive terrestrial features because of the relatively small construction footprint for a DTS (about 0.7 ha [2 ac]) compared to the entire power plant site and because there is a sufficient amount of previously disturbed area on most nuclear power plant sites. The NRC assumes that construction and eventual replacement of a DTS would be temporary (1 to 2 years) and would require a small fraction of the land (about 0.7 ha [2 ac]) committed for a nuclear power plant. The construction laydown area would be reclaimed and revegetated after construction or replacement is completed. There may be temporary increases in traffic, soil erosion, noise, fugitive dust, and habitat reduction from construction, replacement, and refurbishment activities that could affect terrestrial resources. The plant operator could implement best management practices to minimize land disturbances, vegetation removal, erosion, noise, and dust. DTSs and ISFSIs do not require water for cooling. Minimal liquid or gaseous effluents are generated during normal operation. Thus construction, repackaging, and replacement activities for ISFSIs and DTSs would have minimal impacts on terrestrial resources for reasons previously explained. In addition, the NRC expects that normal operations of DTSs and ISFSIs would not generate any significant noise, would not significantly affect the area available for terrestrial wildlife, and would not adversely affect terrestrial environments or their associated plant and animal species. Therefore, the NRC concludes that impacts on terrestrial resources during the long-term storage timeframe would be SMALL.

4.9.3 Indefinite Storage

During indefinite storage, the activities that occur during long-term storage would continue and the ISFSI and DTS would be replaced every 100 years. The NRC concluded in Section 4.9.2 that impacts on terrestrial resources during long-term storage would be SMALL because continued operations, repackaging, DTS construction, and DTS and ISFSI replacement would not adversely affect terrestrial environments or their associated plant and animal species. In addition, replacement of the ISFSI and DTS would likely occur on land near existing facilities and could be sited on previously disturbed ground away from terrestrial species and habitats. By alternating the ISFSI between two onsite locations, the NRC expects the upper limit of land disturbances to be bounded by doubling the land area developed for existing ISFSIs presented in Table 3-1. The older ISFSIs and DTSs would be demolished and the land likely reclaimed. Therefore, the NRC concludes that the impacts on terrestrial resources from indefinite storage of spent fuel at at-reactor ISFSIs would be SMALL.

4.10 Aquatic Ecology

This section describes potential aquatic ecology impacts caused by the continued storage of spent fuel in spent fuel pools and at-reactor ISFSIs. Impacts on aquatic resources include impingement and entrainment; thermal impacts; effects of cooling-water discharge on dissolved oxygen, gas supersaturation, and eutrophication (the over-enrichment of water by nutrients such as nitrogen phosphorus); effects of nonradiological contaminants on aquatic organisms; exposure of aquatic organisms to radionuclides; water-use conflicts with aquatic organisms; and losses from predation, parasitism, and disease among organisms exposed to sublethal stresses.

4.10.1 Short-Term Storage

During the short-term storage timeframe, many activities that occurred during the operation of the reactor that could affect aquatic resources would cease. However, aquatic resources will likely continue to be affected during this timeframe by the continued operation of the spent fuel pool cooling system and the at-reactor ISFSI.

4.10.1.1 Spent Fuel Pools

The following discussion describes the impacts of spent fuel pools during short-term storage, using the impact determinations from the License Renewal GEIS to inform the NRC's analysis of these impacts during short-term storage.

Operation of a spent fuel pool and its associated cooling system during the short-term storage timeframe would require the withdrawal of water and discharge of effluents into a nearby waterbody. To make this comparison, the NRC evaluated the effects of the continued operation of nuclear power plants, which included the operation of associated spent fuel pools, on aquatic ecology in the License Renewal GEIS (NRC 2013a). The NRC then looked at the systems that would be needed to cool the spent fuel pool during short-term storage, and compared the impacts associated with water use during operations to the impacts associated with water use after the end of operations.

Impingement and Entrainment of Aquatic Organisms

Aquatic organisms can be impinged or entrained when cooling-water intakes for spent fuel pools withdraw water that provides habitat to fish, shellfish, plankton, or other aquatic resources. Impingement, which mostly involves fish and shellfish, occurs when organisms are held against the intake screen or netting placed within intake canals. Exhaustion, starvation, asphyxiation, descaling, and physical stresses may kill or injure impinged organisms. The License Renewal GEIS describes some of the fish species commonly impinged at operating power plants as well as other vertebrate species that may also be impinged on the traveling screens or on intake

netting placed within intake canals (NRC 2013a). These species would likely continue to be impinged as a result of operation of the spent fuel pool cooling system during the short-term storage timeframe.

Entrainment occurs when organisms pass through the intake screens and travel through the spent fuel pool condenser cooling system. Heat, physical stress, or chemicals used to clean the cooling system

may kill or injure the entrained organisms. Due to these physical stresses, the NRC assumes 100 percent mortality for all entrained organisms. Typically entrained aquatic organisms include ichthyoplankton (fish eggs and larvae), larval stages of shellfish and other macroinvertebrates, zooplankton, and phytoplankton. Juveniles and adults of some species may also be entrained if they are small enough to pass through the intake screen openings, which are commonly 1 cm (0.4 in) at the widest point. The License Renewal GEIS describes some of the fish species commonly entrained at operating power plants (NRC 2013a). These species would likely continue to be entrained as a result of operation of the spent fuel pool cooling system during the short-term storage timeframe.

Impingement

Impingement is the entrapment of all life stages of fish and shellfish on the outer part of an intake structure or against a screening device during periods of water withdrawal (40 CFR 125.83).

Entrainment

Entrainment is incorporation of all life stages of fish and shellfish with intake water flow entering and passing through a cooling-water-intake structure and into a cooling-water system (40 CFR 125.83).

The severity of impacts associated with impingement and entrainment is dependent upon several factors including the amount of water withdrawn relative to the size of the cooling-water source, location and configuration of intake structures, type of waterbody from which water is withdrawn, conditions within that waterbody, proximity of withdrawal structures to sensitive biological habitats (e.g., spawning and nursery habitats), sensitivity of populations of impinged and entrained organisms to potential losses of individuals, and mitigation measures in place to reduce impingement and entrainment (NRC 2013a). Among these factors, the volume of water withdrawn relative to the size of the water source can be a good predictor of the number of organisms that would be impinged or entrained within a given aquatic system (EPA 2002). Impingement monitoring at the Palisades Nuclear Plant in Michigan demonstrates this difference: In 1972, when the plant used once-through cooling with a water-withdrawal rate of 1,500,000 L/min (400,000 gpm), 654,000 fish were impinged yearly. In 1976, cooling towers were added to the plant, and it began operating as a closed-cycle plant. The intake withdrawal rate was reduced to 295,000 L/min (78,000 gpm), and impingement dropped to 7,200 fish per year (Consumers Energy Company and Nuclear Management Company 2001). These results showed that an approximate 80 percent decrease in water withdrawal resulted in an approximate 98 percent decrease in impingement at Palisades Nuclear Plant.

Environmental Impacts of At-Reactor Continued Storage of Spent Fuel

The License Renewal GEIS concluded that the impacts from impingement and entrainment would be SMALL, MODERATE, or LARGE at operating plants with once-through cooling, cooling ponds, or hybrid cooling (NRC 2013a). The magnitude of the impact would depend on plant-specific characteristics of the cooling system (including location, intake velocities, screening technologies, and withdrawal rates) and characteristics of the aquatic resource (including population distribution, status, management objectives, and life history). However, for operating plants with closed-cycle cooling, the License Renewal GEIS generically concluded that impingement and entrainment is SMALL (NRC 2013a). The main reason the License Renewal GEIS could generically conclude that the impacts would be SMALL at all closed-cycle cooling plants is because power plants with closed-cycle cooling require much less water than those with once-through cooling. For example, EPRI estimated that the average flow rate for a reference 1,000-MW(e) nuclear plant with closed-cycle would be 45,000 L/min (12,000 gpm), which is approximately 1 to 3 percent of the flow rate for a reference 1,000-MW(e) plant with once-through cooling, 1,577,000 to 3,800,000 L/min (416,700 to 1,000,000 gpm) (EPRI 2002). Reactors are typically cooled either by transferring excess heat directly to a water source (referred to as open-cycle cooling) or to the atmosphere through a cooling tower (referred to as closed-cycle cooling). For nuclear power plants with closed-cycle cooling systems, cooling water for the service-water system (which cools the spent fuel pool) is usually withdrawn from a surface waterbody, circulated through the service-water system, and sent to the cooling tower as a source of makeup water for the main cooling system. While it is typically used as a source of makeup water, the discharge from the service-water system can also be returned to the surface waterbody, functioning, in essence, like an open-cycle cooling system. Because the heat load associated with the spent fuel pool during continued storage is significantly smaller than a reactor at full power and because of the costs associated with operating the cooling towers, the NRC assumes that, for nuclear power plants with closed-cycle cooling systems, those systems will be operated in a manner similar to an open-cycle cooling system to cool the spent fuel pool during the short-term timeframe. As discussed below, the NRC expects that the flow rate associated with the water needed to cool the spent fuel pool after operations will be significantly less than the overall water needed during operation of the reactors, regardless of the cooling technology used to cool the reactors. When compared to a once-through cooling system, the water needed to cool the spent fuel pool is orders of magnitude less than the water needed during reactor operations.

To operate spent fuel pools during short-term storage, the service-water system would likely continue to operate to cool the spent fuel pools. Cooling systems associated with spent fuel pools require substantially less water volume and carry a lower heat load than operating nuclear power plants, as indicated in Table 4-1. For example, based on the current operation of spent fuel pools, the NRC estimates that approximately 10,600 L/min (2,800 gpm) would be withdrawn at each spent fuel pool. Operating reactors with closed-cycle cooling systems, on the other hand, withdraw approximately 45,400 L/min (12,000 gpm) and operating plants with once-through cooling require 1,577,000 to 3,800,000 L/min (416,700 to 1,000,000 gpm) (EPRI 2002).

In addition, the amount of water withdrawn to cool spent fuel pools is likely to decrease over the short-term storage timeframe because the spent fuel pool would require less cooling as the spent fuel cools. Based on the reduced operational requirements for spent fuel pool cooling systems (e.g., reduced water-withdrawal and discharge rates), the impingement and entrainment impacts from an operating nuclear plant bound the potential impacts from operating spent fuel pools during short-term storage.

Because operating the spent fuel pool cooling system during the short-term timeframe will use less water than operating the cooling system for an operating plant with a closed-cycle cooling system, which was considered in the License Renewal GEIS, the NRC concludes that impingement and entrainment impacts from operating spent fuel pools during continued storage would have minor impacts on aquatic resources.

Heat Shock

Water-based cooling systems for spent fuel pools generally discharge heated effluent into nearby waterbodies. Heat shock can occur if the water temperature meets or exceeds the thermal tolerance of a species for some duration (NRC 2007a). In most situations, fish are capable of moving out of an area that exceeds their thermal tolerance limits, although many aquatic resource species lack such mobility. Heat shock is typically observable only for fish species, particularly those that float when dead. The License Renewal GEIS provides additional details on observed fish kills and other potential environmental impacts from heat shock.

The severity of impacts for heat shock depends on the characteristics of the cooling system (including location and type of discharge structure, discharge velocity and volume, and three-dimensional characteristics of the thermal plume) and characteristics of the affected aquatic resources (including the species present and their physiology, habitat, population distribution, status, management objectives, and life history). Site-specific design features, such as locating the discharge structures in areas where warmer water would be rapidly diluted, may mitigate adverse thermal effects (Beitinger et al. 2000). Hall et al. (1978) determined that the potential for thermal discharge impacts is greatest in shallow, enclosed, and poorly mixed waterbodies.

The License Renewal GEIS concluded that for operating plants with a once-through cooling system or cooling ponds, the level of impact for thermal discharge on aquatic biota (primarily due to heat shock) was SMALL at many plants and MODERATE or LARGE at some plants. For example, some nuclear plants have reported occasional fish kills from heat shock (see, e.g., NRC 2006b, 2007a; Exelon 2001, 2005). For operating plants with closed-cycle cooling, the NRC conducted a review of the literature and license renewal SEISs published to date and determined that reduced populations of aquatic biota attributable to occurrences of heat shock have not been reported for any existing nuclear power plants with cooling towers operated in closed-cycle mode. Based on this review and because of the smaller thermal plumes at plants

Environmental Impacts of At-Reactor Continued Storage of Spent Fuel

with closed-cycle cooling compared to plants with once-through cooling systems, the License Renewal GEIS concluded that impacts from heat shock would be SMALL at all plants with closed-cycle cooling. The thermal plume is generally smaller at plants with closed-cycle cooling because less water is being discharged (NRC 2013a).

As described above, cooling systems associated with spent fuel pools operating during the short-term storage timeframe would require substantially less water volume and carry a lower heat load compared to operating nuclear power plants with closed-cycle cooling systems (see Table 4-1). In addition, the heat load in the spent fuel pool would decrease over time as the fuel continues to decay. Because the amount of water discharged from a spent fuel pool, regardless of the type of cooling system, would still be significantly less than the amount of water discharged from an operating plant with closed-cycle cooling, the extent of the thermal plume would likely be smaller. In addition, the licensee would be required to obtain an NPDES permit for thermal discharges, and the permit would limit the amount and temperature of thermal effluent to be discharged. The NPDES permit would also require the licensee to monitor and ensure the effluent is within the set thermal limit. Based on this information, the thermal impacts from an operating nuclear plant with closed-cycle cooling (which was determined to be SMALL in the License Renewal GEIS) likely bounds the potential thermal impacts from operating spent fuel pools beyond the licensed term of the nuclear plant.

The NRC has determined that thermal impacts from operating spent fuel pools beyond the licensed term of the plant would have a minor impact on aquatic resources because operating the spent fuel pool cooling system during the short-term storage timeframe will use less water than operating a closed-cycle cooling system for an operating reactor and a spent fuel pool considered in the License Renewal GEIS.

Water-Use Conflicts with Aquatic Resources at Plants with Cooling Ponds or Cooling Towers Using Makeup Water from a River

Water-use conflicts with aquatic resources could occur if water from a single waterbody is required to simultaneously cool a spent fuel pool; support aquatic resources, and support other water users (e.g., agricultural, municipal, or industrial users). A conflict could arise if the surface-water resource is diminished either because of decreased water availability due to droughts; increased demand for agricultural, municipal, or industrial usage; or a combination of factors. The License Renewal GEIS determined that water-use conflicts during plant operation are a concern for streams or rivers because of the duration of license renewal and potentially increasing demands on surface water. However, the water-withdrawal requirements for a spent fuel pool during short-term storage are considerably lower than for an operating plant (see Table 4-1). In addition, the spent fuel pool operator would be subject to applicable water appropriation or allocation permit requirements and NPDES permit provisions, which would limit the amount of water that could be withdrawn and the quality of effluent discharged, respectively, as previously described in Section 4.9.1.1. Because operating the spent fuel pool cooling

system during short-term storage will use significantly less water than operating the cooling system for an operating plant considered in the License Renewal GEIS, the NRC has determined that water-use conflicts from operating spent fuel pools during short-term storage would have minimal impacts on aquatic resources.

Other Potential Impacts from the Cooling System

The License Renewal GEIS determined that all other potential impacts on aquatic ecology from the operation of the cooling system would be SMALL at all nuclear power plants. These additional impacts include the following:

- cold shock, which can occur when organisms acclimated to the elevated temperatures of a thermal plume are abruptly exposed to temperature decreases when the artificial source of heating stops;
- the creation of thermal plume migration barriers, which would occur if the mixing zone of the thermal plume covers an extensive cross-sectional area of a river and exceeds the fish avoidance temperature (NRC 2013a);
- changes in the distribution of aquatic organisms;
- accelerated development of aquatic insect maturation due to warmer temperatures;
- stimulation of the growth of aquatic nuisance species;
- effects of cooling-water discharge on dissolved oxygen, gas supersaturation, and eutrophication;
- effects of nonradiological contaminants on aquatic organisms;
- exposure of aquatic organisms to radionuclides; and
- losses from predation, parasitism, and disease among organisms exposed to sublethal stresses.

In the License Renewal GEIS, the NRC determined that these impacts would be SMALL at all nuclear power plants. The NRC based its conclusion on the following:

- Any fill kills or other events related to the impacts described previously were relatively rare and did not result in population level impacts.
- The heat from the thermal plume usually dissipated rapidly.
- Heated plumes are often small relative to the size of the receiving waterbody. The License Renewal GEIS provides additional details regarding these potential impacts and the studies reviewed to support the SMALL conclusion.

Environmental Impacts of At-Reactor Continued Storage of Spent Fuel

In evaluating the exposure of aquatic organisms to radionuclides, the License Renewal GEIS reviewed scientific literature on the effects of radiological doses to biota, and compared those results with the dose rates that have been estimated for aquatic biota at several nuclear power plants, including plants with spent fuel pools. Based on this assessment, the NRC determined that exposure of aquatic organisms to radionuclides near nuclear power plants was sufficiently less than the DOE and IAEA guidelines for radiation dose rates from environmental sources. Further, the levels of plant effluents are limited by radiation standards for human exposure, and those limitations are generally considered to be sufficiently protective of biota other than human. Given that the License Renewal GEIS and site-specific analyses included potential impacts from both operating reactors and spent fuel pools, and that the frequency and quantity of radionuclides released will decrease after reactor shutdown, previous EISs for power reactors contain impact determinations that bound the effects of continued storage on aquatic resources.

As described above, the water-withdrawal rate, discharge rates, and extent of the thermal plume would be greater for an operating plant than a spent fuel pool during short-term storage (see Table 4-1). Based on this information, the other potential impacts from an operating a nuclear plant with closed-cycle cooling (which was determined to be SMALL in the License Renewal GEIS) likely bound the potential impacts from operating spent fuel pools during short-term storage. Because operating the spent fuel pool cooling system during short-term storage will use less water than operating the cooling system for an operating plant considered in the License Renewal GEIS, the NRC has determined that other potential impacts from operating spent fuel pools during the short-term storage timeframe would have minimal impacts on aquatic resources.

4.10.1.2 ISFSIs

The NRC reviewed example ISFSI EAs to inform its analysis of the environmental impacts of ISFSIs on aquatic resources during short-term storage.

During normal operations, ISFSIs do not require water for cooling and the facility would produce minimal gaseous or liquid effluents. Therefore, no water withdrawal or discharges would be associated with the operation of ISFSIs. Some maintenance activities could occur during ISFSI operation. However, impacts on any aquatic features would be minimal. Stormwater control measures, which would be required to comply with NPDES permitting, would also minimize the flow of disturbed soils or other contaminants into aquatic features. In addition, the plant operator would likely implement best management practices to minimize erosion and sedimentation and control any runoff, spills, or leaks (NRC 2005a, 2003). For example, the EAs for the Calvert Cliffs, Humboldt Bay, and Diablo Canyon ISFSIs did not identify any significant impacts on aquatic resources during normal operations of an onsite dry cask storage facility (NRC 2003, 2005a, 2012a). Consequently, given that ISFSIs do not require water for cooling

and the facility would produce minimal gaseous or liquid effluents, impacts on aquatic resources from the operation of ISFSIs during short-term storage would not have noticeable impacts on aquatic resources.

4.10.1.3 Conclusion

Given that the impacts associated with the operation of spent fuel pools would likely be bounded by the impacts analyzed in the License Renewal GEIS due to the lower withdrawal rates, lower discharge rate, smaller thermal plume, and lower heat content for a spent fuel pool compared to an operating reactor with closed-cycle cooling, the NRC concludes that impacts on aquatic resources from the operation of spent fuel pools during short-term storage would be minimal. In addition, the impacts from operation of at-reactor ISFSIs would be minimal because ISFSIs do not require water for cooling, produce minimal gaseous or liquid effluents, and ground-disturbing activities for ISFSI maintenance would have minimal impacts on aquatic ecology. Therefore the NRC concludes that the potential environmental impacts on aquatic resources would be SMALL during the short-term storage timeframe.

4.10.2 Long-Term Storage

Routine maintenance and monitoring of the ISFSIs would continue during long-term storage. Likewise, the impacts from routine maintenance and monitoring of ISFSIs during the short-term storage timeframe would continue during the long-term storage timeframe and would remain the same.

Due to the relatively small construction footprint of a DTS, a DTS could likely be sited and constructed on land near existing facilities, on previously disturbed ground, and away from sensitive aquatic features. In addition, the replacement DTS and ISFSI facilities could likely be sited on previously disturbed ground away from sensitive aquatic features. For example, the NRC did not identify any significant impacts on aquatic resources from construction of the Humboldt Bay ISFSI in part due to the fact that ground-disturbing activities would be limited to 0.4 ha (1 ac) and the ISFSI was not located near any aquatic features (NRC 2005a). Similarly, the construction footprint for the Diablo Canyon ISFSI was limited to 2 ha (5 ac) and was sited in a previously disturbed area that did not contain any sensitive aquatic features (NRC 2003). In addition, the NRC (2003, 2005a) indicated that controls would be in place to minimize the flow of any site runoff, spillage, and leaks into sensitive aquatic features. For example, stormwater control measures, which would be required to comply with NPDES permitting, would minimize the flow of disturbed soils or other contaminants into aquatic features. The plant operator could also implement best management practices to minimize erosion and sedimentation.

ISFSIs and DTSs do not require water for cooling and produce minimal gaseous or liquid effluents. In addition, replacement ISFSIs and DTSs would be sited on previously disturbed

ground away from sensitive aquatic features. The older ISFSIs and DTSSs would be demolished and the land reclaimed. Therefore, the NRC concludes that impacts on aquatic resources during long-term storage would be SMALL.

4.10.3 Indefinite Storage

During indefinite storage, the activities that occur during long-term storage would continue and the ISFSIs and DTSSs would be replaced every 100 years. Therefore the impacts that occurred during long-term storage would continue. The NRC concluded in Section 4.10.2 that impacts on aquatic resources would be SMALL because ISFSIs do not require water for cooling and would have minimal impacts on aquatic resources. In addition, replacement of the ISFSIs and DTSSs would occur near existing facilities and would be sited on previously disturbed ground away from sensitive aquatic features. The older ISFSIs and DTSSs would be demolished and the land reclaimed. Therefore, the NRC concludes that the impacts on aquatic resources from indefinite storage of spent fuel in at-reactor ISFSIs would be SMALL.

4.11 Special Status Species and Habitat

This section describes potential environmental impacts on special status species and their habitats caused by the continued storage of spent fuel in spent fuel pools and at-reactor ISFSIs. Special status species and habitats may include those identified in Section 4.9 for terrestrial resources and Section 4.10 for aquatic resources.

4.11.1 Short-Term Storage

Impacts on Federally listed species, designated critical habitat, essential fish habitat, and other special status species and habitats during short-term storage may occur from spent fuel pool or ISFSI operations.

4.11.1.1 Spent Fuel Pools

Given that Federally listed species, designated critical habitat, essential fish habitat, State-listed species, marine mammals, migratory birds, and bald and golden eagles may be affected by operation of cooling systems for nuclear power plants, special status species and habitats could also be affected by the operation of cooling systems for spent fuel pools during the short-term storage timeframe. Possible impacts on Federally listed species, designated critical habitat, essential fish habitat, State-listed species, marine mammals, migratory birds, and bald and golden eagles would be similar to those described in Sections 4.9.1 and 4.10.1 for terrestrial and aquatic resources.

The Endangered Species Act (ESA) forbids “take” of a listed species, where “take” means to “harass, harm, pursue, hunt, shoot, wound, kill, trap, capture, or collect, or attempt to engage in

any such conduct.” Prior to entering the short-term storage timeframe, the NRC would have addressed impacts on Federally listed species and designated critical habitats through the ESA Section 7 consultation process at the time of original licensing, license renewal of the power plant (including the spent fuel pool cooling system), and for any other agency action as defined by the ESA that could affect listed species. For agency actions as defined by the ESA where listed species or designated critical habitat may be affected, the NRC would initiate ESA Section 7 consultation with the National Marine Fisheries Service (NMFS) or the U.S. Fish and Wildlife Service (FWS). This consultation may be either formal or informal, depending on the specific adverse effect. In the case of an adverse effect for which the NRC would issue a biological assessment that initiates formal consultation, the FWS or NMFS would issue a Biological Opinion in accordance with the provisions of formal consultation at 50 CFR 402.14. The FWS or NMFS could issue, with a Biological Opinion, an incidental take statement that contains provisions exempting a certain incidental take of Federally listed species and reasonable and prudent measures necessary or appropriate to minimize impacts on Federally listed species and designated critical habitats.

After conclusion of an initial consultation, 50 CFR 402.16 directs Federal agencies to reinstate consultation where discretionary Federal involvement or control over the action has been retained or is authorized by law, and where (a) the amount or extent of taking specified in the incidental take statement is exceeded, (b) new information reveals effects on Federally listed species or designated critical habitats that were not previously considered, (c) the action is modified in a manner that causes effects not previously considered, or (d) new species are listed or new critical habitat is designated that may be affected by the action. For example, the Oyster Creek nuclear plant exceeded its incidental take limit established by the NMFS for Kemp’s ridley sea turtles. The NRC, therefore, was required to reinstate ESA Section 7 consultation with NMFS, which included the reevaluation of the impacts on the Kemp’s ridley sea turtles and potential mitigation measures (NRC 2013a). Thus, the ESA Section 7 consultation process would help identify any impacts on Federally listed species or designated critical habitat, potentially require monitoring and mitigation to minimize impacts on listed species, and ensure that any takes that occur as a result of cooling-system operations are exempted by the incidental take statement. Regulations and guidance regarding the ESA Section 7 consultation process are provided in 50 CFR Part 402 and in the *Endangered Species Consultation Handbook* (FWS/NMFS 1998), respectively.

Federally listed species and designated critical habitats would continue to be protected under the ESA during the short-term storage timeframe. As described above the NRC would be required to reinstate consultation with the FWS and NMFS for NRC actions as defined in the ESA that could affect listed species. For example, for nuclear power plants with a Biological Opinion, the NRC would need to reinstate consultation with the FWS or NMFS if there is a significant change in the plant parameters described in the Biological Opinion that could affect listed species or designated critical habitats in a manner or to an extent not previously

Environmental Impacts of At-Reactor Continued Storage of Spent Fuel

considered and if the criteria in 50 CFR 402.16 are met for reinitiation of Section 7 consultation. The most likely change in a plant parameter during short-term storage would be a decrease in water-withdrawal and discharge rates due to the lower water demands to operate a spent fuel pool than to operate a nuclear power reactor. Impacts on special status species and habitats would likely decrease due to less impingement, entrainment, and thermal impacts associated with lower withdrawal and discharge rates.

If operation of the spent fuel pool cooling system resulted in a “take” of a listed species not covered under a Biological Opinion and if the criteria in 50 CFR Part 402 are met for initiation or reinitiation of Section 7 consultation, the NRC would be required to initiate or reinitiate ESA consultation with the FWS or NMFS. The official lists of ESA-listed species are updated by the FWS and NMFS. Species may be added to the list or delisted. If new species were listed under the ESA, the NRC would assess any potential impacts on those species at all NRC-licensed facilities at the time of listing. Therefore, if a new species were listed after the licensed life of the associated nuclear reactor, and if the criteria in 50 CFR Part 402 are met for initiation of Section 7 consultation, the NRC would determine if the newly listed species could occur near a spent fuel pool and would initiate ESA Section 7 consultation if operation of a spent fuel pool could adversely affect the newly listed species.

The NRC is required under the Magnuson–Stevens Fishery Conservation and Management Act to consult with NMFS for any authorized, funded, or undertaken action, including permitting and licensing, that could adversely affect essential fish habitat. As part of this consultation, the NRC would assess the occurrence of and adverse impacts to essential fish habitat in an Essential Fish Habitat Assessment. The implementing regulations for the Magnuson–Stevens Fishery Conservation and Management Act (50 CFR Part 600) describe additional details regarding the steps involved in essential fish habitat consultation.

In addition, NRC and licensee coordination with other Federal and State natural resource agencies would further encourage licensees to take appropriate steps to avoid or mitigate impacts on special status species, habitats of conservation concern, and other protected species and habitats, such as those protected under the Fish and Wildlife Coordination Act, Coastal Zone Management Act, Marine Mammal Protection Act, the Migratory Bird Treaty Act, and the Bald and Golden Eagle Protection Act, as applicable. NRC and licensee coordination with other Federal and State natural resource agencies would likely result in avoidance or mitigation measures that would minimize impacts on protected species and habitats.

4.11.1.2 ISFSIs

Impacts from the operation of ISFSIs on special status species and habitats would be similar to those described above for terrestrial and aquatic resources, which would be minimal due to the small size of the ISFSIs and because no water is required for cooling. For example, the NRC’s

EAs for the Humboldt Bay and Diablo Canyon ISFSIs did not identify any impacts on special status species during normal operations of at-reactor ISFSIs (NRC 2003, 2005a).

As described in Section 4.11.1.1, the NRC is required to consult with NMFS for actions that may adversely affect essential fish habitat. However, it is unlikely that ISFSIs would adversely affect essential fish habitat because they are built on land and do not require water for cooling. In the event that an ISFSI could adversely affect essential fish habitat, the NRC would consult with NMFS.

In addition, NRC and licensee coordination with Federal and State natural resource agencies would further encourage licensees to take appropriate steps to avoid or mitigate impacts on State-listed species, habitats of conservation concern, and other protected species and habitats, such as those protected under the Fish and Wildlife Coordination Act, Coastal Zone Management Act, Marine Mammal Protection Act, the Migratory Bird Treaty Act, and the Bald and Golden Eagle Protection Act, as applicable. NRC and licensee coordination with other Federal and State natural resource agencies would likely result in avoidance or mitigation measures that would minimize impacts on protected species and habitats.

4.11.1.3 Conclusion

As described above, the ESA has several requirements that would help ensure protection of Federally listed species and designated critical habitat during short-term storage. For spent fuel pools, the NRC would have addressed impacts on Federally listed species and designated critical habitats through the ESA Section 7 consultation process at the time of original licensing, license renewal of the power plant (including the spent fuel pool cooling system), and for any other agency action as defined by the ESA that may affect listed species. Following the conclusion of an initial consultation, 50 CFR 402.16 directs Federal agencies to reinstate consultation in circumstances where discretionary Federal involvement or control over the action has been retained or is authorized by law and where (a) the amount or extent of taking specified in the incidental take statement is exceeded, (b) new information reveals effects on Federally listed species or designated critical habitats that were not previously considered, (c) the action is modified in a manner that causes effects not previously considered, or (d) new species are listed or new critical habitat is designated that may be affected by the action. During each consultation, the NRC would characterize the effects of spent fuel pools to listed species in terms of its ESA findings of (1) no effect, (2) may affect but is not likely to adversely affect, (3) may affect and is likely to adversely affect, or (4) likely to jeopardize the listed species or adversely modify the designated critical habitat of Federally listed species populations or their critical habitats. Similarly, in complying with the Magnuson–Stevens Fishery Conservation and Management Act, the NRC would report the effects of spent fuel pools in terms of the Act's required findings of (1) no adverse impact, (2) minimal adverse impact, or (3) substantial adverse impact on the essential habitat of Federally managed fish and shellfish populations. Impacts on other special status aquatic species, such as State-listed species,

Environmental Impacts of At-Reactor Continued Storage of Spent Fuel

would most likely be less than those experienced during the licensed life for operation of the reactor due to the smaller size of the spent fuel pool's cooling system and lower water demands when compared to those of an operating reactor.

For ISFSIs, given the small size and licensees' ability to site ISFSIs away from sensitive ecological resources, the NRC concludes that ISFSIs would likely have minimal impacts on State-listed species, marine mammals, migratory birds, and bald and golden eagles. In the unlikely situation that the continued operation of an ISFSI could affect Federally listed species or designated critical habitat, and if the criteria are met in 50 CFR Part 402 for initiation or reinitiation of ESA Section 7 consultation, the NRC would be required to initiate or reinitiate ESA Section 7 consultation with the NMFS or FWS. In the unlikely situation that the continued operation of an ISFSI could adversely affect essential fish habitat, and if the criteria are met in 50 CFR Part 600 for initiation of consultation under the Magnuson–Stevens Fishery Conservation and Management Act, the NRC would be required to initiate essential fish habitat consultation with NMFS.

4.11.2 Long-Term Storage

In addition to routine maintenance, operation, and monitoring of ISFSIs, impacts from the construction of a DTS and replacement of the DTS and ISFSIs on special status species and habitats would be similar to those described in Sections 4.9.2 and 4.10.2, which would be minimal due to the small size of the ISFSIs and DTSs and because no water is required for cooling. The same consultations and any associated mitigation requirements described in Section 4.11.1 would apply to construction of a DTS and replacement of the DTS and ISFSI during long-term storage. The NRC assumes that the ISFSIs and DTSs could often be sited to avoid Federally listed species and critical habitat due to the small size of the construction footprint and sufficient amount of previously disturbed areas on most nuclear power plant sites. For example, the EAs for the Humboldt Bay and Diablo Canyon ISFSIs did not identify any significant impacts on special status species from construction and normal operations of the at-reactor ISFSIs (NRC 2003, 2005a). In addition, coordination with Federal and State natural resource agencies would encourage licensees to take appropriate steps to avoid or mitigate impacts on State-listed species, habitats of conservation concern, and other protected species and habitats, such as those protected under the Fish and Wildlife Coordination Act, Coastal Zone Management Act, Marine Mammal Protection Act, the Migratory Bird Treaty Act, and the Bald and Golden Eagle Protection Act, as applicable. Therefore, the NRC concludes that construction of a DTS and the replacement of the DTS and ISFSI would likely have minimal impacts on State-listed species, marine mammals, migratory birds, and bald and golden eagles. In the unlikely situation that the continued operation of an ISFSI or operation of a DTS could affect Federally listed species or designated critical habitat, and if the criteria are met in 50 CFR Part 402 for initiation or reinitiation of ESA Section 7 consultation, the NRC would be required to initiate or reinitiate ESA Section 7 consultation with the NMFS or FWS. In the

unlikely situation that the continued operation of an ISFSI or operation of a DTS could adversely affect essential fish habitat, and if the criteria are met in 50 CFR Part 600 for initiation of consultation under the Magnuson–Stevens Fishery Conservation and Management Act, the NRC would be required to initiate essential fish habitat consultation with NMFS.

4.11.3 Indefinite Storage

The impacts of indefinite storage on special status species and habitats would be minimal and similar to those described in Sections 4.9.3 and 4.10.3. The same consultations and any associated mitigation requirements described in Section 4.11.1 would apply to the construction of the DTS and replacement of the DTS and ISFSI facilities during indefinite storage. For the reasons described in Section 4.11.2, the NRC concludes that the replacement of the DTS and ISFSI would likely have minimal impacts on State-listed species, marine mammals, migratory birds, and bald and golden eagles. In the unlikely situation that the continued operation of an ISFSI or operation of a DTS could affect Federally listed species or designated critical habitat, and if the criteria are met in 50 CFR Part 402 for initiation or reinitiation of ESA Section 7 consultation, the NRC would be required to initiate or reinitiate ESA Section 7 consultation with the NMFS or FWS. In the unlikely situation that the continued operation of an ISFSI or operation of a DTS could adversely affect essential fish habitat, and if the criteria are met in 50 CFR Part 600 for initiation of consultation under the Magnuson–Stevens Fishery Conservation and Management Act, the NRC would be required to initiate essential fish habitat consultation with NMFS.

4.12 Historic and Cultural Resources

This section describes potential impacts on historic and cultural resources caused by the continued storage of spent fuel in spent fuel pools and at-reactor ISFSIs.

The NRC is considering impacts on historic and cultural resources in this GEIS through implementation of its NEPA requirements in 10 CFR Part 51. This rulemaking is not a licensing action; it does not authorize the initial or continued operation of any nuclear power plant, and it does not authorize storage of spent fuel. Because the GEIS does not identify specific sites for NRC licensing actions, a NHPA Section 106 review has not been performed. However, the NRC complies with NHPA Section 106 and the implementing provisions in 36 CFR Part 800 in site-specific licensing actions. As discussed in Section 3.11, identification of historic properties, adverse effects, and potential resolution of adverse effects would be conducted through consultation and application of the National Register of Historic Places criteria in 36 CFR 60.4. This information would also be evaluated to determine the significance of potential impacts on historic and cultural resources in the NRC's environmental review documents.

Environmental Impacts of At-Reactor Continued Storage of Spent Fuel

As discussed in Section 3.11, most nuclear power plant sites are located in areas along waterways that people tended to settle near or travel along, so there is a potential for historic and cultural resources to be present. Waterways provided freshwater, the most abundant food sources, transportation, and trade routes. As a result, prehistoric era archaeological sites and historic-era sites tend to be found along these waterways (NRC 2013a). As part of the recent License Renewal GEIS update, the NRC reviewed historic and cultural resource reviews that were performed for 40 license renewals. In these reviews, historic and cultural resource sites tend to occur in the less-developed or undeveloped portions of the site away from the power block. Many applicants conducted surveys to identify historic and cultural resources for their site-specific reactor license renewal and new reactor license applications, and they have developed and implemented historic and cultural resource management plans and procedures that protect known historic and cultural resources and address inadvertent discoveries. However some licensees may not have historic and cultural resource management plans or procedures.

As discussed in Section 1.8, the NRC assumes that at-reactor ISFSIs are constructed onsite under a general or site-specific license during the term of reactor operations (including license renewal). NHPA Section 106 reviews are not conducted for construction of generally licensed ISFSIs, but have been and will continue to be performed for site-specific licensing actions (new reactor licensing, reactor license renewal, away-from-reactor ISFSIs, and specifically licensed at-reactor ISFSIs). In addition, as discussed in Section 3.11, less-developed or disturbed portions of a power plant site, including areas used to support construction of an at-reactor ISFSI (e.g., construction laydown areas), could still contain unknown historic and cultural resources.

As discussed in more detail below, the NRC recognizes that there is uncertainty associated with the degree of prior disturbance and the resources, if any, present in areas where future ground-disturbing activities (e.g., initial and replacement DTS and replacement ISFSI) could occur. The NRC cannot eliminate the possibility that historic and cultural resources would be affected by construction activities during the long-term and indefinite timeframes because the initial ISFSI could be located within a less-disturbed area with historic and cultural resources in close proximity. Further, resources may be present that would not have been considered significant at the time the initial or replacement facilities were constructed, but could become significant in the future. For example, an existing nuclear power plant could, in the future, be considered a significant historic and cultural resource if its design represents a major advancement in power plant technology.

4.12.1 Short-Term Storage

During the short-term storage timeframe, the spent fuel pool would remain in operation until the transfer of the spent fuel from the pool to an at-reactor ISFSI. As discussed in Section 3.11, ground-disturbing activities occurred during initial nuclear power plant construction, and much of

the land within and immediately surrounding the power block was extensively disturbed. This activity would have eliminated any potential for historic and cultural resources to be present in these portions of the power plant site (i.e., power block). Continued operations and maintenance activities associated with spent fuel pools would not affect historic and cultural resources because spent fuel pools are located in the fuel building within the power block and most resources would have been removed during initial plant construction.

As discussed in Section 3.11, less-developed or disturbed portions of a power plant site, including the areas that were used to support construction of the at-reactor ISFSI, could contain historic and cultural resources. For purposes of evaluating the impacts of continued storage in this GEIS, the NRC assumes that at-reactor ISFSIs are constructed during the period of reactor operations. Impacts associated with construction of an at-reactor ISFSI have already occurred and are not considered in the short-term storage timeframe. If ground-disturbing activities occur as a result of continued operations or maintenance, impacts could be mitigated if the licensee has previously identified historic and cultural resources and has management plans and protective procedures in place. Routine maintenance and continued operations of an at-reactor ISFSI are not expected to affect historic and cultural resources because no ground-disturbing activities are anticipated. However, if ground-disturbing activities occur as a result of continued operations or maintenance, impacts could be mitigated if the licensee has previously identified historic and cultural resources and has management plans and protective procedures in place.

Because no ground-disturbing activities are anticipated during the short-term storage timeframe, there would be no impacts on historic and cultural resources. Therefore, impacts associated with continued operations and maintenance of the spent fuel pool and the at-reactor ISFSI on historic and cultural resources during the short-term timeframe would be SMALL.

4.12.2 Long-Term Storage

During the long-term timeframe, in addition to routine maintenance and monitoring, the NRC assumes that an at-reactor ISFSI will be replaced, which will require the construction and operation of a DTS. Further, the NRC assumes that the DTS is replaced once during the long-term timeframe.

Impacts from continued operations and routine maintenance of the at-reactor ISFSI and DTS during long-term storage would be similar to those described in the short-term storage timeframe. The impacts would be small because there would be no ground-disturbing activities as a result of the continued operations and routine maintenance.

NRC authorization to construct a DTS and replace a specifically licensed at-reactor ISFSI and DTS would constitute Federal actions under NEPA, would be undertakings under the NHPA, and would require a site-specific environmental review and compliance with NHPA requirements

Environmental Impacts of At-Reactor Continued Storage of Spent Fuel

before making a decision on the licensing action. In accordance with 36 CFR Part 800, a Section 106 review would be conducted for each undertaking to determine whether historic properties are present in the area of potential effect, and if so, whether these actions would result in any adverse effects on these properties. License applicants are required to provide historic and cultural resource information in their Environmental Reports. To prepare these assessments, applicants conduct cultural resource surveys of any areas of proposed development to identify and record historic and cultural resources. Impacts on historic and cultural resources would vary depending on what resources are present. Resolution of adverse effects, if any, should be concluded prior to the closure of the Section 106 process. For generally licensed ISFSIs, impacts could be avoided, minimized, or mitigated if the licensee has management plans or procedures that require consideration of these resources prior to engaging in ground-disturbing activities.

The NRC assumes that the replacement at-reactor ISFSI and initial and replacement DTS will be constructed on land near the existing facilities. As discussed in Section 3.11, ground-disturbing activities occurred during initial nuclear power plant construction, and much of the land within and immediately surrounding the power block was extensively disturbed. If replacement of the at-reactor ISFSI and placement of initial and replacement DTS occur within the power block, then impacts would likely be small because initial construction of the nuclear power plant would have eliminated any potential for historic and cultural resources to be present. However, ISFSIs are currently located outside the power block. If the replacement ISFSI and initial and replacement DTS are sited within previously disturbed areas, then impacts would likely be SMALL because initial construction of the ISFSI could have reduced the potential for historic and cultural resources to be present. However, if these facilities are located in less-developed or disturbed portions of a power plant site outside of the power block with historic and cultural resources present, including areas that were used to support construction of the at-reactor ISFSI, then there could be impacts to historic and cultural resources.

Given the minimal size of the replacement ISFSI and initial and replacement DTS, and the large land areas at nuclear power plant sites, licensees should be able to locate these facilities away from historic and cultural resources. However, the NRC recognizes that it may not be possible for a licensee to avoid adverse effects on historic properties under NHPA or impacts on historic and cultural resources under NEPA. As discussed previously, existing at-reactor ISFSIs were constructed outside of the power block in less-developed or disturbed areas; thus, undiscovered historic and cultural resources could be present. The NRC believes that it is reasonable to assume that the replacement ISFSI and the initial and replacement DTS would be constructed near existing facilities because licensees may have, through decommissioning activities, reduced the NRC-licensed area to a smaller area around ISFSIs, and licensees would already have characterized and selected initial ISFSI sites to meet NRC siting, safety, and security requirements. The NRC believes that it is reasonable to assume that licensees would generally

avoid siting and operating an ISFSI away from the existing licensed area or outside previously characterized areas. The magnitude of adverse effects on historic properties and impacts on historic and cultural resources during the long-term timeframe largely depends on where the facilities are sited, what resources are present, the extent of proposed land disturbance, whether the area has been previously surveyed to identify historic and cultural resources, and whether the licensee has management plans and procedures that are protective of historic and cultural resources. Even a small amount of ground disturbance (e.g., clearing and grading) could affect a small but significant resource. In most, but not all instances, placement of storage facilities on the site can be adjusted to minimize or avoid impacts on any historic and cultural resources in the area. Before these ground-disturbing activities occur, the site-specific environmental review and compliance with the NHPA process could identify historic properties and historic and cultural resources that could be impacted. Under the NHPA, mitigation does not eliminate a finding of adverse effect on historic properties; but, impacts would be assessed at the time of the future licensing action.

Based upon the considerations above, the potential impacts to historic and cultural resources during the long-term timeframe would range from SMALL to LARGE. This range takes into consideration routine maintenance and monitoring (i.e., no ground-disturbing activities), the absence or avoidance of historic and cultural resources, and potential ground-disturbing activities that could impact historic and cultural resources. In addition, the analysis considers uncertainties inherent in analyzing this resource area over long timeframes. These uncertainties include any future discovery of previously unknown historic and cultural resources; resources that gain significance within the vicinity and the viewshed (e.g., nomination of a historic district) due to improvements in knowledge, technology, and excavation techniques; and changes associated with predicting resources that future generations will consider significant. Potential adverse effects on historic properties or impacts on historic and cultural resources could be minimized through the development of agreements, license conditions, and implementation of the licensees' historic and cultural resource management plans and procedures to protect known historic and cultural resources and address inadvertent discoveries during construction of the replacement at-reactor ISFSI and initial and replacement DTS. If construction of a DTS and replacement of the ISFSI and DTS occurs in an area with no historic or cultural resources present or construction occurs in a previously disturbed area that allows avoidance of historic and cultural resources then impacts would be SMALL. By contrast, a MODERATE or LARGE impact could result if historic and cultural resources are present at a site and, because they cannot be avoided, are impacted by ground-disturbing activities during the long-term timeframe. Accordingly, the NRC has concluded that the impacts on historic and cultural resources for the long-term timeframe would be SMALL to LARGE.

4.12.3 Indefinite Storage

This section describes the potential environmental impacts on historic and cultural resources if a repository is not available to accept spent fuel. For this analysis, the NRC assumes that spent fuel would continue to be stored onsite indefinitely. During this timeframe, maintenance and monitoring would continue and the at-reactor ISFSI and DTS would be replaced every 100 years. The NRC assumes that the replacement of the at-reactor ISFSI and DTS would be constructed on land near existing facilities. As stated in Section 1.8, the NRC assumes that the land where the original facilities were constructed would be available for replacement facility construction; however, the NRC cannot eliminate the possibility that historic and cultural resources would be affected by construction activities during the indefinite timeframe because the initial ISFSI could be located within a less-disturbed area with historic and cultural resources in close proximity. Further, resources may be present that would not have been considered significant at the time the initial or replacement facilities were constructed, but could become significant in the future. Impacts regarding the replacement of the ISFSI and DTS would be similar to those described in the long-term storage timeframe.

Based upon the considerations above, the potential impacts to historic and cultural resources during the indefinite storage timeframe would range from SMALL to LARGE. This range takes into consideration routine maintenance and monitoring (i.e., no ground-disturbing activities), the absence or avoidance of historic and cultural resources, and potential ground-disturbing activities that could impact historic and cultural resources. In addition, the analysis considers uncertainties inherent in analyzing this resource area over long timeframes. These uncertainties include any future discovery of previously unknown historic and cultural resources; resources that gain significance within the vicinity and the viewshed (e.g., nomination of a historic district) due to improvements in knowledge, technology, and excavation techniques or changes associated with predicting resources that future generations will consider significant. Potential adverse effects on historic properties or impacts on historic and cultural resources could be minimized through development of agreements, license conditions, and the implementation of the licensees' historic and cultural resource management plans and procedures to protect known historic and cultural resources and address inadvertent discoveries during construction of the replacement at-reactor ISFSI and replacement DTS. If construction of a DTS and replacement of the ISFSI and DTS occurs in an area with no historic or cultural resource present or construction occurs in previously a disturbed area that allows avoidance of historic and cultural resources then impacts would be SMALL. By contrast, a MODERATE or LARGE impact could result if historic and cultural resources are present at a site and, because they cannot be avoided, are impacted by ground-disturbing activities during the indefinite timeframe. Accordingly, the NRC has concluded that the impacts on historic and cultural resources for the indefinite timeframe would be SMALL to LARGE.

4.13 Noise

This section describes potential noise impacts caused by the continued storage of spent fuel in spent fuel pools and at-reactor ISFSIs.

4.13.1 Short-Term Storage

During short-term storage, spent fuel pool systems would remain in operation to ensure adequate cooling prior to the transfer of spent fuel from the pools to an at-reactor ISFSI. Most noise would be generated when spent fuel is transferred from the spent fuel pool to the ISFSI. Once reactor operations cease, there would be less noise generated because some of the noise-generating equipment and activities would either cease or operate at lower levels. Therefore, short-term storage noise levels would be less than reactor operation noise levels.

The License Renewal GEIS (NRC 2013a) analyzed the environmental impacts associated with continued reactor operations during the license term of a nuclear power plant. Facility noise levels at operating reactor sites may sometimes exceed 55 dB(A) over a 24-hour period, which is the threshold EPA identified to protect residential areas against excess noise during outdoor activities (NRC 2013a; EPA 1974). As discussed in Section 3.12, the primary factors that influence impact magnitude are the noise level of the source and the proximity of the source to the receptor. Proximity matters because noise levels decrease as distance from the source increases. For point sources like stationary equipment, noise is reduced by about 6 dB(A) for each doubling of distance from the source, and for a line source, like a road, noise is reduced by 3 dB(A) per doubling of the distance (Washington State Department of Transportation 2014). As stated in the License Renewal GEIS (NRC 2013a), in most cases, the sources of noise are far enough away from sensitive receptors that the noise is attenuated to nearly ambient levels and is scarcely noticeable. However, in some cases noise from reactor operations can be detected relatively close to the site boundary and create a minor nuisance.

As described earlier in this section, noise levels would be lower once reactor operations cease. Noise sources associated with spent fuel pool storage include water cooling-system equipment, spent fuel-handling equipment, and in some cases vehicles to transport spent fuel from pools to dry cask storage pads. Some of the noise from equipment associated with spent fuel pool storage is attenuated because the activities occur inside a building, which functions as a noise barrier. Spent fuel handling and transfer would be infrequent, so the noise generated from these activities would also occur infrequently. Typically, pool storage sites produce no noise impacts on the local environment (NRC 2004c).

As described in Section 3.12, spent fuel casks resting on concrete pads are essentially passive, without any sources generating noise. Noise from routine maintenance and monitoring as well as from ancillary activities such as operation of the administration buildings would be minimal.

Environmental Impacts of At-Reactor Continued Storage of Spent Fuel

Even in rare cases where an independently operating spent fuel pool causes noise impacts that exceed the EPA-recommended threshold for outdoor noise, licensees are usually able to make engineering changes to address the problem. For example, at the Maine Yankee nuclear power plant the licensee set up the pool storage operations to operate independently from the reactor, which was being decommissioned. The fans used as part of the spent pool cooling-system generated noise levels up to 107 dB, which attenuated to 50 dB less than 1.6 km (1 mi) away (NRC 2002b). This noise level exceeded the 55 dB(A) threshold recommended by the EPA for protection against outdoor activity interference and annoyance. Nearby residents complained to the plant staff about the noise level, and the licensee made engineering changes to the fans that were causing the noise and the issue was resolved.

In conclusion, the operation noise levels, duration, and distance between the noise sources and receptors generally do not produce noise impacts noticeable to the surrounding community. In certain cases, such as the Maine Yankee spent fuel pool island, potential noise impacts on receptors closest to the site property line can experience unmitigated noise levels that exceed EPA-recommended noise levels. However, noticeable noise levels are generally not expected and would be limited to the nearest receptors. Therefore, the NRC concludes that the overall impact from noise during short-term storage would be SMALL.

4.13.2 Long-Term Storage

In addition to routine maintenance and monitoring, the NRC assumes that long-term storage would include the construction, operation, and replacement of a DTS and the replacement of the ISFSI. Construction of a DTS would generate higher noise levels than DTS operations. The NRC assumes that DTS construction would take 1–2 years. Construction equipment would be used to grade and level the site, excavate the facility foundation, handle building materials, and build the facility. Construction equipment generates noise levels over 90 dB(A) (at a reference distance of 15 m [50 ft] from the source) (NRC 2002b). At distances greater than about 1.6 km (1 mi), expected maximum noise levels from construction equipment would be reduced to about 55 dB(A), which is the EPA-recommended level for protection in residential areas against outdoor activity interference and annoyance (NRC 2002b).

During operation of the DTS, some activities would be conducted inside the building, which functions as a noise barrier. Spent fuel transfer between the storage pad and the DTS would be infrequent. The NRC expects noise levels from this transfer of spent fuel to be no more than the noise level generated transferring spent fuel from the pool to the dry pad, as described in Section 4.13.1. In addition, some of the reactor and spent fuel pool storage noise sources present during short-term storage (such as the cooling towers and associated equipment) would not be present during long-term storage.

The NRC assumes that the at-reactor ISFSI (i.e., concrete storage casks and pads) and the DTS would be replaced within the 100-year timeframe. Similar to the DTS construction, ISFSI and DTS replacement uses construction equipment, which can generate noise levels over

90 dB(A). The noise levels exceed the EPA-recommended level for protection against outdoor activity interference and annoyance (NRC 2002b). However, distance from the source will eventually reduce the noise level to below the EPA-recommended level for protection against outdoor activity interference and annoyance.

Construction and replacement of the DTS, although temporary and representing a small portion of the overall long-term storage timeframe, would generate noise levels that exceed EPA-recommended noise levels. Operational noise levels would not produce noise impacts noticeable to the surrounding community. For some activities (e.g., replacement of the DTS and ISFSI facilities), potential noise impacts on receptors closest to the site property line can experience unmitigated noise levels that exceed EPA-recommended noise levels. However, these activities are temporary and noticeable noise levels would be limited to the nearest receptors. Therefore, the NRC concludes that the overall impact from noise during long-term storage would be SMALL.

4.13.3 Indefinite Storage

This section describes the noise impacts in the event a repository is not available to accept spent fuel and the spent fuel must be stored indefinitely in ISFSIs. Impacts from indefinite storage would be similar to those described for the long-term storage timeframe. The NRC does not anticipate that indefinite storage in an ISFSI would generate any new or additional noise in comparison with the noise impacts described for the long-term storage timeframe. Therefore, the NRC concludes that the overall impact from noise during indefinite storage would be SMALL.

4.14 Aesthetics

This section describes potential impacts on aesthetic resources caused by continued storage of spent fuel in spent fuel pools and at-reactor ISFSIs.

4.14.1 Short-Term Storage

No changes to nuclear power plant structures will be required for continued operation of the spent fuel pool during continued storage, including routine maintenance and monitoring.

In the License Renewal GEIS, the NRC determined that the aesthetic impacts associated with continued operation of a nuclear power plant, which included the continued operation of the spent fuel pool, were SMALL because the existing visual profiles of nuclear power plants were not expected to change during the license renewal term (NRC 2013a). Therefore, the NRC concludes that the potential impacts from the short-term continued operation of the spent fuel pool would be of minor significance to aesthetic resources.

Environmental Impacts of At-Reactor Continued Storage of Spent Fuel

For at-reactor ISFSIs, NRC evaluations of existing ISFSIs have found the aesthetic impacts to be SMALL. For example, the NRC found that continued operation of the Calvert Cliffs ISFSI would have a SMALL impact on aesthetic resources in part because there would be no new construction at the facility (NRC 2012a). Similarly for Humboldt Bay, the NRC determined that the aesthetic impact would be minimal (NRC 2005a), because the Humboldt Bay ISFSI is an in-ground vault with a low visual profile. Given that the NRC assumes that all ISFSIs are constructed during the nuclear power reactor's licensed life for operation, the visual profile of at-reactor ISFSIs during short-term storage is expected to be the same after the permanent cessation of reactor operations. The NRC therefore believes that potential impacts from short-term continued storage in at-reactor ISFSIs would be of minor significance to aesthetic resources.

This assessment of visual impacts depends in part on the degree of public interest and concern about potential changes to the existing scenic quality. However, because no changes to the visual profile are likely to occur as a result of the continued operation and maintenance of the existing spent fuel pool and ISFSI, the NRC concludes that the impacts from short-term storage of spent fuel on aesthetics would be SMALL.

4.14.2 Long-Term Storage

As discussed in the previous section, routine maintenance is not expected to have an impact on aesthetic resources. The NRC assumes that a DTS would need to be constructed during the long-term storage timeframe. Construction and operation of a DTS would have limited impacts on aesthetic resources. A DTS (approximately 7.9 m × 5.5 m [26 ft × 18 ft] and about 14 m [47 ft] tall) is likely to have a larger visual profile than other ISFSI structures; however, it would not be expected to provide a significant visual contrast to the surrounding landscape. There would be temporarily adverse impacts on aesthetic resources during construction of the DTS, resulting from the presence and operation of the construction equipment used to build the facility. However, because a DTS is a relatively small facility (e.g., compared to a nuclear power plant) and many of the internal components of the facility would be prefabricated, the construction of a DTS would take less time and equipment to build, and it would have a minimal impact on aesthetic resources.

Replacement of the ISFSIs and DTSs within the 100-year timeframe would occur on land near existing facilities. The NRC assumes that the overall land disturbed, and hence the visual profile of the facility, would not increase because the old ISFSIs and DTSs would be demolished and the land reclaimed. Impacts on aesthetic resources would likely temporarily increase during the period of construction of the new facilities and demolition of the old, when the most visible features are likely to be equipment associated with cask handling. Aesthetic impacts from such equipment and its operation would be minimal.

Because continued operation of the ISFSI, construction and operation of the DTS, and replacement of the ISFSIs and DTSs would not significantly alter the landscape of an at-reactor ISFSI, the NRC concludes that the potential environmental impacts on aesthetic resources during long-term storage would be SMALL.

4.14.3 Indefinite Storage

If a repository is not available, current practices of using at-reactor ISFSIs are expected to continue indefinitely. At the end of each 100-year cycle, the previously reclaimed land would be used to construct the replacement ISFSIs and DTSs. The potential activities and their impacts would be the same as those described in Section 4.14.2 for long-term storage, but would continue to occur repeatedly. Therefore, the NRC concludes that the indefinite onsite storage of spent fuel would result in SMALL impacts on aesthetic resources.

4.15 Waste Management

This section describes potential environmental impacts from low-level radioactive waste (LLW), mixed waste, and nonradioactive waste management and disposal caused by the continued storage of spent fuel in spent fuel pools and at-reactor ISFSIs.

Section 3.14 identified the types of waste generated by continued storage of spent fuel, including LLW, mixed waste, hazardous waste, and nonradioactive, nonhazardous waste. The environmental impacts of hazardous waste and nonradioactive, nonhazardous waste are discussed together in this section as nonradioactive waste, unless otherwise noted.

Impacts from the transportation of waste are discussed in Section 4.16. The public and occupational health impacts associated with at-reactor radioactive waste-management activities at nuclear plants are addressed in Section 4.17.

4.15.1 Short-Term Storage

The impacts associated with the management and disposal of LLW, mixed waste, and nonradioactive waste during short-term continued storage are discussed in the following sections.

4.15.1.1 Low-Level Radioactive Waste

The continued operation of a spent fuel pool would generate minimal amounts of LLW such as wet wastes from processing and recycling contaminated liquids. In the License Renewal GEIS, the environmental impacts associated with the management, onsite storage, and disposal of LLW for an additional 20 years of operation were determined to be SMALL during normal reactor operation (NRC 2013a). The NRC concluded impacts from LLW would be SMALL.

Environmental Impacts of At-Reactor Continued Storage of Spent Fuel

because of the regulatory controls in place, low public dose being achieved, and reasonable assurance that sufficient LLW disposal capacity will be made available when needed for facilities to be decommissioned.

The amount of LLW generated from the operation and maintenance of an at-reactor ISFSI during short-term storage is expected to be minimal. For example, in the Calvert Cliffs ISFSI renewal EA (NRC 2012a), the NRC determined that the impacts from waste management would be SMALL, mainly because of the small quantities of LLW being generated and the fact that those wastes would be handled and disposed of according to regulatory requirements.

Comprehensive regulatory controls, facilities, and procedures are in place at operating reactors to ensure that the LLW is properly handled and stored and that doses and exposure to the public and the environment are negligible at all plants (NRC 2013a). These same regulatory controls are expected to remain in effect during short-term continued storage of spent fuel.

Because short-term continued storage of spent fuel would generate much less LLW than an operating reactor and licensees would continue to implement Federal and State regulations and requirements for proper management and disposal of LLW, the NRC concludes that the environmental impact from the management and disposal of LLW would be SMALL for all waste-management facilities.

4.15.1.2 Mixed Waste

The amount of mixed waste generated from the operation and maintenance of the spent fuel pool and the ISFSI is expected to be minimal compared to that of an operating reactor. After reactor operations cease, most waste-generating activities, as described in Section 3.14, would also cease, except for those associated with continued storage.

In the License Renewal GEIS, the NRC determined that the radiological and nonradiological environmental impacts from the storage and disposal of mixed waste would be SMALL for all operating reactor sites (NRC 2013a) because of the small quantities generated and comprehensive regulatory controls in place to ensure that this waste is properly managed and that doses to the public and environment are negligible. In addition, as an example, the EIS for the Fermi Unit 3 combined license states that 0.416 m³/yr (0.544 yd³/yr) of mixed waste would be generated during operation. Because the amount of mixed waste generated during short-term continued storage would be less than the relatively small amount estimated for reactor license renewal, the impacts in the License Renewal GEIS would bound the impacts for mixed waste during continued storage.

Comprehensive regulatory controls, facilities, and procedures are expected to remain in place during short-term continued storage of spent fuel, which will ensure that mixed waste is properly managed so that exposure to the public and the environment are negligible at all storage sites.

Because short-term storage of spent fuel would generate much less mixed waste than an operating reactor and licensees would continue to implement Federal and State regulations regarding proper management and disposal of mixed waste, the NRC concludes that the environmental impacts from the management and disposal of mixed waste would be SMALL.

4.15.1.3 Nonradioactive Waste

The amount of nonradioactive waste generated from the operation and maintenance of an at-reactor ISFSI is expected to be minimal compared to that of an operating reactor. After reactor operations cease, most waste-generating activities would also cease, except for those associated with short-term storage.

The impacts associated with the storage and disposal of nonradioactive wastes at operating nuclear power plants were determined to be SMALL in the License Renewal GEIS (NRC 2013a), because although the quantities of waste generated are highly variable, they are generally less than amounts generated at other industrial facilities. After reactor operations cease, most waste-generating activities would also cease, except for those associated with continued storage. Because the amount of waste generated during short-term storage would be less than that estimated for reactor license renewal, the impacts in the License Renewal GEIS would bound the impacts for nonradioactive waste during short-term continued storage.

For example, in EISs for the licensing of new reactors (e.g., Fermi 3 and Lee), the impacts associated with the storage and disposal of nonradioactive waste, including hazardous waste, were determined to be SMALL, primarily because the wastes would be handled and disposed of according to County and State regulations (NRC 2013b,d).

The handling and disposal of hazardous wastes are regulated by the EPA or the responsible State agencies in accordance with the requirements of RCRA. Nonhazardous wastes are managed onsite and are generally disposed of in landfills permitted locally under RCRA Subtitle D regulations. Similar to LLW and mixed waste, nonradioactive waste would continue to be managed according to local, State, and Federal regulatory requirements.

Because short-term storage of spent fuel would generate less nonradioactive waste than an operating reactor, which was previously determined to have a SMALL impact, and licensees would continue to implement Federal and State regulations regarding proper management and disposal of nonradioactive waste, the NRC concludes that the environmental impact from the management and disposal of nonradioactive waste would be SMALL.

4.15.2 Long-Term Storage

Ongoing routine maintenance would continue to generate minimal amounts of waste. The NRC assumes that, during this long-term storage timeframe, a DTS would need to be constructed and operated. In addition, the DTS and ISFSI facilities (including casks and concrete pads) would need to be replaced.

4.15.2.1 Low-Level Radioactive Waste

Routine maintenance and monitoring of the ISFSI would continue to occur, which would generate minimal amounts of LLW. The NRC anticipates no LLW would be generated by onsite construction activities associated with the DTS.

During long-term storage, storage canisters will reach the end of their design life and require replacement. The replacement process will involve the transfer of spent fuel assemblies to new canisters and decontamination and disposal of the old canisters. The repackaging process is expected to generate types of dry wastes similar to those described for normal operations (e.g., clothing and tools) and radioactively contaminated storage canisters that would be handled and disposed of as LLW. Because storage canisters come into direct contact with spent fuel, it is possible that the metal components could become contaminated or activated and require disposal as LLW (EPRI 2010).

All spent fuel repackaging would be performed in the DTS. The repackaging process consists of removal of the spent fuel assemblies from the old canister and their placement into a new canister. For example, in the Calvert Cliffs ISFSI renewal EA (NRC 2012a), the NRC estimated that less than 0.06 m³ (2 ft³) per canister of LLW would be generated during cask loading and decontamination, based on a horizontal storage module design such as that described in Section 2.1.2.2. This LLW would consist of garments, tapes, and cloths, and would be processed by compaction. In addition, the old canister would require disposal. Because storage canisters come into direct contact with spent fuel for an extended period of time, it is assumed that the dry storage canister and any internal components have become activated or radioactively contaminated and require disposal as LLW (EPRI 2010). For example the NUHOMS 32P-S100 dry storage canister licensed for use at the Calvert Cliffs ISFSI has a compacted nominal volume of 1.3 m³ (1.7 yd³) (Transnuclear, Inc. 2004) that must be managed and disposed of as LLW. Repackaging and replacement of 150 canisters would generate approximately 1953 m³ (255 yd³) of compacted LLW.

In addition to repackaging the spent fuel during long-term storage, the ISFSI would need to be replaced. For purposes of this analysis, because the activities associated with the replacement and demolition of the ISFSI are similar to decommissioning activities, the quantities of LLW generated from the replacement of casks, horizontal storage modules, and concrete pads are expected to be similar to those considered in decommissioning funding plans provided to the NRC in accordance with 10 CFR 72.30(b). For example, many plans state that no LLW will be generated from demolition of ISFSI structures because the dry cask storage systems are designed to prevent leaks and the contained spent fuel does not generate sufficiently high levels of neutron radiation to activate materials used in construction of the systems. However some plans state that neutron activation is possible (Duke Energy 2013, Pacific Gas and Electric Company 2012) and could result in quantities of LLW generated during ISFSI decommissioning from about 72 to 265m³ (94 to 346 yd³).

Environmental Impacts of At-Reactor Continued Storage of Spent Fuel

Replacing the DTS during long-term storage timeframe would result in a small amount of LLW generated from removing contamination from the DTS. The primary source of contamination is spalled crud from spent fuel cladding. However, the spent fuel is enclosed by a transfer tube through most of the spent fuel transfer process. The transfer tube is the only piece of equipment that will not be decontaminated and thus will need to be disposed of as LLW. All other major equipment and structures of the DTS will be decontaminated. The volume of LLW is estimated by DOE to be 20-40 55-gallon drums, or about 4 to 8 m³ (5 to 10 yd³) (DOE 1996).

In summary, LLW is generated during the long-term timeframe during spent fuel repackaging operations, by unloading and loading operations, compaction of canisters removed from service, by replacement of storage casks, horizontal storage modules, and concrete pads, and by replacement of the DTS. Using the maximum values in the range described above, this volume of LLW is expected to be no more than about 480 m³ (630 yd³).

The NRC previously determined that waste generated during reactor decommissioning would have a SMALL impact (NRC 2013a) and waste generated during ISFSI license renewal would also have a SMALL impact (NRC 2012a). The amount of LLW generated by the replacement of the ISFSI and DTS would be a fraction of the estimated over 7,000 m³ (over 9,000 yd³) of LLW generated during reactor decommissioning (NRC 1996). Because waste generated during the long-term storage timeframe would be less than that generated during reactor decommissioning, the NRC expects that LLW generated during replacement of an ISFSI and DTS would be minimal.

Because LLW would continue to be managed according to Federal regulations and the disposal capacity for LLW is expected to be available when needed (see Section 1.8.3), the NRC determines the impacts from LLW management and disposal would be SMALL during long-term storage.

4.15.2.2 Mixed Waste

Routine maintenance and monitoring of the ISFSI would continue during long-term storage, and would generate minimal amounts of mixed waste. The repackaging of spent fuel, construction and operation of a DTS, and the replacement of the ISFSIs and DTSSs are not expected to generate mixed waste. However, if mixed waste is generated, it would be a small fraction of that generated by an operating nuclear power plant and it would be managed according to regulatory requirements.

Due to the type of activities occurring during long-term storage that are expected to generate minimal to no mixed waste and because the quantity of mixed waste generated from the operation and replacement of the ISFSIs and DTSSs is expected to be a small fraction of that generated during the licensed life of the reactor, the radiological and nonradiological environmental impacts associated with the management and disposal of mixed waste are expected to be SMALL during long-term storage.

4.15.2.3 Nonradioactive Waste

Routine maintenance and monitoring of the ISFSI would continue to generate minimal amounts of nonradioactive waste. The construction and operation of a DTS would be expected to generate nonradioactive nonhazardous waste similar to that generated during ISFSI construction (e.g., construction debris, packaging material, and worker trash, and small quantities of nonradioactive hazardous wastes like paint waste, solvents, pesticides, and cleaning supplies).

Repackaging of the canisters could generate some amount of nonradioactive waste if the waste were never contaminated. Replacing the DTS and ISFSI facilities (including casks and storage pads), would generate nonradioactive waste primarily nonhazardous waste. The noncontaminated portions of the storage modules, concrete pads, and DTS building would be demolished and disposed of as construction debris in a landfill.

Similar to LLW estimates, the amount of nonradioactive waste generated from cask and facility replacement is based on decommissioning estimates. However, specific quantities of nonradioactive waste are difficult to estimate because the amount of waste will depend on whether the materials were contaminated during storage.

Based on the NUHOMS cask design described in Section 2.1.2.2, a single storage module volume is 50 m³ (65 yd³) of concrete and steel. The amount of material would be similar for vertical storage cask designs, as described in Section 2.1.2.2. Some portion of this volume would likely be disposed of as LLW due to contamination, but the majority of the waste would be disposed of as nonradioactive waste. A 1-m (3-ft) thick ISFSI pad capable of supporting 150 NUHOMS horizontal storage modules, based on the example facility described in Section 2.1.2.2, would contain about 13,200 m³ (17,300 yd³) of concrete that would need to be demolished and disposed of as demolition debris. The amount of concrete would be similar for vertical storage cask designs, as described in Section 2.1.2.2.

The NRC estimated the volume of nonradioactive (primarily nonhazardous) waste from the replacement of the DTS using DTS component weights in Table 8.A.1-3 of the DTS Topical Safety Analysis Report (DOE 1996). The total weight of the DTS is estimated to be about 2,300,000 kg (5,000,000 lb), nearly all of which is reinforced concrete. This corresponds to about 860 m³ (1,130 yd³) of nonradioactive waste.

Routine maintenance, fuel repackaging, and construction and operation of the DTS and replacement of the DTS and ISFSI are expected to generate nonradioactive waste that would be handled in accordance with regulatory requirements and disposed of at an appropriately permitted disposal facility. Although a large amount of nonradioactive nonhazardous waste would be generated by the removal of the storage modules, storage pads and DTS

(approximately 22,000 m³ [29,000 yd³]), it would still be less than the amount of waste generated during reactor decommissioning (which NRC already determined would have a SMALL impact), and it would not likely have a noticeable impact on local or regional landfill capacity and operations. Therefore, the NRC determines that the environmental impact from the management and disposal of nonradioactive waste would also be SMALL during long-term storage.

4.15.3 Indefinite Storage

This section evaluates the potential environmental impacts from the management and disposal of LLW, mixed waste, and nonradioactive waste from the indefinite at-reactor storage of spent fuel. The waste-generating activities during this timeframe include the same activities discussed in for long-term storage but with the activities occurring every 100 years.

4.15.3.1 Low-Level Radioactive Waste

The activities associated with the management and disposal of LLW from indefinite at-reactor storage of spent fuel would be similar to those described for long-term storage. As stated in Section 1.8.3, it is expected that sufficient LLW disposal capacity will be made available when needed. Similar to long-term storage, the NRC concludes the management and disposal of LLW could result in SMALL environmental impacts during indefinite storage of spent fuel.

4.15.3.2 Mixed Waste

The activities associated with managing and disposing of mixed waste from the indefinite at-reactor storage of spent fuel after the licensed life for operations will be similar to those discussed for long-term storage. Because of the relatively small quantity of mixed waste generated from indefinite storage and licensee adherence to proper management and disposal regulations, the NRC concludes that the indefinite management of mixed wastes resulting from at-reactor storage of spent fuel would result in SMALL impacts.

4.15.3.3 Nonradioactive Waste

Although the activities associated with managing and disposing of nonradioactive waste from indefinite at-reactor storage will be similar to those discussed for long-term storage, the amount of nonradioactive waste being generated is difficult to accurately estimate over an indefinite timeframe. Therefore, the NRC concludes the management and disposal of nonradioactive waste could result in SMALL to MODERATE impacts, due to nonradioactive nonhazardous waste disposal capacity.

4.16 Transportation

This section describes potential transportation impacts caused by the continued at-reactor storage of spent fuel in spent fuel pools and ISFSIs.

The potential impacts from transportation activities include fugitive dust emissions, increased traffic on local roads, worker and public exposure to radiation, and accident risks. The potential impacts from transportation of spent fuel to a repository or to an away-from-reactor storage facility are not evaluated in this section. Activities and impacts associated with transportation of spent fuel to a repository would occur after continued storage and are addressed as cumulative impacts in Chapter 6. The transportation activities to move spent fuel to an away-from-reactor ISFSI during continued storage are addressed in Chapter 5. Air emissions are evaluated in Section 4.4. The generic analysis in this GEIS is supported by a survey of recent site-specific analyses that were completed by the NRC for new reactors. This transportation analysis considers the impacts of transportation activities during continued storage on the affected environment beyond the site boundary. The environmental impacts evaluated include the nonradiological impacts on regional traffic and accidents from worker commuting, supply shipments, and waste shipments and the public and worker radiological safety impacts from shipments of LLW generated by continued storage activities.

4.16.1 Short-Term Storage

Impacts on traffic from workers commuting to and from the power plant site during the short-term storage timeframe depend on the size of the workforce, the capacity of the local road network, traffic patterns, and the availability of alternate commuting routes to and from the facility. While workforce levels are expected to vary among continued storage facilities (including ISFSIs and spent fuel pools), the limited nature of storage operations relative to power plant operations and the low reported and estimated storage workforce size indicate that the workforce needed to support short-term storage would be much smaller than the power plant workforce. For example, an operational full-time workforce of fewer than 20 workers has been documented for wet storage (safe storage mode) at the GEH Morris ISFSI (NRC 2004c) and a 200-person workforce has been estimated for dry cask ISFSI fuel-transfer and loading operations at the Fort St. Vrain facility (NRC 1991d). For comparison, the operational workforce at nuclear power plants ranges from 600 to 2,400 permanent personnel (NRC 2013a) with an additional 1,000 or more temporary workers needed to support refueling operations (NRC 2011c). The environmental impact on traffic from renewal of operations of nuclear reactors was evaluated generically in the License Renewal GEIS (NRC 2013a), which concluded the impacts on traffic from commuting workers would be SMALL. Because at-reactor ISFSI and spent fuel pool operations represent a small proportion of the operations at any reactor site, the NRC concludes the traffic impacts of continuing the storage activities during the short-term timeframe would continue to be a fraction of the small traffic impacts realized during the period of reactor operations.

The operation of the at-reactor ISFSI and spent fuel pool would generate a small amount of LLW (e.g., used personal protection equipment and wastes related to pool-to-cask transfer activities) relative to power plant operations that would result in infrequent waste shipments to a licensed disposal facility. The Atomic Energy Commission (AEC 1972) estimated the annual amount of LLW generated from a typical 1,100-MW(e) operating light water reactor was 108 m³ (141 yd³), resulting in as many as 70 shipments of waste per year, assuming 0.05 m³ (1.8 ft³) per drum and 30 drums per truck. More recent estimates of annual LLW generated by power plants with higher power ratings are comparable (NRC 2011d) or as much as four times higher (NRC 2013d) than the previously reported 108 m³ (141 yd³) value but would represent, on average, less than one shipment per day. The small and infrequent number of shipments and compliance with NRC and U.S. Department of Transportation (DOT) packaging and transportation regulations would limit potential worker and public radiological and nonradiological impacts from these waste shipments. The radiological impacts on the public and workers of LLW shipments from a reactor have been previously evaluated by the NRC.

A generic impact determination in Table S-4 in 10 CFR 51.52 and supporting analysis (AEC 1972) conclude that the environmental impacts of the transportation of fuel and waste to and from a light water reactor under normal operations of transport and from accidents during transport would be SMALL. Subsequent analysis of LLW transportation impacts in *Final Environmental Statement on Transportation of Radioactive Material by Air and Other Modes* (NRC 1977) concluded transportation impacts are small. Additional site-specific analyses of transportation impacts for power plants that did not meet the conditions of 10 CFR 51.52 also concluded the transportation radiological impacts would be SMALL (NRC 2006b,c; 2008b; 2011a,d-f; 2013a). Because LLW waste-generating activities for continued storage would be a fraction of total power plant LLW-generating activities, the short-term storage LLW waste shipments would also result in a small fraction of the impacts realized for waste shipment during the period of reactor operations.

Based on the preceding analysis that describes the low volume of traffic and shipping activities associated with the continued storage of spent fuel in at-reactor ISFSIs and spent fuel pools, the NRC concludes the impacts on traffic and public and worker radiological and nonradiological safety from transportation activities would be SMALL during the short-term storage timeframe.

4.16.2 Long-Term Storage

As discussed in Section 1.8, the NRC assumes that the spent fuel would need to be repackaged during this timeframe, and that the ISFSI would be replaced. To facilitate the repackaging of the spent fuel, the NRC assumes that a DTS would be constructed.

The construction of a DTS would require a small temporary workforce relative to the power plant workforce. Because a DTS has not been constructed at any power plant site and construction information is limited, the NRC considered a previously reviewed proposal to construct a spent

Environmental Impacts of At-Reactor Continued Storage of Spent Fuel

fuel-transfer facility at the Idaho National Laboratory (NRC 2004a) that estimated a construction workforce of 250 workers for 2 years. Because the proposed Idaho transfer facility is larger (3.2 ha [8.0 ac], NRC 2004a) than the assumed DTS (0.04 ha [0.1 ac], Section 2.2.2.1), the Idaho facility bounds the impacts of constructing a DTS. For comparison, the operational workforce at nuclear power plants ranges from 600 to 2,400 permanent personnel (NRC 2013a) with an additional 1,000 or more temporary workers needed to support refueling operations (NRC 2011c). Based on this information, the NRC concludes that worker commuting traffic impacts associated with construction of a DTS during the long-term storage timeframe would be a small fraction of the power plant operations traffic impacts (described in Section 4.16.1 as small) and therefore the DTS construction traffic would also be small. Operation of the DTS would involve fewer workers than the construction workforce and therefore the commuting traffic impacts during the DTS operations period would also be minor. The remainder of activities during the long-term storage timeframe would be similar to activities and impacts, as evaluated in Section 4.16.1 (i.e., workers commuting and a small number of LLW shipments), and therefore transportation impacts would continue to be small.

The operation of the DTS would involve shipment of materials and generate a small amount of LLW (e.g., used canisters, decontamination swabs, air filters, and used personal protection equipment) (DOE 1996) that would result in infrequent waste shipments to a licensed disposal facility. Supply and waste shipments would be infrequent because transfer activities would occur over a long period of time. The small and infrequent number of LLW shipments and compliance with NRC and DOT packaging and transportation regulations would limit potential worker and public radiological and nonradiological impacts from waste shipments.

Continued repackaging activities and the replacement of the ISFSIs and DTSs would generate additional LLW and nonradiological waste that would need to be shipped offsite for disposal. Section 4.15.2.1 provides an estimate of 480 m³ (630 yd³) of LLW from the repackaging of canisters at a proposed ISFSI and replacement of the ISFSI and DTS. Because repackaging and replacement would occur as needed during the long-term storage timeframe, the LLW shipments would occur infrequently. Repackaging and replacement would generate about 22,000 m³ (29,000 yd³) of nonhazardous waste (Section 4.15.2.3). Assuming the nonhazardous waste from replacement is shipped in roll-off containers with a capacity of 15 m³ (20 yd³), the total number of truck shipments estimated is 1,450. If replacement were phased over a 5-year period, and shipping occurred 5 days per week, about one shipment per day would be needed. The activities would not significantly increase the magnitude of traffic generated by continued storage occurring each year.

The remainder of activities during the long-term storage timeframe would be similar to the activities and impacts evaluated in Section 4.16.1 (i.e., workers commuting and a small number of LLW shipments).

Due to the small workforce requirements for continued storage and aging management activities (relative to the power plant workforce) and the low frequency of supply shipments and shipments of LLW from DTS and ISFSI operations and replacement activities, the NRC concludes that impacts on traffic and public and worker radiological and nonradiological safety during the long-term storage timeframe would each be SMALL.

4.16.3 Indefinite Storage

Assuming no repository becomes available, spent fuel would be stored indefinitely in at-reactor ISFSIs. Annual transportation activities and associated environmental impacts would be similar to those analyzed for long-term storage operations and DTS construction and operations in Section 4.16.2, including continued aging management, repackaging, and replacement activities. In addition, because the impact analysis pertains to continued storage, the maximum inventory of spent fuel in storage at any reactor site would be the same as that evaluated in Section 4.16.1.

Because the NRC concluded in Section 4.16.2 that transportation impacts for continued storage and aging management activities would be SMALL, and no significant changes to the annual magnitude of traffic or waste shipments were identified in the preceding analysis of transportation activities assuming indefinite at-reactor storage, the NRC concludes that the transportation impacts during the indefinite storage timeframe would continue to be SMALL.

4.17 Public and Occupational Health

This section describes potential impacts on public and occupational health caused by the continued storage of spent fuel in spent fuel pools and at-reactor ISFSIs.

For the purposes of assessing radiological impacts, impacts are considered to be SMALL if releases and doses do not exceed dose standards in the NRC's regulations. This definition of SMALL applies to occupational doses as well as to doses to individual members of the public.

Transportation-related public and occupational health impacts are addressed in Section 4.16.

4.17.1 Short-Term Storage

Continued storage of spent fuel in spent fuel pools and ISFSIs is expected to continue in the same manner as during the licensed life for operation of a reactor. The License Renewal GEIS (NRC 2013a) describes a number of specific activities related to continued normal plant operations that result in impacts on public and occupational health. These include normal plant operation for power generation, the storage of spent fuel in fuel pools and ISFSIs, normal refueling, and other outages that include steam generator replacements. Overall, data and analyses presented in the License Renewal GEIS (NRC 2013a) provide ample evidence that

Environmental Impacts of At-Reactor Continued Storage of Spent Fuel

public and occupational doses at all commercial power plants are far below the dose limits in 10 CFR Part 20 and that the continuing efforts to maintain doses at as low as is reasonably achievable levels have been successful. Therefore, because continued storage represents a fraction of the activities occurring during reactor operations, the NRC expects that the public and occupational doses would continue to remain below the regulatory dose limits.

Spent fuel pool leaks can result in environmental impacts. As discussed in Section 4.8.1.1 and Appendix E, in the event that a leak from a spent fuel pool goes undetected and the resulting groundwater plume reaches the offsite environment, it is possible that the leak could be of sufficient magnitude and duration to contaminate a groundwater source above a regulatory limit (i.e., a maximum contaminant level for one or more radionuclides) and that public health impacts could be noticeable, but not destabilizing in such circumstances. As discussed in Appendix E, factors such as spent fuel pool design (stainless-steel liners and leakage-collection systems) and operational controls (monitoring and surveillance of spent fuel pool water levels), onsite and offsite ground water monitoring, make it unlikely that a leak of sufficient quantity and duration could occur without detection. In addition, should a spent fuel pool leak occur, the physical processes associated with radionuclide transport and hydrologic characteristics typical at spent fuel pool locations make it improbable that water leaked from the spent fuel pool would migrate offsite. Therefore, based on the low probability of a leak affecting offsite groundwater sources, the NRC concludes that impacts on public health resulting from a spent fuel pool leak during short-term timeframe would be SMALL.

The data presented in NUREG-0713, *Occupational Radiation Exposure at Commercial Nuclear Power Reactors and Other Facilities 2010* (NRC 2012b), as well as a number of ISFSI license renewal EAs (e.g., the Surry ISFSI [NRC 2005c] and Calvert Cliffs ISFSI [NRC 2012a]), provide ample evidence that the public and occupational radiological health impacts from the continued storage of spent fuel are a small fraction of the doses and impacts presented in the License Renewal GEIS (NRC 2013a) that include reactor operations. For example, NUREG-0713 (NRC 2012b) provides occupational exposure reporting from facilities that no longer have operating reactors, such as the Big Rock Point and Trojan ISFSIs. Both of these facilities had no measurable occupational exposure in the 2010 reporting period. The GEH Morris facility is a spent-fuel-pool-only ISFSI and has never had an operating reactor onsite. Its 2010 annual report indicates an average measured total effective dose equivalent of 0.34 mSv (34 mrem) in relation to the 10 CFR Part 20 occupational dose limit of 50 mSv (5,000 mrem).

The analyses presented in the License Renewal GEIS (NRC 2013a) and a number of ISFSI license renewal EAs (e.g., the Surry ISFSI [NRC 2005c] and Calvert Cliffs ISFSI [NRC 2012a]) provide evidence that annual public and occupational doses would be maintained below the annual dose limits established by 10 CFR Part 72 for the public and 10 CFR Part 20 for occupational personnel. In addition, a licensed storage facility would be required to maintain an as low as is reasonably achievable program, which would likely result in doses lower than those described in the License Renewal GEIS (NRC 2013a).

Nonradiological risks to occupational health and safety would include exposure to industrial hazards and hazardous materials. Industrial hazards are those typical of other industrial facility construction and operating hazards and include exposure to chemicals and accidents ranging from minor cuts to industrial machinery accidents. Preventative maintenance activities are conducted in accordance with Occupational Safety and Health Administration requirements and are infrequent and minor. Therefore, nonradiological occupational health impacts are considered to be minimal.

The NRC concludes that the impacts on public and occupational health due to continued storage of spent fuel would be SMALL during the short-term storage timeframe.

4.17.2 Long-Term Storage

In addition to the impacts considered above for short-term continued storage in an ISFSI, the NRC assumes that a DTS is constructed during the long-term storage timeframe. Risks to occupational health and safety during construction of the DTS would include exposure to industrial hazards, hazardous materials, and radioactive materials. Industrial hazards are those typical of other industrial facility construction and operating hazards and include exposure to chemicals and accidents ranging from minor cuts to industrial machinery accidents. Because construction activities are conducted in accordance with Occupational Safety and Health Administration requirements, nonradiological occupational health impacts are considered to be minor.

Once constructed, operation of the DTS would be very similar to the operations conducted at current reactor plant sites with licensed ISFSIs where spent fuel is loaded into dry storage cask systems and placed on an ISFSI pad. Analyses of ISFSI operations have been conducted in numerous EAs such as those for the Calvert Cliffs (NRC 2012a) and Oconee Nuclear Station (NRC 2009b) ISFSI renewals. These analyses and REMP reports provide ample evidence that public and occupational doses are being maintained well below the dose limits established by 10 CFR Part 72 for the public and 10 CFR Part 20 for occupational personnel. In addition, all NRC-licensed facilities are also required to operate using an as low as is reasonably achievable program to ensure radiation doses are maintained as low as is reasonably achievable.

Based on the reasons provided above, the NRC concludes that the impacts on public and occupational health during long-term storage would be SMALL.

4.17.3 Indefinite Storage

The public and occupational health impacts of continuing to store spent fuel without a repository would be similar to those described for long-term storage. The activities and associated human health impacts would remain the same. The main difference is that these activities would occur repeatedly.

The no repository scenario was analyzed in detail in the Yucca Mountain final EIS (FEIS) (DOE 2002) as the no-action alternative. The Yucca Mountain FEIS analyses looked at the short- and long-term impacts of continued storage of spent fuel and high-level radioactive waste at 72 commercial and 5 DOE sites for 10,000 years. The Yucca Mountain FEIS, in the analysis of the no-action alternative, assumes all commercial spent fuel would eventually be stored in dry configurations in ISFSIs at the existing locations. Detailed analyses were provided to demonstrate the expectation that maintenance, repairs, repackaging, operation, and construction at the storage facilities would be conducted in accordance with the requirements of the Occupational Safety and Health Administration and 10 CFR Parts 20 and 72, as discussed in the sections above. In addition, administrative controls and design features would minimize worker nonradioactive and radioactive exposures. The Yucca Mountain FEIS analyses and the discussion provided in Section 4.17.2 support the conclusion that public and occupational radiological health impacts could be maintained within the public and occupational dose limits of 10 CFR Parts 72 and 20. Therefore, the NRC concludes that the impacts on public and occupational health due to the indefinite storage of spent fuel in at-reactor ISFSIs would be SMALL.

4.18 Environmental Impacts of Postulated Accidents

This section describes the environmental impacts of postulated accidents involving the continued storage of spent fuel.

During continued storage, numerous features combine to reduce the risk associated with accidents involving spent fuel storage in spent fuel pools and ISFSIs. Safety features in the design, construction, and operation of nuclear power plants and ISFSIs, which are the first line of defense, are imposed to prevent the release of radioactive materials. Additional measures are designed to mitigate the consequences of failures in the first line of defense. These include the NRC's reactor site criteria in 10 CFR Part 100, "Reactor Site Criteria," which require the site to have certain characteristics that reduce the risk to the public and the potential impacts of an accident, and emergency preparedness plans and protective action measures for the site and environs. All these safety features, measures, and plans make up the defense-in-depth philosophy used by the NRC to protect the health and safety of the public and the environment (NRC 2013d).

Design Basis Events, Design Basis Accidents, and Severe Accidents

Design basis events are conditions of normal operation, design basis accidents, external events, and natural phenomena, for which the plant must be designed to ensure the capability to prevent or mitigate the consequences of accidents that could result in potential offsite exposures (NRC 2007b).

Design basis accidents are postulated accidents that are used to set design criteria and limits for the design and sizing of safety-related systems and components (NRC 2007b).

Severe accidents, or beyond-design-basis accidents, are accidents that may challenge safety systems at a level much higher than expected.

Environmental Impacts of At-Reactor Continued Storage of Spent Fuel

Consistent with the defense-in-depth philosophy, this section describes design basis events for which the strategy is to prevent or mitigate the consequences of accidents that could result in potential offsite doses. For some design basis events, such as tornadoes, this section describes how the storage facility is designed and built to withstand the event without loss of systems, structures, and components necessary to ensure public health and safety. In these cases, the environmental impacts are small because no release of radioactive material would occur. Other design basis events, such as spent fuel-handling accidents, are design basis accidents that licensees must assume could occur. In these cases, licensees must show how engineered safety features in the facility mitigate a postulated release of radioactive material. The environmental impacts of design basis accidents are small because all licensees must maintain engineered safety features that ensure that the NRC dose limits for these accidents are met. The basis for impact determinations for design basis events (i.e., whether the accident is prevented or mitigated) is described for each type of design basis event presented in this section.

Regulations governing accidents that must be addressed by nuclear power facilities, both operating and shutdown, are found in 10 CFR Parts 50, 52, and 100. The environmental impacts of design basis events, including those associated with the spent fuel pool, are evaluated during the initial licensing process. The ability of the plant to withstand these accidents is demonstrated to be acceptable before issuance of the operating license. The results of these evaluations are found in license documentation, such as the NRC's safety evaluation report, the final environmental impact statement, and in the licensee's Final Safety Analysis Report (FSAR) or equivalent. The licensee is required to maintain the acceptable design and performance criteria throughout the life of the plant, including during continued storage (NRC 2002b).

The consequences of a severe (or beyond-design-basis) accident, if one occurs, could be significant and destabilizing. The impact determinations for these accidents, however, are made with consideration of the low probability of these events. The environmental impact determination with respect to severe accidents, therefore, is based on the risk, which the NRC defines as the product of the probability and the consequences of an accident. This means that a high-consequence low-probability event, like a severe accident, could therefore result in a small impact determination, if the risk is sufficiently low.

This section of the GEIS follows a different format than the rest of the document. Because the accident risks for spent fuel pool storage only apply during the short-term timeframe and the accident risks for dry cask storage are substantially the same across the three timeframes, the GEIS presents the various accident types only once. The three storage timeframes (short-term, long-term, and indefinite, as described in Chapter 1) apply as follows:

- During short-term storage, both design basis and severe accidents are postulated for spent fuel stored in the onsite spent fuel pool and at-reactor ISFSI.

Environmental Impacts of At-Reactor Continued Storage of Spent Fuel

- For long-term and indefinite storage, the NRC assumes that the spent fuel is moved from the spent fuel pool to an at-reactor ISFSI. Therefore, only accidents involving an at-reactor ISFSI are possible during the long-term and indefinite storage timeframes.

4.18.1 Design Basis Events

During the continued storage of spent fuel, licensees maintain systems, structures, and components that ensure public health and safety. The hazards that are considered in the design and operation of storage facilities include failure of facility systems, structures, and components; man-made hazards, such as nearby military, industrial, and transportation facilities; and natural phenomena, such as earthquakes and floods.

4.18.1.1 Design Basis Events in Spent Fuel Pools

A number of postulated design basis events are considered in the design of spent fuel pools. Design features of spent fuel pools ensure prevention of inadvertent criticality and also ensure that the pool is designed to withstand hazards that could result in a significant loss of water. This section provides brief summaries of accidents involving spent fuel storage operations during the short-term storage timeframe.

Criticality Accidents

The presence of fissile nuclides in spent fuel requires that controls must be in place to prevent inadvertent nuclear chain reaction, or criticality, while spent fuel is in storage. NRC regulations in 10 CFR 50.68, "Criticality Accident Requirements," and General Design Criterion 62, "Prevention of Criticality in Fuel Storage and Handling," of Appendix A, "General Design Criteria for Nuclear Power Plants," to 10 CFR Part 50 require that subcriticality in spent fuel pools be maintained. To comply with these requirements, licensees design and implement controls based on spent fuel pool nuclear criticality safety analyses. These controls include the use of neutron-absorbing material in spent fuel pool storage racks. The neutron-absorbing material's physical properties, including its dimensions and boron-10 areal density, help maintain subcriticality. These nuclear criticality safety analyses are usually documented in the licensee's FSAR and are the basis for demonstrating compliance with plant technical specifications, NRC regulations, and demonstrating adequate subcriticality for both normal operating conditions and design basis accidents.

Many licensees use integrated defense-in-depth design features to reduce the chance of a criticality accident if the neutron-absorbing material degrades. For example, some PWRs have received approval to take credit for the soluble boron in the spent fuel pool.

Licenses are required to demonstrate that some margin to criticality is maintained for a variety of abnormal conditions, including fuel-handling accidents involving a dropped fuel assembly. The environmental impacts are small, therefore, because criticality accidents in spent fuel pools are prevented.

Nearby Military, Industrial, and Transportation Facilities

Nuclear power plant licensees are required to assess hazards from nearby military, industrial, and transportation facilities to ensure that potential hazards in the site vicinity have been considered in the plant's design bases. If hazards are identified, such as overpressure from explosions from nearby industrial facilities, licensees are required to show that the probability is sufficiently low (an order of magnitude of 10^{-7} /yr or less) or that radiological dose criteria in 10 CFR 50.34(a)(1) are met. Since either the probability or the consequences must be acceptably small, the environmental risk of spent fuel pool releases caused by hazards from nearby military, industrial, and transportation facilities is small.

Postulated Fuel Assembly or Cask Drop

In accordance with NRC regulations in 10 CFR 50.34 and 52.79, a licensee must show that a plant site and mitigating engineered safety features are acceptable with respect to the consequences of postulated spent fuel cask drop accidents. Improper operation of the handling equipment (e.g., cranes), poor rigging practices, and equipment failures can lead to a drop of a cask or a fuel assembly into a spent fuel pool. Generally, the handling equipment is designed and constructed in accordance with the ASME NOG-1 Standard (ASME 2010) to be certified as single-failure-proof (any single failure will not drop the load).

A heavy load (e.g., cask) drop into the pool or onto the pool wall could affect the structural integrity of the fuel pool. An unlikely drop of a fuel assembly may cause mechanical damage to the fuel. Because a relatively small amount of mechanical damage to the fuel could cause significant radiation doses to facility personnel and releases to the environment, the spent fuel pool facility has radiation monitors and also provides confinement of radioactive material released from damaged fuel. The spent fuel pool facility is a controlled leakage building with a safety-grade filtration system in its ventilation system. This filtration system provides the necessary confinement to limit offsite dose consequences (NRC 2001).

The licensee provides the necessary plant description and analyses in its FSAR to demonstrate the safety of the spent fuel pool during the initial license application of the reactor to the NRC. The licensee also revises the plant description and accident analyses in the FSAR, as needed. As part of its continuing regulatory oversight of the plant, the NRC reviews the plant description and accident analyses during the initial licensing proceedings, as well as any subsequent revision to the FSAR.

Environmental Impacts of At-Reactor Continued Storage of Spent Fuel

In general, the NRC's accident dose review criterion for fuel-handling accidents at most plants, including cask drops, is 62.5 mSv (6.25 rem) total effective dose equivalent to an offsite individual (NRC 2000). This dose criterion must be met regardless of the probability of the design basis event.

Since the postulated fuel assembly or cask drop is among the design basis accidents analyzed by licensees, and licensees must show that radiation dose limits in 10 CFR 50.34(a)(1) will be met, the environmental consequences associated with this type of design basis accident during continued storage are small.

Natural Phenomena Hazards

Appendix A, "General Design Criteria for Nuclear Power Plants," to 10 CFR Part 50 requires that structures, systems, and components that are important to safety be designed to withstand the effects of natural phenomena, such as earthquakes, tornadoes, hurricanes, floods, tsunamis and seiches, without loss of capability to perform their safety functions. General Design Criterion 2 (of Appendix A, "General Design Criteria for Nuclear Power Plants," to 10 CFR Part 50) also requires that the design bases for these structures, systems, and components reflect (1) appropriate consideration of the most severe of the natural phenomena that have been historically reported for the site and surrounding area, with sufficient margin for the limited accuracy, quantity, and period of time in which the historical data have been accumulated; (2) appropriate combinations of the effects of normal and accident conditions with the effects of the natural phenomena; and (3) the importance of the safety functions to be performed.

General Design Criterion 4, "Environmental and Dynamic Effects Design Bases," also applies to spent fuel pool design as it relates to information on tornadoes that could generate missiles.

NRC siting regulations in 10 CFR Part 100, "Reactor Site Criteria," also require applicants to consider, among other things, physical characteristics of sites that are necessary for safety analysis or that may have an impact upon plant design (such as maximum probable wind speed and precipitation). Licensees and applicants are required to identify and characterize the physical characteristics of the site, so that they may be taken into consideration when determining the acceptability of the site. Appendix A of 10 CFR Part 100, "Seismic and Geologic Siting Criteria for Nuclear Power Plants," describes the nature of investigations required to obtain geologic and seismic data necessary to determine site suitability and to provide reasonable assurance that a nuclear power plant can be constructed and operated at a proposed site without undue risk to the health and safety of the public. Appendix A describes the procedures for determining the quantitative vibratory ground motion design basis at a site due to earthquakes and describes information needed to determine whether and to what extent a nuclear power plant needs to be designed to withstand the effects of surface faulting.

Environmental Impacts of At-Reactor Continued Storage of Spent Fuel

Each applicant for a construction permit for a power plant is required to investigate the site for all seismic and geological factors that may affect the design and operation of the plant to provide reasonable assurance that the plant can be constructed and operated without undue risk to health and safety of the public. These siting criteria also provide reasonable assurance that the spent fuel pool can be operated safely during the short-term storage timeframe.

Earthquakes

The NRC requires licensees to design, operate, and maintain safety-significant structures, systems, and components, including spent fuel pools, to withstand the effects of earthquakes and to maintain the capability to perform their intended safety functions. The agency ensures these requirements are satisfied through the licensing, reactor oversight, and enforcement processes (NRC 2011e). In 2005, the NRC began to assess the safety implications of increased nuclear power plant earthquake hazards identified for the central and eastern United States. The NRC identified the issue as Generic Issue 199 (GI-199) and completed a limited scope screening analysis in December 2007, which culminated in the issuance of a safety/risk assessment in August 2010 (NRC 2010). In the 2010 assessment, the NRC chose seismic core damage frequency as the appropriate risk metric to changes in the seismic hazard. For each power plant, the NRC estimated the change in seismic core damage frequency as a result of the updated seismic hazard. This analysis confirmed that operating nuclear power plants remain safe with no need for immediate action. The NRC took regulatory action after the March 2011 earthquake and tsunami in Japan. In March 2012, the NRC issued a request for information to all U.S. nuclear power plants asking licensees to (1) conduct walkdowns of their plants, including the spent fuel pools, to identify and address plant-specific vulnerabilities (through their corrective action programs) and verify the adequacies of monitoring and maintenance procedures; and (2) reevaluate the seismic hazards at the plants against present-day NRC requirements and guidance. These assessments may make use of new consensus seismic hazard estimates for the power plants in the central and eastern United States developed by the DOE, EPRI, and NRC (NRC 2012c). The NRC has issued guidance to complete these walkdowns and reevaluations and will take additional regulatory action, as necessary, in response to the findings.

Floods

As with earthquakes and other natural phenomena, the NRC requires licensees to design, operate, and maintain safety-significant structures, systems, and components, including the spent fuel pool, to withstand the effects of floods and to maintain the capability to perform their intended safety functions. The analysis to meet this requirement involves estimating a design basis flood, which is defined as a flood caused by one or an appropriate combination of several hydrometeorological, geoseismic, or structural-failure phenomena, which results in the most severe hazards to safety-significant structures, systems, and components (NRC 1976; Prasad et al. 2011). Based in part on the plant physical siting location and characteristics, the design

Environmental Impacts of At-Reactors Continued Storage of Spent Fuel

basis flood can include flooding on the site caused by local intense precipitation or local probable maximum precipitation, stream flooding, storm surges, seiches, tsunamis, seismically induced dam failures or breaches, flooding caused by landslides, the effects of ice formation in waterbodies, or some combination of these phenomena (NRC 2013a).

All safety-significant structures, systems, and components are required to be protected against the design basis flood by siting them above the highest flood water-surface elevation or providing adequate flooding protection. The NRC requires that this protection be achieved by using a dry site concept, external barriers, or incorporated barriers (NRC 1976). The dry site concept involves constructing the nuclear power plant above the design basis flood water-surface elevation using either the natural terrain or engineered fill. External barriers are engineered solutions that can include levees, seawalls or floodwalls, bulkheads, revetments, or breakwaters. Incorporated barriers are also engineered solutions that involve specially designed walls or penetration closures.

Given these physical siting and engineered factors, the environmental risk of spent fuel pool releases caused by design basis floods is small.

The NRC also took regulatory action after the March 2011 earthquake and tsunami at the Fukushima Dai-ichi nuclear power plant. In March 2012, the NRC issued a request for information to all U.S. nuclear power plants asking licensees to (1) conduct plant walkdowns (visual inspections) to identify and address plant-specific vulnerabilities (through their corrective action programs) and verify the adequacies of monitoring and maintenance procedures; and (2) reevaluate the flooding hazards at the plants against present-day NRC requirements and guidance to ensure that the plant is designed, operated, and maintained in such a manner that safety-significant structures, systems, and components, including the spent fuel pool, are able to withstand the effects of floods (NRC 2012d). The NRC has issued guidance to complete these walkdowns and reevaluations and will take additional regulatory action, as necessary, in response to the findings. The information collected in response to the request for information will also be applicable to resolution of GI-204, *Flooding of Nuclear Power Plant Sites Following Upstream Dam Failures* (NRC 2013e).

High Winds (Tornadoes and Hurricanes)

The NRC requires licensees to consider both sustained straight winds, such as those caused by hurricanes, and brief high rotational and translational winds that are caused by tornadoes in the design of safety-related structures. Because tornado wind speeds are generally higher than hurricane wind speeds, tornado winds tend to be the limiting consideration in design. The NRC's definition of a design basis tornado, originally published in 1974 in Regulatory Guide 1.76, describes design basis tornado characteristics in each of three regions of the United States (NRC 1974). The design basis tornado characteristics east of the eastern foothills of the Rocky Mountains included a maximum wind speed of 580 km/hr (360 mph).

Environmental Impacts of At-Reactor Continued Storage of Spent Fuel

The Pacific coastal region and Rocky Mountain region had design basis tornado characteristics that include a maximum wind speed of 480 km/hr (300 mph) and 390 km/hr (240 mph), respectively. Operating nuclear power plants in these regions that meet this guidance are designed to withstand these wind speeds. By comparison, few hurricanes have achieved wind speeds of 310 km/hr (190 mph) (Bender et al. 2010).

In 2007, the NRC updated its design basis tornado definition such that a maximum wind speed of 370 km/hr (230 mph) is appropriate for tornadoes for the central portion of the United States; a maximum wind speed of 320 km/hr (200 mph) is appropriate for a large region of the United States along the east coast, the northern border, and western Great Plains; and a maximum wind speed of 260 km/hr (160 mph) is appropriate for the western United States (NRC 2007c). Because design basis tornado windspeeds were decreased as a result of the analysis performed to update Regulatory Guide 1.76, it was no longer clear that the revised tornado design basis windspeeds would bound design basis hurricane windspeeds in all areas of the United States. As a result, in 2011 the NRC published new guidance for design basis hurricane and hurricane missiles for nuclear power plants (NRC 2011f). This guidance describes windspeeds and other hurricane characteristics acceptable to the staff for defining a design basis hurricane for new nuclear power plants. For example, under this new guidance, which would apply to new reactors, design basis 3-second gust windspeeds along the eastern Florida coast range from 370 km/hr (230 mph) to 470 km/hr (290 mph).

Given the required design bases for nuclear power plants, including spent fuel pool structures, only severe winds would cause damage to a PWR or a BWR spent fuel pool. Generally, the safety-related structures of a spent fuel pool facility (e.g., the pool wall) are designed to withstand the design basis wind and missiles; however, the facility superstructure and other systems may not be classified as safety-related and may sustain some damage from wind and wind-generated missiles. In 2001, the NRC estimated the annual frequency of catastrophic pool failure from an impact of a tornado-generated missile given a strike of a tornado having at least F4 intensity to be less than 10^{-9} (NRC 2001). The extremely low probability of tornado-induced accidents ensures that the environmental risk of spent fuel pool releases caused by design basis high winds is small.

Climate Change

As described above, NRC regulations in 10 CFR Parts 50, 52, and 100 require that spent fuel pools be designed to withstand the effects of natural phenomena. Climate change can influence the frequency and intensity of some natural phenomena. This section of the GEIS addresses the environmental impacts from climate change on the continued storage of spent fuel in spent fuel pools. The NRC acknowledges that climate change may have impacts across a wide variety of resource areas including air, water, ecological, and human health. The U.S. Global Change Research Program (GCRP) describes these potential impacts in the report *Climate Change Impacts in the United States* (GCRP 2014). However, in this GEIS, the

Environmental Impacts of At-Reactor Continued Storage of Spent Fuel

discussion of impacts from climate change on the environment will focus on those affecting the continued storage of spent fuel. The contribution of continued storage to greenhouse gas emissions and climate change are addressed in Sections 4.5 and 5.5.

Because spent fuel will only be stored in spent fuel pools during the short-term timeframe, the consideration of climate change impacts for pool storage only needs to address the short-term timeframe. Climate change can lead to an increased intensity and frequency of severe weather events (e.g., flooding, high winds from hurricanes and tornadoes, droughts, and increased temperatures in nearby surface waterbodies used as cooling-water supplies). As described previously in this section, the NRC requires licensees to design, operate, and maintain safety-significant structures, systems, and components to withstand the effects of floods and other natural phenomena and to maintain the capability to perform their intended safety functions. The agency ensures these requirements are satisfied through the licensing, oversight, and enforcement processes. The NRC's oversight authority over the licensed facilities will ensure that minimal impacts of natural hazards would be associated with climate change during short-term continued storage in spent fuel pools. As stated above, potential effects associated with climate change on the safety of spent fuel storage are flooding from storm surges and high winds caused by extreme weather events like hurricanes. Rise in sea level is controlled by complex processes, and it is projected to rise between 0.3 and 1.2 m (1 and 4 ft) by 2100 (GCRP 2014).³ Based on this projected change, no U.S. nuclear power plant (operational or decommissioned) will be underwater solely because of sea level rise before 2100. In addition to sea-level rise, spent fuel facilities may be affected by increased storm surges, erosion, shoreline retreat, and inland flooding. Coastal area impacts may be exacerbated by land subsidence. Section 4.18.2 considers when climate change influences on natural phenomena (e.g., sea-level rise along with storm surge) contribute to flooding levels beyond the design basis. NRC-licensed spent fuel storage facilities are designed to be robust. They are evaluated to ensure that the performance of their safety systems, structures, and components is maintained during flooding events, and they are monitored when in use. The lowest grade above the sea level of concern for an NRC-licensed facility is currently about 4.3 m (14 ft) (75 FR 81037). In the event of climate change-induced sea-level rise, which would occur gradually over long periods of time, the NRC (see, e.g., 10 CFR Part 50, Appendix B, Section XVI, "Corrective Action") requires licensees to implement corrective actions to identify and correct or mitigate conditions adverse to safety. Further, as stated above, following the March 2011 accident at the Fukushima Dai-ichi nuclear power plant in Japan, licensees of operating nuclear power plants are reevaluating flood hazards using present-day regulations and regulatory guidance. When completed, these reevaluations will provide additional assurance that existing plant design bases reflect the current state of knowledge of flood hazards. In addition, the NRC will use the information

³ The 2014 National Climate Assessment (GCRP 2014) also notes that in the context of risk-based analysis, some decision makers may wish to use a wider range of scenarios, from 0.2 m (8 in) to 2 m (6.6 ft) by 2100.

collected to determine whether further regulatory action is needed concerning flood hazard analysis and design basis.

Climate change can also lead to an increase in the frequency of droughts. Increasing temperatures have made droughts more severe and widespread. Trends in droughts vary regionally. Short-term (seasonal or shorter) droughts are expected to intensify in most U.S. regions, while longer-term droughts are expected to intensify in the Southwest, southern Great Plains, and Southeast (GCRP 2014). Except in a few areas where increases in summer precipitation are expected to compensate for drought effects, summer droughts are expected to intensify across the continental United States (GCRP 2014). Droughts can cause increased competition for limited water resources. Although some aspects of spent fuel storage require water, the amount of water needed is minimal and water use for spent fuel storage is not expected to cause water-use conflicts, even under the changed conditions that could be caused by climate change (see Sections 4.7, 4.8, 4.9, 5.7, 5.8, and 5.9).

Summary

The postulated design basis accidents considered in this GEIS for spent fuel pools include hazards from natural phenomena, such as earthquakes, flood, tornadoes, and hurricanes; hazards from activities in the nearby facilities; and fuel-handling-related accidents. In addition, the potential effects of climate change are also considered. Based on the above analysis, the environmental risk of these postulated accidents involving continued storage of spent fuel in pools is SMALL, because all important to safety structures, systems, and components involved with the fuel storage are designed to withstand these design basis accidents without compromising the safety functions. If climate change influences on natural phenomena create conditions adverse to safety, the NRC has sufficient time to require corrective actions to ensure spent fuel storage continues with minimal impacts.

4.18.1.2 Design Basis Events in Dry Cask Storage Systems

Design basis events are considered in the design of dry cask storage systems in accordance with NRC regulations in 10 CFR Part 72, "Licensing Requirements for the Independent Storage of Spent Nuclear Fuel, High-Level Radioactive Waste, and Reactor-Related Greater Than Class C Waste." These requirements are applicable to dry cask storage systems for continued storage of spent fuel at all times, including the period of reactor operations, and all three continued storage timeframes (i.e., short-term, long-term, and indefinite storage).

In the safety analysis reports for specifically licensed dry cask storage facilities, each facility licensee examines four categories of design events as defined in American National Standards Institute (ANSI) standard ANSI/ANS-57.9 (1992), which include normal, off-normal, and accidental events. Design Events I represent those associated with normal operations of an ISFSI. These events are expected to occur regularly or frequently. Examples of normal events

Environmental Impacts of At-Reactor Continued Storage of Spent Fuel

include receipt, inspection, unloading, maintenance, and loading of a transportation package; transfer of loaded storage casks to the storage pads; and handling of radioactive waste generated as part of the operation. The impacts from these events are similar to those of normal operations at the ISFSI.

Design Events II represent those associated with off-normal operations that can be expected to occur with moderate frequency, approximately once per year. These events could result in members of the general public being exposed to additional levels of radiation beyond those associated with normal operations. Examples of these events include loss of external electrical power for a limited duration, off-normal ambient temperatures, a cask drop from less than the design allowable lift height, and off-normal transporter operation. Credible off-normal events or Design Events II rarely result in any occupational or offsite radiological consequences. During normal operations and off-normal conditions, the requirements of 10 CFR Part 20 must be met. In addition, the annual dose equivalent to any individual located beyond the controlled area must not exceed 0.25 mSv (25 mrem) to the whole body, 0.75 mSv (75 mrem) to the thyroid, and 0.25 mSv (25 mrem) to any other organ.

Design Events III represent infrequent events that could be reasonably expected to occur over the lifetime of the dry cask storage facility, while Design Events IV represent extremely unlikely events or design basis accidents that are postulated to occur because they establish the conservative design basis for systems, structures, and components important to safety. Design Events III and IV include more severe events, such as earthquakes, tornadoes and missiles generated by natural phenomena, floods, fire (including wildfires) and explosions, lightning, accidents at nearby sites (facilities), aircraft crashes, canister leakage under hypothetical accident conditions, storage cask drop or tip-over, and loss of shielding. The dose from any credible design basis accident to any individual located at or beyond the nearest boundary of the controlled area may not exceed that specified in 10 CFR 72.106; specifically, the more limiting total effective dose equivalent of 0.05 Sv (5 rem) or the sum of deep dose equivalent to and the committed dose equivalent to any individual organ or tissue (other than eye lens) of 0.05 Sv (50 rem); a lens dose equivalent of 0.15 Sv (15 rem); and a shallow dose equivalent to skin or any extremity of 0.5 Sv (50 rem).

The NRC assumes a DTS, or a facility with equivalent capabilities, will be needed to enable retrieval of spent fuel for inspection or repackaging as the duration and quantity of fuel in dry storage increases. A DTS would provide repackaging capability at all dry storage sites without the need to return to a pool and contingency by enabling repackaging at ISFSI-only sites. A DTS would allow onsite transfer of bare fuel assemblies from a source cask to a receiving cask (Christensen et al. 2000). The source cask can be a storage cask or a transfer cask. Confinement and shielding during fuel-transfer operations are provided by the concrete and steel structure. The facility has several subsystems including one used to transfer the fuel assemblies.

Environmental Impacts of At-Reactor Continued Storage of Spent Fuel

Two accidents considered in the Topical Safety Analysis Report for the reference DTS (DOE 1996) are representative of the types of accidents that could result in environmental impacts. These accidents involve a stuck fuel assembly and a loss-of-confinement event.

A fuel assembly in a reference DTS can become stuck while being retrieved from a cask or while being inserted into a cask for repackaging. Both of these scenarios can increase the dose at the site boundary because of increased time of operation, and they represent the bounding accidents. The design of the fuel-handling machine would have several safety features to make these scenarios unlikely.

Licensees of a reference DTS would be required to incorporate special recovery procedures in the facilities operational plan to free the stuck assembly, including use of special equipment through the penetrations in the wall with full viewing capabilities provided by closed-circuit television cameras. A fuel assembly may be stuck part-way out because a foreign object is between the assembly and the fuel cell or because of protrusions inside the cask. The situation could be detected because loads recorded by the fuel-assembly load cell would be abnormal and appropriate actions could be taken. There would not be any time limit to complete the recovery operations because the assembly would be shielded. A special "recovery" cask may be needed if the assembly is significantly distorted. The dose from these bounding scenarios was estimated to be 0.47 mSv (47 mrem) at a distance of 100 m (330 ft) from the DTS, assuming it would take 2 weeks to free the stuck fuel assembly.

In a loss-of-confinement event, TN-EPRI considered a scenario in which high-efficiency particulate air filters are inoperable while the receiving cask is open and filled with 21 fuel assemblies. The accident impact analysis is based on assuming that volatile radionuclides are released from damaged fuel, including up to 10 percent of the noble gases (except that up to 30 percent of the krypton-85 is released), tritium, and iodine-129. The total dose at 100 m (330 ft) is calculated to be 7.21 mSv (721 mrem).

Because the accident consequences would not exceed the NRC accident dose standard contained in 10 CFR 72.106, the environmental impact of the potential accidents would be SMALL.

Climate Change

The natural hazards that could be affected by climate change which are important to dry cask storage siting and design include flood and high-wind hazards. As described in Section 2.2, dry cask storage occurs during the short-term, long-term, and indefinite storage timeframes. Therefore, the analysis for dry cask storage would extend beyond the 60-year short-term timeframe considered in the spent fuel pool analysis. Projected future conditions include uncertainty.

Environmental Impacts of At-Reactor Continued Storage of Spent Fuel

The amount and rate of future climate change depends on current and future human-caused emissions (GCRP 2014). Quantitative expressions, such as the amount of sea-level rise identified in Section 4.18.1.1, may only extend to the end of the century. To whatever extent climate change alters the magnitude and frequency of natural phenomena during and beyond the short-term storage timeframe, the NRC's oversight authority over the licensed facilities is the mechanism that addresses the impact of natural hazards. Under current NRC regulations applicable to dry cask storage facilities, the NRC requires that the vendor or licensee include design parameters on the ability of the storage casks and spent fuel storage facilities to withstand severe weather conditions such as hurricanes, tornadoes, and floods. NRC-licensed spent fuel storage facilities are designed to be robust. They are evaluated to ensure that performance of their safety systems, structures, and components is maintained in response to natural phenomena hazards. In the event of impacts induced by climate change, such as sea-level rise, which occurs gradually over long periods of time, the NRC regulations (e.g., 10 CFR 72.172, "Corrective action") require licensees to implement corrective actions to identify and correct conditions adverse to safety.

Summary

In summary, the dry storage cask systems and any DTSs are designed to withstand the design basis accidents without losing safety functions. In addition, DTSs will have special recovery procedures in their operation plans to recover from these design basis accidents if they occur. If climate change influences on natural phenomena create conditions adverse to safety, the NRC has sufficient time to require corrective actions to ensure spent fuel storage continues with minimal impacts.

4.18.1.3 Conclusion

All NRC-licensed dry cask storage systems are designed to withstand all postulated design basis accidents (Design Events III and IV) with no loss of the safety functions. Licensees of DTSs will be required to design the facilities so that all safety-related structures, systems, and components can withstand the design basis accidents without compromising safety functions. In addition, the potential effects of climate changes are considered. Based on the assessment, the environmental impact of the design basis accidents is SMALL because safety-related structures, systems, and components are designed to function during and after these accidents.

4.18.2 Severe Accidents

This section describes severe accidents, or beyond-design-basis accidents, which are accidents that may challenge safety systems at a level higher than that for which they were designed, and assesses the environmental impact of severe accidents during continued storage. The probability and consequences of severe accidents are usually considered by the NRC in probabilistic risk assessments in which risk is determined by multiplying the probability of an

event times its consequences. The results of past studies for spent fuel pools and dry cask storage systems are summarized in the following sections.

4.18.2.1 Severe Accidents in Spent Fuel Pools

The NRC examined the risk of severe accidents in spent fuel storage pools in WASH-1400 (NRC 1975). WASH-1400 states that spent fuel pool accidents can arise from either loss of pool cooling, drainage of the pool, or drop of heavy objects into the pool. Subsequently, the NRC developed NUREG-1353 (NRC 1989), which examined several severe accidents that can affect a spent fuel storage pool, namely loss of cooling or makeup water, inadvertent draining of the pool, and structural failure of the pool due to missiles, aircraft crashes, heavy load (shipping cask) drop, and beyond-design-basis earthquakes. NUREG-1738 (NRC 2001) examined spent fuel pool accidents at decommissioning nuclear power plants. In addition to scenarios leading to fuel uncovering in a pool (fuel being uncovered, e.g., because of loss of cooling, loss of offsite power, heavy load drops, and fire), NUREG-1738 also examined the risk from seismic events, aircraft crashes, and tornadoes to a spent fuel pool. Assessments made in these studies are briefly discussed in the following sections.

Internal Events

In previous studies, the NRC considered a number of different types of equipment failure, or internal events that could lead to a severe accident in a spent fuel pool. For example, all spent fuel pools have a spent fuel pool cooling and cleanup system. This safety function of this system is intended to ensure that spent fuel remains cool and covered with water during all storage conditions. In addition to General Design Criterion 2, which is summarized above, pools are required to meet General Design Criterion 61 or equivalent principal design criteria;⁴ General Design Criterion 61 states, among other things, that systems for fuel storage and handling shall be designed with residual heat removal capability to provide reliability and testability that reflects the importance to safety of decay heat, other residual heat removal, and prevention of significant reduction in fuel storage coolant inventory under accident conditions.

In general, this means that spent fuel pool cooling and cleanup systems are designed to satisfy either of two bases: (1) the cooling portion of the system is designed to seismic Category I (Regulatory Guide 1.29) (NRC 2007d), Quality Group C (Regulatory Guide 1.26) guidelines (NRC 2007e); or (2) the following systems are designed to seismic Category I, Quality Group C guidelines and are protected against tornadoes: the fuel pool makeup water system and its source; and the fuel pool building and its ventilation and filtration system. Licensees prevent a significant reduction in spent fuel pool coolant inventory by providing adequate makeup water

⁴ U.S. facilities for which construction permits were issued before 1971 have plant-specific principal design criteria, because the Atomic Energy Commission (NRC predecessor) had yet to develop generic requirements for facility design criteria at that time.

Environmental Impacts of At-Reactor Continued Storage of Spent Fuel

capability and designing the spent fuel pool cooling and cleanup system so that the coolant can neither be drained nor siphoned below a specified level.

In NUREG–1738 (NRC 2001), the NRC concluded that the frequency of spent fuel uncovering resulting from loss of offsite power ranges from 1.1×10^{-7} /yr for power losses caused by severe weather to 2.9×10^{-8} /yr for plant-related and grid-related events. Lack of external power would cause cooling systems to fail, resulting in elevated pool water temperatures and accelerated evaporation of the pool water. In the event of even a long-term loss of normal pool makeup water capability at U.S. power plants, measures that were installed in response to the September 11, 2001 terrorist attacks, plus additional measures that are required as a result of the post-Fukushima March 12, 2012, mitigating strategies order, would ensure additional defense-in-depth protection for cooling of the spent fuel. Therefore, the environmental risk of spent fuel pool releases caused by loss of offsite power is considered to be small.

A discussion of a postulated spent fuel pool fire resulting from loss of pool water, a severe accident in a spent fuel pool, is provided in Appendix F. Appendix F describes the NRC's finding that the probability-weighted consequences of atmospheric releases, fallout onto open bodies of water, and societal and economic impacts of spent fuel pool fires are SMALL.

External Events

In previous studies, the NRC considered how different types of external events, such as tornadoes, aircraft crashes, and seismic events, could lead to a severe accident in a spent fuel pool. Each of these external events was evaluated to determine the frequency of spent fuel uncovering associated with the event. In NUREG–1738 (NRC 2001), the NRC determined that seismic events had higher fuel uncovering frequencies than aircraft crashes and tornadoes. For this reason, the seismic event is used in this GEIS as a representative external event causing a severe accident.

As discussed in Appendix F, numerous NRC studies have concluded that spent fuel pool structures are seismically robust and can withstand loads substantially beyond those for which they are designed (NRC 2001). During an earthquake, the walls and floor of the pool would carry the seismically induced hydrodynamic pressure from the pool water. Structural (floor, liner, or walls) failure could occur in a beyond-design-basis earthquake, if the magnitude of the event is significantly larger than that used in the design. If this occurred, water would rapidly drain out of the pool. Only a small amount of water would remain and the spent fuel would be uncovered and exposed to the air. A beyond-design-basis earthquake would also likely result in the loss of electrical power, which, in addition to any damage to pool superstructure, would cause a rise in fuel temperature due to loss of cooling. As discussed in Appendix F of this GEIS, if the spent fuel heats to a temperature on the order of $1,000^{\circ}\text{C}$ ($1,832^{\circ}\text{F}$), zirconium cladding on the spent fuel could ignite ("spent fuel pool zirconium fire"). Further, the spent fuel rod could burst due to high temperature, which could cause the collapse of the spent fuel itself.

Environmental Impacts of At-Reactoer Continued Storage of Spent Fuel

Radioactive aerosols and vapors released from the damaged spent fuel could be carried into the surrounding environment. Based on the discussion in Appendix F, the frequency of fuel being uncovered is very small and is between 5.8×10^{-7} and 2.4×10^{-6} /yr depending upon the seismic hazard assessment.

Climate Change

In NUREG–1738 (NRC 2001), the NRC determined that the overall frequency of catastrophic failure caused by a tornado is extremely low (i.e., the calculated frequency of such an event is less than 10^{-9} /yr). The GCRP (2014) determined that trends in the intensity and frequency of tornadoes and thunderstorm winds are uncertain and are being studied intensively. Although research suggests future increases in the frequency of environmental conditions favorable to severe thunderstorms, the scarcity of high-quality data, and the fact that these phenomena are too small to be directly represented in climate models, makes it difficult to project how the character of severe thunderstorms and tornadoes might change in the future (GCRP 2014). Therefore, the NRC assumes that the risk posed by tornadoes will be comparable to the risk determined in the 2001 study through the short-term storage timeframe.

In its 2001 study, the NRC determined that the frequency of significant damage to spent fuel pool support systems from straight-line winds, such as those from hurricanes, is very low. The NRC also estimated that the fuel uncover frequency for loss of offsite power caused by severe weather events was 1.1×10^{-7} /yr (NRC 2001). The Global Change Research Program determined that the United States and surrounding coastal waters may experience more intense hurricanes, but not necessarily an increase in the number of these storms that make landfall (GCRP 2014). An increase in the intensity of storms that make landfall as a result of climate change may increase the likelihood of both structural failures in buildings housing spent fuel pools and loss-of-offsite-power events. While the magnitude of the change in damage likelihood cannot be quantitatively predicted at this time, an increase in storm intensity is not expected to change the NRC's determination that the overall risk of external events on continued storage in spent fuel pools is small.

If climate change influences on sea-level rise create conditions adverse to safety, those changes would occur so slowly that the NRC has sufficient time to require licensees to implement corrective actions to identify and correct conditions adverse to safety. For example, the spent fuel could be transferred into dry casks and either relocated to higher elevation within the existing site or transported to a different site.

Summary

The NRC has examined the risk of severe accidents in spent fuel pools in several studies over the years. Based on these assessments, which include consideration of internal and external event initiators and climate change, the NRC concludes that the risk of severe accidents in spent fuel pools is small.

4.18.2.2 Severe Accidents in Dry Cask Storage Systems and DTSSs

Both the NRC and EPRI have completed probabilistic risk assessments that consider risks to the public of severe accidents involving dry cask storage system operations. Both studies were generic in nature and considered a range of events that could result in sufficient damage to dry casks to cause radiological releases. The EPRI probabilistic risk assessment examined PWR spent fuel in bolted casks (EPRI 2004). The NRC probabilistic risk assessment examined BWR spent fuel in a canister-based dry cask storage system (NRC 2007f). The results of both studies were evaluated by the NRC's Advisory Committee on Nuclear Waste during its 172nd meeting on July 20, 2006 (NRC 2006d).

In NUREG-1864, *A Pilot Probabilistic Risk Assessment of Dry Cask Storage System at the Nuclear Power Plant*, the NRC analyzed various phases of the dry cask storage process from loading fuel from the spent fuel pool, preparing the cask for storage and transferring it outside the reactor building, moving the cask from the reactor building to the storage pad, and storing the cask for 20 years on the storage pad (NUREG 2007f). The study assessed a comprehensive list of initiating events, including dropping the cask during handling and external events during onsite storage (such as earthquakes, floods, high winds, lightning strikes, accidental aircraft crashes, and pipeline explosions). The study also modeled potential cask failures from mechanical and thermal loads. As shown in Table 18 of NUREG-1864, the largest conditional consequences to an individual person of postulated accidents are expected to range from 2.8 mSv (280 mrem), at a distance of less than 1.6 km (1 mi), up to 1.85 Sv (185 rem) at the same distance. For example, a postulated 5.8-m (19-ft) drop of a multipurpose canister while being lowered from the transfer cask to the storage cask would result in larger consequences. This drop can happen due to a design basis earthquake during canister handling operation and has the most severe consequence of potential drops. However, the probability of a release causing this dose consequence, which includes consideration of the initiating event frequency and conditional probability of release, given the event occurs, is about $3 \times 10^{-5}/\text{yr}$.

EPRI's 2004 study covered various phases of the dry cask storage process. Like the NRC study, the EPRI study considered a comprehensive list of initiating events, including dropping the cask during handling and events caused by severe natural phenomena. For average meteorological conditions, EPRI's estimates of the conditional downwind consequences from accidents to an individual person range from 0.00018 mSv (0.018 mrem) at a distance of 0.5 km

Environmental Impacts of At-Reactor Continued Storage of Spent Fuel

(0.3 mi) up to 0.194 Sv (19.4 rem) at a distance of 0.4 km (0.25 mi). The lowest consequences for events in which there could be any radiological release are associated with dropping a cask. The highest consequences are associated with an impact to the cask followed by a fire, such as could occur after an impact of an aircraft. The probability of each type of event considered by EPRI is less than $5.3 \times 10^{-6}/\text{yr}$.

Therefore, although the consequences would exceed NRC public dose standards contained in 10 CFR Part 20 (e.g., 100-mrem/yr dose limits for members of the public), the likelihood of the event is very low. Therefore, the environmental risk of an accident is SMALL.

The use of a DTS for the purposes of this continued storage environmental analysis represents a reasonable assumption for how future licensees are likely to repackage spent fuel, should repackaging activities become necessary during continued storage. However, the NRC has not received an application to construct and operate a DTS and, therefore, has not analyzed the environmental impacts of severe accidents at a DTS. As described in Section 2.1.4, the DOE prepared, and NRC reviewed, a topical safety analysis report for a conceptual design of a DTS. DOE's topical safety analysis report includes some of the types of information and analyses required to license a DTS, some of which is provided in this GEIS to describe the environmental impacts of constructing, operating, and replacing a DTS. DOE's analysis in the topical safety analysis report did not include consideration of severe accidents. However, the NRC's overall requirements for licensing spent fuel storage facilities under 10 CFR Part 72 ensure that the risk of severe accidents at a DTS would be small. Although the NRC has not analyzed the environmental impacts of severe accidents at a DTS, given that the amount of spent fuel being handled in a DTS is limited to the contents of a single dry cask, the consequences described above for cask drops provide some insight into the consequences of severe accidents at a DTS. Because compliance with NRC regulations for spent fuel handling and storage would likely make the risk of severe accidents at a DTS small, and the consequences of any severe accident at a DTS would likely be comparable to or less than that for the cask drop accident described above, the NRC concludes the likely impacts from activities at a DTS would be small.

Climate Change

In the probabilistic risk assessments described above, both EPRI and the NRC evaluated high winds and floods as initiating events for accidents. The dry cask storage system that was evaluated by the NRC was the Holtec HI-STORM 100 system. This vertical cask system is in common use (see Appendix G) at nuclear power plants. As discussed in more detail below, the NRC believes that NUREG-1864 provides a useful analysis of the types of high winds and floods that could be expected to occur as a result of climate change. Therefore, the results of the NRC's 2007 study (NUREG-1864, NRC 2007f) illustrate the effects of climate change for the purposes of this GEIS.

Environmental Impacts of At-Reactor Continued Storage of Spent Fuel

NUREG–1864 concluded that winds in excess of 644 km/hr (400 mph) would be required to cause storage cask tip-over, and winds in excess of 1,448 km/hr (900 mph) would be required to propel a heavy object into a storage cask with enough force to cause significant damage. There is no recorded evidence of tornado wind speeds in excess of 480 km/hr (300 mph) (NRC 2007f). Very few hurricanes have achieved wind speeds of 310 km/hr (190 mph) (Bender et al. 2010). Further, although climate models project future increases in the frequency of environmental conditions favorable to severe thunderstorms, the scarcity of high-quality data associated with the intensity and frequency of tornadoes and thunderstorm winds, combined with the fact that these phenomena are too small to be directly represented in climate models, makes it difficult to project how the character of severe thunderstorms might change in the future (GCRP 2014). Therefore, the NRC assumes that the risk posed by high winds remains very low.

Floods were also considered in NUREG–1864, but deemed not able to affect the plant that was the subject of the study. In general, the effects of floods on dry cask storage systems can include cask sliding, tip-over, and blockage of ventilation ports by water and silting of air passages. Other effects include water scouring below ISFSI foundations, burial under debris, and severe temperature gradients resulting from rapid cooling from immersion in water (NRC 2007f). However, based on the relatively slow rate of change in flood risk over time, the NRC is confident that any regulatory action that may be necessary will be taken in a timely manner to ensure the safety of dry cask storage systems.

If climate change influences on sea-level rise create conditions adverse to safety, the NRC has sufficient time to require licensees to implement corrective actions to identify and correct conditions adverse to safety. Some of the specific corrective actions that could be taken include elevating the existing ISFSI, relocating dry casks to higher ground onsite, or transporting the spent fuel to a different site.

Summary

The NRC has examined the risk of severe accidents in dry cask storage systems. Based on this assessment, which includes consideration of internal and external event initiators and climate change, the NRC concludes that the risk of severe accidents in dry cask storage systems is small.

4.18.2.3 Conclusion

The NRC has examined the risk of severe accidents in spent fuel pools and dry cask storage systems in several studies over the years. Based on these assessments, the NRC concludes that the risk of severe accidents in spent fuel pools and dry cask storage systems is SMALL.

4.19 Potential Acts of Sabotage or Terrorism

This section describes the environmental impacts of potential acts of sabotage or terrorism involving the continued storage of spent fuel. The NRC regulates the security of radioactive material as part of its domestic safeguards program.⁵ This program provides for regulatory requirements; licensing and NRC oversight of facility access control; fitness for duty; material control and accounting; and physical protection of spent fuel storage in onsite spent fuel pools, at-reactor and away-from-reactor ISFSIs, and monitored retrievable storage installations.

This GEIS considers the potential risks of accidents and acts of sabotage or terrorism at spent fuel storage facilities. In 1984 and 1990, the NRC provided some discussion of the reasons why it believed that the possibility of a major accident or sabotage with offsite radiological impacts at a spent fuel storage facility is extremely remote. In the 2010 update to the Waste Confidence Decision, the Commission gave considerable attention to the issue of terrorism and spent fuel management (75 FR 81037). The Commission concluded that

[t]oday spent fuel is better protected than ever. The results of security assessments, existing security regulations, and the additional protective and mitigative measures imposed since September 11, 2001, provide high assurance that the spent fuel in both spent fuel pools and in dry storage casks will be adequately protected (75 FR 81037).

There is dispute among the United States Courts of Appeals as to whether NEPA analyses require consideration of terrorist attacks. In *San Luis Obispo Mothers for Peace v. NRC*, the Court of Appeals for the Ninth Circuit held that the NRC needed to consider the environmental impacts of terrorism in its NEPA reviews. In contrast, in 2009, the Court of Appeals for the Third Circuit upheld the NRC's position that terrorist attacks are too far removed from the natural or expected consequences of agency action to require environmental analysis. Nonetheless, because some continuing storage will occur within the Ninth Circuit, this GEIS discusses the environmental impacts of a successful terrorist attack to comply with *San Luis Obispo Mothers for Peace v. NRC*. The Ninth Circuit left to agency discretion the precise manner in which the NRC undertakes a NEPA-terrorism review (NRC 2008c).

The environmental impacts of a successful terrorist attack, if one occurs, could be significant and destabilizing. The impact determinations for these attacks, however, are made with consideration of the low probability of successful attack. The environmental impact determination with respect to successful terrorist attacks, therefore, is based on risk, which the NRC defines as the product of the probability, even if only a qualitative assessment of

⁵ The regulations in 10 CFR that are most applicable to the domestic safeguards program for spent nuclear fuel storage beyond the licensed life for operation are contained in Parts 11, 25, 26, 70, 72, 73, and 74.

Environmental Impacts of At-Reactor Continued Storage of Spent Fuel

probability is available, and the consequences of a successful attack. This means that a high-consequence, low-probability event could result in a small impact determination if the risk is sufficiently low.

Impacts from terrorist acts for spent fuel pool storage might occur only during the short-term timeframe, and the impacts for dry cask storage are substantially the same across the three timeframes. Therefore, this section of the GEIS follows a different format from other sections by presenting the various accident types only once. The three storage timeframes (short-term, long-term, and indefinite, as described in Chapter 1) apply as follows:

- During short-term storage, the probability and consequences of attacks on both the onsite spent fuel pool and at-reactor ISFSI are considered.
- Beyond short-term storage, spent fuel is assumed to have been moved from the spent fuel pool to an at-reactor ISFSI. Therefore, during long-term and indefinite storage timeframes, only the probability and consequences of attacks on the at-reactor ISFSI are applicable.

4.19.1 Attacks on Spent Fuel Pools

The NRC has determined that the probability of a successful terrorist attack on a spent fuel pool, although numerically indeterminable, is very low (73 FR 46204). To support this conclusion, the NRC reviewed the characteristics of spent fuel pools discussed in Chapter 2 and assessed how those features would deter terrorist attacks. Spent fuel pool structural features, complemented by the deployment of effective and visible physical security protection measures, described further below, are deterrents to terrorist attack. In addition, the emergency procedures developed for reactor accidents provide a means for mitigating the potential consequences of terrorist attacks (73 FR 46204).

Further, after the terrorist attacks of September 11, 2001, the NRC issued a series of Security Orders to require licensees to implement additional interim security measures. Through these Orders, the NRC supplemented the Design Basis Threat rule for radiological sabotage⁶ and mandated specific licensee enhancement of security force training, access authorization, and defensive strategies, plus additional mitigative measures. In addition, through generic communications, the NRC specified expectations for enhanced notifications to the NRC for certain security events or suspicious activities.

In response to the Security Orders, facility licensees revised their physical security plans, access authorization programs, training and qualification plans, and safeguards contingency

⁶ The definition for design basis threat for radiological sabotage is contained in 10 CFR 73.1(a)(1), which describes a determined violent external assault, attack by stealth, or deceptive actions, including diversionary actions, by an adversary force capable of operating in each of several modes and with attributes, assistance, and equipment as defined in the regulation. Under NRC's Design Basis Threat rule, licensees must be able to defend against these threats with high assurance.

Environmental Impacts of At-Reactoer Continued Storage of Spent Fuel

plans. These revisions enhanced physical security with increased patrols, augmented security forces and capabilities, added additional security posts, added additional physical barriers, and required vehicle checks at greater standoff distances. Procedural enhancements resulted in greater coordination with law enforcement authorities, augmented security and emergency response training, equipment, and communication, and more restrictive site access controls for personnel, including expanded, expedited, and more thorough employee background investigations (NRC 2008c).

In 2007, the NRC amended its regulations in 10 CFR Part 73 governing licensee capability to defend against design basis threats of radiological sabotage to capture experience and insights gained by the NRC in implementing those requirements and to redefine the level of security requirements necessary to ensure adequate protection of the public health and safety and common defense and security (72 FR 12705). In 2009, the NRC amended its regulations in 10 CFR Parts 50, 52, 72, and 73 to codify the appropriate requirements from the Security Orders and update those requirements with new insights gained from implementation of the Security Orders, review of site security plans, implementation of the enhanced baseline inspection program, and NRC evaluation of force-on-force exercises. This rulemaking, which includes cybersecurity requirements, also updated the NRC's security regulatory framework for the licensing of new nuclear power plants (74 FR 13926). The cybersecurity requirements, which are codified as 10 CFR 73.54, require licensees to provide high assurance that digital computer and communication systems and networks are adequately protected against cyber-attacks, up to and including design basis threats as described in 10 CFR 73.1, "Purpose and Scope." To ensure that design basis threats described in 10 CFR 73.1 remain a valid basis for the design of physical protection systems, the NRC staff performs extensive analysis of intelligence information gathered from classified and open sources and provides the results of this analysis, including recommendations for increasing or decreasing the design basis threat for NRC-licensed facilities, in an annual written report to the Commission.

As discussed in more detail in the NRC's response to a draft U.S. Government Accountability Office report on material control and accounting of spent fuel, with regard to theft and diversion of spent fuel, the NRC believes that the likelihood that an adversary could steal spent fuel from a spent fuel pool is extremely low, given the security and radiation protection measures in place, the ease of detectability, and the physically disabling radiation from the spent fuel. Further, the NRC also does not consider the threat of a knowledgeable, active insider stealing a spent fuel rod, or portion thereof, to be credible (NRC 2005d).

The NRC has determined that these measures and national anti-terrorist measures to prevent, for example, aircraft hijackings, coupled with the robust nature of spent fuel pools, make the probability of a successful terrorist attack, although numerically indeterminable, very low (73 FR 46204).

Environmental Impacts of At-Reactor Continued Storage of Spent Fuel

Although a successful act of sabotage or terrorism by an armed attack is low in probability, the consequences of such an act could be severe. A discussion of a postulated spent fuel pool fire resulting from loss of pool water, which could result from a successful attack, is provided in Appendix F. The conditional consequences described in Appendix F include downwind collective radiation doses above one million person-rem, up to 191 early fatalities, and economic damages exceeding \$50 billion. However, given the very low probability of a successful attack with these consequences, the NRC determined that the risk of successful attack is small.

4.19.2 Attacks on ISFSIs and DTS

Before September 11, 2001, the NRC's regulations that apply to future DTS⁷ licensees and current and future ISFSI licensees required licensees to comply with the security requirements specified in 10 CFR Part 72, "Licensing Requirements for the Independent Storage of Spent Nuclear Fuel, High-Level Radioactive Waste, and Reactor-Related Greater than Class C Waste," and 10 CFR Part 73, "Physical Protection of Plants and Materials." After the attacks of September 11, 2001, the NRC enhanced security for all facilities licensed to store spent fuel through a combination of the existing security regulations and the issuance of Security Orders to individual ISFSI licensees. These orders ensured that a consistent, comprehensive protective strategy was in place for all ISFSIs.

As discussed in Chapter 2, two types of ISFSI licenses (general and specific) are available for the storage of spent fuel; a future DTS would be licensed under the specific license provisions of 10 CFR Part 72. Physical security requirements for these licensees appear in various sections of 10 CFR Part 73, depending on the type of licensee. The regulations in 10 CFR 72.212(b)(9), "Conditions of General License Issued under §72.210," require general ISFSI licensees to establish a physical protection program that protects the spent fuel against the design basis threat for radiological sabotage in accordance with applicable security requirements imposed on nuclear power reactor licensees under 10 CFR 73.55, "Requirements for Physical Protection of Licensed Activities in Nuclear Power Reactors Against Radiological Sabotage." For general-license ISFSIs, neither 10 CFR 72.212(b)(9) nor 10 CFR 73.55 imposes a dose limit for security events (i.e., acts of radiological sabotage). For specifically licensed ISFSIs and DTSs, NRC regulations at 10 CFR 73.51, "Requirements for the Physical Protection of Stored Spent Nuclear Fuel and High-Level Radioactive Waste," require licensees to establish and maintain a physical protection system that provides high assurance that licensed activities do not constitute an unreasonable risk to public health and safety. The physical protection system must protect against the loss of control of the ISFSI or DTS that could be sufficient to cause a radiation exposure exceeding the dose limitation in 10 CFR 72.106 (NRC 2007g).

⁷ As described in Section 2.1.4 of this GEIS, there are currently no DTS licensees, but these requirements would apply to persons that seek to build and operate a DTS.

Environmental Impacts of At-Reactor Continued Storage of Spent Fuel

In general, the potential for theft or diversion of light water reactor spent fuel from the ISFSI with the intent of using the contained special nuclear material for nuclear explosives is not considered credible because of (1) the inherent protection afforded by the massive reinforced-concrete storage module and the steel storage canister; (2) the unattractive form of the contained special nuclear material, which is not readily separable from the radioactive fission products; and (3) the immediate hazard posed by the high radiation levels of the spent fuel to persons not provided radiation protection (NRC 1991c, 1992).

The immediate hazard posed by the high radiation levels of the spent fuel will, however, diminish over time, depending on burnup and the level of radiation deemed to provide adequate self-protection. Self-protection refers to the incapacitation inflicted upon a recipient from inherent radiation emissions in a timeframe that prevents the recipient from completing an intended task (Coates et al. 2005). This means that spent fuel could become more susceptible to possible theft or diversion over long periods of time. This susceptibility depends on the burnup; higher burnup spent fuel provides adequate self-protection for longer time periods. The Blue Ribbon Commission on America's Nuclear Future: Report to the Secretary of Energy (BRC 2012) concluded:

As the duration of storage is extended, the amount of penetrating radiation emitted by spent fuel will diminish. In the process, the fuel loses a degree of "self-protection" against theft or diversion: in other words, unshielded exposure to the fuel becomes less immediately debilitating and hence creates less of a deterrent to handling by unauthorized persons. This means that over long time periods (perhaps a century or more, depending on burnup and the level of radiation that is deemed to provide adequate self-protection), the fuel could become more susceptible to possible theft or diversion (although other safeguards would remain in place). This in turn could change the security requirements for older spent fuel. Extending storage to timeframes of more than a century could thus require increasingly demanding and expensive security protections at storage sites.

Further, for non-light water reactor spent fuel, the period of self-protection may be lower than that of light water reactor spent fuel, depending on the burnup of the spent fuel and the isotopic composition of the special nuclear material (i.e., the attractiveness of the material for diversion).

Thus, additional security requirements may be necessary in the future if spent fuel remains in storage for a substantial period of time. Under those circumstances, it is reasonable to assume that, if necessary, the NRC will issue orders or enhance its regulatory requirements for ISFSI and DTS security, as appropriate, to ensure adequate protection of public health and safety and the common defense and security.

The NRC has determined that the measures described above, coupled with the robust nature of dry cask storage systems, make the probability of a successful terrorist attack, although

Environmental Impacts of At-Reactor Continued Storage of Spent Fuel

numerically indeterminable, very low. Furthermore, the probability of successfully detonating an improvised nuclear device (IND) is even more remote because there are significant steps required to manufacture an IND from spent fuel, including theft of the spent fuel, removal of the spent fuel from the site, and significant chemical and metallurgical processing steps to manufacture an IND.

The conditional consequence of a successful theft and diversion attack that ultimately results in detonation of an IND would be catastrophic. The National Academies and U.S. Department of Homeland Security have estimated environmental effects caused by detonation of an IND. For a 10-kiloton device, the shockwave could kill exposed persons within 0.6 km (0.4 mi); the heat effects could kill persons within 1.8 km (1.1 mi); and initial radiation doses would exceed 4 Gy (400 rad) up to 1.3 km (0.8 mi) away. Radioactive fallout could result in doses above 4 Gy (400 rad) out to 9.7 km (6 mi). Long-term environmental effects would include contaminated property and food supplies, death and illness, loss of jobs, and costs to local, State, and Federal governments to restore property and goods (National Academies 2005).

With respect to the potential for radiological sabotage, after the NRC issued the license for the Diablo Canyon ISFSI in March 2004, the Ninth Circuit reviewed the licensing action and, as discussed, required the NRC to consider terrorist acts in its environmental review associated with this licensing action. In response to the Ninth Circuit decision, the NRC supplemented its EA and finding of no significant impact for the Diablo Canyon ISFSI to address the likelihood and the potential consequences of a terrorist attack directed at the ISFSI (NRC 2007g):

The NRC staff reviewed the analyses performed for generic ISFSI security assessments, and compared their assumptions to the relevant features of the Diablo Canyon ISFSI. Based on this comparison, the staff determined that the assumptions used in these generic security assessments regarding storage cask design, source term (amount of radioactive material released), and atmospheric dispersion, were representative, and in some cases, conservative, relative to the actual conditions at the Diablo Canyon ISFSI. In fact, because of the specific characteristics of the spent fuel authorized for storage at the Diablo Canyon ISFSI (lower burnup fuel), and the greater degree of dispersion of airborne radioactive material likely to occur at the site, any dose to affected residents nearest to the Diablo Canyon site will tend to be much lower than the doses calculated for the generic assessments. Based on these considerations, the dose to the nearest affected resident, from even the most severe plausible threat scenarios – the ground assault and aircraft impact scenarios – would likely be below 5 rem. In many scenarios, the hypothetical dose to an individual in the affected population could be substantially less than 5 rem, or none at all. In some situations, emergency planning actions could provide an additional measure of protection to mitigate the consequences, in the unlikely event that a successful attack were carried out at the Diablo Canyon ISFSI.

The specific dose results from the 2007 Diablo Canyon ISFSI EA Supplement were derived from the generic analysis performed as part of ISFSI security assessments (NRC 2003). The site-specific assumption in the EA Supplement was the distance to the nearest resident from the Diablo Canyon ISFSI, which is about 2.4 km (1.5 mi). By comparison, this is more than the average distance to nearby residences for other specifically licensed ISFSIs, which is about 1.6 km (1 mi). Doses at closer residences could be larger, but are likely to remain well below levels that could cause immediate health effects. The NRC took both the estimated dose and the likelihood into consideration in making a finding of no significant impact. Thus, the NRC determines that the environmental risk is SMALL. In addition, the environmental risk of impacts on property and land resulting from downwind settling of airborne radioactive material would be SMALL.

In February 2011, after a challenge to the Supplemental Environmental Assessment, the Ninth Circuit issued a decision affirming its sufficiency (*San Luis Obispo Mothers for Peace v. NRC*).

The consequences of successful radiological sabotage at a DTS would be similar to the consequences of postulated accidents at a DTS. For example, Section 4.18.1.2 of this GEIS describes a design basis event at a DTS involving 21 damaged spent fuel assemblies in an open cask that results in a release of radioactive material through an inoperable ventilation system. The total dose to a person standing 100 m (330 ft) away is estimated to be 7.21 mSv (721 mrem).

4.19.3 Conclusion

The NRC finds that even though the environmental consequences of a successful attack on a spent fuel pool during continued storage would be large, the very low probability of a successful attack ensures that the environmental risk is SMALL. Similarly, for operational ISFSIs and DTSs during continued storage, the NRC finds that the environmental risk is SMALL.

4.20 Summary

The impact determinations for at-reactor storage for each resource area for each timeframe are summarized in Table 4-2. For most of the resource areas, the impact determinations for all three timeframes are SMALL. Continued storage is not expected to adversely affect special species and habitats. For accidents (design basis and severe) and terrorism considerations, the environmental risks of continued storage are SMALL.

However, for a few resource areas, impact determinations are greater than SMALL and varied for the three timeframes. For the long-term storage and indefinite storage timeframes, during which ground-disturbing activities may occur, impacts on historic and cultural resources range from SMALL to LARGE. The impacts from management and disposal of nonradioactive waste would be SMALL for both the short-term and long-term timeframes but SMALL to MODERATE for indefinite storage.

Environmental Impacts of At-Reactor Continued Storage of Spent Fuel

Table 4-2. Summary of Environmental Impacts of Continued At-Reactor Storage

Resource Area	Short-Term Storage	Long-Term Storage	Indefinite Storage
Land Use	SMALL	SMALL	SMALL
Socioeconomics	SMALL	SMALL	SMALL
Environmental Justice	Disproportionately high and adverse impacts are not expected		
Air Quality	SMALL	SMALL	SMALL
Air Emissions	SMALL	SMALL	SMALL
Thermal Releases	SMALL	SMALL	SMALL
Climate Change	SMALL	SMALL	SMALL
Geology and Soils	SMALL	SMALL	SMALL
Surface Water			
Quality	SMALL	SMALL	SMALL
Consumptive Use	SMALL	SMALL	SMALL
Groundwater			
Quality	SMALL	SMALL	SMALL
Consumptive Use	SMALL	SMALL	SMALL
Terrestrial Resources	SMALL	SMALL	SMALL
Aquatic Ecology	SMALL	SMALL	SMALL
Special Status Species and Habitats	Impacts on Federally listed threatened and endangered species and Essential Fish Habitat would be determined as part of the consultations for the ESA and Magnuson-Stevens Fishery Conservation and Management Act		
Historic and Cultural Resources	SMALL	SMALL to LARGE	SMALL to LARGE
Noise	SMALL	SMALL	SMALL
Aesthetics	SMALL	SMALL	SMALL
Waste Management			
LLW	SMALL	SMALL	SMALL
Mixed Waste	SMALL	SMALL	SMALL
Nonradioactive Waste	SMALL	SMALL	SMALL to MODERATE
Transportation	SMALL	SMALL	SMALL
Traffic	SMALL	SMALL	SMALL
Health Impacts	SMALL	SMALL	SMALL
Public and Occupational Health	SMALL	SMALL	SMALL
Accidents	SMALL	SMALL	SMALL
Sabotage or Terrorism	SMALL	SMALL	SMALL

4.21 References

10 CFR Part 11. *Code of Federal Regulations*, Title 10, *Energy*, Part 11, “Criteria and Procedures for Determining Eligibility for Access to or Control Over Special Nuclear Material.” Washington, D.C.

10 CFR Part 20. *Code of Federal Regulations*, Title 10, *Energy*, Part 20, “Standards for Protection Against Radiation.” Washington, D.C.

10 CFR Part 25. *Code of Federal Regulations*, Title 10, *Energy*, Part 25, “Access Authorization.” Washington, D.C.

10 CFR Part 26. *Code of Federal Regulations*, Title 10, *Energy*, Part 26, “Fitness for Duty Programs.” Washington, D.C.

10 CFR Part 50. *Code of Federal Regulations*, Title 10, *Energy*, Part 50, “Domestic Licensing of Production and Utilization Facilities.” Washington, D.C.

10 CFR Part 51. *Code of Federal Regulations*, Title 10, *Energy*, Part 51, “Environmental Protection Regulations for Domestic Licensing and Related Regulatory Functions.” Washington, D.C.

10 CFR Part 52. *Code of Federal Regulations*, Title 10, *Energy*, Part 52, “Licenses, Certifications, and Approvals for Nuclear Power Plants.” Washington, D.C.

10 CFR Part 70. *Code of Federal Regulations*, Title 10, *Energy*, Part 70, “Domestic Licensing of Special Nuclear Material.” Washington, D.C.

10 CFR Part 72. *Code of Federal Regulations*, Title 10, *Energy*, “Licensing Requirements for the Independent Storage of Spent Nuclear Fuel, High-Level Radioactive Waste, and Reactor-Related Greater Than Class C Waste.” Washington, D.C.

10 CFR Part 73. *Code of Federal Regulations*, Title 10, *Energy*, Part 73, “Physical Protection of Plants and Materials.” Washington, D.C.

10 CFR Part 74. *Code of Federal Regulations*, Title 10, *Energy*, Part 74, “Material Control and Accounting of Special Nuclear Material.” Washington, D.C.

10 CFR Part 100. *Code of Federal Regulations*, Title 10, *Energy*, Part 100, “Reactor Site Criteria.” Washington, D.C.

Environmental Impacts of At-Reactor Continued Storage of Spent Fuel

36 CFR Part 60. *Code of Federal Regulations*, Title 36, *Parks, Forests, and Public Property*, Part 60, “National Registry of Historic Places.” Washington, D.C.

36 CFR Part 800. *Code of Federal Regulations*, Title 36, *Parks, Forests, and Public Property*, Part 800, “Protection of Historic Properties.” Washington, D.C.

40 CFR Part 93. *Code of Federal Regulations*, Title 40, *Protection of the Environment*, Part 93, “Determining Conformity of Federal Actions to State or Federal Implementations Plans.” Washington, D.C.

40 CFR Part 125. *Code of Federal Regulations*, Title 40, *Protection of the Environment*, Part 125, “Criteria and Standards for the National Pollutant Discharge Elimination System.” Washington, D.C.

50 CFR Part 402. *Code of Federal Regulations*, Title 50, *Wildlife and Fisheries*, Part 402, “Interagency Cooperation—Endangered Species Act of 1973, as Amended.” Washington, D.C.

50 CFR Part 600. *Code of Federal Regulations*, Title 50, *Wildlife and Fisheries*, Part 600, “Magnuson–Stevens Act Provisions.” Washington, D.C.

59 FR 7629. February 16, 1994. “Executive Order 12898: Federal Actions to Address Environmental Justice in Minority Populations and Low-Income Populations.” *Federal Register*, Executive Office of the President, Washington, D.C.

69 FR 52040. August 24, 2004. “Policy Statement on the Treatment of Environmental Justice Matters in NRC Regulatory and Licensing Actions.” *Federal Register*, U.S. Nuclear Regulatory Commission, Washington, D.C.

72 FR 12705. March 19, 2007. “Design Basis Threat.” *Federal Register*, U.S. Nuclear Regulatory Commission, Washington, D.C.

73 FR 46204. August 8, 2008. “The Attorney General of Commonwealth of Massachusetts, the Attorney General of California; Denial of Petitions for Rulemaking.” *Federal Register*, U.S. Nuclear Regulatory Commission, Washington, D.C.

74 FR 13926. March 27, 2009. “Power Reactor Security Requirements, Final Rule.” *Federal Register*, U.S. Nuclear Regulatory Commission, Washington, D.C. Accession No. ML080570264.

75 FR 81037. December 23, 2010. “Waste Confidence Decision Update.” *Federal Register*, U.S. Nuclear Regulatory Commission, Washington, D.C.

Environmental Impacts of At-Reactors Continued Storage of Spent Fuel

AEC (U.S. Atomic Energy Commission). 1972. *Environmental Survey of Transportation of Radioactive Materials to and From Nuclear Power Plants*. WASH-1238, Washington, D.C. Available at http://www.osti.gov/energycitations/product.biblio.jsp?osti_id=4569134.

ANSI/ANS (American National Standards Institute/American Nuclear Society). 1992. *Design Criteria for an Independent Spent Fuel Storage Installation (Dry Storage Type)*. ANSI/ANS 57.9-1992, La Grange Park, Illinois. Accession No. ML030560583.

ASME International. 2010. *Rules for Construction of Overhead and Gantry Cranes (Top Running Bridge, Multiple Girder)*. ASME NOG-1, New York, New York.

Bald and Golden Eagle Protection Act of 1940, as amended. 16 USC 668-668d *et seq.*

Beitinger, T.L., W.A. Bennett, and R.W. McCauley. 2000. "Temperature Tolerances of North American Freshwater Fishes Exposed to Dynamic Changes in Temperature." *Environmental Biology of Fishes* 58:237-275, New York, New York.

Bender, M.A., T.R. Knutson, R.E. Tuleya, J.J. Sirutis, G.A. Vecchi, S.T. Garner, and I.M. Held. 2010. "Modeled Impact of Anthropogenic Warming on the Frequency of Intense Atlantic Hurricanes." *Science* 327(5964):454-458, Washington, D.C.

BRC (Blue Ribbon Commission). 2012. *Transportation and Storage Subcommittee Report to the Full Commission: Updated Report*. Washington, D.C. Available at http://cybercemetery.unt.edu/archive/brc/20120620215746/http://brc.gov/sites/default/files/documents/final_updated_ts_report_012612.pdf.

Clean Water Act (see Federal Water Pollution Control Act of 1972).

Coastal Zone Management Act of 1972, as amended. 16 USC 1451 *et seq.*

Christensen, M.R., D.C. Koelsch, L. Stewart, and M.A. McKinnon. 2000. *Spent Nuclear Fuel Dry Transfer System Cold Demonstration Project*. INEEL/EXT-99-01335, Idaho National Engineering and Environmental Laboratory, Idaho Falls, Idaho. Available at <http://www.inl.gov/technicalpublications/Documents/3318121.pdf>.

Coates, C.W., B.L. Broadhead, A.M. Krichinsky, R.W. Leggett, M.B. Emmett, and J.B. Hines. 2005. *Radiation Effects on Personnel Performance Capability and a Summary of Dose Levels for Spent Research Reactor Fuels*. ORNL/TM-2005/261, Oak Ridge, Tennessee. Available at http://web.ornl.gov/~webworks/cppr/y2007/rpt/124368.pdf?origin=publication_detail.

Consumers Energy Company and Nuclear Management Company, LLC. 2001. *Palisades Nuclear Plant Biological Assessment of the 1999 Cooling Water Flow Increase at the Palisades*

Environmental Impacts of At-Reactor Continued Storage of Spent Fuel

Plant, near South Haven, Michigan. Consumers Energy Company, Jackson, Michigan, and Nuclear Management Company, LLC, Covert, Michigan.

DOE (U.S. Department of Energy). 1996. *Dry Transfer System Topical Safety Analysis Report.* Volumes 2 and 3, Washington D.C. Accession Nos. ML060730037, ML060730040.

DOE (U.S. Department of Energy). 2002. *Final Environmental Impact Statement for a Geologic Repository for the Disposal of Spent Nuclear Fuel and High-Level Radioactive Waste at Yucca Mountain, Nye County, Nevada.* DOE/EIS-0250, Office of Civilian Radioactive Waste Management, North Las Vegas, Nevada. Accession No. ML14024A327.

DOE (U.S. Department of Energy). 2012. *Managing Aging Effects on Dry Cask Storage Systems for Extended Long-Term Storage and Transportation of Used Fuel.*

FCD-USED-2012-000119, Washington, D.C. Available at

<http://www.ipd.anl.gov/anlpubs/2012/07/73873.pdf>.

Duke Energy. 2013. Letter from Duke Energy to NRC, dated September 30, 2013, regarding “Response to NRC Request for Additional Information Dated August 1, 2013 Regarding the Decommissioning Funding Status Report for the Independent Spent Fuel Storage Installations.” Charlotte, North Carolina. Accession No. ML13275A203.

Endangered Species Act of 1973 (ESA), as amended. 16 USC 1531 *et seq.*

EPA (U.S. Environmental Protection Agency). 1974. *Information on Levels of Environmental Noise Requisite to Protect Public Health and Welfare with an Adequate Margin of Safety.* 550/9-74-004, Washington, D.C. Accession No. ML12241A393.

EPA (U.S. Environmental Protection Agency). 2002. *Case Study Analysis for the Proposed Section 316(b) Phase II Existing Facilities Rule.* EPA-821-R-02-002, Office of Science and Technology, Washington, D.C. Available at

http://water.epa.gov/lawsregs/lawsguidance/cwa/316b/phase2/casestudy_index.cfm.

EPA (U.S. Environmental Protection Agency). 2013. *Inventory of U.S. Greenhouse Gas Emissions and Sinks: 1990-2011.* EPA 430-R-13-001, Washington, D.C. Accession No. ML13331A473.

EPRI (Electric Power Research Institute). 2002. “Water and Sustainability.” Volume 3 of *U.S. Water Consumption for Power Production—The Next Half Century.* Palo Alto, California. Available at <http://www.circleofblue.org/waternews/wp-content/uploads/2010/08/EPRI-Volume-3.pdf>.

Environmental Impacts of At-Reactor Continued Storage of Spent Fuel

EPRI (Electric Power Research Institute). 2004b. *Probability Risk Assessment (PRA) of Bolted Storage Casks: Updated Quantification and Analysis Report*. Report 1009691, Palo Alto, California. Available at <http://www.epri.com/abstracts/Pages/ProductAbstract.aspx?ProductId=000000000001009691>.

EPRI (Electric Power Research Institute). 2010. *Industry Spent Fuel Storage Handbook*. Palo Alto, California. Available at <http://www.epri.com/abstracts/Pages/ProductAbstract.aspx?ProductId=000000000001021048>.

Exelon (Exelon Generation Company, LLC, LaSalle County Station). 2001. Letter from Exelon to NRC, dated August 17, 2001, regarding "Environmental Non-Routine Event Report for Exelon Generation Company, LLC, LaSalle County Station." Marseilles, Illinois. Accession No. ML012330070.

Exelon (Exelon Generation Company, LLC, LaSalle County Station). 2005. Letter from Exelon to NRC, dated July 28, 2005, regarding "Environmental Non-Routine Event Report for Exelon Generating Company, LLC—Braidwood Station." Marseilles, Illinois. Accession No. ML052160140.

Federal Water Pollution Control Act of 1972, as amended (also referred to as the Clean Water Act). 33 USC 1251 *et seq.*

Fish and Wildlife Coordination Act of 1934, as amended. 16 USC 661-667e *et seq.*

FWS/NMFS (U.S. Fish and Wildlife Service/National Marine Fisheries Service). 1998. *Endangered Species Consultation Handbook, Procedures for Conducting Consultation and Conference Activities Under Section 7 of the Endangered Species Act*. Washington, D.C. Accession No. ML12325A215.

Foster Wheeler (Foster Wheeler Environmental Corporation). 2003. Letter from D.I. Rogers, Jr. to NRC, dated November 14, 2003, regarding "Idaho Spent Fuel (ISF) Facility Submittal of Amendment 3 to License Application, Docket No. 72.25, TAC No. L23389." Morris Plains, New Jersey. Accession No. ML033240044.

GCRP (U.S. Global Change Research Program). 2014. *Climate Change Impacts in the United States: The Third National Climate Assessment*. J.M. Melillo, T.C. Richmond, and G.W. Yohe, eds. U.S., Government Printing Office, Washington, D.C. Accession No. ML14129A233.

Hall, C.A.S., R. Howarth, B. Moore, III, and C.J. Vorosmarty. 1978. "Environmental Impacts of Industrial Energy Systems in the Coastal Zone." *Annual Review of Energy* 3:395–475, Palo Alto, California.

Environmental Impacts of At-Reactor Continued Storage of Spent Fuel

Magnuson–Stevens Fishery Conservation and Management Act of 1976, as amended. 16 USC 1801 *et seq.*

Marine Mammal Protection Act of 1972, as amended. 16 USC 1361-1421h *et seq.*

Migratory Bird Treaty Act of 1918, as amended. 16 USC 703–712 *et seq.*

National Academies. 2005. “News and Terrorism—Communicating in a Crisis: Nuclear Attack.” National Academies and the U.S. Department of Homeland Security, Washington, D.C. Available at: http://www.dhs.gov/xlibrary/assets/prep_nuclear_fact_sheet.pdf.

National Environmental Policy Act of 1969 (NEPA), as amended. 42 USC 4321 *et seq.*

National Historic Preservation Act of 1966 (NHPA), as amended. 16 USC 470 *et seq.*

NRC (U.S. Nuclear Regulatory Commission). 1974. *Design Basis Tornado for Nuclear Power Plants*. Regulatory Guide 1.76, Revision 0, Washington, D.C. Accession No. ML003740273.

NRC (U.S. Nuclear Regulatory Commission). 1975. *Reactor Safety Study: An Assessment of Accident Risks in U.S. Commercial Nuclear Power Plants*. NUREG–75/014 (WASH–1400). Washington, D.C. Accession No. ML083570090.

NRC (U.S. Nuclear Regulatory Commission). 1976. *Flood Protection for Nuclear Plants*. Regulatory Guide 1.102, Washington, D.C. Accession No. ML003740308.

NRC (U.S. Nuclear Regulatory Commission). 1977. *Final Environmental Statement on Transportation of Radioactive Material by Air and Other Modes*. NUREG–0170, Volume 1, Washington, D.C. Accession No. ML12192A283.

NRC (U.S. Nuclear Regulatory Commission). 1984. *Environmental Assessment for 10 CFR Part 72 “Licensing Requirements for the Independent Storage of Spent Fuel and High-Level Radioactive Waste.”* NUREG–1092, Washington, D.C. Accession No. ML091050510.

NRC (U.S. Nuclear Regulatory Commission). 1989. *Regulatory Analysis for the Resolution of Generic Issue 82, “Beyond Design Basis Accidents in Spent Fuel Pools.”* NUREG–1353, Washington, D.C. Accession No. ML082330232.

NRC (U.S. Nuclear Regulatory Commission). 1991a. *Offsite Dose Calculation Manual Guidance: Standard Radiological Effluent Controls for Pressurized Water Reactors*. Generic Letter 89–01, Supplement No. 1, NUREG–1301, Washington, D.C. Accession No. ML091050061.

Environmental Impacts of At-Reactors Continued Storage of Spent Fuel

NRC (U.S. Nuclear Regulatory Commission). 1991b. *Offsite Dose Calculation Manual Guidance: Standard Radiological Effluent Controls for Boiling Water Reactors*. NUREG-1302, Generic Letter 89-01, Supplement No. 1, Washington, D.C. Accession No. ML031290469.

NRC (U.S. Nuclear Regulatory Commission). 1991c. *Environmental Assessment Related to Construction and Operation of the Calvert Cliffs Independent Spent Fuel Storage Installation*. Washington, D.C. Accession No. ML022550053.

NRC (U.S. Nuclear Regulatory Commission). 1991d. *Environmental Assessment Related to Construction and Operation of the Fort St. Vrain Independent Spent Fuel Storage Installation*. Washington, D.C. Accession No. ML062710252.

NRC (U.S. Nuclear Regulatory Commission). 1992. *Environmental Assessment Related to Construction and Operation of the Prairie Island Independent Spent Fuel Storage Installation*. Washington, D.C. Accession No. ML090260415.

NRC (U.S. Nuclear Regulatory Commission). 1996. *Generic Environmental Impact Statement for License Renewal of Nuclear Plants*. NUREG-1437, Washington, D.C. Available at <http://www.nrc.gov/reading-rm/doc-collections/nuregs/staff/sr1437/>.

NRC (U.S. Nuclear Regulatory Commission). 2000. *Radiological Consequence Analyses Using Alternative Source Terms*. Standard Review Plan. SRP-15.0.1, Revision 0. NUREG-0800, Washington, D.C. Accession No. ML003734190.

NRC (U.S. Nuclear Regulatory Commission). 2001. *Technical Study of Spent Fuel Accident Risk at Decommissioning Nuclear Power Plants*. NUREG-1738, Washington, D.C. Accession No. ML010430066.

NRC (U.S. Nuclear Regulatory Commission). 2002a. "Memorandum and Order in the Matter of Private Fuel Storage LLC (Independent Spent Fuel Storage Installation) [Environmental Justice Contention]." CLI-02-20, Washington, D.C. Accession No. ML022740427.

NRC (U.S. Nuclear Regulatory Commission). 2002b. *Final Generic Environmental Impact Statement for Decommissioning of Nuclear Facilities, Supplement 1 Regarding the Decommissioning of Nuclear Power Reactors*. NUREG-0586, Supplement 1, Volumes 1 and 2, Washington, D.C. Accession Nos. ML023470327, ML023500228.

NRC (U.S. Nuclear Regulatory Commission). 2003. *Environmental Assessment Related to the Construction and Operation of the Diablo Canyon Independent Spent Fuel Storage Installation*. Washington, D.C. Accession No. ML032970370.

Environmental Impacts of At-Reactor Continued Storage of Spent Fuel

NRC (U.S. Nuclear Regulatory Commission). 2004a. *Environmental Impact Statement for the Proposed Idaho Spent Fuel Facility at the Idaho National Engineering and Environmental Laboratory in Butte County, Idaho*. NUREG-1773, Washington, D.C. Accession No. ML040490135.

NRC (U.S. Nuclear Regulatory Commission). 2004b. "Memorandum and Order in the Matter of Private Fuel Storage LLC (Independent Spent Fuel Storage Installation) [Environmental Justice Contention]. CLI-04-09, Washington, D.C. Accession No. ML040840319.

NRC (U.S. Nuclear Regulatory Commission). 2004c. *Environmental Assessment for the License Renewal of the General Electric Morris Operation Independent Spent Fuel Storage Installation in Morris, Illinois*. Washington, D.C. Accession No. ML043360415.

NRC (U.S. Nuclear Regulatory Commission). 2005a. *Environmental Assessment Related to the Construction and Operation of the Humboldt Bay Independent Spent Fuel Storage Installation*. Washington, D.C. Accession No. ML052430106.

NRC (U.S. Nuclear Regulatory Commission). 2005b. *Environmental Assessment Related to the Renewal of the H.B. Robinson Steam Electric Plant, Unit No. 2 Independent Spent Fuel Storage Installation License, Special Nuclear Material License No. SNM-2502*. Washington, D.C. Accession No. ML050700137.

NRC (U.S. Nuclear Regulatory Commission). 2005c. *Environmental Assessment Related to the Renewal of the License for the Surry Independent Spent Fuel Storage Installation*. Washington, D.C. Accession No. ML040560238.

NRC (U.S. Nuclear Regulatory Commission). 2005d. Letter from L. Reyes to J. Wells, dated March 25, 2005, regarding "Draft Report, 'NRC Needs to Do More to Ensure that Power Plants are Effectively Controlling Spent Nuclear Fuel (GAO-05-339).'" Washington, D.C. Accession No. ML050690092.

NRC (U.S. Nuclear Regulatory Commission). 2006a. *Liquid Radioactive Release Lessons Learned Task Force Final Report*. Washington, D.C. Accession No. ML062650312.

NRC (U.S. Nuclear Regulatory Commission). 2006b. *Environmental Impact Statement for an Early Site Permit (ESP) at the Exelon ESP Site, Final Report*. NUREG-1815, Volume 1, Washington, D.C. Accession No. ML061930264.

NRC (U.S. Nuclear Regulatory Commission). 2006c. *Final Environmental Impact Statement for an Early Site Permit (ESP) at the North Anna ESP Site*. NUREG-1811, Volume 1, Washington, D.C. Accession No. ML063480261.

Environmental Impacts of At-Reactors Continued Storage of Spent Fuel

NRC (U.S. Nuclear Regulatory Commission). 2006d. Letter from M. Ryan to D. Klein, dated October 17, 2006, regarding "Probabilistic Risk Assessment of Dry Cask Storage of Spent Nuclear Fuel." Washington, D.C. Accession No. ML062900529.

NRC (U.S. Nuclear Regulatory Commission). 2007a. *Generic Environmental Impact Statement for License Renewal of Nuclear Plants, Supplement 29, Regarding Pilgrim Nuclear Power Station, Final Report*. NUREG-1437, Supplement 29, Volume 1, Washington, D.C. Accession No. ML071990020.

NRC (U.S. Nuclear Regulatory Commission). 2007b. *Standard Review Plan for the Review of Safety Analysis Reports for Nuclear Power Plants: LWR Edition*. NUREG-0800, Revision 6, Washington, D.C. Accession No. ML003734190.

NRC (U.S. Nuclear Regulatory Commission). 2007c. *Design-Basis Tornado and Tornado Missiles for Nuclear Power Plants*. Regulatory Guide 1.76, Revision 1, Washington, D.C. Accession No. ML070360253.

NRC (U.S. Nuclear Regulatory Commission). 2007d. *Seismic Design Classification*. Regulatory Guide 1.29, Revision 4, Washington, D.C. Accession No. ML070310052.

NRC (U.S. Nuclear Regulatory Commission). 2007e. *Quality Group Classifications and Standards for Water-, Steam-, and Radioactive-Waste-Contaminating Components of Nuclear Power Plants*. Regulatory Guide 1.26, Revision 4, Washington, D.C. Accession No. ML070290283.

NRC (U.S. Nuclear Regulatory Commission). 2007f. *A Pilot Probabilistic Risk Assessment of a Dry Cask Storage System at a Nuclear Power Plant*. NUREG-1864, Washington, D.C. Accession No. ML071340012.

NRC (U.S. Nuclear Regulatory Commission). 2007g. *Supplement to the Environmental Assessment and Final Finding of No Significant Impact Related to the Construction and Operation of the Diablo Canyon Independent Spent Fuel Storage Installation*. Washington, D.C. Accession No. ML072400511.

NRC (U.S. Nuclear Regulatory Commission). 2008a. *Generic Environmental Impact Statement for License Renewal of Nuclear Plants, Supplement 32 Regarding Wolf Creek Generating Station*. NUREG-1437, Supplement 32, Washington, D.C. Available at <http://www.nrc.gov/reading-rm/doc-collections/nuregs/staff/sr1437/supplement32/>.

NRC (U.S. Nuclear Regulatory Commission). 2008b. *Final Environmental Impact Statement for an Early Site Permit (ESP) at the Vogtle Electric Generating Plant Site*. NUREG-1872, Volume 1, Washington, D.C. Accession No. ML082240145.

Environmental Impacts of At-Reactor Continued Storage of Spent Fuel

NRC (U.S. Nuclear Regulatory Commission). 2008c. "Memorandum and Order in the Matter of Pacific Gas and Electric Co. (Diablo Canyon Power Plant Independent Spent Fuel Storage Installation)." CLI-08-01, Washington, D.C. Accession No. ML080150364.

NRC (U.S. Nuclear Regulatory Commission). 2009a. *Environmental Assessment for the Amendment of U.S. Nuclear Regulatory Commission License No. SNM-2506 for Prairie Island Independent Spent Fuel Storage Installation*. Washington, D.C. Accession No. ML093080494.

NRC (U.S. Nuclear Regulatory Commission). 2009b. *Environmental Assessment for the Renewal of U.S. Nuclear Regulatory Commission License No. SNM-2503 for Oconee Nuclear Station Independent Spent Fuel Storage Installation*. Washington, D.C. Accession No. ML091340557.

NRC (U.S. Nuclear Regulatory Commission). 2010. Memorandum from P. Hiland to B.W. Sheron, dated September 2, 2010, regarding "Safety/Risk Assessment Results for Generic Issue 199, 'Implications of Updated Probabilistic Seismic Hazard Estimates in Central and Eastern United States on Existing Plants.'" Washington, D.C. Accession No. ML100270582.

NRC (U.S. Nuclear Regulatory Commission). 2011a. *Final Environmental Impact Statement for the Combined License (COL) for Calvert Cliffs Nuclear Power Plant Unit 3*. NUREG-1936, Volumes 1 and 2, Washington, D.C. Accession Nos. ML11129A167, ML11129A179.

NRC (U.S. Nuclear Regulatory Commission). 2011b. *Senior Management Review of Overall Regulatory Approach to Groundwater Protection*. SECY-11-0019, Washington, D.C. Accession No. ML110050525.

NRC (U.S. Nuclear Regulatory Commission). 2011c. *Final Environmental Impact Statement for the Combined Licenses (COLs) for Virgil C. Summer Nuclear Station, Units 2 and 3*. NUREG-1939, Volumes 1 and 2, Washington, D.C. Accession Nos. ML11098A044, ML11098A057.

NRC (U.S. Nuclear Regulatory Commission). 2011d. *Final Environmental Impact Statement for the Combined Licenses (COLs) for South Texas Project Electric Generating Station Units 3 and 4*. NUREG-1937, Washington, D.C. Accession No. ML11049A000.

NRC (U.S. Nuclear Regulatory Commission). 2011e. *Fact Sheet on Seismic Issues for Nuclear Power Plants*. Washington, D.C. Accession No. ML081620327.

NRC (U.S. Nuclear Regulatory Commission). 2011f. *Design-Basis Hurricane and Hurricane Missiles for Nuclear Power Plants*. Regulatory Guide 1.221, Revision 0, Washington, D.C. Accession No. ML110940300.

Environmental Impacts of At-Reactor Continued Storage of Spent Fuel

NRC (U.S. Nuclear Regulatory Commission). 2012a. *Environmental Assessment for the Proposed Renewal of U.S. Nuclear Regulatory Commission License No. SNM-2505 for Calvert Cliffs Nuclear Power Plant, LLC's Independent Spent Fuel Storage Installation*. Washington, D.C. Accession No. ML121220084.

NRC (U.S. Nuclear Regulatory Commission). 2012b. *Occupational Radiation Exposure at Commercial Nuclear Power Reactors and Other Facilities 2010: Forty-Third Annual Report*. NUREG-0713, Volume 32, Washington, D.C. Available at <http://www.nrc.gov/reading-rm/doc-collections/nuregs/staff/sr0713/v32/>.

NRC (U.S. Nuclear Regulatory Commission). 2012c. *Central and Eastern United States Seismic Source Characteristics for Nuclear Facilities*. NUREG-2115, Washington, D.C. Accession No. ML12048A776.

NRC (U.S. Nuclear Regulatory Commission). 2012d. *Request for Information Pursuant to Title 10 of the Code of Federal Regulations 50.54(f) Regarding Recommendations 2.1, 2.3, and 9.3 of the Near-Term Task Force Review of Insights From the Fukushima Dai-Ichi Accident*. Washington, D.C. Accession No. ML12053A340.

NRC (U.S. Nuclear Regulatory Commission). 2013a. *Generic Environmental Impact Statement for License Renewal of Nuclear Plants*. NUREG-1437, Revision 1, Washington, D.C. Accession No. ML13107A023.

NRC (U.S. Nuclear Regulatory Commission). 2013b. *Environmental Impact Statement for the Combined License (COL) for Enrico Fermi Unit 3 Final Report*. NUREG-2105, Volumes 1 and 2, Washington, D.C. Accession Nos. ML12307A172, ML12307A176.

NRC (U.S. Nuclear Regulatory Commission). 2013c. *Attachment 1—Staff Guidance for Greenhouse Gas and Climate Change Impacts for New Reactor Environmental Impact Statements*. COL/ESP-ISG-026, Washington, D.C. Accession No. ML12326A811.

NRC (U.S. Nuclear Regulatory Commission). 2013d. *Final Environmental Impact Statement for Combined Licenses for William States Lee III Nuclear Station Units 1 and 2*. NUREG-2111, Volumes 1 and 2, Washington, D.C. Accession Nos. ML13340A005, ML13340A006, ML13340A007.

NRC (U.S. Nuclear Regulatory Commission). 2013e. *Generic Issue Management Control System Report for Fiscal Year 2013 1st Quarter*. Washington, D.C. Accession No. ML13007A492.

Environmental Impacts of At-Reactor Continued Storage of Spent Fuel

Pacific Gas and Electric Company. 2012. Letter from Pacific Gas and Electric Company to NRC, dated December 17, 2012, regarding “Diablo Canyon Independent Spent Fuel Storage Installation - Decommissioning Funding Plan.” Avila Beach, California. Accession No. ML12353A315.

Prasad, R., L. Hibler, A. Coleman, and D. Ward. 2011. *Design-Basis Flood Estimation for Site Characterization at Nuclear Power Plants in the United States of America*. NUREG/CR-7046, Pacific Northwest National Laboratory, Richland, Washington. Accession No. ML11321A195.

Resource Conservation and Recovery Act of 1976 (RCRA). 42 USC 6901 *et seq.*

Safe Drinking Water Act, as amended. 42 USC 300f *et seq.*

San Luis Obispo Mothers for Peace v. NRC (Nuclear Regulatory Commission). 635 F.3d 1109 (9th Cir. 2011).

Transnuclear, Inc. 2004. *Standardized NUHOMS® Horizontal Modular Storage System for Irradiated Nuclear Fuel*. Final Safety Analysis Report, Volume 3 of 4, Appendix M, Hawthorne, New York. Accession No. ML051040570.

Washington State Department of Transportation. 2014. *Biological Assessment Preparation for Transportation Projects – Advanced Training Manual – Version 2014*. Olympia, Washington. Available at <http://www.wsdot.wa.gov/Environment/Biology/BA/BAguidance.htm>.

5.0 Environmental Impacts of Away-From-Reactor Storage

This chapter evaluates the environmental impacts of continued away-from-reactor storage of spent nuclear fuel (spent fuel) in an independent spent fuel storage installation (ISFSI) beyond the licensed life for operation of a reactor during the timeframes considered in this *Generic Environmental Impact Statement for Continued Storage of Spent Nuclear Fuel* (GEIS).

No away-from-reactor ISFSIs of the size considered in this chapter have been constructed in the United States; however, the U.S. Nuclear Regulatory Commission (NRC) has issued a license to Private Fuel Storage, LLC (PFS) to construct and operate the Private Fuel Storage Facility (PFSF) on the Reservation of the Skull Valley Band of Goshute Indians in Tooele County, Utah (NRC 2006a).¹

For the purposes of evaluating the environmental impacts of continued storage of spent fuel at an away-from-reactor ISFSI, the NRC evaluates the impacts of a facility of the same size as the proposed PFS ISFSI. To perform this evaluation, the NRC makes the following assumptions:

- The ISFSI would have the same capacity as that analyzed for the PFSF, which was designed to store up to 40,000 MTU of spent fuel. This amount of spent fuel is more than half of the amount generated to date by commercial reactors in the United States, and more than twice as much as the amount in dry storage based on the most recent data (NRC 2013a). The amount of fuel storage (40,000 MTU) evaluated for the away-from-reactor ISFSI would represent all of the spent fuel from multiple reactor sites.
- The ISFSI would be of approximately the same physical size as that analyzed for the PFSF, which would have been built on a fenced 330-ha (820-ac) site; the actual storage facilities would have been built on a 40-ha (99-ac) portion of the site. The onsite facilities (e.g., buildings and storage pads) for the ISFSI would be similar to those for the PFSF. This aligns with the preceding assumption.

¹ Although a license was issued, the PFSF has not yet been constructed. However, the NRC determined based on its review of the application that there is reasonable assurance that if the PFSF is constructed: (i) the activities authorized by the license can be conducted without endangering the health and safety of the public; and (ii) these activities will be conducted in compliance with the applicable regulations of 10 CFR Part 72 (NRC 2006a). See also Appendix B, Section B.3.2.2, of this GEIS. In addition, the U.S. Department of Energy has indicated that a storage facility of this type is part of its plan to respond to the recommendations of the “Blue Ribbon Commission on America’s Nuclear Future” (DOE 2013).

Environmental Impacts of Away-From-Reactor Storage

- The ISFSI would require a dry transfer system (DTS) similar to that described in Section 2.1.4 of this GEIS for the long-term storage and indefinite storage timeframes. The DTS is assumed to be built sometime after the ISFSI is built because it would not be needed immediately.
- Construction and operation of the ISFSI would be similar to that analyzed for the PFSF and would require workforces similar in size to those described for the PFSF, consistent with the first assumption above.
- No specific location is used by the NRC in the evaluation of an away-from-reactor ISFSI. However, the location of the ISFSI would be chosen to meet the siting evaluation factors in Title 10 of the *Code of Federal Regulations* Part 72, Subpart E (10 CFR Part 72, Subpart E). For example, a site would be deemed unsuitable if adequate protection cannot be provided for design basis external events. The NRC would also consider characteristics such as population density, seismicity, and flooding potential as part of its evaluation of a proposed ISFSI site.
- In most instances, placement of facilities on a proposed site could be adjusted to minimize or avoid impacts on water, ecological, historic and cultural, and other resources in the area; however, the NRC recognizes that this is not always possible. Because an away-from-reactor ISFSI does not depend on a significant water supply and has limited electrical power needs, an applicant may have more flexibility in how it chooses to place facilities on a site and, therefore, a greater chance of avoiding impacts to resources in the area.

The NRC believes that these assumptions are reasonable and provide an acceptable basis for developing a generic evaluation of away-from-reactor storage of spent fuel. The NRC makes no assumptions about when the ISFSI might be built. While the NRC assumes that any proposed away-from-reactor ISFSI would likely be similar to the assumed generic facility described above from the standpoint of the size, operational characteristics, and location of the facility, the NRC would evaluate the site-specific impacts of the construction and operation of any proposed facility as part of that facility's licensing process. This review would not reanalyze the impacts of continued storage of the spent fuel, but would incorporate the impact determinations of this GEIS, as stated in 10 CFR 51.23(b). In this chapter, the term ISFSI refers to all of the original facilities that would be built (i.e., storage pads, casks, and canister transfer building), and the DTS is addressed separately because the NRC assumes that it would be added after the ISFSI would be placed into operation.

In addition to the assumptions discussed above, the analysis of the environmental impacts of an away-from-reactor ISFSI are based, in general, on the description of the affected environment provided and discussed in Sections 3.1 through 3.16 for at-reactor spent fuel storage. However, some aspects of the discussions are not applicable, or are not applicable in the same way, for an away-from-reactor ISFSI. The NRC analysis will be based on the following differences:

Environmental Impacts of Away-From-Reactor Storage

- Portions of the discussion of at-reactor spent fuel storage address facilities that are in semi-urban areas. However, the NRC assumes that an away-from-reactor ISFSI will be built in an area of low population density.
- Portions of the discussion of at-reactor spent fuel storage start from an assumption that socioeconomic conditions and infrastructure (e.g., access roads) have been established prior to the short-term storage timeframe due to the presence of an existing nuclear power plant. For an away-from-reactor ISFSI, the NRC assumes conditions typical in remote areas (e.g., limited pre-existing road infrastructure).
- Portions of the discussion of at-reactor spent fuel storage start from an assumption that certain site conditions (e.g., proximity to major waterbodies and associated historic and cultural resources) are related to the way nuclear power plants are sited. Those conditions likely would not be applicable to an away-from-reactor ISFSI. For an away-from-reactor ISFSI, the NRC assumes that the site selection would be adjusted to minimize impacts on local resources, including historic and cultural resources and special status species and habitats, while acknowledging that in some cases avoiding impacts may not be possible.
- Portions of the discussion of at-reactor spent fuel storage assume pre-existing programs associated with operating reactors (e.g., radiological environmental monitoring program and monitoring for decommissioning) that would exist in a somewhat different form for an away-from-reactor ISFSI. For an away-from-reactor facility, the NRC bases its evaluation of the impacts of public and occupational doses on the limits and radiological monitoring requirements in 10 CFR Part 72 and 10 CFR Part 20 that are applicable to an away-from-reactor ISFSI.
- Portions of the discussion of at-reactor spent fuel storage focus on issues related to reactor plant systems (e.g., cooling-water systems, liquid and gaseous radioactive waste, and transmission lines), which would not be applicable for an away-from-reactor ISFSI. For an away-from-reactor facility, the NRC bases its evaluation of impacts on the systems and supporting facilities that are expected at such an installation.

With these exceptions, the NRC used the descriptions of the affected environment in Sections 3.1 through 3.16 in its evaluation of the environmental impacts of an away-from-reactor ISFSI.

Major features of the away-from-reactor ISFSI include the canister transfer building, the DTS, the storage casks, and the storage pads. The canister transfer building is used to receive transportation packages and to move spent fuel canisters from the transportation packages to storage casks for movement to the pads. The building would also be used to move spent fuel canisters from the storage casks into transportation packages for the shipment of the spent fuel to the repository. The canister transfer building would be used in the early years and toward the end of the ISFSI's operational period, recognizing that the shipment of the fuel from the reactors

Environmental Impacts of Away-From-Reactor Storage

to the ISFSI might occur over a period of 20 or more years. Shipment of the fuel from the ISFSI to the repository would occur over a similar timeframe. The DTS is designed to handle spent fuel outside the storage canister (i.e., to move the fuel into a new canister if monitoring identifies the need to replace the old canister). The DTS is used on an as-needed basis and would likely be built sometime after the ISFSI begins operations and would be used over the life of the ISFSI.

The potential impacts from transportation of spent fuel from an away-from-reactor ISFSI to a repository are evaluated in Chapter 6 as part of cumulative impacts. Transportation of spent fuel to an away-from-reactor storage facility is evaluated in Section 5.16.

The NRC does not evaluate the impacts of decommissioning of the away-from-reactor ISFSI and DTS in this chapter. The impacts of these activities are considered in the cumulative impacts analysis in Chapter 6.

For the short-term storage timeframe (see Section 1.8.2), the NRC evaluates the impacts of continued storage of spent fuel for 60 years beyond the licensed life for operations of a reference reactor. The NRC assumes that a repository would become available by the end of this 60-year timeframe.

Short-term storage of spent fuel for 60 years beyond licensed life for operations at an away-from-reactor ISFSI includes the following:

- construction and continued operation of the ISFSI,
- routine maintenance and monitoring of the ISFSI, and
- cask handling and transfers.

For the long-term storage timeframe, the NRC evaluates the impacts of continued storage for another 100 years after short-term storage. The NRC assumes that a repository would become available by the end of this 100-year timeframe and that the oldest fuel would be transferred to the repository first.

Long-term storage activities include the following:

- continued operation and routine maintenance and monitoring of the away-from-reactor ISFSI,
- construction and operation of a DTS², and

² A licensee would have to request authorization from the NRC to build and operate the DTS, either during initial licensing of the ISFSI, or as a later, separate action. As part of its review of such a request, the NRC would have to consider any associated environmental impacts under 10 CFR Part 51.

- one-time replacement of the ISFSI (i.e., replacement of casks and canisters, concrete pads, and canister transfer building) and the DTS (see Section 1.8.2).

For the indefinite storage timeframe, the NRC has also evaluated the environmental consequences within each resource area for a scenario assuming a repository does not become available, thus requiring indefinite onsite storage. Although the NRC believes that this scenario is highly unlikely (see Section 1.2 of this GEIS), impact determinations for indefinite storage and fuel handling at an away-from-reactor ISFSI have been made for each resource area. The activities associated with indefinite storage are the same as those for the long-term storage timeframe, except that they would occur repeatedly due to the lack of a repository. As discussed in Chapter 1, the ISFSI (i.e., casks and canisters, concrete pads, and canister transfer building) and the DTS would be replaced on a 100-year cycle.

Sections 5.1 through 5.19 evaluate potential impacts on various resource areas, such as land use, air quality, and water quality. Within each resource area, the NRC provides an analysis of the potential impacts and an impact determination – SMALL, MODERATE, LARGE – for each timeframe. For some resource areas, the impact determination language is specific to the authorizing regulation, executive order, or guidance.

5.1 Land Use

This section describes land-use impacts caused by the continued storage of spent fuel at an away-from-reactor ISFSI.

5.1.1 Short-Term Storage

The environmental impacts on land use from the construction and operation of an away-from-reactor storage facility are based on a facility similar to the PFSF (NRC 2001), built at a location selected based on the assumptions presented above. The ISFSI would be designed to store up to 40,000 MTU of spent fuel on a fenced 330-ha (820-ac) site. Storage pads for the canisters and some support facilities would be located on a 40-ha (99-ac) restricted access area within the site.

Construction activities associated with the ISFSI would be limited to the immediate area of the ISFSI site and would primarily consist of clearing, excavation, and grading of the 40-ha (99-ac) restricted access area where the storage pads and major buildings would be located. In addition, one or more access roads and a rail spur would likely have to be either built or improved. Based on its past experience and judgment, the NRC assumes that (1) disturbed areas around the ISFSI site and associated corridors would be graded and reseeded after

Environmental Impacts of Away-From-Reactor Storage

construction is completed, (2) permits³ would require best management practices (BMPs) such as construction of flood diversion berms to control erosion and the installation of silt fencing and sediments traps to stabilize disturbed soils to reduce land-use impacts, and (3) the 40-ha (99-ac) restricted access area would be enclosed with chain-link security fencing. For the PFSF, the total amount of land disturbed for construction, including the access road and rail line, was 408 ha (1,008 ac) and the rail line represented more than three-quarters of the land disturbed. Of the land disturbed, 288 ha (713 ac) was to be revegetated after construction and 120 ha (295 ac) was expected to remain cleared; the rail line represented more than half of that value (NRC 2001). Although these numbers are specific to the PFSF analysis, based on the assumptions presented in the introduction to this chapter, they provide a reasonable representation of the amount of land disturbance that could be expected at another location because the rail line was fairly long at 51 km (32 mi).

Construction of any proposed ISFSI would change the nature of land use within the site boundary and along the access corridors. While this change would be qualitatively substantial (e.g., from agricultural to industrial), the land parcel is assumed to be sufficiently remote and relatively small (compared, for example, to any surrounding county) so that no quantitatively significant impact would occur. By way of comparison, for the proposed Levy Nuclear Plant, the NRC concluded that the land-use impacts for the plant (not including transmission lines) “would not noticeably alter the existing land uses within the vicinity and region.” The Levy project (not including transmission lines) would have affected just over 405 ha (1,000 ac) (NRC 2012).

Operation of any proposed ISFSI would involve transportation of spent fuel from reactors to the ISFSI and receiving, transferring, and storing the spent fuel. Impacts on land use during ISFSI operations would create no additional impacts on land use beyond those for the construction of the facility. This generic analysis and associated findings are consistent with the findings for the PFSF (NRC 2001).

Based on its review, the NRC concludes that the impacts on land use from the construction and operation of an away-from-reactor ISFSI would be SMALL. This is because the land parcel for the ISFSI is assumed to be remote and relatively small.

5.1.2 Long-Term Storage

As discussed in the introduction to this chapter, the NRC assumes that a DTS is constructed as part of an away-from-reactor ISFSI. The NRC also assumes that the DTS will be built inside the confines of the ISFSI’s 40-ha (99-ac) restricted area—a reasonable assumption considering the small area (0.04 ha [0.1 ac]) required for the DTS basemat and 0.7 ha (2 ac) for the DTS security zone. The DTS would be used to facilitate transfer of the spent fuel canister from one

³ For example, the licensee of each site would have to obtain a National Pollutant Discharge Elimination System permit that would include requirements to minimize the impacts of stormwater runoff.

cask to another, retrieve and repackage spent fuel, or replace damaged canisters or casks identified during visual inspections. Construction and operation of a DTS at an away-from-reactor ISFSI would be based on Section 2.1.4 of this GEIS.

By comparison, the canister transfer building at the PFSF would have been a fully enclosed high-bay building equipped with cask transfer and handling equipment (e.g., overhead and gantry cranes) and radiation-shielded transfer cells for transferring the spent fuel canisters from transportation packages to the storage casks (NRC 2001). The building would have occupied about 0.5 ha (1.2 ac) within the 40-ha (99-ac) restricted access area where the storage pads, major buildings, and access roads would have been located (NRC 2001). It is possible such a building would be equipped or could be retrofitted with the necessary equipment for retrieval and repackaging of spent fuel. However, for the purposes of the analysis in this GEIS, the NRC assumes that a separate DTS will be constructed.

The NRC assumes that construction of a DTS would take 1 to 2 years based on a construction schedule similar to that for the canister transfer building at the PFSF, which was estimated to take approximately 18 months (NRC 2001). Construction equipment would be used to grade and level the DTS site and excavate the facility foundation. Construction of the DTS structures would disturb about 0.04 ha (0.1 ac) of land. In addition, the NRC expects that land adjacent to a DTS would be disturbed for a construction laydown area. Based on its past experience and judgment, the NRC assumes that after the construction of the DTS is completed (i.e., about 1 to 2 years), the construction laydown area would be reclaimed and revegetated. The DTS would be built within an area for which access is already restricted, and it would represent a small increase in the amount of land that is disturbed within that restricted area.

The NRC also assumes that aging management would require the replacement of an away-from-reactor ISFSI and DTS (i.e., the concrete storage casks and concrete storage pads, and canister transfer building) during the long-term timeframe. Replacement facilities would be constructed on land near the existing facilities. The old facilities would be demolished and the land reclaimed. Regardless, this land would be inside the 40-ha (99-ac) restricted area and it would be unavailable for other uses for as long as the ISFSI exists.

In conclusion, construction of a DTS would disturb a small portion of the land committed for an away-from-reactor ISFSI. Operational impacts would include continuing to restrict access to the facility site and use of the site for spent fuel transfer, handling, repackaging, and aging management activities. To minimize land-use impacts from replacing storage casks, storage pads, the canister transfer building, and the DTS, replacement facilities would likely be constructed on land near the existing facilities. Therefore, the NRC concludes that the impact on land use from long-term storage of spent fuel at an away-from-reactor ISFSI would be SMALL.

5.1.3 Indefinite Storage

This section describes the potential environmental impacts on land use if a repository is not available to accept spent fuel. For this analysis, the NRC assumes that spent fuel would continue to be stored at an away-from-reactor ISFSI indefinitely.

The environmental impacts on land use from continued operation of dry cask storage of spent fuel at an away-from-reactor ISFSI if a repository is not available would be similar to those described in Section 5.1.2. All operations and maintenance activities would occur inside the 40-ha (99-ac) restricted area, which would remain unavailable for other uses for as long as the ISFSI exists. These activities would occur repeatedly because the spent fuel would remain at the facility indefinitely.

In conclusion, continued storage of spent fuel in an away-from-reactor ISFSI indefinitely (i.e., if a repository is not available) would affect only a small portion of the total land area developed for the storage facility and would not change land-use conditions. Therefore, the NRC concludes that the environmental impacts on land use from indefinite storage of spent fuel at an away-from-reactor ISFSI would be SMALL.

5.2 Socioeconomics

This section describes socioeconomic impacts caused by the continued storage of spent fuel at an away-from-reactor ISFSI. Several types of impacts could occur, including impacts on economy, housing, and public services.

As discussed in Section 5.0, should the NRC receive an application for a proposed away-from-reactor ISFSI, the NRC would evaluate the site-specific impacts of the construction and operation of any proposed facility as part of that facility's licensing process. This review would consider impacts to socioeconomic conditions, including specific concerns attributable to the special conditions within a community.

5.2.1 Short-Term Storage

Construction activities would be temporary and would occur mainly within the boundaries of the ISFSI site. As discussed in the introduction to this chapter, the NRC used the characteristics of the PFSF (e.g., land area affected and size of workforce) in its analyses. There would be incremental changes to offsite services to support construction activities, such as the transportation of construction materials. Most of the construction workforce (255 workers at its peak) is expected to come from within the region, and those workers who might relocate to the region would represent a small percentage of the surrounding area's population base. Because of the relatively short duration of the construction project, few, if any, of the workers who migrate to work at the site would be accompanied by their families. As a result, the impacts on housing

and public services are expected to be minor. Aside from the direct impacts associated with the project, there would also be indirect impacts from jobs created in the area. For example, the purchase of goods by workers onsite and in the local community could create additional jobs. However, unlike jobs associated directly with the construction of the ISFSI, indirect jobs are more likely to be filled by local residents. Given the small number of construction workers, there would not be a noticeable increase in the demand for housing and public services. The economic impact on the local and regional economy would be minor.

During ISFSI operation, employees would continue to maintain, monitor, and inspect the facility. The NRC estimates that the number of operations workers would be around 43 based on the PFSF environmental impact statement (EIS) (NRC 2001). In contrast to construction, for which workers may or may not relocate, workers employed for the operation of the storage facility, if they were not from the local area, would be expected to move into the area with their families. Given the small number of operations workers, there would not be a noticeable increase in the demand for housing and public services. The impacts on the local and regional economy would be minor.

Local and State government agencies would receive tax payments from the ISFSI licensee. The impact of the payments would depend on a number of factors, including the pre-existing economic conditions. If the local jurisdiction(s) already have a substantial tax base, then the addition of taxes from the ISFSI would have a minor beneficial impact. But if the pre-existing local tax base was small, then the new tax revenue could have a significant beneficial impact. For the PFSF, the NRC concluded that there would be a large impact on the Skull Valley Band and on Tooele County from the payments made by PFS (NRC 2001). Based on the assumption that any away-from-reactor ISFSI would be built in an area with low population density, the NRC concludes that the increase in tax revenue could have a significant beneficial impact on the local economy, but the beneficial impacts beyond the host jurisdiction would be minor.

In the PFSF EIS, the NRC concluded that construction and operation of an away-from-reactor ISFSI would have a SMALL socioeconomic impact (NRC 2001). Considering the very sparse population around the PFS site (30 persons on the Reservation and a total of about 150 persons in all of Skull Valley), the NRC concludes that the socioeconomic impacts at any site of constructing and operating an away-from-reactor ISFSI would be similar to those described in the PFSF EIS. Based on the analysis above, construction and operation of an away-from-reactor ISFSI could generate potentially LARGE beneficial economic impacts in some rural economies as well as SMALL adverse socioeconomic impacts due to increased demand for housing and public services.

5.2.2 Long-Term Storage

A DTS constructed as part of an away-from-reactor ISFSI would be used to facilitate the replacement of spent fuel canisters as part of aging management practices. The construction of

Environmental Impacts of Away-From-Reactor Storage

the DTS would require a workforce smaller than that required for construction of an away-from-reactor ISFSI. Similar to the construction of the ISFSI, the workers would come from a combination of the existing workforce or commute into the area from surrounding communities, but workers would be unlikely to move into the area for DTS construction due to the short duration of the project. Therefore, the impacts from the construction of the DTS are bounded by those associated with the construction of the ISFSI discussed in Section 5.2.1.

A staged approach to aging management would require the replacement of an away-from-reactor ISFSI (i.e., the concrete storage casks, concrete storage pads, and canister transfer building) and replacement of the DTS during the long-term storage timeframe. The workforce required for the replacement of these structures and components would be similar to or less than the workforce required for the original construction of the ISFSI, depending on how the work is spread out over time. Therefore, the socioeconomic impacts of these workers would be similar to or less than the impacts of the original construction of the ISFSI. In addition, the operational and maintenance activities begun during the short-term timeframe would continue, as would the tax payments to local jurisdictions.

As discussed above, the impacts from long-term operation and maintenance of the ISFSI are bounded by those described in Section 5.2.1. Therefore, the NRC concludes the socioeconomic impacts on public services and housing from continued storage during the long-term timeframe would be SMALL. Beneficial impacts from property-tax payments could be LARGE in some rural economies.

5.2.3 Indefinite Storage

This section evaluates the socioeconomic impacts of away-from-reactor storage assuming a repository does not become available. The same operations and maintenance activities described in Section 5.2.2 occur repeatedly because the spent fuel remains at the facility indefinitely. Therefore, the NRC concludes that the socioeconomic impacts on public services and housing during the indefinite timeframe would be SMALL. Beneficial impacts from property-tax payments could be LARGE in some rural economies.

5.3 Environmental Justice

This section describes the potential human health and environmental effects on minority and low-income populations caused by the continued storage of spent fuel at an away-from-reactor ISFSI. See Sections 3.3 and 4.3 for discussion of the approach the NRC uses to evaluate issues related to environmental justice. The discussion in both sections is also applicable to the consideration of environmental justice for an away-from-reactor ISFSI. As explained in Section 4.3, the NRC strives to identify and consider environmental justice issues in agency licensing

and regulatory actions primarily by fulfilling its National Environmental Policy Act of 1969, as amended (NEPA) responsibilities for these actions.

In most cases, the NRC environmental justice analyses are limited to evaluating the human health effects of the proposed licensing action and the potential for minority and low-income populations to be disproportionately affected. As explained in the Commission's policy statement, issues related to environmental justice and demographic conditions (i.e., the presence of potentially affected minority and low-income populations) differ from site to site, and environmental justice issues and concerns usually cannot be resolved generically. In site-specific licensing actions, the NRC addresses environmental justice issues and concerns during environmental reviews by identifying potentially affected minority and low-income populations. Then, the NRC determines whether there would be any potential human health or environmental effects and whether these effects may be disproportionately high and adverse. Human health and environmental effects are defined in Section 3.3. Consequently, environmental justice, as well as other socioeconomic issues, is normally considered in site-specific environmental reviews (69 FR 52040). However, the NRC has determined that for the purposes of this GEIS a generic analysis of the human health and environmental effects of continued storage from the construction and operation of an away-from-reactor ISFSI on minority and low-income populations is possible. In addition, should the NRC receive an application for a proposed away-from-reactor ISFSI, a site-specific NEPA analysis would be conducted which would include consideration of environmental justice.

As previously stated in Chapters 2 and 3, this GEIS and the Rule are not licensing actions and do not authorize the continued storage of spent fuel. The environmental analysis in this GEIS fulfills a small part of the NRC's NEPA obligation with respect to the licensing or relicensing of an away-from-reactor ISFSI. Further, for site-specific licenses, the NEPA analysis would include consideration of environmental justice prior to any NRC licensing action. As with other resource areas, this site-specific analysis allows the NRC to make an impact determination for each NRC licensing action. For the purposes of this GEIS, a generic determination of the human health and environmental effects during continued storage at an away-from-reactor ISFSI is possible because the NRC understands how such a facility will be sited.

5.3.1 Short-Term Storage

The construction and short-term operation of an away-from-reactor ISFSI could raise environmental justice concerns. Should the NRC receive an application for a proposed away-from-reactor ISFSI, a site-specific NEPA analysis would be conducted, and this analysis would include consideration of environmental justice impacts per the Commission's policy statement.

During the environmental review for a proposed site-specific away-from-reactor ISFSI, the NRC would collect demographic information about nearby minority and low-income populations and any special characteristics (e.g., subsistence fishing) of those populations. The NRC would

Environmental Impacts of Away-From-Reactor Storage

collect this information to evaluate the potential for disproportionately high and adverse human health and environmental effects on those populations. During the PFSF review, the NRC concluded that “no disproportionately high and adverse impacts will occur to the Skull Valley Band or to minority and low-income populations living near the proposed rail routes from the proposed action” (NRC 2001).

For the analysis in this GEIS, it is not possible to define the characteristics of minority or low-income populations around a potential away-from-reactor ISFSI and associated transportation corridors. However, environmental justice would be one of the factors considered in the siting and licensing of any ISFSI. Using past licensing experience as an indicator, disproportionately high and adverse impacts on minority or low-income populations could be avoided through the siting process. If impacts were determined to be disproportionately high and adverse, the facility could be relocated or plans modified to mitigate any adverse effects. For example, the Louisiana Energy Services facility was originally proposed for a location in Louisiana. However, the applicant eventually decided to withdraw its application (LES 1998, NRC 1998) and select a different site for its facility. A key outstanding issue for the project was an environmental justice concern identified during the licensing review.

Potential impacts to minority and low-income populations from the construction and operation of an away-from-reactor ISFSI would mostly consist of environmental and socioeconomic effects (e.g., noise, dust, traffic, employment, and housing impacts). Noise and dust impacts from construction would be short-term and primarily limited to onsite activities. Minority and low-income populations residing along site access roads would be affected by increased commuter vehicle traffic during shift changes and truck traffic. However, these effects would be temporary during certain hours of the day and would not likely be high and adverse. Increased demand for rental housing during construction could disproportionately affect low-income populations. However, construction workers could commute to the site, thereby reducing the potential demand for rental housing.

Regarding visual impacts, the NRC expects the canister transfer building to be the largest building on the site. For the PFSF, this building would have been approximately 60 m (200 ft) wide, 80 m (260 ft) long, and 27 m (90 ft) high (NRC 2001). Using the 330-ha (820-ac) site area for the PFSF as a guide, the site boundary would be approximately 0.8 km (0.5 mi) from the facility. At this distance the NRC concludes that visual impacts on nearby residents would be minimal. Depending on the location of minority or low-income populations, these populations could experience an adverse impact. As stated in Section 5.14, impacts could range from SMALL to MODERATE. However, impacts are not expected to be disproportionately high and adverse.

As discussed in Section 5.12, in most instances, placement of facilities on a proposed site could be adjusted to minimize or avoid impacts on historic and cultural resources in the area, but the NRC recognizes that this is not always possible. The magnitude of adverse effects on historic

properties and impacts on historic and cultural resources largely depends on where the facilities are sited, what resources are present, the extent of proposed land disturbance, and if the licensee has management plans and procedures that are protective of historic and cultural resources. The NRC's site-specific environmental review and compliance with the National Historic Preservation Act (NHPA) process could identify historic properties, adverse effects, and potentially resolve adverse effects on historic properties and impacts on other historic and cultural resources. As discussed in Section 3.3, a disproportionately high and adverse environmental impact refers to an impact or risk of an impact on the natural or physical environment in a low-income or minority community that appreciably exceeds the environmental impact on the larger community. In assessing cultural environmental impacts, impacts that uniquely affect minority or low-income populations or American Indian tribes are also considered. Thus, the potential impacts on historic and cultural resources could be SMALL to LARGE depending on site-specific factors.

Regarding noise, in Section 5.13 the NRC concludes that impacts near the site could exceed U.S. Environmental Protection Agency (EPA)-recommended levels at times during construction and operations. If minority or low-income populations are located near the site boundary or transportation routes, they could be disproportionately affected; although the NRC concluded in Section 5.13 that the overall noise impacts could be SMALL. Therefore, the NRC does not expect that these impacts would be disproportionately high and adverse.

Radiation doses to surrounding populations would be maintained within regulatory limits (as provided in 10 CFR Part 20), ensuring minor impacts. In addition, the licensee is required by 10 CFR 72.44(d)(2) to implement an environmental monitoring program to ensure compliance with effluent limitations. Based on a review of recent radiological environmental monitoring program reports, human health impacts would not be expected in special pathway receptor populations living near a nuclear power plant as a result of subsistence consumption of water, local food, fish, or wildlife during continued storage of spent fuel. Unlike the operation of nuclear reactors, the operation of the ISFSI is not expected to have any routine radiological effluents. Therefore, the results for reactors bound the results for the away-from-reactor ISFSI, and the NRC concludes that there would not be any disproportionately high and adverse radiological human health or environmental impacts on any minority or low-income populations in the area.

Siting of an away-from-reactor ISFSI would be expected to ensure that environmental justice concerns are addressed prior to licensing. As discussed for the other resource areas, overall human health and environmental effects from construction and from the continued storage of spent fuel during the short-term timeframe would be limited in scope and SMALL for all populations, except for air quality, terrestrial resources, aesthetics, historic and cultural resources, and socioeconomic and traffic conditions. Short-term storage impacts to each of the affected resource areas are discussed elsewhere in this chapter. Based on this information and the analysis of human health and environmental impacts discussed for other resource areas in

Environmental Impacts of Away-From-Reactor Storage

this chapter, minority and low-income populations are not expected to experience disproportionately high and adverse human health or environmental effects from the construction and operation of an away-from-reactor ISFSI during the short-term timeframe.

5.3.2 Long-Term Storage

The construction of a DTS would occur within the facility boundaries. NRC authorization to construct and operate a DTS and replace the ISFSI and DTS would constitute Federal actions under the NEPA and would be addressed through site-specific reviews that would include an analysis of the potential human health and environmental effects on minority and low-income populations. The environmental review for the DTS would not rely on the analysis in this GEIS, because the site-specific NEPA analysis would consider the site-specific impacts on minority and low-income populations.

Impacts from construction of the DTS would include the potential for an increase in labor demand similar to that described under the initial construction of the away-from-reactor facility, although on a somewhat smaller scale (60 to 80 workers, see Sections 4.2.2 and 4.3.2). The activities associated with building an away-from-reactor ISFSI are described in the PFSF EIS (NRC 2001). Because building the DTS is a much smaller project and would occur within the ISFSI protected area, the description from the PFSF EIS activities bound the activities necessary to build the DTS. Therefore, the NRC concludes that the impacts from construction of the DTS would be bounded by the impacts from the construction of the away-from-reactor ISFSI, as discussed in Section 5.3.1.

Aging management would include continued monitoring, maintenance, and a staged approach to replacement of ISFSI facilities and components (i.e., casks, pads, and canister transfer building) and the DTS. Activities associated with aging management are described in Sections 4.1.2, 4.15.2, and 5.1.2. These activities would occur over the duration of operation and be contained within the restricted area of the ISFSI. In addition, the dose at the site boundary would decrease over time because of the decay of the radioactive materials in storage.

As discussed for the other resource areas, overall human health and environmental effects from continued storage during the long-term timeframe would be limited in scope and SMALL for all populations, except for aesthetics, historic and cultural resources, socioeconomic, and traffic conditions. Long-term storage impacts to each of the affected resource areas are discussed elsewhere in this chapter. Due to the passive nature of operations, the temporary nature of any construction associated with the DTS and replacement of the ISFSI and the DTS, and based on the analysis in Section 5.3.1, the NRC concludes that minority and low-income populations are not expected to experience disproportionately high and adverse human health and environmental effects from continued storage during the long-term timeframe.

5.3.3 Indefinite Storage

The human health and environmental effects on minority and low-income populations from continued storage during the indefinite timeframe would be the same as the impacts for long-term storage, as described in Section 5.3.2, except for nonradioactive waste generation and disposal. Indefinite storage impacts associated with nonradioactive waste are summarized later in this chapter. The only difference is that the activities required for maintenance and replacement of the ISFSI and the DTS would be repeated indefinitely. Therefore, the NRC concludes that minority and low-income populations are not expected to experience disproportionately high and adverse human health and environmental effects during the indefinite storage timeframe.

5.4 Air Quality

This section describes air quality impacts caused by the continued storage of spent fuel at an away-from-reactor ISFSI. See Section 3.4.3 for additional information regarding air quality standards.

5.4.1 Short-Term Storage

For the purposes of its analysis of air quality impacts in this GEIS, the NRC will use the information regarding the emissions from construction and operations activities at the PFSF (e.g., construction vehicles, land disturbance, fuel receipt, and routine maintenance and monitoring), because they would be representative of the activities and air emission levels of a similar away-from-reactor ISFSI, regardless of location. In the PFSF EIS (NRC 2001), the NRC examined air quality impacts related to construction and operation of an away-from-reactor ISFSI with a capacity of 40,000 MTU, as well as the construction of a rail spur to transport spent fuel to and from the ISFSI, located in a National Ambient Air Quality Standards attainment area. Fugitive dust would have the greatest influence on air quality during construction. As stated in the PFSF EIS, the magnitude of the impact depends in part on the proximity to receptors. For the construction analysis for the onsite facilities the PFSF EIS concluded that the impacts were SMALL. Atmospheric concentrations of particulate matter with an aerodynamic diameter of 10 microns or less (PM₁₀) were modeled between 1.1 km (0.7 mi) from the center of the proposed facility (i.e., the distance to the nearest publicly owned land) and 3.5 km (2.2 mi) from the center of the proposed facility (i.e., the distance to the nearest residence). Emissions from vehicles were also considered. A maximum of ten equipment operators were expected to be onsite at any one time, and emissions from construction-related equipment were expected to be small. However, due to the large extent of the disturbed area, fugitive dust emitted from excavation and earthwork could lead to local increases in particulate matter concentrations. In its analysis for the PFSF, the NRC made conservative assumptions including the following:

- The entire site area of 30 ha (75 ac) would undergo heavy construction at the same time.

Environmental Impacts of Away-From-Reactor Storage

- Construction was assumed to occur continuously during a 9-hour shift (8 a.m. to 5 p.m. each day).
- Background sources of dust from within a 50-km (32-mi) radius of the site were added to the construction-related dust.
- No mitigation was assumed as a result of natural obstructions (e.g., mountains) that exist between background sources and the PFSF site.

Even when the construction was assumed to be as intensive as that assumed for the PFSF, the modeled concentrations of particulate matter from PFSF construction activities were below the regulatory standards associated with the allowable increases in emission levels for individual projects (i.e., Prevention of Significant Deterioration Class II limits under the Clean Air Act).

For the rail-spur construction analysis, the PFSF EIS concluded that the temporary and localized effects of fugitive dust could produce MODERATE impacts in the immediate vicinity where the rail spur and Interstate 80 were near each other and SMALL impacts elsewhere. Atmospheric concentrations of PM₁₀ were modeled for a total area of 5 ha (12.4 ac) where the rail line ran approximately parallel to Interstate 80 and the rail spur was as close as 50 m (164 ft) to the highway. Dust levels were noticeable, and dust control mitigation measures (e.g., surface wetting) were included to ensure compliance with National Ambient Air Quality Standards.

For an away-from-reactor ISFSI, the NRC assumes that, if necessary, any site-specific permits would include appropriate mitigation to ensure that impacts would not be destabilizing to local air quality. An applicant would also have to comply with the requirements of the General Conformity Rule (Section 176 of the Clean Air Act) if the area in which the ISFSI is to be built has not met the National Ambient Air Quality Standards. Thus, the Clean Air Act permitting process provides a regulatory mechanism to ensure that particulate concentrations created by ISFSI construction would be held below regulatory standards and mitigated as appropriate to protect ambient air quality.

The construction of an away-from-reactor ISFSI of the size assumed by the NRC in the introduction to this chapter of the GEIS would generate emissions similar to those evaluated in the PFSF EIS because similar activities would have to be carried out at the generic facility. Based on the emission levels associated with continued storage, construction impacts would depend on the proximity of the receptor to the emission-generating activities. The NRC expects that noticeable impacts resulting from the proximity between emission sources and receptors would more likely be associated with rail-spur construction rather than ISFSI facility construction because of the distance between the ISFSI construction activities and the site boundary. Therefore, the NRC concludes that for an area that is in attainment for the National Ambient Air Quality Standards, the construction impacts could range from not noticeable to noticeable but not destabilizing.

The NRC also considered how construction-related emissions might affect areas designated by the EPA as “maintenance” or “nonattainment” for criteria pollutants.⁴ Estimated annual emissions of criteria pollutants at the PFSF were much lower than *de minimis* levels described in 40 CFR 93.153, “Applicability.” For example, the applicant for the PFSF estimated that emissions of nitrogen oxides, a precursor to ozone, would have been less than 10 T/yr (PFS 2001). The *de minimis* level of emissions in even an extreme nonattainment area for ozone is 10 T/yr.

Based on the emission levels discussed above, the NRC concludes that the air quality impacts related to construction of an away-from-reactor ISFSI could range from not noticeable to noticeable but not destabilizing in any air quality region. Noticeable but not destabilizing impacts, if they occur, would be due to fugitive dust emissions in the areas immediately adjacent to the rail-spur construction activities.

As stated in the PFSF EIS (NRC 2001), during operations the PFSF would not have been a “major stationary source” of air emissions as defined in 40 CFR 52.21(b). The PFSF analyses considered emissions from sources such as space heaters, emergency generators, and a concrete batch plant, as well as vehicle emissions, and stated that if the emissions from these sources were combined, the total would not be expected to exceed the significance levels for Prevention of Significant Deterioration analysis specified in 40 CFR 51.166(b)(23)(i). The PFSF EIS concluded that the operations impacts on air quality would be SMALL. The NRC determined that the results of this PFSF EIS would be applicable to any away-from-reactor ISFSI with a similar 40,000-MTU capacity because the types of emission-generating activities and associated emission levels would be similar. Therefore, the NRC concludes that the air quality impacts from the operation of the ISFSI would be minor.

Transportation of spent fuel from reactor sites to the away-from-reactor ISFSI could also contribute to air quality impacts. In the PFSF EIS, the NRC stated that the locomotives using the rail line would have emitted pollutants in any one area for a very short period before moving on. The NRC concluded that the associated air quality impacts would be small (NRC 2001). For the analysis of an away-from-reactor ISFSI in this GEIS, the NRC concludes that the basis for the PFSF conclusion would be applicable to any ISFSI because the same amount of fuel would have to be transported over similar distances. Therefore, the air quality impacts associated with the transportation of spent fuel to the site would be minor.

⁴ The EPA designates an area as “nonattainment” generally based upon air quality monitoring data or modeling studies that show the area violates, or contributes to violations of, the national standard. After a nonattainment area’s air quality improves so that it is no longer violating or contributing to violations of the standard, and the State or Tribe adopts an EPA-approved plan to maintain the standard, the EPA can redesignate the area as attainment. These areas are known as “maintenance” areas. See also Section 3.4.3.

Environmental Impacts of Away-From-Reactor Storage

Overall, the NRC concludes that the air quality impacts from the construction and short-term operation of an away-from-reactor ISFSI would be SMALL to MODERATE. MODERATE impacts, if they occur, would be due to fugitive dust emissions in the areas immediately adjacent to the rail-spur construction activities.

5.4.2 Long-Term Storage

Activities associated with aging management of spent fuel in dry casks (e.g., cask repair, bare fuel handling as part of repackaging operations, and replacement of the ISFSI and the DTS) are expected to be of relatively short duration and limited extent. These activities are likely to involve only a portion of the ISFSI and would likely involve, in any year, only a fraction of the air emissions that were associated with initial construction of the ISFSI. Maintenance of the rail spur would also occur during long-term storage. As a result, there may be temporary increases in levels of fugitive dust from construction and refurbishment activities. But the impacts on air quality would be less than those of initial construction because the work would be performed in stages over an extended period of time, as needed.

The NRC assumes that a DTS would have to be constructed and replaced during the long-term storage timeframe. However, as discussed in Section 5.1, the DTS is a relatively small facility and the air quality impacts associated with its construction would be a fraction of the impacts associated with the original construction of the ISFSI. Exhaust from vehicles for commuting workers and material transportation would add to levels of hydrocarbons, carbon monoxide, and nitrogen oxides. However, these emissions would be less than those during the construction period and are not expected to noticeably affect air quality in the region.

Overall, the NRC concludes that the impacts on air quality would be SMALL for all location classifications (i.e., attainment, nonattainment, and maintenance).

5.4.3 Indefinite Storage

This section evaluates the air quality impacts of away-from-reactor storage, assuming a repository does not become available. The same activities described in Section 5.4.2 would occur repeatedly because the spent fuel would remain at the facility indefinitely. Therefore, the NRC concludes that the impacts on air quality associated with continuing spent fuel storage for an indefinite period would be SMALL for all location classifications (i.e., attainment, nonattainment, and maintenance).

5.5 Climate Change

In this section, the NRC evaluates the effect of continued storage at an away-from-reactor ISFSI on climate change. The NRC's evaluation of the effects of climate change on the intensity and frequency of natural phenomena hazards that may cause spent fuel storage accidents is provided in Sections 4.18.

5.5.1 Short-Term Storage

The issue of climate change was not specifically addressed in the PFSF EIS. Therefore, for the purposes of this GEIS, the NRC assumes that the greenhouse gas emission levels released from the construction and operation of a 1,000-MW(e) reference reactor would bound those associated with a 40,000-MTU ISFSI (NRC 2013b). Construction and operation of light water reactors involves, among other things, substantial earthwork and soil dewatering, concrete batch plant operations, making and emplacing many thousands of metric tons of concrete, ironworks, lifting and rigging construction materials and equipment, material transportation, equipment maintenance, demolition, and workforce transportation. Because these activities are of a far greater scale than that for an away-from-reactor ISFSI, the greenhouse gas emission levels from the construction and operation of a 1,000-MW(e) reference reactor bound the emissions from the construction and operation of an away-from-reactor ISFSI.

In its "Interim Staff Guidance on Environmental Issues Associated with New Reactors, Attachment 1: Staff Guidance for Greenhouse Gas and Climate Change Impacts for New Reactor Environmental Impact Statements" (NRC 2013b), the NRC categorized emission levels by project phases. The NRC assumed a 7-year construction period, which would generate a total of 82,000 MT of carbon dioxide (CO₂) equivalent (approximately 12,000 MT/yr). The analysis assumed an average workforce of 1,000 workers, which is roughly 4 times the number of workers assumed to build the ISFSI. Although the new reactor analysis did not include transport of supplies and waste materials, which would also generate greenhouse gases during construction, the number of vehicles transporting workers to a new reactor construction site vastly exceeds the number of vehicles transporting supplies and materials. Therefore, the 4:1 ratio between workers at a new reactor construction site and an ISFSI construction site still provides a very conservative, bounding calculation of 12,000 MT/yr in greenhouse gas emissions, even including the emissions from the transport of supplies and waste materials for the ISFSI. For the PFSF, Phase 1 of the construction, which was to encompass the bulk of construction, was scheduled for 18 months. Using a conservative estimate of 2 years, construction of the ISFSI would lead to greenhouse gas emissions of about 24,000 MT.

For a reactor during the operations period, the NRC estimated a workforce of 550 and total CO₂ emissions (including emissions from support equipment) of 317,000 MT over 40 years. This equates to approximately 8,000 MT/yr (NRC 2013b). Similar to the construction estimate,

Environmental Impacts of Away-From-Reactor Storage

the new reactor analysis did not include transport of supplies and waste materials that would also generate greenhouse gases during operations. However, the workforce assumed for the reactor is about 10 times the workforce that would be needed for the ISFSI and there is more support equipment (e.g., emergency diesel generators) at the reactor as well. Therefore, for the purposes of estimating the impacts for the ISFSI, the 8,000 MT/yr produced by an operating reference reactor is a conservatively high number.

Transportation of spent fuel from the reactor sites to the away-from-reactor ISFSI would also involve emissions of CO₂.⁵ A similar issue was considered in the U.S. Department of Energy (DOE) EIS for Yucca Mountain (DOE 2002) and DOE's 2008 Final Supplemental EIS for Yucca Mountain (DOE 2008). These EISs considered the transportation of 70,000 MTU of spent fuel from reactor sites over a 50-year operational period, as opposed to the 40,000 MTU assumed by the NRC for the away-from-reactor ISFSI over a 20-year operational period. In its 2008 Final Supplemental EIS, DOE determined that the movement of the fuel would add less than 0.0006 percent to overall national CO₂ emissions in 2005. The NRC reviewed the analysis performed by DOE and determined that it was generally consistent with NRC and Council on Environmental Quality regulations and NRC guidance for completeness and adequacy (NRC 2008a). Because the annual amount of spent fuel going to an away-from-reactor ISFSI (2,000 MTU/yr based on shipping 40,000 MTU in 20 years) is a factor of 1.4 greater than the annual amount considered in the Yucca Mountain EIS (1,400 MTU/yr based on shipping 70,000 MTU in 50 years) and emissions are proportionate to the amount of fuel shipped, the emissions from the transportation of spent fuel from reactors to the away-from-reactor ISFSI would be less than double the low proportion (less than 0.0006 percent) of national CO₂ emissions calculated in the Yucca Mountain Final Supplemental EIS. Because this transportation adds only slightly to existing traffic, and because emissions would be dispersed over a wide area between the reactor sites and the ISFSI, the NRC concludes that the greenhouse gas emissions impacts from the transportation of that spent fuel would be minor.

The total emissions associated with constructing (2 years at 12,000 MT/yr) and operating the facility over the short-term timeframe of 60 years (60 years at 8,000 MT/yr) would be 504,000 MT; the average emissions rate would be about 8,200 MT/yr. The annual emission values for the various phases represent a small percentage of the total U.S. annual emission rate of 6.7 billion MT CO₂ equivalent in 2011 (EPA 2013a). To put the annual emissions in context, 8,200 MT CO₂ equivalent would be approximately equal to the annual emissions from 1,640 passenger vehicles (EPA 2013b). During the construction period, when emissions are higher than the average, the 12,000 MT CO₂ equivalent would be approximately equal to the annual CO₂ equivalent emissions from 2,400 passenger vehicles.

⁵ As indicated in the introduction to this chapter, the potential impacts from transportation of spent fuel from an away-from-reactor ISFSI to a repository are not evaluated in this section.

The NRC concludes that the relative contribution of an away-from-reactor ISFSI to greenhouse gas emission levels would be SMALL.

5.5.2 Long-Term Storage

Activities associated with aging management of spent fuel in dry casks (e.g., cask repair, construction of the DTS, bare fuel handling as part of repackaging operations, and ISFSI and DTS replacement) are expected to be of relatively short duration and limited extent. These activities are likely to involve only a portion of the ISFSI, and would likely involve, in any year, only a fraction of the greenhouse gas emissions associated with initial construction of the storage facilities (see Sections 5.1.2 and 5.4.2). Therefore, the NRC concludes that the relative contribution of spent fuel transfer, handling, and aging management activities to greenhouse gas emission levels during the long-term timeframe would be SMALL, for the same reasons stated in Section 5.5.1.

5.5.3 Indefinite Storage

This section describes the environmental impacts on climate change if spent fuel must be stored indefinitely. Ongoing transfer, handling, and aging management activities would continue indefinitely, the ISFSI and DTS would be replaced, and the spent fuel would be repackaged every 100 years. The main difference when compared to the impacts described in Sections 5.5.1 and 5.5.2 is that without a repository these activities would occur on an ongoing basis over a longer period of time. However, the annual emission levels for the various phases would remain the same.

The NRC concludes that the relative contribution of an away-from-reactor ISFSI to annual greenhouse gas emission levels during the indefinite timeframe would be SMALL, the same as the emissions discussed in Section 5.5.2.

5.6 Geology and Soils

This section describes geology and soils impacts caused by the continued storage of spent fuel at an away-from-reactor ISFSI.

5.6.1 Short-Term Storage

Construction impacts associated with away-from-reactor storage include earth clearing and foundation laying for the ISFSI, both of which may contribute to soil erosion. As discussed in the introduction to this chapter, these activities would be similar to those described in the PFSF EIS, regardless of the location of the ISFSI. As described in the PFSF EIS, the environmental impacts on soils would have included the loss of soils as a result of physical alterations to the existing soil profile. These alterations would have led to a reduced availability to support plant

Environmental Impacts of Away-From-Reactor Storage

and animal life and could have led to changes in erosion patterns and characteristics that affect how water infiltrates into the soil (NRC 2001). However, in the PFSF EIS, the NRC concluded that these losses are a small percentage of the similar available soils in the valley. The NRC also noted that soils used in project construction are recoverable upon facility decommissioning, and that no excess soils would be generated that require shipment or disposal offsite. Similarly, economic geologic resources (such as minerals, oil, and gas, if any) that would be unavailable for exploitation during facility construction and operation are widely available elsewhere in the region.

As discussed in Section 5.1, the amount of land committed to the away-from-reactor ISFSI is relatively small compared, for example, to the land available in a typical county. The methods necessary to control soil erosion are well understood and local permits typically require the implementation of erosion controls. Because of the relatively small size of the facility, restrictions on access to geologic resources under the ISFSI site would also be minimal. For these reasons, the NRC concludes that the impacts on soils and geologic resources from the building and short-term operation of an away-from-reactor ISFSI would be SMALL.

5.6.2 Long-Term Storage

The NRC expects that the construction of a DTS (see Chapter 2 for further details) will have minimal impacts on geology and soils due to the small size of the facility (about 0.7 ha [2 ac] for the DTS security zone). The types of impacts on soils would be similar to those anticipated for any power plant facility construction. Due to the relatively small size of the DTS, the impacts would be limited to the immediate area. Also, any laydown areas associated with construction would be reclaimed once the construction phase was complete.

It is assumed that ISFSI pads and supporting facilities (e.g., canister transfer building) would require replacement during the long-term storage timeframe and would occur on land near existing facilities. It is not anticipated that the overall land disturbed would increase because the old facility location would be demolished and the land would likely be reclaimed. Even if the land is not reclaimed, it has no further impact on soils and geologic resources because all of the activities would occur inside the 40-ha (99-ac) restricted area. The operations phase of any ISFSI is not anticipated to have any additional impacts on soils above those associated with construction.

In general, while the geological characteristics of the site and vicinity are essential to the safe design and operation of the ISFSI, continued storage of spent fuel does not have a significant environmental impact on geological resources (such as, damage to unstable slopes, adjacent utilities, or nearby structures).

The construction, operation, and replacement of a DTS would have minimal impacts on soils on the small fraction of the land committed for the facility. There are no anticipated impacts on the

geology of an area as the result of either the construction or operation of a DTS. Therefore, the NRC concludes that the environmental impact on geology and soils due to transfer, handling, and aging management of fuel during the long-term storage timeframe would be SMALL.

5.6.3 Indefinite Storage

In this section, the impacts on geology and soils are evaluated for away-from-reactor storage assuming a repository does not become available. The same operations and maintenance activities described in Section 5.6.2 would occur repeatedly because the spent fuel would remain at the facility indefinitely.

An away-from-reactor storage facility would have no additional impact if a repository is not available; therefore, the NRC concludes that the impacts on geology and soils from indefinite storage would be SMALL.

5.7 Surface-Water Quality and Use

This section describes surface-water quality and use impacts caused by the continued storage of spent fuel at an away-from-reactor ISFSI.

5.7.1 Short-Term Storage

Construction of an away-from-reactor ISFSI would require modification of the surface drainage to accommodate increased locally generated stormwater resulting from land cleared of vegetation and the increased area of impervious cover resulting from paved roads, buildings, and thick concrete pads on which spent fuel casks would be placed (NRC 2001). The types of activities carried out at the ISFSI that could affect surface water would be similar to those activities described for the PFSF based on the assumptions presented in the introduction to this chapter.

For the PFSF site, the NRC noted that BMPs would have been used to address stormwater flows, soil erosion, and siltation throughout the construction period. The NRC determined that, during construction, implementation of BMPs would have resulted in impacts on surface-water quality that would have been SMALL. The NRC also determined that, in the unlikely event that severe flooding occurred during the construction period (when the ground-disturbing activities would have made the soil more mobile), impacts on the surface-water hydrological system would have been SMALL to MODERATE.

The methods necessary to control impacts on surface-water quality during the construction of the ISFSI are well understood and local permits typically require the implementation of these controls. Stormwater control measures, which would be required to comply with National Pollutant Discharge Elimination System (NPDES) permitting, would minimize the flow of

Environmental Impacts of Away-From-Reactor Storage

disturbed soils or other contaminants into surface waterbodies. The licensee could also implement BMPs to minimize erosion and sedimentation. The NRC concludes that under normal circumstances, the impacts on surface-water quality would be minor. Depending on the characteristics of the specific location, unforeseen storm events could cause periods during which surface water could be noticeably affected by runoff, erosion, and sediment loads. However, these events would be of short duration, after which water quality would return to normal.

During construction, the PFSF would have used from about 102 m³/d (19 gpm) to more than 520 m³/d (96 gpm) of water (NRC 2001). The water requirements for an away-from-reactor ISFSI would be similar because of its similar size. These water requirements could be met by a combination of groundwater, surface water, or water delivered to the site (by truck or from a local municipal water system). The amount of water required is relatively small. For example, a large power plant with cooling towers might consume approximately 54,500 m³/d (10,000 gpm) during operations. During the operational period, the away-from-reactor ISFSI would be in a passive state and water use would be much lower than during the construction period. The PFSF would have used about 6.8 m³/d (1.3 gpm) during operations. Activities would be limited to cask emplacement and site maintenance with very little water use. Transportation of the spent fuel to the ISFSI would not have any impacts on surface-water use or quality. For these reasons, the potential impacts on the surface-water flow system, water availability, and water quality during ISFSI operation are generally expected to be minor.

For construction and operation of the away-from-reactor ISFSI, the NRC concludes that the overall impacts on surface-water use and quality would be SMALL. Although there is a possibility of noticeable impacts during unusual storm events during construction, such impacts would be short-lived before the surface waterbody would return to normal conditions. Therefore, even taking into consideration the impact of such unusual storm events, the overall impact would be SMALL.

5.7.2 Long-Term Storage

The construction and operation of a DTS (see Chapter 2 for further details) is anticipated to have minimal impacts on surface-water resources due to the small size of the facility (about 0.7 ha [2 ac] for the DTS security zone) compared to the ISFSI restricted area (40 ha [99 ac]).

The construction and operation of a DTS involves very little consumptive use of water, and this use would be intermittent. Given the relatively smaller size of the DTS compared to a 40,000-MTU away-from-reactor ISFSI, much less water would be required to build the DTS than would be used to construct the ISFSI. Therefore, the consumptive water use for construction and operation of the DTS would be minor.

With regard to storage facility replacement activities, the consumptive water use would be no greater than that identified for initial construction of the facilities, which would have only a minor impact on water availability.

The NRC assumes that the ISFSI and DTS would require replacement during the long-term storage timeframe and that replacement structures would be constructed on land near existing facilities. It is not anticipated that the overall land disturbed would increase because the old facility location would be demolished and the land would likely be reclaimed. This alternating location pattern minimizes the total land disturbed, which would limit the flow of disturbed soils or other contaminants into surface waterbodies. Based on the preceding analysis, expected impacts on surface-water resources would be similar to those in Section 5.7.1, SMALL.

5.7.3 Indefinite Storage

If no repository becomes available, away-from-reactor dry cask storage of spent fuel would continue indefinitely. As a result, the potential impacts on surface-water resources would be similar to those described in Section 5.7.2 because the same operational activities would be happening at the storage site. Every 100 years, surface water would be needed for demolishing and replacing concrete pads and other possibly degraded facilities. This additional consumptive use would be temporary. Therefore, the NRC concludes that the potential impacts on surface-water use and quality if a repository is not available would be SMALL.

5.8 Groundwater Quality and Use

This section describes groundwater-quality and -use impacts caused by the continued storage of spent fuel at an away-from-reactor ISFSI.

5.8.1 Short-Term Storage

Construction of an away-from-reactor ISFSI would require only shallow excavations for the concrete pad foundation and all structures for ISFSI facilities would be at or near the ground surface.

The water-use requirements for the away-from-reactor ISFSI would be similar to those for the PFSF because of its similar size. This water could be obtained from groundwater sources. For the PFSF site, the NRC noted that water use during construction would have varied from about 102 m³/d (19 gpm) to more than 520 m³/d (96 gpm) (NRC 2001), as discussed in Section 5.7.1. For an away-from-reactor ISFSI, these water requirements could be met by a combination of groundwater, surface water, or water delivered to the site (by truck or from a local municipal water system). The amount of water required is relatively small. For example, a large power plant with cooling towers might consume approximately 54,500 m³/d (10,000 gpm) during operations. In the PFSF EIS (NRC 2001), the NRC determined that environmental impacts from

Environmental Impacts of Away-From-Reactor Storage

consumptive use of groundwater during construction of the proposed facility would have been SMALL. Because of the relatively small amount of consumptive water use and the ability to obtain water from multiple sources, the NRC concludes that the impacts of consumptive use of groundwater for an away-from-reactor ISFSI would be minor.

Potential impacts on groundwater quality would be expected to originate through seepage from ground-surface features, such as contaminants in runoff from the concrete pad surfaces and overlying surface waterbodies. The potential impacts on groundwater quality from an away-from-reactor ISFSI would depend on local conditions. The methods to control impacts on groundwater quality are well understood and local permits typically require the implementation of these controls. Under these permits, licensees would be required to implement BMPs to mitigate any potential impacts on groundwater from fuels and other ground-surface contaminants. For this reason, the NRC concludes that the impacts on groundwater quality would be minor. By way of comparison, the impacts on groundwater quality from the PFSF construction were determined by the NRC to be SMALL, given the depth to groundwater (about 38 m [125 ft]) and mitigation afforded by the PFS BMP plan. Groundwater-quality impacts during PFSF operation were also deemed to be SMALL. This finding included consideration of operation of a surface-water detention basin, two planned septic systems with leach fields, and storage of onsite vehicle fuel.

Transportation of the spent fuel to the ISFSI would not have any impacts on groundwater use or quality.

Based on the considerations discussed above, the NRC concludes that the impacts on groundwater use and quality from construction and short-term operation of the away-from-reactor ISFSI would be SMALL.

5.8.2 Long-Term Storage

To accomplish spent fuel repackaging into new canisters, the NRC assumes that a DTS would be required, as described in Chapter 2. The environmental impacts on groundwater from constructing a DTS would be smaller than those considered for construction of the away-from-reactor ISFSI (Section 5.8.1) because of the small area of land affected. Likewise, the impacts of replacing the ISFSI and the DTS over time would be no more than the impacts of the initial construction of the facility because they involve similar activities and would likely occur over a longer period of time. As a result, the NRC concludes that the impacts on groundwater use and quality of long-term storage of spent fuel would be SMALL.

5.8.3 Indefinite Storage

If a repository does not become available, then activities described in Section 5.8.2 would continue indefinitely, including replacement of the ISFSI and DTS every 100 years. The

potential environmental impacts on groundwater would be similar to those discussed in Section 5.8.2. Therefore, the NRC concludes that the potential environmental impacts on groundwater use and quality due to indefinite storage of spent fuel at an away-from-reactor ISFSI would be SMALL.

5.9 Terrestrial Resources

This section describes terrestrial resource impacts caused by the continued storage of spent fuel at an away-from-reactor ISFSI.

5.9.1 Short-Term Storage

Construction of an away-from-reactor ISFSI that would affect terrestrial ecology involve land clearing, grading, and building facilities, including access roads and a rail spur. During construction of an away-from-reactor dry cask storage facility, vegetation would be most affected by the direct removal of trees, plants, shrubs, and grasses and by replacing some of the cleared land with structures and ancillary facilities, including access roads. These removal activities could result, to varying degrees, in reduction of available wildlife habitat and food; modification of existing vegetative communities; and potential establishment or spread of invasive plant species. Parts of the disturbed areas would be replanted with some mixture of native and non-native plant species. Terrestrial wildlife would be most affected by habitat loss or alteration, displacement of wildlife, and incremental habitat fragmentation, all of which can lead to direct and indirect mortalities. However, in general, most wildlife would disperse from the project area when construction activities begin nearby and may recolonize in adjacent, undisturbed areas. In addition, wildlife could be disturbed by noise from construction equipment and vehicle traffic. Collisions with vehicles could be responsible for direct mortality of both large and small animals.

The NRC evaluated site-specific construction impacts on terrestrial ecological resources from an away-from-reactor dry storage facility as part of the PFSF EIS (NRC 2001). Based on the assumptions presented in the introduction to this chapter, land-disturbing activities for an away-from-reactor ISFSI would be of a similar magnitude. For the PFSF, the NRC evaluated the clearing of 94 ha (232 ac) for the main facility and access road, of which 37 ha (92 ac) were to be revegetated after construction and 57 ha (140 ac) were to remain cleared for the life of the project. The PFSF also required the addition of a 51-km (32-mi) rail line that involved the clearing of 314 ha (776 ac), of which 251 ha (621 ac) were to be revegetated after construction and 63 ha (155 ac) were to remain cleared for the life of the project (NRC 2001). The proposed PFSF, located in an arid, shrub-saltbush vegetation community, was expected to store as many as 4,000 canisters in individual storage casks to store a maximum of 40,000 MTU of spent fuel. The PFSF had drainages in the area that were ephemeral. However, no wetlands were on or near the proposed PFSF, and there would have been no direct impacts on wetlands from

Environmental Impacts of Away-From-Reactor Storage

construction (NRC 2001). It is likely that an away-from-reactor storage facility would also be located in an area away from sensitive perennial and wetland habitats to satisfy laws such as the Endangered Species Act (ESA) and the Clean Water Act (for wetlands). However, in some locations sensitive terrestrial features may be unavoidably affected.

The NRC concluded that the direct impact on vegetation from clearing vegetation and disrupting the ground surface from the proposed PFSF would have been SMALL because no unique habitats occur in the proposed project area (NRC 2001). The NRC further concluded that vegetation removal impacts that reduce habitat, alter prey-predator relationships, and force animals to leave the area would have been SMALL. The NRC also concluded that indirect impacts from the proposed PFSF, including surface-water runoff from impermeable surfaces, restricting large animal movement, construction noise, introduction of non-native plant species, groundwater withdrawal effects on vegetation, and ground and vegetation disturbances from trucks and associated fugitive dust, would also have been SMALL (NRC 2001).

For an away-from-reactor ISFSI at a different location, the impacts on terrestrial resources could be different from those at the PFSF. However, certain factors tend to limit the impacts, including the following:

- The land area permanently disturbed is relatively small.
- Any impacts on wetlands must be addressed under the Clean Water Act and, if wetlands are present, the applicant must demonstrate that the proposed action is the least environmentally damaging practicable alternative.

Even considering these factors, it is possible that the construction of the project could have some noticeable, but not destabilizing, impacts on terrestrial resources, depending on what resources are affected, as demonstrated by other environmental reviews the NRC has performed (e.g., reviews for new reactors). Given the passive nature of ISFSI operations, impacts on terrestrial resources from such operations (e.g., reduced available habitat, reduced mobility of terrestrial animals, and increased noise, light, and traffic) would be much less than the impacts of construction and would be minimal. Transportation of the spent fuel to the ISFSI would have little or no impacts on terrestrial resources. Therefore, the NRC concludes that, depending on the characteristics of the particular site, the impacts on terrestrial resources could range from SMALL to MODERATE, based primarily on the potential impacts of construction activities.

5.9.2 Long-Term Storage

As described previously in Section 5.1.2, the NRC assumes that a DTS would be constructed as part of an away-from-reactor ISFSI. This facility would be used to facilitate repackaging of spent fuel or replacement of damaged canisters or casks identified during visual inspections or aging management activities. Construction of a DTS is anticipated to last about 2 years (see

Section 5.1.2), and only a small portion of the land committed for an away-from-reactor ISFSI is required to construct and operate a DTS.

The NRC assumes that because only a small portion of the land committed for an away-from-reactor ISFSI is required to construct and operate a DTS, the impacts from construction and operation of a DTS on terrestrial resources would be significantly less than those from construction and operation of an away-from-reactor ISFSI. The DTS could be sited on previously disturbed ground, probably away from sensitive terrestrial features, due to the relatively small land area affected for a DTS security zone (about 2 ac).

Operational impacts would include reduced available habitat and mobility of terrestrial animals and increased noise, light, and traffic. Maintenance activities would include inspections and testing of the spent fuel and cask transfer and handling equipment and process and effluent radiation monitoring, which do not increase erosion, fugitive dust, traffic, noise, light, or release of contaminants or require any change to land use. As the ISFSI and the DTS are replaced during the long-term storage timeframe, it is anticipated that there would be no new or additional activities from those described above. The potential impacts would be less than the impacts the NRC evaluated in Section 5.9.1 because replacement activities would occur within the operational area near existing facilities. For these reasons, the NRC concludes that the impact on terrestrial resources due to transfer, handling, and aging management of spent fuel at an away-from-reactor ISFSI during the long-term storage timeframe would be SMALL.

5.9.3 Indefinite Storage

Impacts on terrestrial resources from continued operation of an away-from-reactor ISFSI if a repository is not available would be similar to those described in Section 5.9.2. The same operations and maintenance activities described in Section 5.9.2 would occur repeatedly because the spent fuel would remain at the facility indefinitely.

Based on the NRC's evaluation of the impacts from operations of an away-from-reactor ISFSI in Section 5.9.2, the NRC concludes that the environmental impacts on terrestrial resources from dry cask storage of spent fuel at an away-from-reactor ISFSI indefinitely would be SMALL.

5.10 Aquatic Ecology

This section describes aquatic ecology impacts caused by the continued storage of spent fuel at an away-from-reactor ISFSI.

5.10.1 Short-Term Storage

Construction and operation of an away-from-reactor ISFSI would require limited water supplies (see Sections 5.7 and 5.8). Liquid effluents, if any, would be limited to stormwater and treated

Environmental Impacts of Away-From-Reactor Storage

wastewater. The dry cask storage facility could likely be sited away from sensitive aquatic features to comply with the ESA and other environmental laws. Ground-disturbing activities could increase runoff and surface erosion into aquatic habitats. In most cases, aquatic disturbances would result in relatively short-term impacts and the aquatic environs would recover naturally. In addition, stormwater control measures, which would be required to comply with NPDES permitting, would minimize the flow of disturbed soils or other contaminants into aquatic features. The plant operator could also implement BMPs to minimize erosion and sedimentation.

For the PFSF, given the minimal impacts on aquatic biota and minimal aquatic features near the site, the NRC concluded that construction and operational activities at the PFSF would have had negligible direct and indirect impacts on aquatic biota (NRC 2001). This conclusion resulted from the facility's limited water use and the passive nature of facility operations. For an away-from-reactor ISFSI at a different location, the impacts on aquatic resources could be different from those at the PFSF. However, certain factors would tend to limit the impacts, including the following:

- The land area permanently disturbed is relatively small.
- Water use for the construction and operation of the site is limited.
- Any impacts from discharges to waterbodies must be addressed under the Clean Water Act and an associated NPDES permit must be obtained for such discharges, including stormwater runoff.

Considering all of these factors, the NRC concludes that the impacts on aquatic resources would be SMALL.

5.10.2 Long-Term Storage

Building a DTS and activities related to the transfer and handling of spent fuel and aging management at away-from-reactor ISFSIs could result in ground-disturbing activities that would have similar impacts to those analyzed in Section 5.10.1. For example, ground-disturbing activities could increase runoff and surface erosion into aquatic habitats. The ISFSI and the DTS would be replaced during the long-term storage timeframe. The NRC anticipates that aquatic impacts from these activities would be within the bounds of those described in Section 5.10.1. The potential impacts may be less than the impacts the NRC evaluated in Section 5.10.1 because replacement activities would occur within the facility's operational area near existing facilities over an extended period of time. In most cases, aquatic disturbances, if any, would result in relatively short-term impacts and the aquatic environs would recover naturally. Required mitigation related to NPDES or other permits would also reduce impacts. Therefore, the NRC concludes that impacts on aquatic resources from long-term storage at away-from-reactor ISFSIs would be SMALL.

5.10.3 Indefinite Storage

Impacts on aquatic resources from maintenance and operation of an away-from-reactor ISFSI if no repository becomes available would be similar to those described in Section 5.10.2. The same operations and maintenance activities described in Section 5.10.2 would occur repeatedly because the spent fuel would remain at the facility indefinitely. As described in Section 5.10.2, these activities could result in minimal, short-term impacts on aquatic resources. Therefore, the NRC concludes that impacts on aquatic resources for indefinite storage of spent fuel at an away-from-reactor ISFSI would be SMALL.

5.11 Special Status Species and Habitats

This section describes special status species and habitat impacts caused by the continued storage of spent fuel at an away-from-reactor ISFSI.

5.11.1 Short-Term Storage

Impacts from the construction and operation of dry cask storage facilities on special status species and habitats would be similar to those described above for terrestrial and aquatic resources, which would range from minimal to noticeable; any noticeable impacts would result from the construction of the ISFSI. The NRC assumes that the dry cask storage facility could be sited to avoid adversely affecting special status species and habitat because of the facility's relatively small construction footprint and limited use of water. However, if an away-from-reactor ISFSI was located in area that could affect Federally listed species or designated critical habitat, consultation under Section 7 of the ESA would be required.

Prior to initial licensing of the facility, the NRC would coordinate with the U.S. Fish and Wildlife Service (FWS) or the National Marine Fisheries Service (NMFS) to determine the presence of any Federally listed species or designated critical habitat at or near the site. If Federally listed species or designated critical habitat could be affected by the facility, the NRC would be required to initiate ESA Section 7 consultation. This consultation may be either formal or informal, depending on the specific adverse effect. In the case of an adverse effect for which the NRC would issue a biological assessment that initiates formal consultation, the FWS or NMFS would issue a biological opinion in accordance with the provisions of formal consultation at 50 CFR 402.14. The FWS or NMFS could issue, with a biological opinion, an incidental take statement that exempts a certain incidental take of Federally listed species and reasonable and prudent measures necessary or appropriate to minimize impacts to Federally listed species and designated critical habitats. Following the conclusion of an initial consultation, 50 CFR 402.16 directs Federal agencies to reinitiate consultation where discretionary Federal involvement or control over the action has been retained or is authorized by law and where (1) the amount or extent of taking specified in the incidental take statement is exceeded, (2) new information reveals effects to Federally listed species or designated critical habitats that were not previously

Environmental Impacts of Away-From-Reactor Storage

considered, (3) the action is modified in a manner that causes effects not previously considered, or (4) new species are listed or new critical habitat is designated that may be affected by the action.

Thus, the ESA consultation process would identify potential impacts on Federally listed species and potentially require monitoring and mitigation to minimize impacts on Federally listed species. In addition, the official lists of Federally listed species and designated critical habitats are updated by the FWS or NMFS. Species may be added to the list or delisted. If new species are listed under the ESA, the NRC would assess any potential impacts on those species at the away-from-reactor ISFSI at the time of listing. Therefore, if a new species is listed after the ISFSI receives its license, and if the criteria in 50 CFR Part 402 are met for initiation or reinitiation of Section 7 consultation, the NRC would initiate or reinitiate ESA Section 7 consultation with the FWS or NMFS if the newly listed species may be affected by the ISFSI. Additional details and guidance regarding the consultation process are provided in 50 CFR Part 402 and in the *Endangered Species Consultation Handbook* (FWS/NMFS 1998), respectively.

In addition, NRC and licensee coordination with other Federal and State natural resource agencies would further encourage licensees to take appropriate steps to avoid or mitigate impacts on special status species, habitats of conservation concern, and other protected species and habitats, such as those protected under the Fish and Wildlife Coordination Act, Coastal Zone Management Act, Marine Mammal Protection Act, the Migratory Bird Treaty Act, and the Bald and Golden Eagle Protection Act, as applicable. NRC and licensee coordination with other Federal and State natural resource agencies would likely result in avoidance or mitigation measures that would minimize impacts on protected species and habitats. Impacts on essential fish habitat (EFH) from short-term storage are not expected because away-from-reactor ISFSIs are built on land and ground-disturbing impacts would have minimal impacts on aquatic habitats, as described in Section 5.10.1.

The impacts on Federally listed species and designated critical habitat would be determined as part of ESA Section 7 consultation. In complying with the ESA, the NRC would evaluate the impacts of ISFSI construction, operations, and decommissioning in a site-specific review before the ISFSI is initially constructed and afterwards if an activity meets the criteria in 50 CFR Part 402 for initiation or reinitiation of Section 7 consultation. The FWS ESA guidance provides four categories by which the NRC would characterize the effects of ISFSI construction, operation, and decommissioning: (1) no effect, (2) may affect but is not likely to adversely affect, (3) may affect and is likely to adversely affect, or (4) is likely to jeopardize the continued existence of the listed species or destroy or adversely modify the designated critical habitat of Federally listed species populations. In the unlikely situation that construction or operation of an ISFSI could adversely affect EFH, and if the criteria are met in 50 CFR Part 600 for initiation of consultation

under the Magnuson–Stevens Fishery Conservation and Management Act, the NRC would be required to initiate EFH consultation with NMFS.

Given flexibility in site selection and the limited size of an ISFSI, the ISFSI can likely be sited to minimize adverse effects on special status species and habitats. Accordingly, the NRC concludes that the construction and operation of the ISFSI could have minimal to noticeable impacts on State-listed species, marine mammals, migratory birds, and bald and golden eagles.

5.11.2 Long-Term Storage

As described above, the NRC would evaluate the impacts on Federally listed species and designated critical habitat from construction and operation of the ISFSI in a site-specific review as required under the ESA. This evaluation would include the potential impacts from transfer, handling, and aging management activities, including ISFSI and DTS replacement. If transferring, handling, or aging management resulted in a take of a Federally listed species, and if the criteria in 50 CFR Part 402 are met for initiation or reinitiation of ESA Section 7 consultation, the NRC would initiate or reinitiate consultation with the FWS or NMFS.

During long-term storage, the NRC assumes that the licensee would have to build a DTS. The NRC authorization to construct and operate a DTS would constitute a Federal action under NEPA and would be addressed pursuant to 10 CFR Part 51. Prior to authorization, the NRC would coordinate with FWS or NMFS to determine the presence of any Federally listed species or designated critical habitat at or near the site. If Federally listed species or designated critical habitat occur near the site and could be affected by the facility, the NRC would be required to initiate ESA Section 7 consultation, as described in Section 5.11.1. Because the ISFSI and the DTS would be replaced during the long-term storage timeframe, the NRC anticipates that the impacts on special status species and habitats would be within the bounds of those described above. The potential impacts would most likely be less than the impacts the NRC evaluated in Section 5.11.1 because replacement activities would occur within the operational area near existing facilities over an extended period of time.

In addition, NRC and licensee coordination with other Federal and State natural resource agencies would further encourage ISFSI licensees to take appropriate steps to avoid or mitigate impacts to State-listed species, habitats of concern, and other protected species and habitats. NRC and licensee coordination with other Federal and State natural resource agencies would likely result in avoidance or mitigation measures that would minimize impacts on protected species and habitats, such as those protected under the Fish and Wildlife Coordination Act, Coastal Zone Management Act, Marine Mammal Protection Act, the Migratory Bird Treaty Act, and the Bald and Golden Eagle Protection Act, as applicable.

As described above, in complying with the ESA, the NRC would assess the impacts to Federally listed species and designated critical habitat from an away-from-reactor ISFSI and DTS in a

Environmental Impacts of Away-From-Reactor Storage

site-specific review before the facility is initially constructed and afterwards if an activity meets the criteria in 50 CFR Part 402 for initiation or reinitiation of Section 7 consultation. The NRC would characterize the effects of construction and operations in terms of its ESA findings of (1) no effect, (2) may affect but is not likely to adversely affect, (3) may affect and is likely to adversely affect, or (4) likely to jeopardize the listed species, or adversely modify the designated critical habitat of Federally listed species populations. In the unlikely situation that activities during the long-term storage period could adversely affect EFH, and if the criteria are met in 50 CFR Part 600 for initiation of consultation under the Magnuson–Stevens Fishery Conservation and Management Act, the NRC would be required to initiate EFH consultation with NMFS.

Given flexibility in site selection and the limited size of an ISFSI and DTS, these facilities can likely be sited to minimize adverse effects on special status species and habitats. Accordingly, the NRC concludes that operating and replacing components of the ISFSI and DTS could have minimal impacts on State-listed species, marine mammals, migratory birds, and bald and golden eagles.

5.11.3 Indefinite Storage

Impacts on special status species and habitats from continued operation of an away-from-reactor ISFSIs if a repository never becomes available would be similar to those described in Section 5.11.2. The same operations and maintenance activities described in Section 5.11.2 would occur repeatedly because the spent fuel would remain at the facility indefinitely.

As described above, in complying with the ESA, the NRC would evaluate the impacts from an away-from-reactor ISFSI and DTS in a site-specific review before the facility is initially constructed and afterwards if an activity meets the criteria in 50 CFR Part 402 for initiation or reinitiation of Section 7 consultation. The NRC would report the effects of construction and operations in terms of its ESA findings of (1) no effect, (2) may affect but is not likely to adversely affect, (3) may affect and is likely to adversely affect, or (4) likely to jeopardize the listed species, or adversely modify the designated critical habitat of Federally listed species populations. In the unlikely situation that activities during indefinite storage period could adversely affect EFH, and if the criteria are met in 50 CFR Part 600 for initiation of consultation under the Magnuson–Stevens Fishery Conservation and Management Act, the NRC would be required to initiate EFH consultation with NMFS.

Given flexibility in site selection and the limited size of an ISFSI and DTS, the ISFSI and DTS can likely be sited to minimize adverse effects on special status species and habitats. Accordingly, the NRC concludes that operating and replacing components of the ISFSI and DTS could have minimal impacts on State-listed species, marine mammals, migratory birds, and bald and golden eagles.

5.12 Historic and Cultural Resources

This section describes historic and cultural resource impacts caused by the continued storage of spent fuel at an away-from-reactor ISFSI.

The NRC is considering impacts on historic and cultural resources in this GEIS through implementation of its NEPA requirements in 10 CFR Part 51. This rulemaking is not a licensing action; it does not authorize the construction or operation of an away-from-reactor ISFSI, and it does not authorize storage of spent fuel. Because this GEIS does not identify specific sites for NRC licensing actions, an NHPA Section 106 review has not been performed. However, the NRC complies with NHPA Section 106 and the implementing provisions in 36 CFR Part 800 in site-specific licensing actions. As discussed in Section 3.11, identification of historic properties, adverse effects, and potential resolution of adverse effects would be conducted through consultation and application of the National Register of Historic Places criteria in 36 CFR 60.4. This information would also be evaluated to determine the significance of potential impacts on historic and cultural resources in the NRC's environmental review documents.

For site-specific licensing actions (new reactor licensing, reactor license renewal, and site-specific at-reactor and away-from-reactor ISFSIs), the NRC complies with Section 106 requirements to consider the effects of its undertaking on historic properties. If any historic properties are present, their significance would be determined through application of the National Register of Historic Places criteria. If adverse effects to historic properties are identified, appropriate mitigation can be developed through consultation with the State Historic Preservation Officer, or appropriate Tribal Historic Preservation Officer, tribal representatives, and other interested parties. A site-specific license could be issued at the conclusion of the NRC's safety review and environmental review and compliance with NHPA Section 106 requirements.

As discussed in more detail below, the NRC recognizes that there is uncertainty associated with the degree of prior disturbance and the resources, if any, are present in areas where future ground-disturbing activities could occur. The NRC cannot eliminate the possibility that historic and cultural resources would be affected by construction activities because the initial ISFSI could be located within a less-disturbed area with historic and cultural resources in close proximity. Further, resources may be present after initial construction of the away-from-reactor ISFSI that would not have been considered significant at the time the initial or replacement facilities were constructed, but could become significant in the future.

5.12.1 Short-Term Storage

NRC authorization to construct and operate an away-from-reactor ISFSI would constitute a Federal action under NEPA and would be an undertaking under the NHPA. In accordance with

Environmental Impacts of Away-From-Reactor Storage

36 CFR Part 800, the NRC would conduct an NHPA Section 106 review to determine whether historic properties are present in the area of potential effect, and if so, whether construction and operation of the ISFSI would result in any adverse effects on such properties. Prior to submitting an application to construct and operate the ISFSI, the ISFSI applicant would conduct a survey of any areas of proposed development to identify and record historic and cultural resources. Impacts on historic and cultural resources would vary depending on the location of the ISFSI and what resources are present. Resolution of adverse effects to historic properties, if any, should be concluded prior to the closure of the Section 106 process. After construction is completed, disturbed areas not occupied by ISFSI structures and supporting infrastructure (e.g., access roads, parking areas, and laydown areas) would be reclaimed and revegetated.

The environmental impacts on historic and cultural resources from the construction and operation of an away-from-reactor storage facility are informed by the evaluation as described in the PFSF EIS (NRC 2001). The proposed PFSF would have been located on the Reservation of the Skull Valley Band of Goshute Indians, which encompasses 7,200 ha (18,000 ac) in Tooele County, Utah. Storage pads for the canisters and some support facilities would have been located on a 99-ac (40-ha) restricted access area within the PFSF site (NRC 2001). Additional land would have been disturbed for the access road and the new rail line. The NRC assumes that the amount of land disturbance for an away-from-reactor ISFSI would be similar to the land disturbance for the PFSF, as discussed in the introduction to this chapter and Section 5.1.

Extensive work was performed at the PFSF to identify historic and cultural resources on or near the facilities and to evaluate the potential impacts of the project on those resources (NRC 2001). As a result, the NRC concluded that the construction of the rail line would have adversely affected portions of eight historic properties evaluated as eligible for inclusion in the National Register of Historic Places. The NRC included in the PFS license a condition that required the implementation of seven specific requirements for the treatment of historic properties. Operation of the proposed PFSF was not expected to impact historic and cultural resources because no additional ground disturbance would occur (NRC 2001).

For an away-from-reactor ISFSI, the impacts on historic and cultural resources would be different from those at the PFSF, given the difference in sites. However, several factors could avoid, minimize, or mitigate impacts. These include the following:

- Any impacts on historic and cultural resources would be addressed during a site-specific NEPA review. Any adverse effects to historic properties must be addressed under the NHPA in consultation with any affected State or Tribal Historic Preservation Officers, and other interested parties.
- The land area disturbed is relatively small and any one of a number of alternative sites can be selected.

- In most, but not all instances, placement of facilities on a proposed site could be adjusted to minimize or avoid impacts on historic and cultural resources in the area, but the NRC recognizes that this is not always possible. Because an away-from-reactor ISFSI does not depend on a significant water supply and has limited electrical power needs, an applicant may have more flexibility in how it chooses to place facilities on a site and therefore have a greater chance of avoiding historic and cultural resources in the area.
- Potential adverse effects to historic properties and impacts to other historic and cultural resources could be minimized through development of agreements, license conditions, and implementation of the licensees' historic and cultural resource management plans and procedures to protect known historic and cultural resources and address inadvertent discoveries during construction.

However, it may not be possible to avoid adverse effects on historic properties under NHPA or impacts on historic and cultural resources under NEPA. The magnitude of adverse effects on historic properties and impacts on historic and cultural resources largely depends on where facilities are sited, what resources are present, the extent of proposed land disturbance, whether the area has been previously surveyed to identify historic and cultural resources, and if the licensee has management plans and procedures that are protective of historic and cultural resources. Even a small amount of ground disturbance (e.g., clearing and grading) could affect a small but significant resource. In most instances, placement of storage facilities on the site can be adjusted to minimize or avoid impacts on any historic and cultural resources in the area. However, the NRC recognizes that this is not always possible. The NRC's site-specific environmental review and compliance with the NHPA process could identify historic properties, identify adverse effects, and potentially resolve adverse effects on historic properties and impacts on other historic and cultural resources. Under the NHPA, mitigation does not eliminate a finding of adverse effect on historic properties. Therefore, the NRC concludes that the potential impacts on historic and cultural resources could range from SMALL to LARGE, depending on site-specific factors.

Impacts from continued operations and routine maintenance during short-term timeframe would be small because no ground-disturbing activities are expected. Therefore, impacts associated with continued operations and maintenance of the ISFSI on historic and cultural resources during the short-term timeframe would be SMALL.

5.12.2 Long-Term Storage

The NRC assumes that systems, structures, and components of an away-from-reactor ISFSI would be replaced during the long-term storage timeframe. In addition to routine maintenance, the NRC also assumes that a DTS is constructed, operated, and replaced as part of an away-from-reactor ISFSI during the long-term storage timeframe. As discussed in Section 5.1.2 of this GEIS, a DTS would be used to retrieve and repackage spent fuel for aging management

Environmental Impacts of Away-From-Reactor Storage

activities or to replace damaged canisters or casks identified during visual inspections. Construction and operation of a DTS at an away-from-reactor ISFSI is described in Section 2.1.4 of this GEIS.

Impacts from continued operations and routine maintenance during long-term storage would be similar to those described for the short-term storage timeframe. The impacts would be small because there would be no ground-disturbing activities as a result of the continued operations and routine maintenance at the ISFSI.

NRC authorization to construct and operate a DTS and replace the ISFSI and DTS would constitute Federal actions under NEPA and would be undertakings under the NHPA and would require a site-specific environmental review and compliance with NHPA requirements before making a decision on the licensing action. In accordance with 36 CFR Part 800, a Section 106 review would be conducted for each undertaking to determine whether historic properties are present in the area of potential effect, and if so, whether these actions would result in any adverse effects upon these properties. Impacts on historic and cultural resources can vary depending on the location of the original DTS and the replacement ISFSI and DTS and what resources are present. For site-specific licensing actions (new reactor licensing, reactor license renewal, site-specific at-reactor and away-from-reactor ISFSIs, and DTS), applicants are required to provide historic and cultural resource information in their environmental reports. To prepare these assessments, applicants conduct cultural resource surveys. This information assists NRC in its review of the potential impacts on historic and cultural resources. Section 106 of the NHPA requires the NRC to conduct a site-specific assessment to determine whether historic properties are present in the area of potential effect, and if so, whether construction and operation of a DTS would result in any adverse effect upon these properties. Resolution of adverse effects, if any, should be concluded prior to the closure of the Section 106 process.

The NRC assumes that the replacement ISFSI and initial and replacement DTS will be constructed on land near the existing facilities. Ground-disturbing activities occurred during initial ISFSI construction, and much of the land within and immediately surrounding the ISFSI would be disturbed. If the replacement ISFSI and initial and replacement DTS are sited within previously disturbed areas, then impacts would likely be small because initial construction of the ISFSI could have reduced the potential for historic and cultural resources to be present. However, if these facilities were sited in less-developed or disturbed portions of the ISFSI site, then there could be impacts to historic and cultural resources.

Given the land area available around the ISFSI restricted area, the licensee should be able to locate the replacement facilities away from historic and cultural resources. However, the NRC recognizes that it may not be possible for a licensee to avoid adverse effects to historic properties under NHPA or impacts on historic and cultural resources under NEPA. The NRC believes that it is reasonable to assume that the replacement ISFSI and the initial and replacement DTS would be constructed near the existing ISFSI because the licensee would

already have characterized and selected the initial ISFSI site to meet NRC siting, safety, and security requirements. The NRC believes that it is reasonable to assume that licensees would generally avoid siting and operating an ISFSI away from the existing licensed area or outside previously characterized areas. The magnitude of adverse effects on historic properties and impacts to historic and cultural resources during the long-term timeframe largely depends on where the facilities are sited, what resources are present, the extent of proposed land disturbance, whether the area has been previously surveyed to identify historic and cultural resources, and whether the licensee has management plans and procedures that are protective of historic and cultural resources. Even a small amount of ground disturbance (e.g., clearing and grading) could affect a small but significant resource. In most, but not all, instances, placement of storage facilities on the site can be adjusted to minimize or avoid impacts on any historic and cultural resources in the area. Before these ground-disturbing activities occur, the site-specific environmental review and compliance with the NHPA process would identify historic properties and historic and cultural resources that could be impacted. Under the NHPA, mitigation does not eliminate a finding of adverse effect on historic properties; but impacts would be assessed at the time of the future proposed licensing action.

Based on the considerations above, the potential impacts on historic and cultural resources during the long-term storage timeframe would range from SMALL to LARGE. This range takes into consideration routine maintenance and monitoring (i.e., no ground-disturbing activities), the absence or avoidance of historic and cultural resources, and potential ground-disturbing activities that could affect historic and cultural resources. The analysis also considers uncertainties inherent in analyzing this resource area over long timeframes. These uncertainties include any future discovery of previously unknown historic and cultural resources; resources that gain significance within the vicinity and the viewshed (e.g., nomination of a historic district) due to improvements in knowledge, technology, and excavation techniques and changes associated with predicting resources that future generations will consider significant. Potential adverse effects on historic properties or impacts on historic and cultural resources could be minimized through development of agreements, license conditions, and implementation of the licensees' historic and cultural resource management plans and procedures to protect known historic and cultural resources and address inadvertent discoveries during construction of the replacement ISFSI and initial and replacement DTS. If construction of a DTS and replacement of the ISFSI and DTS occurs in an area with no historic or cultural resource present or construction occurs in previously a disturbed area that allows avoidance of historic and cultural resources then impacts would be SMALL. By contrast, a MODERATE or LARGE impact could result if historic and cultural resources are present at a site and, because they cannot be avoided, are impacted by ground-disturbing activities during the long-term timeframe. Accordingly, the NRC has concluded that the impacts on historic and cultural resources for the long-term timeframe would be SMALL to LARGE.

5.12.3 Indefinite Storage

The environmental impacts of indefinite spent fuel storage would be similar to those described in Section 5.12.2. The same operations and maintenance activities described in Section 5.12.2 would occur repeatedly because the spent fuel would remain at the facility indefinitely. During this timeframe, maintenance and monitoring would continue and the at-reactor ISFSI and DTS would be replaced every 100 years. The site-specific environmental review and compliance with the NHPA process would identify historic properties, adverse effects, and potentially resolve adverse effects on historic properties and impacts on other historic and cultural resources. As discussed in Section 5.12.2, the NRC assumes that the replacement of the ISFSI and DTS would be constructed on land near the existing facilities. As stated in Section 1.8, the NRC assumes that the land where the original facilities were constructed will be available for replacement facility construction; however, the NRC cannot eliminate the possibility that historic and cultural resources would be affected by construction activities during the indefinite timeframe because the NRC recognizes that there is uncertainty associated with the degree of prior disturbances and what resources, if any, are present in areas where future ground-disturbing activities (e.g., initial and replacement DTS and replacement ISFSI) could occur. Further, significant resources may be present that were not considered significant at the time the initial or replacement facilities were constructed. Impacts regarding the replacement of the ISFSI and DTS would be similar to those described for the long-term storage timeframe.

Based upon the considerations above, the potential impacts to historic and cultural resources during the indefinite storage timeframe would range from SMALL to LARGE. This range takes into consideration routine maintenance and monitoring (i.e., no ground-disturbing activities), the absence or avoidance of historic and cultural resources, and potential ground-disturbing activities that could impact historic and cultural resources. The analysis also considers uncertainties inherent in analyzing this resource area over long timeframes. These uncertainties include any future discovery of previously unknown historic and cultural resources; resources that gain significance within the vicinity and the viewshed (e.g., nomination of a historic district) due to improvements in knowledge, technology, and excavation techniques and changes associated with predicting resources that future generations will consider significant. Potential adverse effects on historic properties or impacts on historic and cultural resources could be minimized through development of agreements, license conditions, and implementation of the licensees' historic and cultural resource management plans and procedures to protect known historic and cultural resources and address inadvertent discoveries during construction of the replacement ISFSI and replacement DTS. If construction of a DTS and replacement of the ISFSI and DTS occurs in an area with no historic or cultural resource present or construction occurs in previously a disturbed area that allows avoidance of historic and cultural resources then impacts would be SMALL. By contrast, a MODERATE or LARGE impact could result if historic and cultural resources are present at a site and, because they cannot be avoided, are impacted by ground-disturbing activities during the indefinite timeframe.

Accordingly, the NRC has concluded that the impacts on historic and cultural resources for the indefinite timeframe would be SMALL to LARGE.

5.13 Noise

This section describes noise impacts caused by the continued storage of spent fuel at an away-from-reactor ISFSI.

5.13.1 Short-Term Storage

The assessment of the environmental impacts of noise from the construction and operation of an away-from-reactor ISFSI is informed by those described in the PFSF EIS (NRC 2001). Background noise levels within the vicinity of the PFSF (Skull Valley) are low, as would be expected for any remote location. The EPA (1974) has provided guideline sound levels below which the general public would be protected from activity interference and annoyance; 55 dBA applies to outdoor locations “in which quiet is a basis for use” and 45 dBA applies to indoor residential areas (NRC 2001).

Construction of the ISFSI facility occurs during a small portion of the short-term timeframe. The schedule for the proposed PFSF called for the first stage of construction, which included the major buildings and one-fourth of the total number of proposed storage pads, to last 18 months (NRC 2001). Noise impacts would result from construction equipment used to grade and level the site, excavate the facility foundation, handle building materials, build the ISFSI facilities (e.g., buildings, storage pads, access road, new rail siding, and new rail spur), and from additional construction traffic. Construction equipment associated with these activities can generate noise levels up to 95 dBA (NRC 2001). This noise level applies at a reference distance of 15 m (50 ft) from the source. Noise levels decrease by about 6 dBA for each doubling of distance from the source. At distances greater than about 1.9 km (1.2 mi), expected maximum noise levels would be less than the 55 dBA recommended by the EPA for protection against outdoor activity interference and annoyance (NRC 2001). For the PFSF, construction-related noise levels were expected to be less than 48 dBA in the ambient air at the nearest residences (at a distance of roughly 3 km [2 mi]). Therefore, noise from construction activity was not expected to be annoying for residents located in the nearest houses (NRC 2001). However, for an away-from-reactor ISFSI at a different location, the nearest resident could be closer and noise levels during construction could exceed the EPA recommendation. Whether associated noise impacts could or would be mitigated could only be determined during a site-specific review.

Construction would also result in increased vehicle traffic (e.g., commuting workforce, construction vehicles, and material transport) and an associated increase in noise. For the PFSF this would have increased noise levels by 5 dBA (NRC 2001). The impacts of the

Environmental Impacts of Away-From-Reactor Storage

increase in noise around the ISFSI will depend considerably on the nature of the area through which the traffic is passing. Because the NRC expects that the ISFSI will be built in a remote location with little pre-existing traffic, the noise from the additional traffic is likely to be noticeable and could exceed the EPA recommendation. However, the duration of the most intense portion of the construction period would be limited (roughly 18 months for the PFSF).

Operation of the ISFSI would involve transporting, receiving, handling, and storing spent fuel, as well as routine maintenance and monitoring of the ISFSI. Cask transportation, receiving, and handling would be the primary noise sources during operations; the loudest onsite noise source would most likely be the onsite locomotive diesel switch engine. The train whistle from this locomotive could be audible at nearby residences. Momentary noise from routine operation could exceed 100 dBA. However, this locomotive would only operate a few hours per week (NRC 2001). Because the locomotive would be expected to operate only a few hours per week, indoor and outdoor noise impacts are expected to be minimal.

Noise impacts could also be associated with the transportation of spent fuel to the site. In the PFSF EIS (NRC 2001), the NRC estimated that an average of 150 loaded transportation packages would be received at the facility each year, carried by 1 or 2 trains per week, and a similar frequency is assumed for the ISFSI. While the train's whistle would be loud, trains would be passing only infrequently. Therefore, the NRC concludes that the noise impacts resulting from transportation of spent fuel to the ISFSI would be minor.

In conclusion, the NRC determined that the construction and operation noise impacts for the away-from-reactor ISFSI could exceed the EPA-recommended levels during some portions of construction and occasionally during operations. However, because of the limited duration of the construction period and the intermittent nature of the noise, the NRC concludes that the overall impacts associated with noise for the construction and short-term operation of the away-from-reactor ISFSI would be SMALL.

5.13.2 Long-Term Storage

The NRC assumes that a DTS is constructed as the duration and quantity of spent fuel in dry cask storage at an onsite storage facility increases. This facility would be used to retrieve and repackage spent fuel for aging management activities or to replace damaged canisters or casks identified during visual inspections. Section 2.1.4 provides a detailed description of the DTS.

Construction of a DTS would take approximately 1 to 2 years to complete. Noise levels generated during construction would be similar to those associated with initial construction of the ISFSI. Noise levels during construction could exceed the EPA recommendation at the nearest residence. Whether associated noise impacts could or would be mitigated could only be determined during a site-specific review. There would also be some additional traffic associated with the construction of the DTS but less than the traffic that would have occurred during initial construction.

Noise generated during operation of the ISFSI (e.g., cask handling, movements to and from pads, and routine maintenance and monitoring of the ISFSI) would be the same as during operations for the short-term timeframe, which were minimal.

Aging management would require the replacement of the ISFSI (e.g., casks, storage pads, and canister transfer building) and the DTS during the long-term storage timeframe. Storage facility and DTS replacement uses construction equipment that can generate noise levels similar to the original construction of the ISFSI. These noise levels could exceed the EPA recommendation during replacement activities. Whether associated noise impacts could or would be mitigated could only be determined during a site-specific review.

In conclusion, construction of the DTS, although temporary and representing a small portion of the overall timeframe for the spent fuel storage, does generate noise levels that could exceed EPA-recommended noise levels, as would activities to replace storage pads and other structures. However, these activities are temporary and noticeable noise levels would be limited to the nearest receptors. Generally for continued spent fuel storage, the operation noise levels, noise duration, and distance between the noise sources and receptors do not produce impacts noticeable to the surrounding community. Therefore, the NRC concludes that the overall noise impacts during the long-term storage timeframe at an away-from-reactor ISFSI would be SMALL.

5.13.3 Indefinite Storage

The environmental impacts of indefinite spent fuel storage would be similar to those described in Section 5.13.2. The same operations and maintenance activities described in Section 5.13.2 would occur repeatedly because the spent fuel would remain at the facility indefinitely. Based on this information, the NRC concludes that the overall noise impacts during indefinite storage at an away-from-reactor ISFSI would be SMALL.

5.14 Aesthetics

This section describes aesthetic resource impacts caused by the continued storage of spent fuel at an away-from-reactor ISFSI.

5.14.1 Short-Term Storage

Development of an away-from-reactor ISFSI would use a larger land area than any at-reactor ISFSI. The ISFSI would likely be sited and constructed in an area remote from population centers and areas sensitive to aesthetic concerns. On the other hand, the ISFSI could be sited and constructed in an area with no existing industrial facilities or similar land disturbance. Therefore, a site-specific analysis of the aesthetic impacts will be required for any proposed facility. The ISFSI could affect local scenic and visual quality to the extent its facility structures

Environmental Impacts of Away-From-Reactor Storage

and operations (e.g., buildings, dry storage pads and canisters, the rail line, and trains) are visible across any scenic waterbodies or from higher topographic elevations. Facility lighting could also affect the scenic quality of the area. If constructed in an area with no existing industrial development, there could also be viewshed impacts to the cultural landscape if historic properties are present within the area. Potential mitigation measures include use of shielded lights to minimize light diffusion at night, planting native vegetation or constructing earthen berms to screen the facility, and using paint colors that blend facility structures with the surrounding landscape, as discussed in the PFSF EIS (NRC 2001).

Further, the NRC considered the aesthetic impacts of spent fuel storage at a consolidated site as part of the PFSF EIS. This evaluation represents the result for an ISFSI built in an area with no previous industrial development. For the PFSF, the NRC found that the visual character of the area surrounding the site would have been negatively affected by development and operation of an industrial facility in an otherwise largely undeveloped rural landscape. The NRC determined that the scenic appeal of the site would have been noticeably changed when viewed from various locations. Because of these anticipated changes to the affected viewshed, the NRC found the aesthetic impacts from the construction and operation of the PFSF to be SMALL to MODERATE (NRC 2001).

For an away-from-reactor ISFSI at a different location, the impacts on aesthetic resources would be similar to those for the PFSF if it is built in a location with no previous industrial development. But the impacts could be SMALL if the ISFSI is built in a previously disturbed location (i.e., a brownfield site). Overall, the NRC concludes that the impacts on aesthetic resources would be SMALL to MODERATE.

5.14.2 Long-Term Storage

Aesthetic impacts from transferring and handling spent fuel and aging management activities at an away-from-reactor ISFSI are anticipated to be similar to the impacts described for the construction and short-term operation of the ISFSI described in Section 5.14.1. More specifically, periodic construction and demolition of facilities (including a DTS), although temporary, could cause an increase in aesthetic impacts compared to normal operation of the facility. However, because the replacement of the facilities would be placed near existing facilities and the activities and structures involved in the replacement are not expected to provide a significant change to what would exist prior to replacement, there would be no noticeable change to the impacts on aesthetic resources.

Because the periodic construction, demolition, and operation activities required for aging management would not significantly alter the pre-existing impacts of an away-from-reactor ISFSI, the NRC concludes that the environmental impacts on aesthetic resources due to long-term storage would be SMALL to MODERATE.

5.14.3 Indefinite Storage

If a repository is not available and away-from-reactor ISFSIs are developed, the activities that would be conducted at an away-from-reactor ISFSI would be the same as those described in Section 5.14.2. The same operations and maintenance activities described in Section 5.14.2 would occur repeatedly because the spent fuel would remain at the facility indefinitely. Based on this information, the NRC concludes that the aesthetic impacts during long-term storage at an away-from-reactor ISFSI would be SMALL to MODERATE.

5.15 Waste Management

This section describes impacts from low-level radioactive waste (LLW), mixed waste, and nonradioactive waste management and disposal resulting from the continued storage of spent fuel at an away-from-reactor ISFSI. See Section 3.14 for a description of the different types of waste and typical disposal methods for the wastes. See Section 4.15 for a description of the types and impacts of waste generated from the operation, maintenance, and replacement of an at-reactor ISFSI; they are the same types of waste produced by the operation, maintenance, and replacement of an away-from-reactor ISFSI. However, the away-from-reactor ISFSI is a much larger facility than an at-reactor ISFSI and therefore would generate a higher volume of waste.

5.15.1 Short-Term Storage

Assessment of the environmental impacts from the handling and disposal of LLW, mixed waste, and nonradioactive waste from an away-from-reactor ISFSI is informed by those described in the PFSF EIS (NRC 2001). The PFSF was designed with a capacity of 40,000 MTU and the NRC has assumed a facility of similar size and characteristics for the away-from-reactor ISFSI. Because a similar facility is assumed, the quantities of the various wastes generated at the ISFSI would also be similar to those identified for the PFSF. For purposes of estimating waste volumes, the canister transfer building would only handle canistered spent fuel. Therefore, the NRC assumes the amount of LLW produced during operation of a canister transfer building is no more than is produced at a DTS (i.e., 0.06m^3 [2ft^3] per canister), which handles bare spent fuel.

The construction of the PFSF would have included construction of major buildings (e.g., administration and laboratory) and 500 concrete storage pads. Construction activities would have generated excavation and construction debris, vegetation debris, and backfill (NRC 2001). For an away-from-reactor ISFSI, the construction debris would typically be disposed of at a local landfill. The excavation and backfill material could likely be reused for other purposes (e.g., building an earthen berm or to level low-lying areas). For the PFSF, the amount of soil excavated was estimated to be $153,500\text{ m}^3$ ($200,800\text{ yd}^3$). All of this material was expected to

Environmental Impacts of Away-From-Reactor Storage

remain onsite for other uses. This is consistent with NRC experience with other applications (e.g., new reactors), for which excavation materials are used or disposed of on the site.

Operation of an away-from-reactor ISFSI, like the PFSF, would involve limited waste-generating activities. The types of wastes generated would be similar to those for an onsite ISFSI, as described in Section 4.15.1, but on a larger scale. Small quantities of LLW would be generated during routine operation, including maintenance and environmental monitoring. This waste would be managed according to 10 CFR Part 20. Because (1) LLW would continue to be managed according to Federal regulations and (2) the disposal capacity for LLW is expected to be available when needed (see Section 1.8.3), the NRC determines the impacts from LLW management and disposal would be minor during short-term storage.

Operation and maintenance of the ISFSI would be expected to generate minimal to no mixed waste. Like other industrial facilities, small quantities of nonradioactive waste would be generated from routine operations and maintenance, including municipal waste and hazardous wastes, such as paint waste, pesticides, and cleaning supplies (NRC 2001). Sanitary wastes would be handled in accordance with regulatory requirements and disposed of at an appropriately permitted disposal facility. The wastes would be managed and disposed of according to regulatory requirements.

The NRC considered the impacts of solid and sanitary wastes due to spent fuel storage at a consolidated site as part of the PFSF EIS. This evaluation found that impacts from managing solid and sanitary wastes during construction and operation of the PFSF would have been SMALL (NRC 2001). Because of the small quantities of waste involved, the NRC concludes that the impacts of managing and disposing of LLW, mixed waste, and nonradioactive waste generated at an away-from-reactor ISFSI would be SMALL.

5.15.2 Long-Term Storage

Routine maintenance would continue to occur in the same manner as described in Section 5.15.1, generating minimal amounts of waste. Waste management and disposal activities related to the construction and operation of a DTS, and the replacement of canisters, storage casks, pads, the canister transfer building, DTS facilities, and other ISFSI structures, are discussed below. The repackaging of spent fuel, construction and operation of a DTS, and ISFSI and DTS replacement are not expected to generate mixed waste. However, if mixed waste is generated, it would be a small fraction of that generated by an operating nuclear power plant and it would be managed according to regulatory requirements. As well, any hazardous wastes generated during this timeframe would be a fraction of that generated at an operating power plant and would be managed according to regulatory requirements.

As described in Sections 4.15.2.1 and 4.15.2.3, the construction of a DTS would not be expected to generate LLW but would generate nonradioactive wastes similar to, but on a much

smaller scale than, the original construction of the ISFSI. The NRC expects that the material that is excavated for the DTS would be disposed of onsite.

For this analysis, because the activities associated with the replacement of the casks and ISFSI facilities are similar to decommissioning activities, the LLW impacts from the replacement of canisters, casks, and concrete pads are based on the decommissioning impacts considered in the PFSF EIS and other sources. As stated in Section 4.15.2.1, individual used canisters would be managed and disposed of as LLW and would have a compacted nominal volume of 1.3 m³ (1.7 yd³) (Transnuclear Inc. 2004). An estimated additional 0.06 m³ (2 ft³) would be generated during unloading and loading of each canister. Therefore, repackaging and replacing 4,000 canisters at an away-from-reactor ISFSI would generate approximately 5,400 m³ (7,100 yd³) of LLW. Once a canister has been removed from a cask, the licensee would survey the cask for residual radioactivity. If levels are below NRC limits, the casks can be disposed of as nonradioactive solid waste. If levels are above NRC limits, the cask material would be disposed of as LLW. Donnell (1998) estimated that the decommissioning of one cask at the PFSF would generate 0.34 m³ (0.45 yd³) of compacted LLW. Using this volume, the dismantling of 4,000 storage casks as part of ISFSI replacement would generate 1,360 m³ (1,780 yd³) of compacted LLW over an extended period of time. In addition, in its license application, PFS assumed at least 10 percent of the total storage pad surface area would need to be decontaminated. The decontamination of the 500 concrete storage pads at the PFSF would have generated an additional 8.5 m³ (11 yd³) of LLW (NRC 2001). If the storage pads are removed in their entirety, approximately 85,500 m³ (112,000 yd³) of material would need to be disposed of, either as LLW or nonradioactive waste (NRC 2001). As stated in Section 4.15.2.1, replacing the DTS would generate about 4 to 8 m³ (5 to 10 yd³) of LLW (DOE 1996). For purposes of estimating the volume of LLW generated by decontaminating the canister transfer building, which is not designed to handle bare spent fuel and would remain largely uncontaminated, the NRC assumes the amount of LLW is no more than is produced at a DTS (4 to 8 m³ [5 to 10 yd³]), which would handle bare spent fuel and could be contaminated.

Using the LLW volumes described above, the total volume of LLW generated during the long-term timeframe from replacement of canisters and decontamination of casks, ISFSI pads, DTS, and canister transfer building is about 6,800 m³ (8,900 yd³), which is comparable to the LLW volumes estimated for decommissioning a pressurized-water reactor (NRC 1996).

The NRC also estimated the volume of non-radioactive waste from the activities described above. In addition to the volume of LLW described above, the replacement of 4,000 casks would generate 162,000 m³ (212,000 yd³) of nonradioactive waste. The removal of those portions of the ISFSI pad which are decontaminated would generate about 85,500 m³ (112,000 yd³) (NRC 2001). The volume of non-radioactive waste from removal of the decontaminated DTS is estimated from the DTS TSAR to be 863 m³ (1,130 yd³) (DOE 1996).

Environmental Impacts of Away-From-Reactor Storage

Given that the canister transfer building is about 70 times larger than the DTS, the NRC estimates the volume of solid waste generated from removal of the canister transfer building would be about 60,000 m³ (78,000 yd³).

In summary, the total nonradioactive waste volume for replacement of storage casks, ISFSI pads, DTS, and canister transfer building is about 308,000 m³ (403,000 yd³), which is equivalent to about 740,000 MT (820,000 tons) of concrete. This amount of nonradioactive waste is a very small fraction of the 226 million MT (250.4 million tons) of municipal solid waste disposed of in 2011 (EPA 2013c), which would result in small impacts on total municipal solid waste capacity.

Although the exact amount of LLW and nonradioactive waste depends on the level of contamination, the quantity of waste generated from the replacement of the canisters, storage casks, concrete storage pads, DTS, and canister transfer building is still expected to be a comparable to the LLW generated during reactor decommissioning, which was previously determined to have a SMALL impact in the *Generic Environmental Impact Statement for License Renewal of Nuclear Plants* (NRC 2013a). Because (1) LLW would continue to be managed according to Federal regulations and (2) the disposal capacity for LLW is expected to be available when needed (see Section 1.8.3), the NRC determines the impacts from LLW management and disposal would be minor during the long-term timeframe. In addition, as described above, the amount of radioactive waste results in small impacts on municipal solid waste capacity. Therefore, the NRC determines that the potential environmental impacts from LLW, mixed waste, and nonradioactive waste for long-term storage at an away-from-reactor ISFSI would be SMALL for each waste stream.

5.15.3 Indefinite Storage

This section describes the potential environmental impacts from the management and disposal of LLW, mixed waste, and nonradioactive waste if a repository is not available to accept spent fuel. For this analysis, the NRC assumes that spent fuel would continue to be stored at an away-from-reactor ISFSI indefinitely. The waste-generating activities during this timeframe include the same activities discussed in Section 5.15.2 but with the activities occurring repeatedly. Those impacts were determined to be SMALL based on previous analyses that assumed a repository would be available.

The activities associated with the management and disposal of LLW and mixed waste from indefinite away-from-reactor storage of spent fuel would be similar to those described for the long-term timeframe. As stated in Section 1.8.3, it is expected that sufficient LLW disposal capacity will be made available when needed. Similar to the long-term timeframe, the NRC concludes the management and disposal of LLW and mixed waste could result in SMALL environmental impacts during indefinite storage of spent fuel. However, in this timeframe, because nonradioactive waste would continue to be generated indefinitely, even with continued implementation of and adherence to regulatory requirements, there could be noticeable impacts

on the local and regional landfill capacity for nonradioactive nonhazardous wastes. Therefore, the NRC determines that the environmental impacts from the indefinite management and disposal of nonradioactive waste would be SMALL to MODERATE.

5.16 Transportation

This section describes transportation impacts caused by the continued storage of spent fuel at an away-from-reactor ISFSI. Noise impacts from transportation activities are evaluated in Section 5.13 and air emissions are evaluated in Section 5.4. The transportation activities to move spent fuel to an away-from-reactor ISFSI are included in this section. In considering impacts related to the transportation of spent fuel from reactors to the away-from-reactor ISFSI, the NRC considers both the information in Table S-4⁶ (10 CFR 51.52) and the analysis of spent fuel transportation provided in the PFSF EIS (NRC 2001). Activities and impacts associated with moving spent fuel from the away-from-reactor ISFSI to a repository are addressed as cumulative impacts in Chapter 6.

5.16.1 Short-Term Storage

This analysis considers the impacts of transportation activities associated with construction and short-term operation of an away-from-reactor ISFSI on the affected environment beyond the site boundary. The environmental impacts evaluated include impacts on regional traffic from worker commuting, supply shipments, shipment of spent fuel to the ISFSI, and nonradiological and radiological waste shipments. Impacts on traffic from workers commuting to and from the away-from-reactor storage site depend on the size of the workforce, the capacity of the local road network, traffic patterns, and the availability of alternate commuting routes to and from the facility.

Construction transportation activities involve workers commuting to and from the site and shipping construction equipment, supplies, and waste materials. In the prior analysis of impacts from constructing the PFSF, the NRC concluded the initial construction phase (e.g., major buildings, approximately 25 percent of the proposed storage pads, the access road, a new rail siding, and new rail line) would have the largest transportation impacts during construction based on a total workforce of 255, split almost evenly between work on the site and work on the rail line (NRC 2001). The NRC considers the amount of transportation (additional number of vehicles on the road) from the PFSF EIS to be representative of the transportation for the away-from-reactor ISFSI because the facilities are the same size. For the first phase of construction

⁶ Table S-4 was prepared based on the assumption that spent fuel would be shipped from the reactor site to a reprocessing facility. However, because the analysis is addressing impacts that occur during transportation of the spent fuel, the type of facility to which it is being sent is not important. Therefore, the information provided by Table S-4 can be considered by the NRC in evaluating the impacts of the transportation of spent fuel from reactor sites to an away-from-reactor ISFSI.

Environmental Impacts of Away-From-Reactor Storage

for the PFSF, lasting about 18 months, the NRC concluded that the impacts on local transportation would have been SMALL to MODERATE. That analysis also found the transportation impacts of completing remaining facility construction would diminish along with a concurrent decline in the need for equipment, materials, and construction workers. The prior analysis concluded traffic impacts and increased wear and maintenance requirements would be highest (moderate impact) on local roads with low average daily traffic and less pronounced (small) for major transportation routes that have higher capacities. Specifically, peak construction traffic involving supply shipments and commuting workers was estimated at 450 vehicle trips per day (NRC 2001). This traffic was being added to local roads with annual average daily traffic counts between 325 and 565 vehicles per day (an increase in traffic ranging from 79 to 130 percent). This change in local traffic previously evaluated for the PFSF changed the level of service resulting in a conclusion of moderate impacts on traffic. Transportation of cask materials to construct 200 casks per year (an additional 6 truck trips per day) was also previously evaluated for the PFSF as not significantly adding to the daily traffic or projected impacts.

The impacts on traffic from construction of an away-from-reactor ISFSI at a different location are likely to be similar. The amount of additional traffic is not very large but because the ISFSI will likely be built in a remote location with limited existing roads, the impacts on local traffic may still be noticeable but not destabilizing. If the location of the ISFSI has an extensive existing road network, then the impacts may not be noticeable.

Construction of a rail line and siding to the PFSF would have required the movement of large quantities of excavated soils, ballast, and sub-ballast as well as the transportation of workers to construction areas and the same would be true for the away-from-reactor ISFSI, for which a similar rail line is assumed. The previous NRC impact analysis indicated that most materials and workers would be expected to travel to the site of the proposed rail siding by the interstate highways. Construction of the proposed rail line and siding would have required approximately 245,000 m³ (320,000 yd³) of ballast and sub-ballast (composed of crushed gravel or rock) obtained from existing commercial gravel pits in the area. Assuming a per-truck capacity of approximately 15.3 m³ (20 yd³) for movement of the ballast and sub-ballast, a total of approximately 32,000 two-way truck trips would have been required to transport the ballast and sub-ballast or 134 truck trips per day or approximately 13 vehicles per hour. The rail line construction workforce was estimated to be 125 workers contributing 250 vehicle trips per day for a total of 384 vehicle trips per day for rail line construction. This level of traffic was 4.5 percent of the interstate traffic; therefore, the NRC concluded impacts on transportation by construction of the rail line would have been small although temporarily adverse to feeder road traffic (i.e., noticeable but not destabilizing).

The impacts on traffic of building a rail line to an away-from-reactor ISFSI at a different location are likely to be similar. The amount of additional traffic is not very large, but because the ISFSI

will likely be built in a remote location with limited existing roads, the impacts on local traffic may still be noticeable but not destabilizing. If the location of the ISFSI has an extensive existing road network, then the impacts may not be noticeable.

Operation of an away-from-reactor ISFSI would result in small impacts on the local transportation system due to daily commuting of workers and shipment of fabricated steel liners for the storage casks and spent fuel transportation packages. The NRC previously estimated for the PFSF that an operations workforce of 43 workers would commute each day using individual private vehicles or light trucks. These workers would account for an increase of 86 vehicle trips per day on local roads during operations. The previous NRC analysis of impacts of the PFSF concluded this decrease in the volume of traffic generated by the storage facility relative to construction activities would not result in any degradation of the level of service on local roads (NRC 2001). Because of the small number of trips involved, the NRC concludes that the traffic impacts for an away-from-reactor ISFSI at a different location would also not be noticeable.

During the operation of the away-from-reactor ISFSI, spent fuel would be shipped from power plants to the facility. These shipments would be required to comply with applicable NRC and U.S. Department of Transportation (DOT) regulations for the transportation of radioactive materials in 10 CFR Parts 71 and 73 and 49 CFR Parts 107, 171—180, 390—397, as appropriate to the mode of transport. The radiological impacts on the public and workers of spent fuel shipments from a reactor have been previously evaluated by the NRC and found to be SMALL in several evaluations. A generic impact determination in 10 CFR 51.52, Table S-4, and the supporting analysis (AEC 1972) concluded that the environmental impacts of transportation of fuel and waste to and from a light water reactor under normal operations of transport and accidents in transport would be small.

The results of subsequent analyses of transportation impacts in *Final Environmental Statement on Transportation of Radioactive Material by Air and Other Modes* (NRC 1977) and *Reexamination of Spent Fuel Shipment Risk Estimates* (Sprung et al. 2000) confirmed that spent fuel transportation impacts are small. Additional site-specific analyses of transportation impacts for power plants that did not meet the conditions of 10 CFR 51.52 also concluded that the transportation radiological impacts would be small (NRC 2006c, 2008b, 2011a-d, 2013c). The NRC recently calculated spent fuel transportation risks for individual shipments under incident-free and accident conditions in *Spent Fuel Transportation Risk Assessment Final Report* (NRC 2014) based on current models, data, and assumptions. The analysis modeled transportation package response to accident conditions, such as impact force and fire, and calculated risks considering a range of truck and rail accidents of different severities, including those involving no release or loss of shielding, loss of shielding only, or loss of shielding and release. That analysis reconfirmed that the radiological impacts from spent fuel transportation conducted in compliance with NRC regulations are low. The NRC concluded that the

Environmental Impacts of Away-From-Reactor Storage

regulations for transportation of radioactive material are adequate to protect the public against unreasonable risk of exposure to radiation from spent fuel packages in transport (NRC 2014).

Considering that an away-from-reactor ISFSI would also receive shipments of spent fuel from more than one power plant, the radiological and nonradiological impacts from a comparable transportation scenario were previously evaluated for the PFSF (NRC 2001). That analysis calculated incident-free and accident risks from the shipment of 4,000 spent fuel packages, transported over a representative route from Maine to Utah over a 20-year period, and concluded the radiological impacts would have been SMALL. The resulting cumulative dose to the maximally exposed individual at the end of the 20-year period was 0.022 mSv (2.2 mrem).⁷ The maximally exposed individual is an individual that is assumed for the purpose of bounding to be exposed to the radiation from all shipments. By comparison, NRC regulations at 10 CFR 20.1301 limit the annual radiation dose to any member of the public resulting from any licensed activity to 1 mSv (100 mrem). The PFSF incident-free and accident risk results were bounded by or comparable to results in 10 CFR 51.52, Table S-4, or the *Final Environmental Statement on Transportation of Radioactive Material by Air and Other Modes* (NRC 1977). Based on the PFSF analysis, the NRC concludes in the present analysis that the additional accumulated impacts from transportation of the entire inventory of spent fuel from multiple reactors to an away-from-reactor ISFSI would also be minor.

The operation of the away-from-reactor ISFSI would generate a small amount of LLW (e.g., used personal protection equipment) that would result in infrequent waste shipments to a licensed disposal facility. The small and infrequent number of shipments and compliance with NRC and the DOT packaging and transportation regulations would also limit potential worker and public radiological and nonradiological impacts from these waste shipments. Based on this analysis, the NRC concludes the impacts on traffic and to public and worker radiological and nonradiological safety from LLW shipments resulting from spent fuel storage activities beyond the licensed life of reactor operation would be small.

Based on the factors discussed above, the NRC concludes the impacts on traffic and public and worker radiological and nonradiological safety from construction and operation activities for an away-from-reactor ISFSI during short-term storage would be SMALL to MODERATE. The potential for a MODERATE impact is related to traffic and would depend on the characteristics at a particular site.

5.16.2 Long-Term Storage

During the long-term storage timeframe, the NRC assumes aging management activities would begin to identify stored spent fuel canisters requiring replacement. To evaluate the potential

⁷ By way of comparison, the average annual dose to individuals from natural background radiation (e.g., solar radiation and radon) is 3.11 mSv/yr (311 mrem/yr) (NCRP 2009).

impacts, the NRC assumes a spent fuel DTS would be constructed to execute the replacement of canisters and casks. This facility would provide the capability to repackage spent fuel to replace damaged canisters or casks identified during regular inspections or aging management activities. The longer duration of storage is assumed to require eventual replacement of the away-from-reactor ISFSI and DTS facilities during the long-term storage timeframe. These replacement activities would generate additional waste material shipments.

The construction of a DTS would likely involve a smaller temporary workforce than the original construction workforce. A previously reviewed proposal to construct a spent fuel transfer facility at the Idaho National Engineering Laboratory (NRC 2004) estimated a construction workforce of 250 workers that would be employed for 2 years. Because the proposed Idaho transfer facility was designed to transfer a larger variety wastes than would be handled at an away-from-reactor storage facility, the NRC assumes the Idaho facility bounds the impacts of constructing a DTS at an away-from-reactor ISFSI. The resulting daily two-way traffic trips from this workforce (500 trips) would be comparable to the construction workforce traffic evaluated in Section 5.16.1 for initial storage facility construction and therefore traffic impacts would range from not noticeable to noticeable but not destabilizing. Operation of the dry spent fuel transfer facility would involve fewer workers than the construction workforce (60 workers were previously projected for operation of the Idaho transfer facility [NRC 2004]), and therefore the commuting traffic impacts during the operational period would be minor.

The operation of the DTS would involve shipment of materials including new canisters and would generate a small amount of LLW (e.g., used canisters and used personal protection equipment) that would result in infrequent waste shipments to a licensed disposal facility. The small and infrequent number of shipments and compliance with NRC and DOT packaging and transportation regulations would also limit potential worker and public radiological and nonradiological impacts from these waste shipments. Based on this analysis, the NRC concludes the impacts on traffic and to public and worker radiological and nonradiological safety from LLW shipments resulting from spent fuel storage activities during the long-term storage timeframe would be minimal.

The replacement of the storage facility, DTS, and an increase in repackaging would generate additional nonradiological and LLW that would need to be shipped offsite for disposal. As described in Section 5.15.2, the estimated quantity of waste from replacement activities would be about 315,000 m³ (412,000 yd³) of nonhazardous waste or LLW. Assuming this waste is shipped in roll-off containers with a capacity of 15 m³ (20 yd³), the total number of truck shipments estimated is 20,600. If replacement were phased over a 5-year period and shipping occurred 5 days per week, 16 shipments per day would be needed. The activities would not significantly increase the magnitude of traffic generated by storage operations occurring each year, and operational transportation impacts would continue to be minor.

Environmental Impacts of Away-From-Reactor Storage

Based on the preceding analysis, the overall transportation impacts of continued operations of the away-from-reactor ISFSI during the long-term storage timeframe would be SMALL to MODERATE. The potential for a MODERATE impact is related to traffic and would depend on the characteristics at a particular site.

5.16.3 Indefinite Storage

Assuming no repository becomes available, spent fuel would be stored indefinitely in the away-from-reactor ISFSI. Annual transportation activities and associated environmental impacts would be similar to that analyzed for storage facility operations and DTS construction and operations evaluated in Section 5.16.2. The same operations and maintenance activities described in Section 5.16.2 would occur repeatedly because the spent fuel would remain at the facility indefinitely. Based on this information, the NRC concludes that the transportation impacts during indefinite storage at an away-from-reactor ISFSI would be SMALL to MODERATE. The potential for a MODERATE impact is related to traffic and would depend on the characteristics at a particular site.

5.17 Public and Occupational Health

This section describes public and occupational health impacts caused by the continued storage of spent fuel at an away-from-reactor ISFSI. For the purposes of assessing radiological impacts, impacts are considered to be SMALL if releases and doses do not exceed dose limits prescribed by NRC regulations. This definition of SMALL applies to occupational doses as well as to doses to individual members of the public.

Transportation-related public and occupational health impacts are addressed in Section 5.16.

5.17.1 Short-Term Storage

In the PFSF EIS (NRC 2001), the NRC examined human health impacts related to construction and operation of an away-from-reactor ISFSI. The analysis addressed in detail the human health impacts resulting from construction, operation, and potential accidents at the proposed PFSF site. This included nonradiological impacts from construction and operation of the proposed PFSF, as well as analysis of the radiological impacts from the spent fuel stored at the facility, including potential radiological accidents and their consequences. The type and frequency of nonradiological injuries and the types of pollutant emissions at an away-from-reactor ISFSI would be similar to those for the PFSF because of the similarities between the facilities. The types of radiological releases from the two facilities would also be similar for the same reason.

The nonradiological health impacts from the construction of a facility of this size include the normal hazards associated with construction, such as pollutants (e.g., dust), and fatal and

nonfatal occupational injuries, such as falls or overexertion. The detailed analysis in the PFSF EIS used extensive data from the Bureau of Labor Statistics and the Occupational Safety and Health Administration, as well as discussion of the requirements of the Occupational Safety and Health Administration's General Industry Standards (29 CFR Part 1910) and Construction Industry Standards (29 CFR Part 1926) to conclude that the nonradiological health impacts would have been SMALL. The results were typical for an industrial facility of this size and would also apply to a similarly sized away-from-reactor ISFSI at any location. Impacts of nonradiological accidents during operations would be even less because of the smaller workforce and because activities carried out during operations will generally be lower risk activities (e.g., monitoring). Therefore, the NRC concludes that human health impacts from construction and operation of the ISFSI would be minor.

Radiological impacts at an away-from-reactor ISFSI would not occur until operation commenced and spent fuel storage casks were brought on site. The detailed analyses in the PFSF EIS used the review and evaluation of the PFSF Safety Analysis Report to assess the radiological impacts on the general public (i.e., potential dose to a hypothetical maximally exposed individual located at the boundary of the proposed facility as well as known nearby residents) and estimated dose to occupational personnel.

The analyses presented in the PFSF EIS (NRC 2001) provide evidence that public and occupational doses would have been maintained significantly below the dose limits established by 10 CFR Part 72 and 10 CFR Part 20. The NRC assumes that an away-from-reactor ISFSI at any site has the same spent fuel capacity and a similar physical size; therefore, doses to workers and to the public would be similar to those calculated for the PFSF. The NRC concludes that public and occupational health impacts would be SMALL.

5.17.2 Long-Term Storage

As discussed in the previous section, in the PFSF EIS (NRC 2001) the NRC examined human health impacts related to construction and operation of an away-from-reactor ISFSI. The analysis addressed in detail the public and occupational human health impacts resulting from construction, operation, and potential accidents at the proposed PFSF site. The occupational tasks were grouped into four categories consisting of (1) handling (i.e., receiving, transferring, and moving) of the spent fuel canisters and casks; (2) security, inspection, and maintenance activities; (3) administration and management; and (4) facility construction. The analyses for categories 1, 2, and 3 provide a similar analysis for the transferring, handling, and aging management activities that would be required for long-term storage of spent fuel being addressed by this GEIS. The analyses presented in the PFSF EIS (NRC 2001) provide evidence that public and occupational doses would be maintained significantly below the dose limits established by 10 CFR Part 72 and 10 CFR Part 20. In addition, these regulations would also require a licensed away-from-reactor ISFSI to maintain an ALARA (as low as is reasonably achievable) program, which would likely reduce the doses described in the PFSF EIS (NRC

Environmental Impacts of Away-From-Reactor Storage

2001). The NRC assumes that an away-from-reactor ISFSI at any site has the same spent fuel capacity and a similar physical size; therefore, doses to workers and to the public would be similar to those calculated for the PFSF. The NRC concludes that public and occupational health impacts from operations during the long-term storage timeframe would be minor.

During the long-term storage timeframe, the NRC expects that the licensee would have to build a DTS for repackaging of spent fuel canisters. The operation of the DTS would involve increased doses to workers and a very small increase in dose levels at the site boundary (estimated at roughly 0.8 km [0.5 mi] based on the size of the site). However, the licensee would still be required to comply with the dose limits established by 10 CFR Part 72 and 10 CFR Part 20. In addition, the NRC assumes that the casks, pads, canister transfer building, and DTS would require replacement during the long-term storage timeframe. The health impacts related to these activities would be similar to those for the original construction of the facility.

Based on the information above, the NRC concludes that the public and occupational health impacts of ISFSI operations and construction and demolition activities during the long-term timeframe of storage would be SMALL.

5.17.3 Indefinite Storage

The public and occupational impacts of continuing to store spent fuel without a repository would be similar to those described in Section 5.17.2. The types of activities (operation, maintenance, and replacement) and associated human health impacts would remain the same. The main difference is that these activities would be repeated over a longer period of time. Based on this information, the NRC concludes that the impacts on human health during long-term storage at an away-from-reactor ISFSI would be SMALL.

5.18 Environmental Impacts of Postulated Accidents

In this section, the NRC considers the environmental impacts of postulated accidents involving continued storage of spent fuel at an away-from-reactor ISFSI. The fuel will be stored in dry storage casks licensed by the NRC. As discussed in Chapter 1, the NRC assumes that a DTS would be constructed to facilitate canister and cask replacement for long-term and indefinite storage. The consequences of accidents for a dry cask storage facility are summarized in Sections 4.18.1.2 and 4.18.2.2. The types and consequences of accidents for the away-from-reactor ISFSI are represented by the Chapter 4 results because of the similarities between the at-reactor ISFSIs and any away-from-reactor ISFSI (i.e., because the types of casks used to store the fuel and the process for licensing those casks are the same).

This section of the GEIS follows a different format than the rest of the document. Because the impacts from accidents are substantially the same across the three timeframes—short-term, long-term, and indefinite—the GEIS presents the various accident types only once.

NRC regulations at 10 CFR Part 72, "Licensing Requirements for the Independent Storage of Spent Nuclear Fuel, High-Level Radioactive Waste, and Reactor-Related Greater than Class C Waste," require that structures, systems, and components important to safety shall be designed to withstand the effects of natural phenomena (such as, earthquakes, tornadoes, hurricanes) and human-induced events without loss of capability to perform their safety functions. NRC siting regulations at 10 CFR Part 72, Subpart E, "Siting Evaluation Factors," also require applicants to consider, among other things, physical characteristics of sites that are necessary for safety analysis or that may have an impact on plant design (e.g., the design earthquake). These characteristics are to be identified and characterized so that they may be taken into consideration when determining the acceptability of the site and design criteria of the facility.

In the PFSF EIS, the NRC examined environmental impacts from accidents at the proposed PFSF. This included two events (i.e., extreme winds and 100 percent air duct blockage) that could cause higher-than-normal radiation exposures to workers. In that analysis, the NRC postulated that the high-wind event resulted in wind-borne missiles that damaged the concrete overpack, which resulted in reduced shielding. The reduced shielding would cause slightly higher occupational doses and only negligible increases in radiation doses to a member of the public at the boundary of the owner-controlled area. The NRC considered the occupational doses that would be received upon transfer of the undamaged canister to a replacement cask. The NRC estimated that the dose from transfer operations would result in a collective occupational dose of 2.47 person-mSv (247 person-mrem). In the second event involving blocked vents, the NRC estimated that the dose to a worker that removes the blockage from the vents would be 0.586 mSv (58.6 mrem) to the hands and forearms, and 0.386 mSv (38.6 mrem) to the chest, which is below regulatory limits for workers (NRC 2001). Because of the similarities between the PFSF and any away-from-reactor ISFSI (i.e., because the types of casks used to store the fuel and the process for licensing those casks are the same), the results would be similar to those for the PFSF. Therefore, the impacts of these accidents would be minor.

In addition to the credible events described above, for the PFSF the NRC also considered an accident, not considered credible, in which a canister leaks. The NRC estimated that the resulting total effective dose equivalent resulting from a 30-day leak to an individual at the owner-controlled area boundary was 0.76 mSv (76 mrem). Radiation doses after the first 30 days that result from radioactive material deposited on the ground were 0.027 mSv/yr (2.7 mrem/yr) (NRC 2001). These values are below dose limits in 10 CFR Part 20 and 10 CFR 72.106. As a result, the NRC determined that these impacts would have been SMALL (NRC 2001). Because of the similarities between the facilities, the results would be similar for any away-from-reactor ISFSI and the impacts would be minor.

While the results described from the PFSF EIS are specific to that facility, the PFSF and away-from-reactor ISFSI are similar and subject to the same regulations for casks and operations.

The NRC therefore concludes that these results are representative of the impacts for an away-from-reactor ISFSI at a different location. Therefore, the NRC concludes that the impacts of postulated accidents would be SMALL during the three storage timeframes.

5.19 Potential Acts of Sabotage or Terrorism

Section 4.19 provides background regarding the NRC approach to addressing acts of terrorism in relation to dry cask storage. That information is also applicable to an away-from-reactor ISFSI. As with the accident impacts analysis in Section 5.18, the impacts from terrorist acts are substantially the same across the three timeframes—short-term, long-term, and indefinite—and are therefore discussed only once.

The same safeguards regulations (10 CFR Part 72, Subpart H) apply to both an at-reactor ISFSI under a site-specific license and an away-from-reactor ISFSI. Safeguard requirements at at-reactor specifically licensed ISFSIs are described in Section 4.19.2 of this GEIS. In that section, the NRC concluded that both the probability and consequences of a successful attack on an at-reactor ISFSI are low and, therefore, the environmental risk is SMALL. Therefore, the NRC concludes that the results from Section 4.19.2 would also be applicable to an away-from-reactor ISFSI, and the associated impacts would be SMALL during the three storage timeframes.

5.20 Summary

The impact levels determined by the NRC in the previous sections for away-from-reactor dry cask storage of spent fuel are summarized in Table 5-1. For most impact areas, the impact levels are denoted as SMALL, MODERATE, and LARGE as a measure of their expected adverse environmental impacts. In other impact areas, the impact levels are denoted according to the types of findings required under applicable regulatory or statutory schemes (e.g., “disproportionately high and adverse” for environmental justice impacts).

For a number of the resource areas, the impact determinations for all three timeframes are SMALL. For air quality and terrestrial ecology, there is the potential for a MODERATE impact during the construction of the ISFSI. For environmental justice, special status species and habitats, and historic and cultural resources, the results are highly site-specific. While it is possible the ISFSI could be built and operated with no noticeable impacts on these resources, a definitive conclusion cannot be drawn in this GEIS. For socioeconomics (taxes), aesthetics, and traffic, there are impacts that could be greater than SMALL that will continue throughout the existence of the ISFSI. The tax impacts are beneficial in nature. Finally, there is the potential for a MODERATE impact from the disposal of nonradioactive waste in the indefinite timeframe if that waste exceeds the capacity of nearby landfills.

Environmental Impacts of Away-From-Reactor Storage

Table 5-1. Summary of Environmental Impacts of Continued Away-from-Reactor Storage

Resource Area	Short-Term Storage	Long-Term Storage	Indefinite Storage
Land Use	SMALL	SMALL	SMALL
Socioeconomics	SMALL (adverse) to LARGE (beneficial)	SMALL (adverse) to LARGE (beneficial)	SMALL (adverse) to LARGE (beneficial)
Environmental Justice	Disproportionately high and adverse impacts are not expected		
Air Quality	SMALL to MODERATE	SMALL	SMALL
Climate Change	SMALL	SMALL	SMALL
Geology and Soils	SMALL	SMALL	SMALL
Surface-Water			
Quality	SMALL	SMALL	SMALL
Consumptive Use	SMALL	SMALL	SMALL
Groundwater			
Quality	SMALL	SMALL	SMALL
Consumptive Use	SMALL	SMALL	SMALL
Terrestrial Resources	SMALL to MODERATE	SMALL	SMALL
Aquatic Ecology	SMALL	SMALL	SMALL
Special Status Species and Habitats	Impacts for Federally listed threatened and endangered species and EFH would be determined as part of the consultations for the ESA and the Magnuson–Stevens Fishery Conservation and Management Act		
Historic and Cultural Resources	SMALL to LARGE	SMALL to LARGE	SMALL to LARGE
Noise	SMALL	SMALL	SMALL
Aesthetics	SMALL to MODERATE	SMALL to MODERATE	SMALL to MODERATE
Waste Management			
LLW	SMALL	SMALL	SMALL
Mixed Waste	SMALL	SMALL	SMALL
Nonradioactive Waste	SMALL	SMALL	SMALL to MODERATE
Transportation			
Traffic	SMALL to MODERATE	SMALL to MODERATE	SMALL to MODERATE
Health	SMALL	SMALL	SMALL
Public and Occupational Health	SMALL	SMALL	SMALL
Accidents	SMALL	SMALL	SMALL
Sabotage or Terrorism	SMALL	SMALL	SMALL

5.21 References

10 CFR Part 20. *Code of Federal Regulations*, Title 10, *Energy*, Part 20, “Standards for Protection Against Radiation.” Washington, D.C.

10 CFR Part 51. *Code of Federal Regulations*, Title 10, *Energy*, Part 51, “Environmental Protection Regulations for Domestic Licensing and Related Regulatory Functions.” Washington, D.C.

10 CFR Part 71. *Code of Federal Regulations*, Title 10, *Energy*, Part 71, “Packaging and Transportation of Radioactive Material.” Washington, D.C.

10 CFR Part 72. *Code of Federal Regulations*, Title 10, *Energy*, Part 72, “Licensing Requirements for the Independent Storage of Spent Nuclear Fuel, High-Level Radioactive Waste, and Reactor-Related Greater Than Class C Waste.” Washington, D.C.

10 CFR Part 73. *Code of Federal Regulations*, Title 10, *Energy*, Part 73, “Physical Protection of Plants and Materials.” Washington, D.C.

29 CFR Part 1910. *Code of Federal Regulations*, Title 29, *Labor*, Part 1910, “Occupational Safety and Health Standards.” Washington, D.C.

29 CFR Part 1926. *Code of Federal Regulations*, Title 29, *Labor*, Part 1926, “Safety and Health Regulations for Construction.” Washington, D.C.

36 CFR Part 60. *Code of Federal Regulations*, Title 36, *Parks, Forests, and Public Property*, Part 60, “National Register of Historic Places.” Washington, D.C.

36 CFR Part 800. *Code of Federal Regulations*, Title 36, *Parks, Forests, and Public Property*, Part 800, “Protection of Historic Properties.” Washington, D.C.

40 CFR Part 51. *Code of Federal Regulations*, Title 40, *Protection of the Environment*, Part 51, “Requirements for Preparation, Adoptions, and Submittal of Implementation Plans.” Washington, D.C.

40 CFR Part 52. *Code of Federal Regulations*, Title 40, *Protection of the Environment*, Part 52, “Approval and Promulgation of Implementation Plans.” Washington, D.C.

40 CFR Part 93. *Code of Federal Regulations*, Title 40, *Protection of the Environment*, Part 93, “Determining Conformity of Federal Actions to State or Federal Implementation Plans.” Washington, D.C.

Environmental Impacts of Away-From-Reactor Storage

49 CFR Part 107. *Code of Federal Regulations*, Title 49, *Transportation*, Part 107, “Hazardous Materials Program Procedures.” Washington, D.C.

49 CFR Parts 171–180. *Code of Federal Regulations*, Title 49, *Transportation*, Parts 171–180, “Hazardous Materials Regulations.” Washington, D.C.

49 CFR Parts 390–397. *Code of Federal Regulations*, Title 49, *Transportation*, Parts 390–397, “Federal Motor Carrier Safety Regulations.” Washington, D.C.

50 CFR Part 402. *Code of Federal Regulations*, Title 50, *Wildlife and Fisheries*. “Interagency Cooperation—Endangered Species Act of 1973, as Amended.” Washington, D.C.

50 CFR Part 600. *Code of Federal Regulations*, Title 50, *Wildlife and Fisheries*. “Magnuson-Stevens Act Provisions.” Washington, D.C.

69 FR 52040. August 24, 2004. “Policy Statement on the Treatment of Environmental Justice Matters in NRC Regulatory and Licensing Actions.” *Federal Register*, U.S. Nuclear Regulatory Commission, Washington, D.C.

AEC (U.S. Atomic Energy Commission). 1972. *Environmental Survey of Transportation of Radioactive Materials to and From Nuclear Power Plants*. WASH–1238, Washington, D.C. Available at http://www.osti.gov/energycitations/product.biblio.jsp?osti_id=4569134.

Bald and Golden Eagle Protection Act of 1940, as amended. 16 USC 668-668d *et seq.*

Clean Air Act, as amended. 42 USC 7401 *et seq.*

Clean Water Act (See Federal Water Pollution Control Act of 1972).

Coastal Zone Management Act of 1972, as amended. 16 USC 1451 *et seq.*

DOE (U.S. Department of Energy). 2002. *Final Environmental Impact Statement for a Geologic Repository for the Disposal of Spent Nuclear Fuel and High-Level Radioactive Waste at Yucca Mountain, Nye County, Nevada*. DOE/EIS–0250, Office of Civilian Radioactive Waste Management, Washington, D.C. Accession No. ML14024A327.

DOE (U.S. Department of Energy). 2008. *Final Supplemental Environmental Impact Statement for a Geologic Repository for the Disposal of Spent Nuclear Fuel and High-Level Radioactive Waste at Yucca Mountain, Nye County, Nevada*. DOE/EIS–0250F–S1, Washington, D.C. Accession No. ML081750191.

Environmental Impacts of Away-From-Reactor Storage

DOE (U.S. Department of Energy). 2013. *Strategy for the Management and Disposal of Used Nuclear Fuel and High-Level Radioactive Waste*. Washington, D.C. Accession No. ML13011A138.

Donnell, J. 1998. *Response to RAI LA 1-6 Private Fuel Storage Facility Docket No. 72-22/TAC No. L22462 Private Fuel Storage LLC*. Private Fuel Storage LLC, La Crosse, Wisconsin. Accession No. ML010260218.

Endangered Species Act (ESA), as amended. 16 USC 1531 *et seq.*

EPA (U.S. Environmental Protection Agency). 1974. *Information on Levels of Environmental Noise Requisite to Protect Public Health and Welfare with an Adequate Margin of Safety*, EPA550/9-74-004, Research Triangle Park, North Carolina. Accession No. ML101790269.

EPA (U.S. Environmental Protection Agency). 2013a. "Clean Energy: Calculations and References." Washington, D.C. Accession No. ML13205A377.

EPA (U.S. Environmental Protection Agency). 2013b. *Inventory of U.S. Greenhouse Gas Emissions and Sinks: 1990–2011*. EPA 430-R-13-001, Washington, D.C. Accession No. ML13331A473.

EPA (U.S. Environmental Protection Agency). 2013c. *Municipal Solid Waste in the United States: 2011 Facts and Figures*. EPA 530-R-13-001, Washington, D.C. Available at http://www.epa.gov/osw/nonhaz/municipal/pubs/MSWcharacterization_fnl_060713_2_rpt.pdf.

Federal Water Pollution Control Act of 1972, as amended (also referred to as the Clean Water Act). 33 USC 1251 *et seq.*

Fish and Wildlife Coordination Act of 1934, as amended. 16 USC 661-667e *et seq.*

Foster Wheeler (Foster Wheeler Environmental Corporation). 2003. Letter from D.I. Rogers, Jr. to NRC, dated November 14, 2003, regarding "Idaho Spent Fuel (ISF) Facility Submittal of Amendment 3 to License Application, Docket No. 72.25, TAC No. L23389." Morris Plains, New Jersey. Accession No. ML033240044.

FWS/NMFS (Fish and Wildlife Service/National Marine Fisheries Service). 1998. *Endangered Species Act Consultation Handbook: Procedures for Conducting Consultation and Conference Activities Under Section 7 of the Endangered Species Act*. Washington, D.C. Accession No. ML12325A215.

LES (Louisiana Energy Services, LLC). 1998. Letter from R.J. Jensen to S.A. Jackson, dated April 22, 1998, "In the Matter of Louisiana Energy Services, Docket No. 70-3070-ML." ADAMS Legacy Library Accession No. 9804240190.

Environmental Impacts of Away-From-Reactor Storage

Magnuson-Stevens Fishery Conservation and Management Act of 1976, as amended. 16 USC 1801 *et seq.*

Marine Mammal Protection Act of 1972, as amended. 16 USC 1361 *et seq.*

Migratory Bird Treaty Act of 1918, as amended. 16 USC 703-712 *et seq.*

National Environmental Policy Act of 1969 (NEPA), as amended. USC 4321 *et seq.*

National Historic Preservation Act (NHPA), as amended. 16 USC 470 *et seq.*

NCRP (National Council on Radiation Protection and Measurements). 2009. *Ionizing Radiation Exposure of the Population of the United States*. Report 160, Bethesda, Maryland.

NRC (U.S. Nuclear Regulatory Commission). 1977. *Final Environmental Statement on Transportation of Radioactive Material by Air and Other Modes*. NUREG-0170, Washington, D.C. Accession No. ML12192A283.

NRC (U.S. Nuclear Regulatory Commission). 1998. *In the Matter of Louisiana Energy Services, L.P. (Claiborne Enrichment Center)*. CLI-98-3, 47 NRC 77, Washington, D.C. Accession No. ML020560604.

NRC (U.S. Nuclear Regulatory Commission). 2001. *Final Environmental Impact Statement for the Construction and Operation of an Independent Spent Fuel Storage Installation on the Reservation of the Skull Valley Band of Goshute Indians and the Related Transportation Facility in Tooele County, Utah*. NUREG-1714, Volume 1, Washington, D.C. Accession No. ML020150170.

NRC (U.S. Nuclear Regulatory Commission). 2002. *Final Generic Environmental Impact Statement for Decommissioning of Nuclear Facilities, Supplement 1 Regarding the Decommissioning of Nuclear Power Reactors*. NUREG-0586, Volumes 1 and 2, Washington, D.C. Accession Nos. ML023470327, ML023500228.

NRC (U.S. Nuclear Regulatory Commission). 2004. *Environmental Impact Statement for the Proposed Idaho Spent Fuel Facility at the Idaho National Engineering and Environmental Laboratory in Butte County, Idaho*. NUREG-1773, Washington, D.C. Accession No. ML040490135.

NRC (U.S. Nuclear Regulatory Commission). 2006a. Letter from W.H. Ruland to J.D. Parkyn dated February 21, 2006, regarding "Issuance of Materials License No. SNM-2513 for the Private Fuel Storage Facility (TAC No. L23821)." Washington, D.C. Accession No. ML060450412.

Environmental Impacts of Away-From-Reactor Storage

NRC (U.S. Nuclear Regulatory Commission). 2006b. *Consolidated Decommissioning Guidance: Decommissioning Process for Materials Licensees*. NUREG–1757, Revision 2, Washington, D.C. Accession No. ML063000243.

NRC (U.S. Nuclear Regulatory Commission). 2006c. *Final Environmental Impact Statement for an Early Site Permit (ESP) at the North Anna ESP Site*. NUREG–1811, Volume 1, Washington, D.C. Accession No. ML063480261.

NRC (U.S. Nuclear Regulatory Commission). 2008a. *U.S. Nuclear Regulatory Commission Staff's Adoption Determination Report for the U.S. Department of Energy's Environmental Impact Statements for the Proposed Geologic Repository at Yucca Mountain*. Washington, D.C. Accession No. ML082420342.

NRC (U.S. Nuclear Regulatory Commission). 2008b. *Final Environmental Impact Statement for an Early Site Permit (ESP) at the Vogtle Electric Generating Plant Site*. NUREG–1872, Volume 1, Washington, D.C. Accession No. ML082240145.

NRC (U.S. Nuclear Regulatory Commission). 2011a. *Final Environmental Impact Statement for the Combined License (COL) for Calvert Cliffs Nuclear Power Plant Unit 3*. NUREG–1936, Volumes 1 and 2, Washington, D.C. Accession Nos. ML11129A167, ML11129A179.

NRC (U.S. Nuclear Regulatory Commission). 2011b. *Final Environmental Impact Statement for the Combined Licenses (COLs) for South Texas Project Electric Generating Station Units 3 and 4*. NUREG–1937, Washington, D.C. Accession No. ML11049A000.

NRC (U.S. Nuclear Regulatory Commission). 2011c. *Final Environmental Impact Statement for the Combined Licenses (COLs) for Virgil C. Summer Nuclear Station, Units 2 and 3*. NUREG–1939, Volumes 1 and 2, Washington, D.C. Accession Nos. ML11098A044, ML11098A057.

NRC (U.S. Nuclear Regulatory Commission). 2011d. *Final Environmental Impact Statement for Combined Licenses (COLs) for Comanche Peak Nuclear Power Plant Units 3 and 4*. NUREG–1943, Volumes 1 and 2, Washington, D.C. Accession Nos. ML11131A001, ML11131A002.

NRC (U.S. Nuclear Regulatory Commission). 2012. *Environmental Impact Statement for Combined Licenses (COLs) for Levy Nuclear Plant Units 1 and 2—Final Report*. NUREG–1941, Volume 1, Washington, D.C. Accession No. ML12100A063.

NRC (U.S. Nuclear Regulatory Commission). 2013a. *Generic Environmental Impact Statement for License Renewal of Nuclear Plants*. NUREG–1437, Revision 1, Washington, D.C. Accession No. ML13107A023.

Environmental Impacts of Away-From-Reactor Storage

NRC (U.S. Nuclear Regulatory Commission). 2013b. *Attachment 1—Staff Guidance for Greenhouse Gas and Climate Change Impacts for New Reactor Environmental Impact Statements*. COL/ESP-ISG-026, Washington, D.C. Accession No. ML12326A811.

NRC (U.S. Nuclear Regulatory Commission). 2013c. *Final Environmental Statement for the Combined License (COL) for Enrico Fermi Unit 3*. NUREG–2105, Volumes 1 and 2, Washington, D.C. Accession Nos. ML12307A172, ML12307A176.

NRC (U.S. Nuclear Regulatory Commission). 2014. *Spent Fuel Transportation Risk Assessment: Final Report*. NUREG–2125, Washington D.C. Accession No. ML14031A323.

PFS (Private Fuel Storage, LLC.). 2001. *Environmental Report, Private Fuel Storage Facility, Skull Valley Indian Reservation, Tooele County, Utah (Revision 14)*. La Crosse, Wisconsin.

PFS (Private Fuel Storage, LLC.). 2012. Letter from R.M. Palmberg to NRC dated December 20, 2012, regarding “Termination of NRC License No. SNM–25 13 for Private Fuel Storage LLC.” La Crosse, Wisconsin. Accession No. ML12356A063.

Sprung, J.L., D.J. Ammerman, N.L. Breivik, R.J. Dukart, F.L. Kanipe, J.A. Koski, G.S. Mills, K.S. Neuhauser, H.D. Radloff, R.F. Weiner, and H.R. Yoshimura. 2000. *Reexamination of Spent Fuel Shipment Risk Estimates*. NUREG/CR–6672, Sandia National Laboratory, Albuquerque, New Mexico. Accession No. ML003698324.

6.0 Cumulative Impacts

The Council on Environmental Quality's (CEQ's) regulations implementing the National Environmental Policy Act of 1969, as amended (NEPA), define a cumulative impact as "... the impact on the environment that results from the incremental impact of [an] action when added to other past, present, and reasonably foreseeable future actions, regardless of what agency (Federal or non-Federal) or person undertakes such other actions" (Title 40 of the *Code of Federal Regulations* 1508.7 [40 CFR 1508.7]). Cumulative impacts can result from individually minor, but collectively significant, actions taking place over a period of time. It is possible that an impact that may be SMALL by itself could result in a MODERATE or LARGE cumulative impact when considered in combination with the impacts of other actions on the affected resource. For example, if a resource is regionally declining or imperiled, even a SMALL individual impact could be substantial if it contributes to or accelerates the overall resource decline.

6.1 Methodology for Assessing Cumulative Impacts

The cumulative impacts assessment in this *Generic Environmental Impact Statement for Continued Storage of Spent Nuclear Fuel* (GEIS) examines the incremental impact of continued storage on each resource area in combination with other past, present, and reasonably foreseeable actions. The general approach for assessing cumulative impacts is based on principles and guidance described in the CEQ's *Considering Cumulative Effects under the National Environmental Policy Act* (CEQ 1997). In addition, the U.S. Nuclear Regulatory Commission (NRC) reviewed the relevant portions of the U.S. Environmental Protection Agency's (EPA's) *Consideration of Cumulative Impacts in EPA Review of NEPA Documents* (EPA 1999) and *The NEPA Task Force Report to the Council on Environmental Quality on Modernizing NEPA Implementation* (CEQ 2003). Based on the review of these documents, and NRC's regulations implementing NEPA in 10 CFR Part 51, the NRC developed the following methodology for assessing cumulative impacts in this GEIS:

1. During the scoping and consultation phases of the environmental review, the NRC identified potential cumulative impact issues associated with the continued storage of spent nuclear fuel (spent fuel). The NRC included other actions and issues later as they were identified.
2. The individual resources, ecosystems, and human communities identified in the affected environment sections of Chapter 3 become the resource parameters analyzed in this analysis. Similarly, direct and indirect impacts identified in Chapters 4 and 5 form the basis for the analysis in this chapter.
3. The spatial boundaries for the cumulative impact assessment are unique to each resource area and defined in resource-specific analyses in Section 6.4. Each geographic area of

Cumulative Impacts

analysis includes the area surrounding a continued storage site and extends to where the resource would be affected by continued storage and could have overlapping impacts with other past, present, and reasonably foreseeable future actions.

4. The temporal boundary (i.e., the timeframe) for this analysis is defined in Section 6.2. The timeframe of the cumulative impacts analysis extends from the past history of impacts on each resource through decommissioning of the spent fuel pool, at-reactor independent spent fuel storage installation (ISFSI), and away-from-reactor ISFSI (referred to as storage facilities). The temporal boundary is the same for all resource-specific analyses below (Section 6.4).
5. The NRC evaluated cumulative impacts by considering the incremental impacts from continued storage in combination with other past, present, and reasonably foreseeable future actions. The description of the affected environment in Chapter 3 for at-reactor storage facilities and Chapter 5 for away-from-reactor ISFSIs serves as the *baseline* for the cumulative impacts analysis, including the effects of past actions. The *incremental impacts* related to continued storage are described and characterized in Chapter 4 for at-reactor storage facilities and Chapter 5 for away-from-reactor storage facilities. The NRC identified *past, present, and reasonably foreseeable future actions*. These actions include projects and activities that could impact resources, ecosystems, or human communities within the defined spatial and temporal bounds. Section 6.3.1 describes the general national, regional, and local trends and activities (general trends) that occur near at-reactor and away-from-reactor storage facilities, such as urbanization or energy production. These general trends are the current and likely future trends in general types of activities that occur near storage facilities. Section 6.3.2 describes other NRC-regulated or spent fuel-related activities that may occur during the period of continued storage, such as decommissioning of the nuclear power plant.
6. Cumulative impacts for each resource area are assessed in Section 6.4. Overlapping or cumulative impacts could occur if the action or general trend affects the same resource, ecosystem, or human community as those affected by the continued storage of spent fuel within the defined temporal and spatial bounds. Because of the various resource parameters (e.g., an ecosystem versus a human community) and the different spatial boundaries (e.g., a river versus a county) for each resource area, some activities or general trends affect a subset of the resource areas discussed below. The level of detail describing the various cumulative impacts is commensurate with the impact significance.
7. Conclusions for resource and systems analyses in these sections use the same three-level classification scheme—SMALL, MODERATE, or LARGE—that was used for the at-reactor and away-from-reactor storage facility analyses, as defined in Chapter 1. For resource areas in which the cumulative impact could range based on the site-specific conditions, the below analyses describe the general conditions for which a SMALL, MODERATE, or

LARGE impact would occur. A conclusion is provided for at-reactor and away-from-reactor sites and for all three timeframes (short-term, long-term, and indefinite storage) discussed in Chapters 4 and 5.

8. The analysis in this chapter, as in the rest of this GEIS, provides a generic analysis that will ultimately be used to support NRC's decision regarding a request to license or relicense a reactor or site-specific ISFSI. A site-specific review is required before the NRC provides a license for any reactor or ISFSI for which an application for a specific license has been submitted. Therefore, the analysis in this chapter would be considered along with the site-specific analysis for a specific license.

6.2 Spatial and Temporal Bounds of the Cumulative Impacts Assessment

The spatial boundaries for the cumulative impact assessment are resource-specific and identified within each resource-specific analysis below in Section 6.4. The NRC set the spatial boundaries to encompass the geographic area of the affected resources and the distances at which impacts associated with past, present, and reasonably foreseeable actions may occur.

In addition to impacts accumulating over a geographic area, impacts can also accumulate or develop over time. Therefore, the cumulative impacts assessment looks across a specific timeline that includes the past, present, and reasonably foreseeable future (CEQ 1997). The temporal boundary for this analysis includes activities that could occur through decommissioning of at-reactor or away-from-reactor storage facilities.

The spatial and temporal boundaries describe the maximum distance or time considered in the analysis. However, even if a project falls within these overall temporal and spatial bounds, the effects may not overlap in space and time with the effects of continued storage, especially for projects with short-term impacts. For example, constructing a small dock along a shoreline would have temporary impacts on aquatic resources. Unless the dock was constructed during the period of continued storage, the impacts would not likely overlap with potential impacts from continued storage. On the other hand, construction and operation of a dam could have long-term impacts that last several decades. Therefore, the impacts could be overlapping with continued storage, even if dam operations ceased several years before continued storage. Resource-specific analyses in Section 6.4 only describe activities that would overlap in both space and time with potential impacts from continued storage.

6.3 Past, Present, and Reasonably Foreseeable Actions

This section describes the NRC's methodology for identifying past, present, and reasonably foreseeable actions. As described in CEQ guidance (CEQ 1997), identifying reasonably

Cumulative Impacts

foreseeable future actions is a critical component of a cumulative impacts analysis. However, the CEQ also recognizes that agencies should not engage in speculation in an effort to identify all actions that could contribute to overall potential cumulative effects. Given the national scope of the U.S. nuclear industry and the long timeframes that are under consideration in this GEIS as described in Chapter 1, it is not practical to consider all potential public and private projects. For this reason, reasonably foreseeable future actions that will be considered in the cumulative effects analysis include the following:

- general trends or activities that the NRC has previously determined to occur near at-reactor and away-from-reactor storage facilities,
- programmatic actions for which Federal agencies have prepared and published NEPA documents,
- programs and policies enabled by legislation, and
- NRC activities or connected actions that could occur at or beyond the storage site during continued storage.

The following sections summarize the past, present, and reasonably foreseeable actions considered in this cumulative analysis, including both general trends in Section 6.3.1 and other NRC-regulated or spent fuel-related activities in Section 6.3.2.

6.3.1 General Trends and Activities

Because of the uncertainty of specific activities that may occur over very long time periods in the future, the NRC considered the general types of activities that occur near at-reactor and away-from-reactor storage facilities and the likely future trends of these activities. This approach follows CEQ (1997) guidance that recommends looking at the trends of various actions to analyze the potential activities that could occur through the reasonably foreseeable future, especially in situations with high uncertainty. The NRC notes that the uncertainty related to the extent and intensity of reasonably foreseeable activities generally increases with time into the future.

To determine typical activities that occur near at-reactor and away-from-reactor storage facilities, the NRC reviewed the cumulative impacts evaluations in NUREG-1437, *Generic Environmental Impact Statement for License Renewal of Nuclear Plants, Revision 1* (License Renewal GEIS) (NRC 2013a), site-specific EISs for new and operating reactors (e.g., NRC 2011a-e, 2012a, 2013b,c), and site-specific at-reactor and away-from-reactor ISFSI environmental assessments (EAs) or environmental impact statements (EISs) (e.g., NRC 2001a). The NRC also reviewed licensing documents for power reactors because at-reactor storage facilities are located at the reactor site, and therefore, at-reactor storage facilities are surrounded by the same activities as those identified in site-specific EISs for new reactors,

supplemental EISs for license renewal of operating reactors, and in the License Renewal GEIS for operating reactors. Table 6-1 describes the types of activities that the NRC identified.

The NRC also evaluated the reasonably foreseeable trend for each activity, primarily using projections prepared by Federal, State, and local agencies. In some cases, the NRC considered projections estimated by industry-based policy organizations, especially for activities with limited Federal, State, and local oversight. Trends in activities, facilities, or processes are based on projections as far into the future as reasonably foreseeable for the particular industry or activity. For many activities, the available projections cover shorter time periods, on the order of 25 to 40 years. The NRC qualitatively used these projections to estimate reasonable trends during continued storage. While the NRC considers this a reasonable approach based on the best available data, the NRC also notes that applying the trends beyond the time period specified for each activity introduces additional uncertainty. In addition, the NRC assumed that local, State, and Federal authorities would continue to have oversight over the construction and operation of many of the activities described in Table 6-1.

Table 6-1. General Trends and Human Activities Occurring at or near Storage Facilities

Activity or Stressor	Reasonably Foreseeable Future Trend
<i>Increased Energy Demand</i>	
Overall energy demand	Total energy use will increase by 10% from 2011 to 2040 (EIA 2012a). For at-reactor storage facilities, shutdown of the reactor will likely require replacement power, which may be built at the reactor site depending on spatial and water-use requirements, power needs, and the business plans of the operator (NRC 2013a).
Overall electricity consumption	Increased electricity consumption at an average annual rate of 0.9% (EIA 2012a).
New and continued construction and operation of gas-fired plants	About 0.8% annual increase from 2011 to 2040 (EIA 2012a).
New and continued construction and operation of coal-fired plants	About 0.1% annual increase from 2011 to 2040 (EIA 2012a).
New and continued construction and operation of nuclear plants	About 0.5% annual increase from 2011 to 2040 (EIA 2012a).
Continued operation of oil-fired plants	About 0.9% annual increase from 2011 to 2040 (EIA 2012a).
New and continued construction and operation of wind farms	About 2.8% annual increase from 2010 to 2035 (EIA 2012b).
New and continued construction and operation of conventional hydropower plants	About 0.8% annual increase from 2010 to 2035 (EIA 2012b).
New and continued construction and operation of solar plants	About 5.1% to 16.4% annual increase from 2010 to 2035 (EIA 2012b).

Cumulative Impacts

Table 6-1. General Trends and Human Activities Occurring at or near Storage Facilities
(cont'd)

Activity or Stressor	Reasonably Foreseeable Future Trend
Construction and operation of transmission lines	About 29,000 additional circuit miles of high-voltage transmission capacity from 2011 to 2017 (EIA 2011).
New and continued construction and operation of pipelines	About 13,000 additional miles of natural gas pipelines and 19,000 additional miles of oil pipeline infrastructure through 2035 (INGAA 2011).
New and continued construction and operation of petroleum and liquefied natural gas facilities and terminals	Domestic production of liquefied natural gas is projected to increase from about 1.7% of the natural gas supply in 2010 to about 2.5% in 2035 (INGAA 2011; NPC 2011).
New and continued operation of oil refineries	Increase in oil refinery capacity from about 1.3 to 4.3 million barrels of oil per day from 2010 to 2030, depending on economic growth and price assumptions (EIA 2012c). Additional capacity will most likely be from expansions, updates, and modifications to existing refinery fleet, rather than construction of new facilities (NPC 2007).
New and continued oil and gas exploration and extraction activities	Domestic production of crude oil increases, mostly due to onshore production of shales and tight formations. Natural gas is expected to increase from 24% to 30% of electric power generation from 2011 to 2040 (EIA 2012a).
New and continued uranium ore exploration and extraction activities	New and continued uranium ore exploration and extraction activities expected based on the 0.5% annual increase from 2011 to 2040 for nuclear power generation.
<i>Continued Use of Radiological Materials</i>	
Construction and operation of new and existing at-reactor ISFSIs	Increase in total commercial spent fuel by about 2000 to 2400 MT/yr (NRC 2013d). About 9,500 dry storage systems would be loaded by 2050, with an additional 1,000 systems (10,500 total) loaded by 2075 (BRC 2012).
New and continued activities at hospitals and industrial facilities that produce and use radioactive materials, such as medical or industrial isotopes	Increase likely given the prevalence of nuclear medicine in current treatment technologies (112 million nuclear medicine/radiation therapy procedures annually [NRC 2000]), current demand (e.g., 78 FR 19537), and increasing population and aging demographics.
Continued operation of research and test reactors	As of June 2013, 31 NRC-licensed research reactors operate in the United States of which 17 have been granted a renewed license and 14 are currently under review for license renewal (NRC 2013e). Similar levels are expected in future.
Continued operation of fuel fabrication facilities	Slight decrease based on an estimate of 15.4 million separative work units in 2015 to 14.2 million separative work units in 2025 (EIA 2012d).

Table 6-1. General Trends and Human Activities Occurring at or near Storage Facilities
(cont'd)

Activity or Stressor	Reasonably Foreseeable Future Trend
<i>Increased Water Demand</i>	
Continued transfer of water within and across water basins	Increase likely to establish reliable water supplies to support population growth (e.g., Texas Water Development Board 2012).
New and continued operation of drinking water-treatment plants and water-supply facilities	Total withdrawals of water for consumption to increase by about 50% from 2010 to 2040 (USACE 2006).
<i>Population Growth and Demographic Shifts</i>	
Overall Population Growth (in the U.S.)	Total U.S. population expected to increase from 321 million (2015) to 420 million (2060) (USCB 2012).
<i>Increased Urbanization</i>	
River, shoreline, canal, or channel modifications including dredging and erosion-prevention programs	Activities expected to continue based on statutory authority for U.S. Army Corps of Engineers (USACE), population growth, and urbanization.
Construction of housing units	An increase in total housing units is expected from 105.2 million units in 2010, to 143 to 153 million units in 2030, to 153 to 192 million units in 2050 (Pitkin and Myers 2008).
Construction of commercial buildings	Similar to housing construction, commercial construction would be expected to increase with population growth and continued urbanization.
Waterfront development	Coastal populations likely to increase, particularly in warmer coastal regions in the south based on population growth and housing trends.
<i>Transportation</i>	
Construction of transportation infrastructure (e.g., roads, bridges, and rail)	Additional infrastructure likely based on population growth. In addition, increased reliance on mass transit would reduce the need for new long-distance highway infrastructure (National Research Council 2009).
<i>Other Activities and Stressors</i>	
Continued agricultural activities, aquaculture activities, and commercial fishing	Agricultural and aquaculture production and commercial fishing would likely increase to provide food for an increasing national population (USDA 2012).
Continued industrial and manufacturing activities	Industrial and manufacturing activities (e.g., mines, quarries, glass manufacturing, chemical facilities—including organic chemical, inorganic chemical, and other miscellaneous chemical product and preparation manufacturing) would be anticipated to increase to provide goods and services for an increasing national population.

Cumulative Impacts

Table 6-1. General Trends and Human Activities Occurring at or near Storage Facilities
(cont'd)

Activity or Stressor	Reasonably Foreseeable Future Trend
Continued resource management at State and Federal parks, preserves, wildlife management areas, national wildlife refuges, and recreational areas, or other private or public efforts to restore, preserve, or enhance natural communities	Government land management agencies will continue to operate and manage Federal and State properties in accordance with their statutory authority. Legislation in Congress or in State legislatures may revise (either expand or reduce) agency authority (e.g., NPSCC 2009).
Continued operation and closure of various military facilities	Military facilities will continue to support combat readiness and national security, but projections indicate that future overall military budgets will be reduced, accompanied by a reduction in active-duty strength (78 FR 21919).
Climate change	Increased temperature, sea-level rise, and changes in precipitation levels as described in the U.S. Global Climate Research Project (GCRP) (2014). Depending on the assumed scenario, global temperatures in 2100 are predicted to increase by 1.7°C (most aggressive carbon emissions control) to 5.5°C (least aggressive carbon emissions control). Sea level is predicted to increase 0.305 to 1.22 m by 2100. Reduced snowpack in western mountains is predicted (USACE 2006).

6.3.2 Other NRC-Regulated or Spent Fuel-Related Activities during Continued Storage

In addition to the incremental impacts from continued storage described in Chapters 4 and 5, other NRC-regulated or spent fuel-related activities could affect the same resources as those affected by continued storage. These activities include other NRC-regulated actions that would occur at the storage site or connected actions that could occur at or beyond the storage site. A summary of these activities considered in this cumulative analysis is provided below. Note that some of the activities apply only to a subset of the timeframes described in Chapters 4 and 5. For example, dry transfer system (DTS) construction and decommissioning would occur only during long-term storage or indefinite storage, but would not occur during short-term storage.

6.3.2.1 Final Reactor Shutdown Activities Prior to Decommissioning

These activities could involve an initial increase in staff to execute shutdown: a decrease and ultimately, a cessation of reactor power output to grid; an increase in power demand to support onsite activities; a decrease in demand for power plant operational cooling; and the potential for removal of some structures and equipment.

Also see the description of shutdown activities in Section 2.2.

6.3.2.2 Decommissioning of the Reactor Power Block (including the spent fuel pool), DTS, and ISFSI

Decommissioning includes activities to remove radioactive materials from structures, systems, and components to demonstrate compliance with NRC release limits in 10 CFR Part 20, Subpart E. Reactor decommissioning of facilities not related to spent fuel storage could occur from the time that the licensee certifies that it has permanently ceased power operations until the license is terminated. To facilitate decommissioning at some sites, the operator may construct a new spent fuel pool cooling system to allow the spent fuel pool to be isolated from other reactor plant systems.

Decommissioning of the spent fuel pool could begin after stored spent fuel has been transferred to dry storage. The NRC generically evaluated the environmental impacts from reactor decommissioning including the spent fuel pool (but not ISFSIs) in NUREG-0586, *Final Generic Environmental Impact Statement on Decommissioning of Nuclear Facilities, Supplement 1* (Decommissioning GEIS) (NRC 2002). The NRC previously evaluated the environmental impacts of decommissioning an away-from-reactor ISFSI in NUREG-1714, *Final Environmental Impact Statement for the Construction and Operation of an Independent Spent Fuel Storage Installation on the Reservation of the Skull Valley Band of Goshute Indians and the Related Transportation Facility in Tooele County, Utah* (PFSF EIS) (NRC 2001a) and in site-specific at-reactor ISFSIs in the Calvert Cliffs, Humboldt Bay, H.B. Robinson, Surry, Oconee, and Diablo Canyon EAs (NRC 2003, 2005a-c, 2009, 2012b). Decommissioning of the DTS is only applicable for long-term and indefinite storage. Also see the description of decommissioning activities in Section 2.2.

6.3.2.3 Activities to Prepare the Spent Fuel for Transportation to a Repository for Final Disposal

These activities would include transferring spent fuel that was stored in dual-purpose canisters from the storage casks to transportation packages and then loading the transportation packages on conveyances before transportation to a repository. Spent fuel stored in storage-only casks or that would otherwise require bare fuel handling (as described in Chapter 2) would be transferred to transportation-certified packages using the spent fuel pool for short-term storage and the DTS long-term storage timeframe. These transportation-related activities could begin when a repository begins accepting shipments of spent fuel from power reactors. This activity would only occur for short-term and long-term storage, because indefinite storage assumes that a repository is never built.

Cumulative Impacts

6.3.2.4 Transportation of Spent Fuel from an At-Reactor or Away-From-Reactor Storage Facility to a Repository for Disposal

As described in Section 1.1, the Federal government has adopted deep geologic disposal as the national solution for spent fuel disposal (Nuclear Waste Policy Act of 1982) and the U.S. Department of Energy (DOE) has reaffirmed the Federal government's commitment to the ultimate disposal of spent fuel (DOE 2013). When a repository is available to accept shipments of spent fuel, facility operators would ship spent fuel in NRC-approved transportation packages from facility locations across the United States to a repository site. Shipments would be required to comply with applicable NRC and U.S. Department of Transportation regulations for the transportation of radioactive materials in 10 CFR Part 71 and 49 CFR Parts 171 through 180. Transportation of spent fuel to a repository would only occur during short-term and long-term storage because indefinite storage assumes a repository is never built.

6.4 Resource-Specific Analyses

6.4.1 Land Use

This section evaluates the effects of continued storage on land use when added to the aggregate effects of other past, present, and reasonably foreseeable future actions. As described in Sections 4.1 and 5.1, the incremental impacts from continued storage on land use would be SMALL for all timeframes at both at-reactor and away-from-reactor storage facilities.

The geographic area considered in the cumulative land use analysis includes all affected land surrounding the at-reactor and away-from-reactor storage facilities. Residential, commercial, industrial, agricultural, forested, and recreational lands typically surround spent fuel storage facilities. Depending on the site, the land surrounding a spent fuel storage facility could include private and public lands in a range of political jurisdictions including towns, townships, service districts, counties, and parishes. In addition, State, Federal, and Native American lands are present within the area considered for this analysis.

6.4.1.1 Potential Cumulative Impacts from General Trends and Activities

Cumulative impacts on land use include (1) changing and disturbing existing land-use conditions, (2) restricting access or establishing right-of-way access, (3) restricting agricultural or recreational activities, and (4) altering ecological or historic and cultural resources (e.g., NRC 2011a–e, 2012a, 2013a–c). Cumulative impacts could occur from the activities described in Section 6.3.1, such as constructing and operating new and existing energy projects and infrastructure (e.g., replacement power), water development projects, and constructing housing units, commercial buildings, roads, bridges, and rail lines (e.g., NRC 2011a–e, 2012a,

2013a–c). In addition, climate change can affect agricultural and ranching land uses because of changes in crop yields and livestock productivity (GCRP 2014). Climate change can also lead to higher sea levels (GCRP 2014), thereby changing land use through inundation and loss of coastal wetlands and other low-lying areas.

The magnitude of cumulative land-use impacts resulting from general trends taking place near a storage facility would depend on current land-use patterns and proposed land-use changes, the number (and density) of actions, and the extent to which these actions (facilities or projects) employ mitigation measures to reduce impacts. The cumulative impacts from general trends and activities would range from minimal (e.g., minor changes in land use from limited development in the area, see NRC 2011d) to noticeable (e.g., construction and operation of a new coal-fired power plant, new transmission lines, and climate change in the area, see NRC 2011a). Growth control measures, such as zoning restrictions and implementation of local land use or master plans, are expected to limit development near a storage facility. Therefore, the cumulative impacts are not expected to be destabilizing (e.g., major changes in land use from uncontrolled development in the area).

6.4.1.2 Potential Cumulative Impacts from Other NRC-Regulated or Spent Fuel-Related Activities

Cumulative impacts on land-use conditions could result from other NRC-regulated or spent fuel-related activities, such as decommissioning of the reactor power block (including the spent fuel pool), ISFSIs, and DTS.

Activities associated with decommissioning of the reactor power block (including the spent fuel pool) that could impact land use include (1) addition and expansion of staging and laydown areas for equipment, (2) construction of temporary buildings and parking areas, (3) removal of large reactor components, (4) structure dismantlement, and (5) low-level waste (LLW) storage and packaging (NRC 2002). To facilitate decommissioning at some sites, the operator may construct a new spent fuel pool cooling system to allow the spent fuel pool to be isolated from other reactor plant systems in order. In the Decommissioning GEIS for power reactors, the NRC (2002) determined that changes to land use from these activities would be temporary and would not be detectable. Most reactor sites have sufficient area for these activities within the previously disturbed area (whether during construction or operation of the site); therefore, no additional land disturbance would be anticipated. The impacts from decommissioning spent fuel pools were considered in the Decommissioning GEIS. Given that the impacts from decommissioning reactors and spent fuel pools would be similar to that described in the Decommissioning GEIS for reactors, impacts on onsite land use during decommissioning are expected to be minimal.

Activities associated with decommissioning ISFSIs that could impact land use include (1) decontaminating the concrete storage casks; (2) dismantling and removing the concrete

Cumulative Impacts

storage casks, concrete pads, and support facilities, including the DTS; and (3) removing any contaminated soil identified during the final radiological site survey. In most cases, land disturbance impacts associated with decommissioning ISFSIs would be similar to or less than land disturbance impacts associated with constructing ISFSIs (NRC 2003, 2005a–c, 2009, 2012b). After decommissioning activities are complete, the area previously occupied by the at-reactor or away-from-reactor ISFSI would typically be covered with topsoil, contoured, and replanted with native vegetation (NRC 2005c). The goal of decommissioning is to release the site for unrestricted use. Because the land disturbance impacts from decommissioning at-reactor and away-from-reactor ISFSIs would be similar to or less than those associated with constructing ISFSIs, impacts on land use during decommissioning are expected to be minimal.

6.4.1.3 Conclusion

Cumulative impacts on land use include the incremental effects from continued storage when added to the aggregate effects of other past, present, and reasonably foreseeable future actions. As described in Sections 4.1 and 5.1, the incremental impacts from continued storage on land use is SMALL for all timeframes at both at-reactor and away-from-reactor storage facilities. In addition, past, present, and reasonably foreseeable activities take place in the geographic area of interest that could contribute to cumulative effects on land use. The cumulative impacts on land use from continued storage when added to other past, present, and reasonably foreseeable Federal and non-Federal activities are SMALL to MODERATE depending on land-use patterns and activities surrounding the site. A SMALL impact would occur if no other actions occur that have overlapping, noticeable effects on land use. A MODERATE impact would occur if NRC or other Federal or non-Federal actions, such as construction and operation of other nearby nuclear, coal-fired, or gas-fired power plants or future urbanization, have overlapping impacts with the continued storage of waste that noticeably altered land use. At storage facilities where the cumulative impacts would be MODERATE from other Federal or non-Federal activities, the NRC determined the cumulative impacts would likely remain MODERATE whether or not continued storage occurred because the incremental impacts from continued storage would be minor, especially in comparison to other general trends, such as urbanization.

6.4.2 Socioeconomics

This section evaluates the socioeconomic effects of continued storage when added to the aggregate effects of other past, present, and reasonably foreseeable future actions. As described in Sections 4.2 and 5.2, the adverse effects of continued storage are SMALL for all at-reactor and away-from-reactor spent fuel storage facilities because of the small number of workers required to maintain and monitor the storage of spent fuel. In addition, construction and operation of an away-from-reactor storage facility could generate potentially LARGE beneficial economic impacts in some rural communities as well as SMALL adverse socioeconomic impacts due to increased demand for housing and public services.

The geographic area considered in the cumulative socioeconomic resources analysis is the socioeconomic region of influence, which includes the areas where spent fuel storage workers and their families reside, spend their income, and use their benefits. Thus, in these areas, storage facility workers both directly and indirectly affect the economic conditions of the region.

6.4.2.1 Potential Cumulative Impacts from General Trends and Activities

Cumulative socioeconomic impacts in local communities could affect (1) employment and income, (2) tax revenues, (3) population and housing demand, and (4) the availability and demand for public services (NRC 2008, 2011d, 2012a, 2013a). New energy projects (e.g., replacement power); industrial, commercial, and agricultural development; and regional tourism and recreation, could cause an increase in population, demand for housing and services, traffic volume, and tax revenue paid to local jurisdictions. In addition, an at-reactor ISFSI located at or near an operating reactor would experience cumulative impacts associated with reactor operations, such as traffic and tax revenue.

The magnitude of the socioeconomic impact resulting from general trends within close proximity of a spent fuel storage facility would depend on the intensity of development. Cumulative impacts would be specific to the region in which the storage facility is located and would range from minimal (e.g., minor increase in demand for public services caused by construction and operation of a new industry or power plant, see NRC 2011d) to noticeable (e.g., noticeable increase in housing and rental prices because of increased demand caused by the construction and operation of a new industry or power plant, see NRC 2008). In most situations, the cumulative impacts could be both adverse and beneficial (e.g., increased traffic, demand for public services, and increased property tax revenue, see NRC 2012a).

6.4.2.2 Potential Cumulative Impacts from Other NRC-Regulated or Spent Fuel-Related Activities

Cumulative impacts could result from other NRC-regulated or spent fuel-related activities, such as decommissioning the power block (including the spent fuel pool), ISFSI, and DTS. The extent to which impacts would be cumulative would depend on the timing of decommissioning in relation to other activities (e.g., termination of reactor operations and power plant shutdown).

The immediate socioeconomic impact caused by terminating reactor operations and power plant shutdown would be greater than the impact from decommissioning the power block. The socioeconomic impacts from terminating reactor operations and power plant shutdown are described in both the Decommissioning GEIS (NRC 2002) and the License Renewal GEIS (NRC 2013a), as described below.

As discussed in Section 3.2, the size of the nuclear power plant operations workforce varies considerably among operating U.S. nuclear power facilities and ranges from 600 to

Cumulative Impacts

2,400 workers. Operating nuclear power plants generally provide a significant amount of tax revenue to local communities and public school districts. Impacts associated with power plant shutdown include the loss of jobs at the nuclear plant and in surrounding communities; and a corresponding reduction in tax payments, demand for housing and public services, and traffic volume. As stated in Section 3.2, property tax payments would continue as long as spent fuel is stored onsite. Publicly owned tax-exempt nuclear power plants, fully depreciated plants, or plants located in urban or an urbanizing area with a large or growing tax base would not experience many changes in overall socioeconomic conditions (NRC 2002). In rare circumstances in which a large nuclear power plant located in a rural area permanently ceases operations early and delays decommissioning, the affected area could experience greater impacts (NRC 2002). Impacts from the loss or reduction of tax revenue because of the termination of reactor operations and power plant shutdown on community services could range from SMALL to LARGE (NRC 2013a). Considering all variables, such as plant size and community size as equivalent, plants that begin decommissioning immediately would have less immediate negative impacts because the workforce reduction would occur gradually (NRC 2002).

Impacts associated with decommissioning a power block (including the spent fuel pool) are described in the Decommissioning GEIS (NRC 2002). While there would be an overall reduction in the number of workers at the nuclear plant during decommissioning, the size of the workforce would have already been substantially reduced after the termination of reactor operations and power plant shutdown. The Decommissioning GEIS estimated that between 100 and 200 workers would be needed to support decommissioning (NRC 2002). The socioeconomic impact from decommissioning the power block and spent fuel pool would depend on the size and location of the facility and would eventually result in the loss of jobs upon completion, including reduced housing demand, tax revenues, and demand for public services. However, the NRC concluded that the overall socioeconomic impact from decommissioning the power block would be SMALL due to the gradual reduction in the workforce and purchasing activities at the power plant site (NRC 2002).

Because of the smaller workforce involved, the socioeconomic impact from decommissioning any ISFSI and associated DTS would be less than experienced from the decommissioning the power block. Decommissioning activities would commence after spent fuel has been transported offsite to either a repository or an away-from-reactor storage facility. Funding plans for decommissioning ISFSIs (MYAPC 2013; CYAPC 2012; YAEC 2012) estimate that approximately 50 workers would be needed to decommission the storage facility over a 1- to 1.5-year period. Decommissioning the DTS could occur in parallel with decommissioning the ISFSI and would represent a minor increase to the workforce. Based on DOE's Topical Safety Analysis Report (DOE 1996), it was estimated that a 5-person workforce could decommission the DTS within 60 days. Workforce numbers and duration of decommissioning activities would vary from site to site. A review of NRC EAs and EISs for construction, operation, and renewal

of site specifically licensed at-reactor and away-from-reactor ISFSIs (NRC 2001a, 2003, 2005a–c, 2009, 2012b) did not identify any significant socioeconomic impacts during decommissioning of ISFSIs. The magnitude of impacts from decommissioning an ISFSI at other sites would be similar to that described in the Calvert Cliffs, Humboldt Bay, H.B. Robinson, Surry, Oconee, and Diablo Canyon EAs and the PFSF EIS because of considerations of workforce, housing demand, traffic networks, and public services. Because the impacts from decommissioning at-reactor and away-from reactor ISFSIs would be similar to that described in site-specific ISFSI EAs and the PFSF EIS, socioeconomic impacts during decommissioning are expected to be minimal.

6.4.2.3 Conclusion

Cumulative impacts include the incremental effects from continued storage when added to the aggregate effects of other past, present, and reasonably foreseeable future actions. As described in Sections 4.2 and 5.2, the adverse effects of continued storage are SMALL for at-reactor and away-from-reactor storage facilities because of the small number of workers required to maintain and monitor the storage of spent fuel. However, construction and operation of an away-from-reactor storage facility could generate potentially LARGE beneficial economic impacts in some rural economies as well as SMALL adverse socioeconomic impacts due to increased demand for housing and public services. In addition, other past, present, and reasonably foreseeable activities could also contribute to cumulative socioeconomic impacts. The cumulative socioeconomic impacts from continued storage when added to other past, present, and reasonably foreseeable Federal and non-Federal activities, such as the termination of reactor operations, decommissioning, construction of replacement power projects, urbanization, and transportation projects, are SMALL to LARGE depending on the activity and location of the action relative to the storage facility. A SMALL impact would occur if there are no other actions that have overlapping, noticeable socioeconomic effects. A MODERATE impact would occur if other Federal or non-Federal actions, such as construction and operation of a new power plant, have overlapping impacts with continued storage that would noticeably alter socioeconomic conditions (e.g., increased traffic and tax revenues). LARGE impacts are unlikely because local planning and zoning authorities would ensure that new projects do not destabilize socioeconomic conditions. At storage facilities for which the adverse cumulative impacts would range from MODERATE to LARGE because of other Federal and non-Federal activities, the adverse cumulative impacts would be MODERATE to LARGE regardless of continued storage because the incremental operational effects from continued storage would be minor when compared to other activities and economic trends, such as urbanization or construction and operation of new industries and power plants.

6.4.3 Environmental Justice

This section describes the impacts on minority and low-income populations resulting from continued storage when added to the aggregate effects of other past, present, and reasonably

Cumulative Impacts

foreseeable future actions. As described in Sections 4.3 and 5.3, minority and low-income populations are not expected to experience disproportionately high and adverse human health and environmental effects from the incremental impacts associated with continued storage.

The environmental justice cumulative impact analysis assesses the potential for minority and low-income populations to experience disproportionately high and adverse human health and environmental effects from the continued storage of spent fuel combined with past, present, and reasonably foreseeable future actions. Adverse health effects are measured in terms of the risk and rate of fatal or nonfatal adverse impacts on human health. An adverse environmental impact is an impact that is determined to be both harmful and significant (as employed by NEPA).

Disproportionately high and adverse human health effects occur when the risk or rate of exposure to an environmental hazard for a minority or low-income population is significant and exceeds the risk or exposure rate for the general population or for another appropriate comparison group. Disproportionately high environmental effects refer to impacts, or risk of impacts, on the natural or physical environment in a minority or low-income community that are significant and appreciably exceed the environmental impact on the larger community. Such effects may include biological, cultural, economic, or social impacts (NRC 2013a).

Additionally, the cumulative impact assessment considers the potential radiological risk to minority and low-income population groups residing within the 80 km (50 mi) region from the spent fuel storage facility as well as the potential exposure from other sources of radiation from other actions. As stated in Section 3.3, special population groups include populations that rely principally on fish or wildlife for subsistence.

6.4.3.1 Potential Cumulative Impacts from General Trends and Activities

Potentially adverse human health and environmental effects from activities associated with industrial, commercial, agricultural, and transportation developments can affect the resources on which minority and low-income populations depend (e.g., fish, game animals, and native vegetation) (NRC 2013a). For example, potential impacts on minority and low-income populations from the construction and operation of replacement power and other industrial projects in the vicinity of storage facilities would mostly consist of environmental (e.g., noise, dust, and traffic) and socioeconomic (e.g., employment and housing) effects during construction. Noise and dust impacts during construction would be of short duration and primarily limited to onsite activities. Minority and low-income populations residing along site access roads could be directly affected by increased commuter vehicle and truck traffic. However, these effects could be limited to certain hours of the day. Increased demand for rental housing during construction could cause rental costs to temporarily rise, disproportionately affecting low-income populations living near the site that rely on inexpensive housing. However, given the proximity of most industrial sites to urban areas, many workers could commute to the construction site, thereby reducing the need for rental housing.

The magnitude of human health and environmental effects resulting from all actions associated with general trends on minority and low-income populations living within close proximity of a spent fuel storage facility would depend on the intensity of the effects. Some of these potential effects have been identified in resource areas presented in Chapters 4 and 5 of this GEIS. Minority and low-income populations are subsets of the general population residing in the area and all would be exposed to the same hazards generated from activities associated with continued storage.

6.4.3.2 Potential Cumulative Impacts from Other NRC-Regulated or Spent Fuel-Related Activities

Cumulative impacts could result from other NRC-regulated or spent fuel-related activities, such as terminating reactor operations, shutting down the power plant, decommissioning the reactor power block (including the spent fuel pool) and ISFSIs, and constructing and operating the DTS. The NRC also considers the potential for minority and low-income populations to experience disproportionately high and adverse human health effects and (1) whether the health effects would be significant, at or above generally accepted norms; (2) whether the risk or rate of environmental hazard exposure would be significant, exceed, or likely exceed the risk or rate to an appropriate comparison group (e.g., the general population); and (3) whether health effects would occur in a minority or low-income population already affected by cumulative or multiple adverse exposures from environmental hazards (NRC 2002).

The impacts associated with plant shutdown are described in both the Decommissioning GEIS (NRC 2002) and the License Renewal GEIS (NRC 2013a). Plant shutdown and the resulting loss of jobs, income, and tax revenue could have a disproportionate effect on minority and low-income populations (NRC 2013a). The loss of tax revenue, for example, could reduce the availability or eliminate some of the community services on which low-income and minority populations may depend (NRC 2013a).

Environmental impacts associated with decommissioning activities at a nuclear power plant site and the extent to which minority and low-income populations could be affected are discussed in the Decommissioning GEIS (NRC 2002). Decommissioning the power block and spent fuel pool would eventually result in the loss of jobs upon completion. Other impacts would include reduced housing demand, tax revenues, and the availability and demand for public services (NRC 2002). Decommissioning activities could affect air and water quality in the area around each nuclear plant site, which could cause health and other environmental impacts in minority and low-income populations that might be present in the area (NRC 2002). Population groups with particular resource dependencies or practices (e.g., subsistence agriculture, hunting, and fishing) could also be disproportionately affected (NRC 2002). In addition, the impacts associated with eventual decommissioning would be considered when a licensee submits its post-shutdown decommissioning activities report for review under 10 CFR 50.82(a)(4) or

Cumulative Impacts

10 CFR 52.110(d)(1) and its license termination plan for review and approval per 10 CFR 50.82(a)(9) or 10 CFR 52.110(i).

Because a smaller workforce would be needed, impacts from decommissioning an at-reactor ISFSI are anticipated to be less than impacts resulting from decommissioning the reactor power block. As discussed in Section 6.4.2, approximately 50 workers would be needed to decommission an at-reactor ISFSI over a 1- to 1.5-year period. Decommissioning of the DTS could occur in parallel and would represent a minor increase to the workforce. Workforce numbers and duration of decommissioning activities would vary from site to site. For away-from-reactor ISFSIs, the impacts of decommissioning would be similar to those associated with decommissioning the power block because the number of workers required to decommission both facilities are similar (NRC 2001b, 2002).

6.4.3.3 Conclusion

Cumulative impacts on minority and low-income populations include the incremental effects from continued storage when added to the aggregate effects of other past, present, and reasonably foreseeable future actions. As discussed in Section 4.3 and 5.3 of this GEIS, minority and low-income populations are not expected to experience disproportionately high and adverse effects from the incremental impacts associated with the continued storage of spent fuel. In addition, the NRC determined that disproportionately high and adverse human health effects are not expected in special pathway receptor populations in the region as a result of subsistence consumption of water, local food, fish, and wildlife. Similarly, there would be no contributory effects to human health beyond what is currently being experienced for the duration that spent fuel remains onsite. Potential effects occurring from other reasonably foreseeable offsite projects would be considered during NRC site-specific licensing reviews (e.g., construction of an away-from-reactor ISFSI, replacement of ISFSI and construction, operation, and replacement of a DTS). In addition, as indicated in the Commission's policy statement, environmental justice impacts would be considered during site-specific environmental reviews for specific NRC licensing actions (69 FR 52040).

6.4.4 Air Quality

This section evaluates the effects of continued storage on air quality resources when added to the aggregate effects of other past, present, and reasonably foreseeable future actions. As described in Sections 4.4 and 5.4, the incremental impacts from continued storage on air quality is SMALL for all timeframes at both at-reactor and away-from-reactor storage facilities, except during short-term storage at away-from-reactor ISFSIs where the impacts would range from SMALL to MODERATE because construction of a rail spur could result in noticeable impacts on air quality.

The geographic area considered in the cumulative air quality analysis includes the air quality control region in which an at-reactor or away-from-reactor storage facility is located. This area could include one or more counties that comprise the air quality control region surrounding the site, as described in Section 3.4.

6.4.4.1 Potential Cumulative Impacts from General Trends and Activities

Cumulative impacts on air quality could include degradation of air quality in air quality control regions that are already in or near nonattainment or maintenance for one or more national ambient air quality standards. For at-reactor and away-from-reactor storage facilities, cumulative impacts could occur due to multiple activities that affect the air quality control region near the storage facility (e.g., electric power generation; ground, water, and air transportation; and nearby heavy industries) associated with urbanization and industrial, commercial, agricultural, and transportation development (e.g., NRC 2011a–e, 2012a, 2013a–c). In addition, climate change can impact air quality because of higher or lower ambient air temperatures and changes in precipitation rates (GCRP 2014). For air resources near at-reactor storage facilities, additional cumulative impacts may include the following: (1) cumulative impacts due to the various impacts from an individual power plant over time (e.g., employee vehicles and emergency diesel generator testing) and (2) cumulative impacts due to closely sited power plants (e.g., air pollutant emissions from nearby coal-fired power plants) (NRC 2013a).

The magnitude of cumulative impacts resulting from all general trends within the air quality control region in which a storage facility is located would depend on the nature and location of the actions, the number (and density) of actions, and the extent to which these actions (facilities or projects) employ mitigation measures to minimize such impacts. The cumulative impacts from general trends and activities would range from minimal (e.g., minor air emissions associated with localized development in the area, see NRC 2013c) to noticeable (e.g., emissions from the construction and operation of a nearby coal-fired plant, see NRC 2011a).

6.4.4.2 Potential Cumulative Impacts from Other NRC-Regulated or Spent Fuel-Related Activities

Cumulative impacts on air quality resources could result from other NRC-regulated or spent fuel-related activities, such as (1) decommissioning of the reactor power block (including the spent fuel pool), ISFSIs, and DTS; (2) loading of packages for transportation to a repository; and (3) long-range transport of spent fuel to a repository.

Reactor power block decommissioning activities involve the use of large diesel-powered equipment for equipment removal, demolition of structures, worker transportation to and from the site, and transportation of demolition debris to waste disposal facilities. In most cases, air quality effects would be relatively minor and short term in duration. Air quality control measures, which may be required to comply with air quality permits, would also minimize air quality impacts. The Decommissioning GEIS (NRC 2002) analyzed the air quality impacts for decommissioning a

Cumulative Impacts

reactor, including the spent fuel pools. In the Decommissioning GEIS for power reactors (including spent fuel pools), the NRC determined that there would be minimal impact on air quality and concluded that the impacts of decommissioning on air quality are not detectable (NRC 2002). The NRC's EAs for the Calvert Cliffs and Diablo Canyon at-reactor ISFSIs and the PFSF away-from-reactor ISFSI EIS did not identify any significant impacts on air quality resources during decommissioning of the ISFSI (NRC 2001a, 2003, 2012a). The NRC assumes that the types and magnitude of impacts described in the Calvert Cliffs and Diablo Canyon EAs and the PFSF EIS are representative of impacts from decommissioning an at-reactor or away-from-reactor ISFSI at other sites because these facilities are typical sizes of at-reactor and away-from-reactor ISFSIs and considered typical decommissioning methods. Given that the impacts from decommissioning reactors, spent fuel pools, and ISFSIs would be similar to that described in the Decommissioning GEIS for reactors and site-specific ISFSI EAs and the PFSF EIS, impacts on air quality resources from decommissioning are expected to be minimal.

Because the same transporters, trucks, and other fossil-fuel-powered equipment are used to transfer dual-purpose canisters from transportation packages to storage casks as are used to transfer them from storage casks to transportation packages, the loading of packages for transportation to a repository would have similar air emission sources, levels, and impact magnitude as the receiving of spent fuel at an away-from-reactor facility from at-reactor locations. As described in Section 5.4.1, the NRC concluded that the operation of an away-from-reactor ISFSI, including the activity of loading casks, would be SMALL. Therefore the impact magnitude for the loading of packages for transportation to a repository would be similar.

Disposal of spent fuel requires the long-range transportation from the storage site to a repository. The at-reactor storage operation examines the impacts of a facility with a 1,600-MTU capacity whereas the away-from-reactor operation examines the impacts of a facility with a 40,000-MTU capacity. The *Final Supplemental Environmental Impact Statement for a Geologic Repository for the Disposal of Spent Nuclear Fuel and High-Level Radioactive Waste at Yucca Mountain, Nye County, Nevada* (Yucca Mountain EIS) (DOE 2008) assesses the air quality impacts for the transportation of 70,000 MTU of spent fuel within Nevada. The Yucca Mountain EIS concluded that the emissions from spent fuel transportation during operations would be distributed over the entire length of the route, and no air quality standards would be exceeded. Because the amount of spent fuel considered in the transportation analyses in this GEIS is less than the amount considered in the Yucca Mountain analyses, the NRC concludes that the transportation of spent fuel to a repository would not be greater than the impact magnitude documented in the Yucca Mountain EIS.

6.4.4.3 Conclusion

Cumulative impacts on air quality include the incremental effects from continued storage when added to the aggregate effects of other past, present, and reasonably foreseeable future actions. As described in Sections 4.4 and 5.4, the incremental impacts from continued storage

on air quality are SMALL for all timeframes for both at-reactor and away-from-reactor storage facilities, except during short-term storage at away-from-reactor ISFSIs where the impacts would range from SMALL to MODERATE. In addition, past, present, and reasonably foreseeable activities take place in the geographic area of interest that could contribute to cumulative effects to air quality resources. The cumulative impacts from continued storage when added to other past, present, and reasonably foreseeable Federal and non-Federal activities, such as urbanization, energy development, or other industrial or commercial activities, are SMALL to MODERATE. A SMALL impact would occur at sites where storage facilities have minimal impacts on air quality and no other actions occur that had overlapping, noticeable effects on air quality. A MODERATE impact would occur if other actions occur that did have overlapping and noticeable effects on air quality, such as a nearby fossil-fuel-fired electricity generating station. At storage facilities where the incremental impacts would be SMALL and the cumulative impacts would be MODERATE from other Federal or non-Federal activities, the NRC determined the cumulative impacts would likely remain MODERATE whether or not continued storage occurred because the incremental impacts from continued storage would be minor, especially in comparison to other general trends, such as operation of fossil-fuel-fired power plant.

6.4.5 Climate Change

Continued storage activities involve the emission of greenhouse gases, primarily carbon dioxide (CO₂). The quantities of greenhouse gas emissions are often described in terms of a CO₂ footprint expressed as metric tons of CO₂ equivalent. As described in Sections 4.5 and 5.5, the incremental impacts from continued storage on climate change, in terms of emissions of greenhouse gases (GHGs), are SMALL for all timeframes at both at-reactor and away-from-reactor storage facilities. The geographic area considered in the cumulative climate change analysis is worldwide.

6.4.5.1 Potential Cumulative Impacts from General Trends and Activities and from Other NRC-Regulated or Spent Fuel-Related Activities

The magnitude of cumulative impacts resulting from all general trends taking place within the region in which a storage facility is located must be placed in geographic context for the following reasons:

- The environmental impact is global rather than local or regional.
- The effect is not particularly sensitive to location of the release point.
- The magnitudes of individual GHG sources related to human activity, no matter how large compared to other sources, are small when compared to the total mass of GHGs in the atmosphere.
- The total number and variety of GHG sources is extremely large and the sources are ubiquitous.

Cumulative Impacts

These points are illustrated by the following comparison of annual CO₂ emission rates (Table 6-2).

Table 6-2. Comparison of Annual Carbon Dioxide Emission Rates

Source	MT/yr ^(a)
Global emissions from fossil-fuel combustion (2010) ^(b)	31,780,000,000
U.S. emissions from fossil-fuel combustion (2011) ^(c)	5,277,200,000
1,000-MW ^(e) nuclear power plant (including fuel cycle, 80 percent capacity factor) ^(d)	260,000
1,000-MW ^(e) nuclear power plant (during SAFSTOR) ^(d)	925
Average U.S. home ^(e)	19
Average U.S. passenger vehicle ^(e)	5

Source: (EPA 2013a, b; NRC 2013f); expressed in metric tons per year of CO₂.

(a) Nuclear power emissions estimates are in units of metric tons of CO₂-equivalent whereas the other energy alternatives emissions estimates are in units of metric tons of CO₂. If nuclear power emissions were represented in metric tons of CO₂, the value would be slightly less, as other GHG emissions would not be included.

(b) (EPA 2013a), Chapter 3; expressed in metric tons per year of CO₂.

(c) (EPA 2013a), Table 3-1; expressed in metric tons per year of CO₂.

(d) (NRC 2013f); expressed in metric tons per year of CO₂-equivalent.

(e) (EPA 2013b); expressed in metric tons per year of CO₂.

Evaluation of cumulative impacts of GHG emissions requires the use of a global climate model. The GCRP report (GCRP 2014) provides a synthesis of the results of numerous climate modeling studies. In addition, the CEQ issued draft guidance that recommends synthesis reports and peer-reviewed assessments from the GCRP as sources of the best scientific information available on reasonably foreseeable climate change impacts (CEQ 2010). The NRC concludes that the cumulative impacts of GHG emissions around the world as presented in the GCRP report are the appropriate basis for its evaluation of cumulative impacts. Based primarily on the scientific assessments of the GCRP and National Research Council, the EPA Administrator issued a determination in 2009 (74 FR 66496) that GHGs in the atmosphere may reasonably be anticipated to endanger public health and welfare, based on observed and projected effects of GHGs, their impact on climate change, and the public health and welfare risks and impacts associated with such climate change. Based on the impacts set forth in the GCRP report, and the CO₂ emissions criteria in the final EPA "Prevention of Significant Deterioration and Title V Greenhouse Gas Tailoring Rule" (75 FR 31514), the NRC concludes that the national and worldwide cumulative impacts of GHG emissions are noticeable but not destabilizing. The review team bases this conclusion that the environment may be noticeably affected by GHG emissions but not destabilized on the tailored approach to addressing CO₂ emissions in the EPA rule and the EPA Administrator's determination, neither of which call for immediate action such as closure of GHG-emitting facilities. Therefore, national and worldwide cumulative impacts of GHG emissions reflect conditions that are noticeable but not destabilizing. The NRC further concludes that the cumulative impacts would be noticeable but not destabilizing, with or without the GHG emissions from continued storage.

6.4.5.2 Conclusion

Cumulative impacts include the incremental effects from continued storage when added to the aggregate effects of other past, present, and reasonably foreseeable future actions. As described in Sections 4.5 and 5.5, the incremental impacts from continued storage on climate change is SMALL for all timeframes at both at-reactor and away-from-reactor storage facilities. In addition, past, present, and reasonably foreseeable activities take place worldwide that could contribute to climate change. The cumulative impacts from continued storage when added to other past, present, and reasonably foreseeable Federal and non-Federal activities, such as operation of fossil-fuel-fired power plants, would be MODERATE.

At storage facilities where the cumulative impacts would be MODERATE from other Federal or non-Federal activities, the NRC determined the cumulative impacts would likely remain MODERATE whether or not continued storage occurred because the incremental impacts from continued storage would be minor, especially in comparison to other GHG emitters, such as operation of fossil-fuel-fired power plant.

6.4.6 Geology and Soils

This section evaluates the effects of continued storage on geology and soils when added to the aggregate effects of other past, present, and reasonably foreseeable future actions. As described in Sections 4.6 and 5.6, the incremental impacts from continued storage on geology and soils is SMALL for all timeframes at both at-reactor and away-from-reactor storage facilities.

The geographic area considered in this cumulative analysis with regard to soils is the area within the site boundaries, and for geology is the area in the immediate vicinity of the at-reactor or away-from-reactor storage facility. Depending on the site, the area could include rural and semi-urban regions and the associated environmental conditions.

6.4.6.1 Potential Cumulative Impacts from General Trends and Activities

Cumulative impacts on the geology and soils of an area include (1) access to mineral or energy resources, (2) destruction of unique geologic features, (3) soil loss and increased erosion potential induced by construction activities, (4) soil compaction and changes to surface drainage as a result of utilities and structures, and (5) potential soil contamination (both radiological and nonradiological) through inadvertent spills during normal operations (e.g., NRC 2011a–e, 2012a, 2013a–c). These impacts typically result from land-disturbing activities, including earthmoving, grading, and excavation from constructing, operating, and decommissioning new and existing energy producing plant facilities and associated infrastructures. Land usage in the vicinity of a storage facility may also affect the access to mineral or energy resources.

Cumulative Impacts

The magnitude of geology and soils cumulative impacts resulting from general trends taking place within the region in which a storage facility is located would depend on current land utilization patterns, any proposed land-use changes, the density of impacting activities, and the extent to which these activities (facilities or projects) employ mitigation measures to reduce such impacts. The cumulative impacts from general trends and activities would range from minimal (e.g., minor ground-disturbing activities associated with localized development in the area, see NRC 2011d) to noticeable (e.g., sufficient development to noticeably disturb soil near the storage facility, see NRC 2012a).

6.4.6.2 Potential Cumulative Impacts from Other NRC-Regulated or Spent Fuel-Related Activities

Cumulative impacts on geologic resources and soils could result from other NRC-regulated or spent fuel-related activities, such as decommissioning of the reactor power block (including the spent fuel pool), ISFSI, and DTS.

Activities associated with decommissioning of the reactor that have a potential to affect soils include (1) addition and expansion of staging and laydown areas for equipment and (2) construction of temporary buildings, roads, and parking areas. In the Decommissioning GEIS for power reactors (including spent fuel pools) (NRC 2002), the NRC determined that impacts on the soils from these activities would be temporary and would not be detectable or destabilizing. For example, in the case of most reactor sites, sufficient previously disturbed areas are available for staging, laydown, and construction sites. Therefore, in the Decommissioning GEIS, it was not anticipated that additional land would need to be disturbed, thereby reducing the potential for increased soils impacts (NRC 2002). In addition, implementing best management practices (BMPs) would reduce soil erosion and compaction. These practices include, but are not limited to, minimizing the amount of disturbed land, stockpiling topsoil on laydown areas prior to use, mulching and seeding in disturbed areas, covering loose materials with geotextiles, using silt fences to reduce sediment loading to surface water, and installing proper culvert outlets to direct flows in streams or drainages. Given that the impacts from decommissioning reactors and spent fuel pools would be similar to that described in the Decommissioning GEIS for reactors, impacts on onsite soils during decommissioning of reactors and spent fuel pools are expected to be SMALL.

Activities associated with decommissioning of ISFSIs that could affect geology and soils include (1) construction of roads and parking areas used during the demolition of the storage pads, casks, and support facilities and (2) removing any contaminated soils identified (from both radiological and nonradiological inadvertent spills) during the final radiological site survey under 10 CFR Part 20, Subpart E, "Radiological Criteria for License Termination." In most cases, impacts associated with decommissioning of ISFSIs would be similar to or less than those impacts associated with construction of ISFSIs. After decommissioning activities are complete, the area previously occupied by the ISFSIs would typically be covered with topsoil, contoured,

and replanted with native vegetation (NRC 2005c). For example, the NRC assumed that the types and magnitude of impacts from decommissioning an ISFSI would be similar to that described in the Calvert Cliffs ISFSI License Renewal EA (NRC 2012b) because the facility is a typical size expected for an ISFSI and the analysis assumed typical decommissioning practices. Specifically, impacts on soils are related to the temporary disturbance of soil horizons as the ISFSI foundation is removed and leveling and regrading of the ISFSI area following decommissioning (NRC 2012b). The NRC expects that subsurface geology would not be impacted by ISFSI decommissioning because decommissioning activities typically do not extend to a depth that affects the geology (NRC 2002). Because the impacts from decommissioning at-reactor and away-from-reactors ISFSIs would be similar to that described in site-specific ISFSI EAs and EISs, impacts on geology and soils during decommissioning are expected to be SMALL.

6.4.6.3 Conclusion

Cumulative impacts on geologic resources and soils include the incremental effects from continued storage when added to the aggregate effects of other past, present, and reasonably foreseeable future actions. As described in Sections 4.6 and 5.6, the incremental impacts from continued storage on geologic resources and soils is SMALL for all scenarios at both at-reactor and away-from-reactor storage facilities. In addition, past, present, and reasonably foreseeable activities take place in the geographic area of interest that could contribute to cumulative effects to geology and soils. The cumulative impacts on geology and soils from continued storage when added to other past, present, and reasonably foreseeable Federal and non-Federal activities, such as power plant construction or urbanization, would range from SMALL to MODERATE. A SMALL impact would occur if no other actions occur that had overlapping, noticeable effects on geological resources. A MODERATE impact would occur if other Federal or non-Federal actions, such as construction of new energy facilities, had overlapping impacts with the continued storage of waste that noticeably alter soil and geological resources. At storage facilities where the cumulative impacts would be MODERATE as a result of other Federal and non-Federal activities, the NRC determined that the cumulative impacts would likely remain MODERATE whether or not continued storage occurred because the incremental impacts from continued storage would be minor, especially in comparison to other trends, such as widespread urbanization.

6.4.7 Surface-Water Quality and Use

This section evaluates the effects of continued storage on surface-water resources when added to the aggregate effects of other past, present, and reasonably foreseeable future actions. As described in Sections 4.7 and 5.7, the incremental impacts from continued storage on surface-water resources is SMALL for all timeframes at at-reactor and away-from-reactor storage facilities.

Cumulative Impacts

The geographic area considered in the cumulative surface-water resources analysis includes the portion of waterbodies (e.g., streams, rivers, ponds, estuaries, and marine waters) potentially affected by the at-reactor or away-from-reactor storage facility.

6.4.7.1 Potential Cumulative Impacts from General Trends and Activities

Potential cumulative impacts on surface waterbodies would include conflicts in consumptive water use and changes to flow patterns and chemical compositions in waterbodies receiving discharges from the reactor plant or storage facility (e.g., NRC 2011a–e, 2012a, 2013a–c). For at-reactor and away-from-reactor storage sites, cumulative impacts could occur because of multiple activities that affect the same waterbody (e.g., conflicting water demands to support urban, agricultural, commercial, and industrial developments). In addition, climate change can affect surface-water resources near at-reactor and away-from-reactor storage sites because of runoff from more intense storms, drought, flooding, and sea-level rise (GCRP 2014). For at-reactor storage facilities, additional cumulative impacts on surface-water resources would include (1) cumulative impacts due to the various impacts from an individual power plant over time (e.g., consumptive water use, altered current patterns at intake and discharge structures, altered chemical gradients) and (2) cumulative impacts due to closely sited power plants (e.g., consumptive water-use conflicts, additive effects of cooling-tower discharges on water temperature, and chemical composition) (NRC 2013a).

The magnitude of cumulative impacts resulting from all general trends taking place within the region in which a storage facility is located would depend on the nature and location of the actions relative to important waterbodies, the number and density of actions, and the extent to which these actions (i.e., facilities or projects) employ mitigation measures to minimize such impacts. The cumulative impacts from general trends and activities would range from minimal (e.g., consumptive water use from all water users in the watershed would have minor alterations to overall volume of water in the watershed, see NRC 2011d) to noticeable (e.g., the discharge and runoff of increased levels of dissolved solids, particularly during low-flow conditions, could noticeably alter water quality, see NRC 2011d). In rare situations, the cumulative impacts from general trends and activities could be destabilizing (e.g., increased water demand from power plants and the effects of climate change, especially under extreme drought conditions, could potentially destabilize a river system, see NRC 2011e).

6.4.7.2 Potential Cumulative Impacts from Other NRC-Regulated or Spent Fuel-Related Activities

Cumulative impacts on surface-water resources could result from other NRC-regulated or spent fuel-related activities, such as ground-disturbing activities that could occur during shutdown, preparation activities for transportation of waste to a repository, and decommissioning of the reactor, spent fuel pool, and ISFSI. Impacts could result from activities such as removal of shoreline or in-water structures, dredging or filling a stream or bay, runoff, and surface soil

erosion. In most cases, such surface-water disturbances and water use for dust abatement would be relatively minor and short-term in duration. Stormwater control measures, which would be required to comply with National Pollutant Discharge Elimination System (NPDES) permits, also would minimize migration of sediments or other contaminants into surface waterbodies. Dredging or filling of waterbodies would require permits from the U.S. Army Corps of Engineers (USACE), which could require additional mitigation or BMPs to minimize impacts on surface-water quality. In addition, other Federal, State, or local permits may require or suggest BMPs, and the licensee would likely implement BMPs to minimize erosion and sedimentation and control any runoff, spills, or leaks (NRC 2003, 2005c).

In the Decommissioning GEIS for power reactors (including spent fuel pools), the NRC (2002) determined that there would be minimal impact on surface-water resources and concluded that decommissioning nuclear power plants would result in SMALL impacts on surface-water resources. The NRC's EAs for the Calvert Cliffs, Humboldt Bay, and Diablo Canyon ISFSIs, and the PFSF ISFSI EIS did not identify any significant impacts on surface-water resources during decommissioning of an at-reactor, or away-from-reactor ISFSI (NRC 2003, 2005c, 2001a, 2012b). The NRC assumes that the types and magnitude of impacts from decommissioning an ISFSI at other sites would be similar to those described in the Calvert Cliffs, Humboldt Bay, and Diablo Canyon EAs and the PFSF EIS due to the limited amount of water required for decommissioning and minimal impacts from ground-disturbing activities. Given that the impacts from decommissioning reactors, spent fuel pools, and ISFSIs would be similar to those described in the Decommissioning GEIS for reactors and site-specific ISFSI EAs and EIS, impacts on surface-water resources from decommissioning are not expected to be noticeable.

6.4.7.3 Conclusion

Cumulative impacts on surface-water resources include the incremental effects from continued storage when added to the aggregate effects of other past, present, and reasonably foreseeable future actions. As described in Sections 4.7 and 5.7, the incremental impacts from continued storage on surface-water resources is SMALL for all timeframes at at-reactor and away-from-reactor storage facilities. In addition, past, present, and reasonably foreseeable activities take place in the geographic area of interest that could contribute to cumulative effects on surface-water resources. The cumulative impacts from continued storage when added to other past, present, and reasonably foreseeable Federal and non-Federal activities, such as urbanization, energy development, operation of other nearby power plants, or other water uses, would be SMALL to LARGE depending on the conditions and activities surrounding the site. A SMALL impact would occur if no other actions occur that have overlapping, noticeable effects on surface water. A MODERATE impact would occur if other Federal or non-Federal actions, such as operation of other nearby power plants or future urbanization, had overlapping impacts with the continued storage of waste that noticeably altered availability, flow patterns, and quality of

Cumulative Impacts

surface water. A LARGE impact would occur if other Federal or non-Federal actions had overlapping impacts with the continued storage of waste that destabilized surface-water resources by permanently diminishing water quantity and water quality, or adversely altering flow patterns in surface waterbodies. At storage facilities where the cumulative impacts would be MODERATE or LARGE from other Federal or non-Federal activities, the NRC determined that the cumulative impacts would likely remain MODERATE or LARGE whether or not continued storage occurred because the incremental impacts from continued storage would be minor, especially in comparison to other general trends, such as climate change.

6.4.8 Groundwater Quality and Use

This section evaluates the effects of continued storage on groundwater when added to the aggregate effects of other past, present, and reasonably foreseeable future actions. As described in Sections 4.8 and 5.8, the incremental impacts from continued storage on groundwater resources is SMALL for all timeframes at both at-reactor and away-from-reactor storage facilities.

The geographic area considered in the cumulative groundwater resources analysis includes the portion of the uppermost aquifer and offsite public groundwater wells potentially affected by the at-reactor or away-from-reactor storage facility.

6.4.8.1 Potential Cumulative Impacts from General Trends and Activities

For at-reactor storage facilities, two types of cumulative impacts on groundwater include: (1) consumptive water use at an individual power plant over time (e.g., groundwater use for the power plant's potable and reactor water makeup needs) and (2) groundwater quality degradation beneath the individual power plant due to spills and leaks (NRC 2013a). For both at-reactor and away-from-reactor storage facilities, cumulative impacts on groundwater could occur from groundwater demands associated with current and planned urban, commercial, and agricultural developments outside the storage facility site and groundwater quality degradation at the site due to past and present offsite activities. In addition, climate change and alterations in surface topography and watershed use due to new developments can affect groundwater levels and water levels in nearby surface waterbodies (e.g., lakes and rivers). These modifications could lead to changes in groundwater flow rates and reversal in groundwater flow directions at or near the site. For example, groundwater withdrawals at coastal sites could lead to saltwater intrusion. Moreover, intense use of groundwater outside the site for residential, industrial, or agricultural uses may cause land subsidence with temporary or permanent changes in local or regional groundwater hydrology.

The magnitude of cumulative impacts resulting from all actions taking place within the affected groundwater beneath and surrounding the storage facility would depend on the number of actions (facilities or projects) that draw water from the aquifer, the overall demand on the

aquifer, the hydrogeologic characteristics of the aquifer, and whether facilities follow BMPs to protect groundwater resources from degradation and overpumping. The cumulative impacts from general trends and activities would range from minimal (e.g., past and ongoing onsite and offsite activities do not cause noticeable impacts on the quality and quantity of groundwater resources, see NRC 2005d) to noticeable (e.g., past and ongoing onsite and offsite activities do not destabilize, but noticeably alter the quality or quantity of groundwater resources, see NRC 2011f). In rare situations, the cumulative impacts from general trends and activities could be destabilizing (e.g., groundwater beneath the site and adjacent areas has been adversely affected and noticeably destabilized by past and ongoing onsite and offsite activities, see NRC 2012c).

6.4.8.2 Potential Cumulative Impacts from Other NRC-Regulated or Spent Fuel-Related Activities

Cumulative impacts on groundwater resources could result from other NRC-regulated or spent fuel-related activities, such as ground-disturbing activities that could occur during shut down activities; preparation activities for transportation of waste to a repository; as well as during decommissioning of the reactor, spent fuel pool, and ISFSI. Direct impacts could result from activities such as removal of shoreline, active dredging, or filling of a stream or bay. Indirect impacts may result from effects such as downward infiltration or seepage of contaminated surface water, oil, or other fluids from disturbed ground surface or streams into underlying groundwater; or from inadvertent changes in horizontal hydraulic gradients from the site to the nearest surface waterbody. These types of impacts could alter groundwater quality and flow rates, reverse groundwater flow directions, and induce saltwater intrusion at sites near the ocean. In most cases, however, groundwater disturbances would result in relatively minor impacts (NRC 2002). Water demand for power plant operational cooling would decrease during final power reactor shutdown activities and decommissioning. Water withdrawals would continue to be subject to applicable water appropriation or allocation permit requirements, as well as Clean Water Act Section 316(b) requirements for minimizing adverse environmental impacts associated with the use of cooling-water intake structures. This would also limit the impact on surficial groundwater systems. NPDES permits would prescribe effluent limits for the facility's surface-water discharge to minimize the potential for indirect contamination of groundwater. Dredging or filling of waterbodies would require permits from the USACE, which could require additional mitigation or BMPs to minimize inadvertent changes in site hydrogeology and the potential for seawater intrusion at a site near the ocean.

In the Decommissioning GEIS for nuclear power reactors (including spent fuel pools), the NRC (2002) determined that there would be minimal impact on groundwater use and quality and concluded that decommissioning nuclear power plants would result in SMALL impacts on groundwater. The NRC's EAs and EISs for the Calvert Cliffs, Humboldt Bay, and Diablo Canyon ISFSIs, and the PFSF ISFSI EIS did not identify any significant impacts on groundwater resources during decommissioning of an at-reactor, or away-from-reactor ISFSI (NRC 2001a,

Cumulative Impacts

2003, 2005c, 2012b). The NRC assumes that the types and magnitude of impacts from decommissioning an ISFSI at other sites would be similar to those described in the Calvert Cliffs, Humboldt Bay, and Diablo Canyon EAs and the PFSF EIS because a similar amount of water use is expected. Given that the impacts from decommissioning reactors, spent fuel pools, and ISFSIs would be similar to those described in the Decommissioning GEIS for reactors and site-specific ISFSI EAs and EIS, impacts on groundwater from decommissioning are expected to be SMALL.

6.4.8.3 Conclusion

Cumulative impacts on groundwater resources include the incremental effects from continued storage when added to the aggregate effects of other past, present, and reasonably foreseeable future actions. As described in Sections 4.8 and 5.8, the incremental impacts from continued storage on groundwater resources is SMALL for all timeframes at both at-reactor and away-from-reactor storage facilities. In addition, past, present, and reasonably foreseeable activities take place in the geographic area of interest that could contribute to cumulative effects to groundwater. The cumulative impacts from continued storage when added to other past, present, and reasonably foreseeable Federal and non-Federal activities; such as urbanization, energy development, landfills, agricultural, industrial, or other water users; range from SMALL to LARGE depending on the conditions and activities surrounding the site. A SMALL impact would occur if continued storage and no other actions occur that have overlapping, noticeable effects on groundwater. A MODERATE impact would occur if other Federal or non-Federal actions, such as operation of other nearby power plants or future urbanization, had overlapping impacts with the continued storage of waste that noticeably altered groundwater quality and/or with the continued withdrawals of groundwater that may adversely impact site groundwater hydrology. A LARGE impact would occur if elevated radionuclide concentrations in groundwater from past and ongoing onsite and offsite activities or significant changes in groundwater hydrology at or near the site (e.g., altered hydraulic interactions between underlying shallow and confined aquifers, or groundwater flow reversal, which may lead to saltwater intrusion at a site near the ocean) occur that would destabilize the quality and quantity of groundwater resources. At storage facilities where the cumulative impacts would be MODERATE or LARGE from other Federal or non-Federal activities, the NRC determined that the cumulative impacts would likely remain MODERATE or LARGE whether or not continued storage occurred because the incremental impacts from continued storage would be minor, especially in comparison to other general trends, such as climate change.

6.4.9 Terrestrial Resources

This section evaluates the effects of continued storage on terrestrial resources, including terrestrial special status species and habitats, when added to the aggregate effects of other past, present, and reasonably foreseeable future actions. As described in Section 4.9, the incremental impact on terrestrial resources from continued storage is SMALL for at-reactor

storage facilities during all timeframes. As described in Section 5.9, the incremental impacts at away-from-reactor storage facilities during the short-term timeframe would be SMALL to MODERATE, depending on whether construction activities noticeably alter suitable habitat for local terrestrial species. During the long-term and indefinite storage timeframes, the impacts at away-from-reactor storage facilities would be SMALL.

The geographic area considered includes terrestrial habitats on or adjacent to the at-reactor or away-from-reactor storage facility site affected by continued storage as well as other terrestrial habitats in the surrounding landscape closely interconnected by movement or migration of species. In addition, terrestrial ecology evaluations focus on the habitats and species, both plants and animals, within an ecosystem.

6.4.9.1 Potential Cumulative Impacts from General Trends and Activities

Cumulative impacts on terrestrial habitats and wildlife may occur because of habitat loss and degradation, disturbance and displacement, injury and mortality, and obstruction of movement (e.g., NRC 2011a–e, 2012a, 2013a–c). Factors that could influence impacts on terrestrial resources include exposure to elevated noise levels and contaminants, altered surface-water and groundwater quality and flow patterns, and hazards associated with direct contact with physical structures (e.g., bird collisions with buildings and other structures). Adverse impacts typically result from activities (e.g., construction) associated with urbanization, industrial and commercial development, agricultural development, transportation development, water projects, and regional tourism and recreation. Migratory and mobile species may be affected by activities carried out in locations remote from the storage facility site. Vegetative communities (including floodplain and wetland communities) also may be affected by activities (e.g., clearing and grading) associated with these actions, thus creating conditions favorable for invasive species to establish in the area.

Climate change may add to the cumulative impact on terrestrial species and habitats (e.g., NRC 2011a–e, 2012a, 2013a–c). Climate models project that there will be changes in precipitation rates in the United States and that these changes could alter the character of terrestrial habitats (GCRP 2014). This could further stress terrestrial resources affected by the activities described above. For example, reduced precipitation could contribute to drawdowns in some cooling-water sources and contribute to impacts on shoreline habitats of those systems. Certain areas might experience increased, instead of decreased, precipitation. In these areas, increased precipitation and sea-level rise could inundate low-lying areas at coastal facilities (e.g., NRC 2011d). Storm frequency and intensity also could increase, and temperatures could vary. The position of ecoregions can be expected to shift in response to these changes, and terrestrial ecosystems can be expected to experience gradual transitions that will stress species and habitats (GCRP 2014). Similarly, species ranges may shift in accordance with the changing environmental conditions and habitats (GCRP2014). During continued storage, a shift in species ranges could result in a storage facility affecting certain species that were not present

Cumulative Impacts

prior to continued storage. If the species is protected under the Endangered Species Act of 1973, as amended (ESA), and if the criteria in 50 CFR Part 402 are met for initiation or reinitiation of Section 7 consultation, the NRC would be required to initiate or reinitiate ESA Section 7 consultation with the U.S. Fish and Wildlife Service (FWS) or National Marine Fisheries Service (NMFS). As described in Section 4.11, the NRC would evaluate any potential impacts on those species and FWS or NMFS may require mitigation to minimize impacts on those species.

The magnitude of cumulative impacts resulting from all general trends taking place within the region in which a storage facility is located would depend on the nature and location of the actions relative to important terrestrial resources, the number (and density) of actions, and the extent to which these actions (facilities or projects) employ mitigation measures to minimize such impacts. The cumulative impacts from general trends and activities would range from minimal (e.g., temporary and minor changes to terrestrial habitat from limited development in the area, see NRC 2011b) to noticeable (e.g., noticeable wetland loss and fragmentation of wetland and upland forest habitats, see NRC 2012a).

6.4.9.2 Potential Cumulative Impacts from Other NRC-Regulated or Spent Fuel-Related Activities

Cumulative impacts on terrestrial resources could result from other NRC-regulated or spent fuel-related activities, such as ground-disturbing activities that could occur during shutdown activities; preparation activities to transport waste to a repository; and decommissioning of the reactor, spent fuel pool, and ISFSI. For example, incremental impacts could result from shoreline activities (dredging or filling of wetlands), operation of the cooling system on shoreline vegetation (water withdrawal and discharge water temperature increases), and habitat disturbance and fragmentation from development or removal of infrastructure and power transmission-line and cooling-water pipeline rights-of-ways to support future projects.

Incremental impacts from continued storage may result from effects such as runoff because of ground-disturbing activities and surface erosion. To help protect terrestrial habitats, stormwater control measures, which would be required to comply with NPDES permitting, would minimize erosion and the flow of disturbed soils or other contaminants into terrestrial habitats. Some activities could require permits from the USACE, which would require mitigation for impacts on jurisdictional wetlands. Consultation with the FWS and other Federal, State, or local groups could result in the identification of additional mitigation or BMPs to minimize impacts on terrestrial resources from noise, dust, migratory bird collisions with crane booms or other construction equipment, and habitat alteration from introduction of invasive plant species. In most cases, terrestrial disturbances would result in relatively minor, short-term impacts (e.g., NRC 2006, 2011e).

In the Decommissioning GEIS for power reactors (including spent fuel pools), NRC (2002) determined that terrestrial resources resulting from activities occurring within the facility's operational areas would be SMALL. The NRC's EAs for the Calvert Cliffs (NRC 2012b), Humboldt Bay (NRC 2005c), and Diablo Canyon ISFSIs (NRC 2003), and the PFSF ISFSI EIS (NRC 2001a) did not identify any significant impacts on terrestrial resources during decommissioning of an at-reactor or away-from-reactor ISFSI. The NRC assumes that the types and magnitude of impacts from decommissioning an ISFSI at other sites would be similar to that described in the Calvert Cliffs, Humboldt Bay, and Diablo Canyon EAs and the PFSF EIS because of the limited size and minimal impacts from ground-disturbing activities. Therefore, impacts from decommissioning would likely result in relatively short-term impacts and, most of the time, within previously disturbed areas. Given that the impacts from decommissioning reactors, spent fuel pools, and ISFSIs would be similar to impacts described in the Decommissioning GEIS for reactors and site-specific ISFSI EAs and EIS, impacts on terrestrial resources from decommissioning are expected to be minimal.

6.4.9.3 Conclusion

Cumulative impacts on terrestrial resources include the incremental effects from continued storage when added to the aggregate effects of other past, present, and reasonably foreseeable future actions. As described in Section 4.9, the incremental impact from continued storage on terrestrial resources is SMALL for at-reactor storage facilities during all timeframes. As described in Section 5.9, the incremental impacts at away-from-reactor storage facilities during the short-term timeframe would be SMALL to MODERATE, depending on whether construction activities noticeably alter suitable habitat for local terrestrial species. During the long-term and indefinite storage timeframes, the impacts at away-from-reactor storage facilities would be SMALL. In addition, past, present, and reasonably foreseeable activities that take place in the geographic area of interest could contribute to cumulative effects to terrestrial resources. The cumulative impacts from continued storage when added to other past, present, and reasonably foreseeable Federal and non-Federal activities, such as urbanization and energy development, range from SMALL to MODERATE depending on the conditions and activities surrounding the site. At sites where continued storage has minimal impacts on terrestrial resources and no other actions occur that have overlapping, noticeable effects on terrestrial resources, the cumulative impacts can be expected to be SMALL. At sites where construction of an away-from-reactor storage facility has noticeably altered terrestrial resources, or other actions have overlapping, noticeable effects on terrestrial resources, the cumulative impacts can be expected to be MODERATE. For example, in more urbanized areas where certain habitats are limited, MODERATE cumulative impacts may be possible if other Federal or non-Federal actions, such as operation of other nearby power plants or future urbanization, have overlapping impacts with the continued storage of waste that noticeably altered terrestrial resources. For at-reactor storage facilities where the cumulative impacts would be MODERATE from other Federal or non-Federal activities, the NRC determined that the cumulative impacts would likely remain

Cumulative Impacts

MODERATE whether or not continued storage occurred because the incremental impacts from an at-reactor continued storage facility would be minor, especially in comparison to other general trends, such as climate change or urbanization.

6.4.10 Aquatic Resources

This section evaluates the effects of continued storage on aquatic resources, including aquatic special status species, when added to the aggregate effects of other past, present, and reasonably foreseeable future actions. As described in Sections 4.10 and 5.10, the incremental impacts from continued storage on aquatic resources is SMALL for all timeframes at both at-reactor and away-from-reactor storage facilities.

The geographic area considered in this analysis includes affected aquatic habitats on or adjacent to the at-reactor or away-from-reactor storage facility site as well as other aquatic habitats in the surrounding landscape closely interconnected by movement or migration of species using affected habitats. Depending on the site, this could include the potentially affected portion of streams, rivers, ponds, lakes, estuaries, or nearshore habitats of marine waters.

6.4.10.1 Potential Cumulative Impacts from General Trends and Activities

Cumulative impacts on aquatic habitats and species can include (1) loss and degradation of habitat; (2) species disturbance, displacement, injury, and mortality; (3) obstruction of movement; and (4) introduction and spread of invasive species and diseases (as described in NRC 2011a–e, 2012a, 2013a–c). These impacts result from many general trends identified in Table 6-1, such as industrial, commercial, agricultural, and transportation development; increased water use and discharges to natural waterbodies from power plant operations (including potential replacement power); habitat modification associated with urbanization and water development projects; commercial and recreational fishing; and regional tourism and recreation. For aquatic resources near at-reactor storage facilities, additional cumulative impacts may include impacts from an individual power plant over time (e.g., entrainment, impingement, radiological impacts, thermal discharges, and chemical discharges from the power plant), (2) the cumulative impacts due to closely sited power plants (e.g., the additive effects of entrainment, impingement, radiological impacts, thermal discharges, and chemical discharges from all nearby power plants), and (3) cumulative impacts due to multiple general trends that affect the same waterbody at the reactor (e.g., dams, agriculture, urban, and industrial development) (NRC 2013a).

Climate change may add to the cumulative impact on aquatic species and habitats (e.g., NRC 2011a–e, 2012a, 2013a–c). Changes to aquatic habitats could result from increased runoff, increased surface-water temperature, increased storm intensity and frequency, sea-level rise, ocean acidification, and other biological stressors (GCRP 2014). The position of

ecoregions can be expected to shift in response to these changes, and marine ecosystems can be expected to experience gradual transitions, which would stress species and habitats. Similarly, species ranges may shift in correspondence to the changing environmental conditions and habitats (GCRP 2014). In addition, cooling system operations or other activities could increase the mortality of phytoplankton and macroalgae, which sequester atmospheric CO₂. A reduction in these populations could mean that fewer organisms would be present to sequester atmospheric CO₂, which may contribute to climate change.

During continued storage, a shift in species ranges due to climate change or other activities could result in a storage facility affecting certain species that were not present prior to continued storage. If the species is protected under the ESA, and if the criteria in 50 CFR Part 402 are met for initiation or reinitiation of Section 7 consultation, the NRC would be required to initiate or reinitiate ESA Section 7 consultation with the FWS or NMFS. As described in Section 4.11, the NRC would evaluate any potential impacts on those species, and the FWS or NMFS may require mitigation to minimize impacts on those species.

The magnitude of cumulative impacts resulting from all general trends taking place within the region in which a storage facility is located would depend on the nature and location of the actions relative to important waterbodies, the number (and density) of actions, and the extent to which these actions (facilities or projects) employ mitigation measures to minimize such impacts. The cumulative impacts from general trends and activities would range from minimal (e.g., temporary and minor changes to aquatic habitat from limited development in the area, see NRC 2011c) to noticeable (e.g., past power plant operations resulting in a noticeable decline for certain fish species, see NRC 2012a). In rare situations, the cumulative impacts from general trends and activities could be destabilizing (e.g., if cold-water fish species significantly decline in population as a result of simultaneously being subjected to impingement and entrainment, intense commercial fishing efforts, and warmer waters from climate change, see NRC 2011g).

6.4.10.2 Potential Cumulative Impacts from Other NRC-Regulated or Spent Fuel-Related Activities

Cumulative impacts on aquatic resources could result from other NRC-regulated or spent fuel-related activities, such as shutdown activities; preparing waste for transportation to a repository; and decommissioning of the reactor power block (including the spent fuel pool), ISFSIs, and DTS. Ground-disturbing activities could include the removal of shoreline or in-water structures or the active dredging or filling of a stream or bay, which could result in increased runoff and surface erosion. In most cases, impacts on aquatic resources would be minor and short-term. Aquatic habitats would likely be protected by stormwater control measures, which would minimize the flow of disturbed soils or other contaminants into aquatic features. These measures would be required to comply with NPDES permits. Dredging or filling of waterbodies would require permits from the USACE, which could require additional mitigation or BMPs to minimize impacts on aquatic resources. In addition, other Federal, State, or local permits may

Cumulative Impacts

require or suggest BMPs that the licensee would likely implement to minimize erosion and sedimentation and control any runoff, spills, or leaks (e.g., NRC 2003, 2005c).

Shutdown activities could alter aquatic habitats as the amount of thermal discharge decreases or ceases entirely. For example, some aquatic organisms, such as manatees, congregate and overwinter in waters that are warmer than the surrounding water because of thermal discharge from the plant. As a result, manatees as well as other organisms, such as, sea turtles, or fish, could experience cold shock because of the change in temperature. Some of these species are protected under the ESA. As described in Section 4.11, for nuclear power plants with a Biological Opinion, the NRC would need to reinitiate consultation with the FWS or NMFS if there is a significant change in the plant parameters described in the Biological Opinion that could affect listed species or designated critical habitats in a manner or to an extent not previously considered, such as reduced thermal discharge, and if the criteria in 50 CFR 402.16 are met for reinitiation of Section 7 consultation. Consultation under the ESA would include an assessment and potential mitigation factors to offset cold shock or other potential impacts on listed species. In addition, operation of the spent fuel pool would reduce this impact because some thermal discharge would be expected during spent fuel pool operations, as described in Section 4.10.

In the Decommissioning GEIS for power reactors (including spent fuel pools), the NRC (2002) determined that there would be minimal impact on aquatic resources and concluded that decommissioning nuclear power plants would result in SMALL impacts on aquatic resources. The NRC's EAs for the Calvert Cliffs, Humboldt Bay, and Diablo Canyon ISFSIs, and the PFSF ISFSI EIS did not identify any significant impacts on aquatic resources during decommissioning of an at-reactor or away-from-reactor ISFSI (NRC 2001a, 2003, 2005c, 2012b). The NRC assumes that the types and magnitude of impacts from decommissioning an ISFSI at other sites would be similar to that described in the previous EAs and EIS because of the limited amount of water required for decommissioning and minimal impacts from ground-disturbing activities. Given that the impacts from decommissioning reactors, spent fuel pools, and ISFSIs would be similar to that described in the Decommissioning GEIS for reactors and site-specific ISFSI EAs and EISs, impacts on aquatic resources from decommissioning is expected to be minimal.

6.4.10.3 Conclusion

Cumulative impacts on aquatic resources include the incremental effects from continued storage when added to the aggregate effects of other past, present, and reasonably foreseeable future actions. As described in Sections 4.7 and 5.7, the incremental impacts from continued storage on aquatic resource is SMALL for all timeframes at both at-reactor and away-from-reactor storage facilities. In addition, past, present, and reasonably foreseeable activities take place in the geographic area of interest that could contribute to cumulative effects on aquatic resources. The cumulative impacts from past, present, and reasonably foreseeable Federal and non-Federal activities; such as urbanization, energy development, or other water users; would range from SMALL to LARGE depending on the conditions and activities surrounding the

site. At sites where the surrounding development has been limited and no other actions occur that have overlapping, noticeable effects on aquatic resources, the cumulative impacts can be expected to be SMALL. MODERATE cumulative impacts could occur if other Federal or non-Federal actions, such as operation of other nearby power plants or future urbanization, had overlapping impacts with the continued storage of waste that noticeably altered aquatic resources. LARGE impacts are not as likely but could occur under exceptional circumstances such as if other Federal or non-Federal actions, such as intense fishing pressure or changes in aquatic habitats from climate change, had overlapping impacts with the continued storage of waste that destabilized aquatic resources. At storage facilities where the cumulative impacts would be MODERATE or LARGE from other Federal or non-Federal activities, the NRC determined that the cumulative impacts would likely remain MODERATE or LARGE whether or not continued storage occurred because the incremental impacts from continued storage would be minor, especially in comparison to other general trends, such as climate change or fishing.

6.4.11 Historic and Cultural Resources

This section evaluates the effects of continued storage on historic and cultural resources when added to the aggregate effects of other past, present, and reasonably foreseeable future actions. As described in Sections 4.12 and 5.12, the incremental impacts from continued storage on historic and cultural resources would be SMALL (no impacts on historic and cultural resources) during short-term storage for at-reactor ISFSIs. During short-term for away-from reactor ISFSIs and during long-term and indefinite storage timeframes at away-from-reactor and at-reactor ISFSIs, the impacts could range from SMALL to LARGE.

The geographic area considered in the cumulative historic and cultural resources analysis includes the area of potential effect that may be affected by land-disturbing or other operational activities associated with continued storage of spent fuel, including the viewshed. This determination is made irrespective of land ownership or control. Cumulative impacts on historic and cultural resources relate to the damage or destruction of these resources (i.e., archaeological sites, historic structures, and traditional cultural properties, or their context). Impacts to historic and cultural resources (e.g., archaeological sites or historic structures) would occur if these resources in the area of potential effect are physically removed or disturbed. In this regard, potential cumulative impacts for this resource area are localized and limited to the area of physical disturbance. Impacts could occur if a licensing action results in the introduction of significant visual intrusions within the viewshed. Historic and cultural resources are nonrenewable resources that are affected by natural and man-made actions. Once these resources are removed or destroyed, they cannot be restored, rebuilt, or repaired; therefore, the impact of destruction of historic and cultural resources is a cumulative impact.

Cumulative Impacts

6.4.11.1 Potential Cumulative Impacts from General Trends and Activities

Cumulative impacts on historic and cultural resources typically result from ground-disturbing activities (e.g., earthmoving, blasting, grading, and excavation) within the area of potential effect and are site-specific. Impacts could occur from activities associated with new energy projects (e.g., replacement power facilities) or potential industrial, commercial, agricultural, and transportation if development occurs within the area of potential effect (NRC 2013a). For example, if a new energy project is co-located with the existing at-reactor or away-from-reactor ISFSI, there could be adverse impacts on historic properties or historic and cultural resources associated with the construction and operation of the new facility. Such activities may directly damage or destroy cultural artifacts or increase the potential for their exposure by accelerating erosion, leaving them vulnerable to theft and vandalism.

The magnitude of cumulative impacts resulting from general trends taking place within and surrounding the area of potential effect would depend on the nature and location of the actions (facilities or projects), what resources are present, the extent of land disturbance, whether cultural resource surveys are conducted, and the extent to which these actions employ mitigation measures. Additionally, only Federal undertakings require compliance with the National Historic Preservation Act (NHPA) Section 106 procedural requirements. However, some States have similar procedural or environmental review requirements. Cumulative impacts can range from minimal (e.g., no impacts on historic and cultural resources, see NRC 2011g) to noticeable (e.g., construction and operation of a new coal-fired power plant or new transmission lines would result in a noticeable impact on historic and cultural resources, see NRC 2011c), to destabilizing (e.g., impacts on three National Register listed/eligible historic properties including two historic buildings/structures—Baltimore & Drum Point Railroad [CT-1259] and Camp Conoy [CT-1312]—and one archaeological site [18CV474] that may be the remnants of a residence associated with the lives of slaves and/or tenants, sharecroppers, or freed African Americans, see NRC 2011d).

6.4.11.2 Potential Cumulative Impacts from Other NRC-Regulated or Spent Fuel-Related Activities

Cumulative impacts on historic and cultural resources could result from other NRC-regulated or spent fuel-related activities, such as decommissioning of the reactor power block (including the spent fuel pool), ISFSI, and DTS.

The environmental impacts associated with reactor decommissioning were assessed in the Decommissioning GEIS (NRC 2002). Activities associated with decommissioning of the reactor power block (including the spent fuel pool) that could affect historic and cultural resources include (1) addition and expansion of staging and laydown areas for equipment, (2) construction of temporary buildings and parking areas, (3) stabilization, (4) decontamination and dismantlement, and (5) removal of large reactor components (NRC 2002, 2013a). These

activities could affect cultural resources primarily via land disturbance, which could damage or destroy the resource, or alter the contextual setting of historic and cultural resources (NRC 2002). Decommissioning activities conducted within the operational areas (i.e., the power block) are not expected to affect historic and cultural resources because much of the land within and immediately surrounding the power block was extensively disturbed during initial nuclear power plant construction. Therefore, if ground-disturbing activities are limited to operational areas, impacts on historic and cultural resources would be SMALL (NRC 2002). Should ground-disturbing activities occur outside of power block, some impacts could be noticeable or destabilizing; there could be impacts on historic and cultural resources (NRC 2002). Prior to ground-disturbing activities commencing in areas outside the power block area, cultural resource surveys should be conducted to identify and protect any historic properties and other historic and cultural resources (i.e., adherence to management plans and procedures).

Activities associated with decommissioning of ISFSIs include dismantling and removing the concrete storage casks, concrete pads, and support facilities, including the DTS, and removing any contaminated soils identified during the final radiological site survey. A review of NRC EAs and EISs for specifically licensed at-reactor and away-from-reactor ISFSIs did not identify any significant impacts on historic and cultural resources during decommissioning (e.g., NRC 2001a, 2003, 2005a–c, 2009, 2012b). However, prior to decommissioning activities commencing, a final decommissioning plan must be submitted to the NRC for review and approval in accordance with 10 CFR 72.54(g)(1)–(6), 72.54(d), and 72.54(i). Impacts associated with eventual decommissioning of the generally licensed ISFSI would be considered when a licensee submits its post-shutdown decommissioning activities report for review under 10 CFR 50.82(a)(4) or 10 CFR 52.110(d)(1) and its license termination plan for review and approval per 10 CFR 50.82(a)(9) or 10 CFR 52.110(i). NRC authorization of a final decommissioning plan or license termination plan would constitute Federal actions under NEPA and would be undertakings under the NHPA. The site-specific environmental review and compliance with the NHPA process could identify historic properties, adverse effects and potentially resolve adverse effects to historic properties and impacts on other historic and cultural resources. After decommissioning is completed, the area previously occupied by the at-reactor or away-from-reactor ISFSI would typically be covered with topsoil, contoured, and replanted with native vegetation (NRC 2005a). Should ground-disturbing activities occur outside of the ISFSI footprint, some impacts could be noticeable or destabilizing. The magnitude of impact largely depends on what resources are present, the extent of proposed land disturbance, if the area has been previously surveyed, and if the licensee has management plans and procedures that are protective of historic and cultural resources.

6.4.11.3 Conclusion

Cumulative impacts on historic and cultural resources include the incremental effects from continued storage when added to the aggregate effects of other past, present, and reasonably

Cumulative Impacts

foreseeable future actions. As described in Sections 4.12 and 5.12, the incremental impacts from continued storage on historic and cultural resources would be SMALL for the short-term timeframe for an at-reactor ISFSI; during the short-term for away-from-reactor ISFSIs and during long-term and indefinite storage timeframes at away-from-reactor and at-reactor ISFSIs, the impacts could range from SMALL to LARGE. This range takes into consideration routine maintenance and monitoring (i.e., no ground-disturbing activities), the absence or avoidance of historic and cultural resources, and potential ground-disturbing activities that could affect historic and cultural resources. In addition, the analysis also considers uncertainties inherent in analyzing this resource area over long timeframes. These uncertainties include any future discovery of previously unknown historic and cultural resources; resources that gain significance within the vicinity and the viewshed (e.g., nomination of a historic district) due to improvements in knowledge, technology, and excavation techniques; and changes associated with predicting resources that might be significant to future generations. In addition, past, present, and reasonably foreseeable activities take place in the area of potential effect that could also contribute to cumulative effects to historic and cultural resources. The cumulative impacts on historic and cultural resources from continued storage when added to other past, present, and reasonably foreseeable Federal and non-Federal activities could be SMALL to LARGE which could include resources that are present, the extent of proposed land disturbance, previous surveys, and management plans and procedures that are protective of historic and cultural resources. The effect of the actions would be a SMALL impact at sites where continued storage and no other actions occur that have overlapping, noticeable effects on historic and cultural resources within the area of potential effect. MODERATE to LARGE impacts could occur at sites where NRC, or other Federal or non-Federal actions (such as new energy projects and other forms of potential development within and surrounding the area of potential effect), have overlapping impacts with the continued storage of waste that noticeably affect or destabilize historic and cultural resources.

6.4.12 Noise

This section evaluates the effects of continued storage on noise when added to the aggregate effects of other past, present, and reasonably foreseeable future actions. As described in Sections 4.13 and 5.13, the incremental impacts from continued storage on noise is SMALL overall for all timeframes for both at-reactor and away-from-reactor storage facilities.

The geographic area considered in the cumulative noise analysis extends in a radius of about 7.7 km (4.8 mi) from the noise sources originating from an at-reactor or away-from-reactor storage facility site. At a distance of about 3.9 km (2.4 mi) from a noise source, most sound levels would be reduced to less than the 55-dB(A) EPA-recommended threshold for protection against outdoor activity interference and annoyance. A receptor can be affected by noise sources from the at-reactor and away-from-reactor ISFSIs up to about 3.9 km (2.4 mi) away. Therefore, the NRC considered other noise sources within a 3.9 km (2.4 mi) radius of the

receptor for potential cumulative effects. This effectively creates a cumulative geographic area of interest within a 7.7 km (4.8 mi) radius from the spent fuel noise sources.

6.4.12.1 Potential Cumulative Impacts from General Trends and Activities

Noise levels in the vicinity of a storage facility could be the result of activities (e.g., traffic) associated with urban, industrial, and commercial development (including transportation development) and water projects (e.g., NRC 2011a–e, 2012a, 2013a–c). The magnitude of cumulative impacts resulting from all general trends would depend on the plant's proximity to these activities. Because noise impacts cease once an activity stops, the noise would need to occur at the same time as continued storage in order for the impacts to be overlapping or cumulative.

The magnitude of cumulative impacts resulting from all general trends taking place within the cumulative geographic area of interest would (1) be dominated by the loudest audible source because noise does not add linearly and (2) depend on the sound level generated by the noise sources and the proximity of the receptor to the noise sources. The cumulative impacts from general trends and activities would range from minimal (e.g., the sound levels generated by the noise sources and proximity of these sources to receptors only produce minor impacts, see NRC 2011d), to noticeable (e.g., potential noise levels from cooling-water system pumps associated with the operation of co-located nuclear reactor units, see NRC 2011e). The NRC also acknowledges that the noise impacts from operation of a fossil-fuel power plant near a storage facility could result in noticeable impacts (e.g., delivery of coal and limestone by train, see NRC 2011e).

6.4.12.2 Potential Cumulative Impacts from Other NRC-Regulated or Spent Fuel-Related Activities

Cumulative noise impacts could result from other NRC-regulated or spent fuel-related activities, such as (1) decommissioning of the reactor power block (including the spent fuel pool), ISFSI, and DTS; (2) loading of packages for transportation to a repository; and (3) long-range transportation of spent fuel.

The primary noise source associated with decommissioning of the power reactor block is the use of construction equipment to dismantle and remove buildings and structures. The Decommissioning GEIS (NRC 2002) analyzed noise impacts for decommissioning a reactor (including the spent fuel pools) and determined that the noise impacts would not be noticeable enough to routinely disrupt human activity. However, this analysis was based on the implementation of some mitigation measures (e.g., restrictions on when noise producing activities could be conducted). Unmitigated impacts, however, could be disruptive to human activity. Such mitigation measures may not be required by Federal regulations, but may be required by local ordinances. Given that the impacts from decommissioning reactors and spent

Cumulative Impacts

fuel pools considered in this GEIS would be similar to that described in the Decommissioning GEIS, the impacts on at-reactor facilities during decommissioning are expected to be minimal.

The primary noise source associated with decommissioning of an ISFSI and DTS is the use of construction equipment to dismantle and remove concrete storage casks, concrete pads, and support facilities. Although ISFSI decommissioning was not addressed in the Decommissioning GEIS, it was addressed in the PFSF EIS (NRC 2001a). The PFSF EIS concluded that the impacts overall were SMALL. However, the conclusion was based on the fact that the distance between the noise source and nearest resident was 3 km (2 mi) and the 95 dB(A) sound levels at the source would be reduced to ambient conditions at those distances. In a broader application for other locations, the distance between noise source and receptor is important when assessing whether the sound levels alter noticeably important attributes of the source.

The loading of packages for transportation to a repository would have similar noise sources, noise levels, and impact magnitude as the receiving of spent fuel at an away-from-reactor facility from at-reactor locations as described in Section 5.1.2. Therefore, close to the source, noise levels would exceed the 55 dB(A) EPA-recommended level for protection against outdoor activity and interference and annoyance. At distances greater than about 3.9 km (2.4 mi), the noise level of 100 dB(A) at the source would be reduced to below this EPA-recommended protection level.

Disposal of spent fuel requires long-range transportation from the storage site to a repository. The at-reactor storage operation examines the impacts of a facility with a 1,600-MTU capacity, whereas the away-from-reactor storage operation examines the impacts of a facility with a 40,000-MTU capacity. The Yucca Mountain EIS (DOE 2008) assessed the noise impacts at the national and state levels for long-range transport of 70,000 MTHM of spent fuel to the repository. The Yucca Mountain EIS concluded that the noise impacts would be small at the national level in comparison with the impacts of other nationwide transportation activities. At the state level, noise could be noticeable in situations where receptors were near transportation routes. Because the amount of spent fuel and the associated number of shipments (i.e., the frequency at which the source generates noise) considered in the transportation analyses for an at-reactor or away-from-reactor storage site is less than that considered in the Yucca Mountain analyses, the NRC concludes that the transportation noise impacts for an at-reactor or away-from-reactor site would not be greater than the impact magnitude defined in the Yucca Mountain EIS.

6.4.12.3 Conclusion

Cumulative noise impacts include the incremental effects from continued storage when added to the aggregate effects of other past, present, and reasonably foreseeable future actions. As described in Sections 4.13 and 5.13, the incremental impacts from continued storage on noise is overall SMALL for all timeframes at both at-reactor and away-from-reactor storage facilities.

In addition, past, present, and reasonably foreseeable activities take place in the geographic area of interest that could contribute to cumulative effects to noise. The cumulative impacts from continued storage when added to other past, present, and reasonably foreseeable Federal and non-Federal activities, such as activities from industrial and commercial development, are SMALL to MODERATE depending on the noise sources and proximity to receptors. In most cases, a SMALL cumulative impact would be expected and would occur if no other actions had overlapping, noticeable effects that altered important attributes of the noise. A MODERATE impact could occur if other actions occur that did have overlapping and noticeable impacts that altered important noise attributes such as operation of a nearby fossil-fuel-fired power plant. At storage facilities where the cumulative impacts would be MODERATE from other Federal or non-Federal activities, the NRC determined that the cumulative impacts would likely remain MODERATE whether or not continued storage occurred because the incremental impacts from continued storage would be minor, especially in comparison to other general trends, such as operation of a fossil-fuel-fired power plant.

6.4.13 Aesthetics

This section evaluates the effects of continued storage on aesthetic resources when added to the aggregate effects of other past, present, and reasonably foreseeable future actions. As described in Sections 4.14 and 5.14, the incremental impacts from continued storage on aesthetics is SMALL for all timeframes for an at-reactor storage facility, and SMALL to MODERATE for an away-from-reactor storage facility. The geographic area considered in the cumulative aesthetic resources analysis includes the area from which the at-reactor or away-from-reactor storage facility is visible.

6.4.13.1 Potential Cumulative Impacts from General Trends and Activities

Cumulative impacts on aesthetic resources come from changes to the visual appeal of a tract of land. The magnitude of cumulative impacts on aesthetic resources depends on the degree to which the facility contrasts adversely with the existing landscape and is a function of the visibility of dry storage pads, canisters, and handling facilities from neighborhoods or roads, across waterbodies, or from higher topographic elevations. The visibility of at-reactor ISFSIs is generally lower than the nuclear power plant because of the lower profile of the storage facility. Cumulative impacts also depends in part on the degree of public interest and concern over potential changes to the existing scenic quality.

The continuation of general trends occurring at or near nuclear power plants and storage facilities could result in overlapping aesthetic impacts during continued storage. For example, the construction and operation of energy and infrastructure projects, such as transmission lines and liquefied natural gas terminals, could result in noticeably adverse impacts on the area. Also, increased population growth in the surrounding area could lead to an increase in the number of viewers, the frequency and duration of views, and in the perceived impact level.

Cumulative Impacts

The magnitude of cumulative impacts resulting from all general trends taking place within the region in which a storage facility is located would depend on the number of structures affecting the landscape, the degree of contrast, the degree of visibility (which, in turn, depends on the distance and angle from which the landscape is viewed), the value of the landscape, the number of viewers, the frequency and duration of views, and viewer perception of the impact level. The cumulative impacts from general trends and activities would range from minimal (e.g., limited development resulted in minor changes within the viewshed, [NRC 2011c]) to noticeable (e.g., construction of a new power plant or storage would noticeably alter the scenic quality of the area by introducing an industrial presence into a largely undeveloped landscape, see NRC 2011a and 2001a).

6.4.13.2 Potential Cumulative Impacts from Other NRC-Regulated or Spent Fuel-Related Activities

Cumulative impacts on aesthetic resources could result from other NRC-regulated or spent fuel-related activities, such as changes to operational characteristics of the facility (e.g., the condensation plume from a cooling tower) during shutdown and dismantlement, demolition, and removal of structures during decommissioning could have direct aesthetic impacts. Aesthetic impacts from the removal of structures would be a long-term change, and are generally considered beneficial to the visual appeal of a site.

In the Decommissioning GEIS for power reactors (including spent fuel pools), the NRC (2002) determined that the impacts on aesthetic resources during decommissioning would be SMALL and that any impact would be temporary and would serve to reduce the aesthetic impact of the site. The impacts from decommissioning ISFSIs were not considered in the Decommissioning GEIS. Aesthetic impacts from decommissioning the smaller structure of an ISFSI would be no greater than that for decommissioning a nuclear power plant because of the smaller size of the ISFSI. The NRC's EAs for the Calvert Cliffs, Surry, and Diablo Canyon ISFSIs, and the PFSF ISFSI EIS did not identify any significant impacts on aesthetic resources during decommissioning of an at-reactor or away-from-reactor ISFSI (NRC 2001a, 2003, 2005a, 2012b). The NRC assumes that the types and magnitude of impacts from decommissioning an ISFSI at other sites would be similar to that described in the Calvert Cliffs, Surry, and Diablo Canyon EAs and the PFSF EIS because the activities that take place during decommissioning and the change in visual characteristics that would occur at other sites would be similar to those evaluated in the Calvert Cliffs, Surry, and Diablo Canyon EAs and the PFSF EIS.

Given that the impacts from decommissioning reactors, spent fuel pools, and ISFSIs would be similar to the impacts described in the Decommissioning GEIS for reactors and site-specific ISFSI EAs and EISs, impacts on aesthetic resources from decommissioning are expected to be minimal and any impact would be temporary.

6.4.13.3 Conclusions

Cumulative impacts on aesthetic resources include the incremental effects from continued storage when added to the aggregate effects of other past, present, and reasonably foreseeable future actions. As described in Sections 4.14 and 5.14, the incremental impacts from continued storage on aesthetic resources is SMALL for all timeframes for at-reactor storage facilities and SMALL to MODERATE for away-from-reactor storage facilities. In addition, past, present, and reasonably foreseeable activities take place in the geographic area of interest that could contribute to cumulative effects to aesthetic resources. The cumulative impacts from continued storage and other past, present, and reasonably foreseeable Federal and non-Federal activities range from SMALL to MODERATE depending on the incremental impact from the storage facility and the conditions and activities surrounding the site. A SMALL impact would occur at sites where storage facilities have minimal impacts on the viewshed and no other actions occur that had overlapping, noticeable effects on aesthetic resources. A MODERATE impact would occur if the storage facility has a noticeable impact on the viewshed, or if other Federal or non-Federal actions, such as the construction and operation of other nearby power plants or future urbanization, had overlapping impacts with the continued storage of waste that noticeably altered aesthetic resources. At storage facilities where the incremental impacts are SMALL and cumulative impacts are MODERATE from other Federal or non-Federal activities, the NRC determined that the cumulative impacts would likely remain MODERATE whether or not continued storage occurred because the incremental impacts from continued storage would be minor, especially in comparison to other general trends, such as constructing new power plants.

6.4.14 Waste Management

This section evaluates the effects of continued storage on the capacity and operating lifespan of waste-management facilities when added to the aggregate effects of other past, present, and reasonably foreseeable future actions. The incremental impacts from continued storage on waste management are described in Sections 4.15 and 5.15 and summarized in Table 6-3. In addition to the incremental impacts from continued storage, this cumulative impacts analysis also considers other past, present, and reasonably foreseeable projects that could affect waste management. The geographic area considered in the cumulative LLW and mixed-waste-management resources analysis includes the continental United States because LLW disposal facilities handle waste generated on a national scale. The geographic area considered in the cumulative nonradioactive waste (i.e., hazardous and nonhazardous wastes) management resources analysis includes the area where the continued storage of spent fuel occurs and nonradioactive waste is sent for disposal.

Cumulative Impacts

Table 6-3. Summary of Incremental Impacts from Continued Storage on Waste Management

Storage Timeframe	At-Reactor Storage (Section 4.15)		Away-From-Reactor Storage (Section 5.15)	
Short-Term	LLW	SMALL	LLW	SMALL
	Mixed Waste	SMALL	Mixed Waste	SMALL
	Nonradioactive ^(a)	SMALL	Nonradioactive ^(a)	SMALL
Long-Term	LLW	SMALL	LLW	SMALL
	Mixed Waste	SMALL	Mixed Waste	SMALL
	Nonradioactive ^(a)	SMALL	Nonradioactive ^(a)	SMALL
Indefinite	LLW	SMALL	LLW	SMALL
	Mixed Waste	SMALL	Mixed Waste	SMALL
	Nonradioactive ^(a)	SMALL to MODERATE	Nonradioactive ^(a)	SMALL to MODERATE

(a) Nonradioactive waste includes hazardous and nonhazardous wastes.

6.4.14.1 Potential Cumulative Impacts from General Trends and Activities

Cumulative impacts on waste management could include reduction in landfill capacity needed for the proper disposal of the total amount of LLW, mixed waste, and nonradioactive waste resulting from all reasonably foreseeable Federal and non-Federal activities. These impacts result from waste-generating activities associated with residential, commercial, industrial, and military development. The potential cumulative impacts associated with the management of each waste type are discussed below.

Low-Level Waste and Mixed Waste

In addition to LLW generated at operating reactors and other uranium fuel cycle facilities, other radioactive waste-generating activities that can occur in the same regions as operating reactors including activities at DOE and U.S. Department of Defense installations as well as industrial facilities and hospitals where radioisotopes are used for industrial or medical purposes (NRC 2013a). These same activities are potential generators of both LLW and mixed waste.

The magnitude of cumulative waste-management impacts resulting from general trends would depend on current radioactive waste-generating activities, generation rates, potential changes in waste-generating activities and rates, and the extent to which these waste generators employ mitigation measures to reduce such impacts. LLW and mixed waste can only be disposed of in a limited number of disposal facilities, as described in Section 3.14. Depending on the locations of the radioactive waste generators and the locations of available treatment and disposal facilities, there could be cumulative impacts resulting from the transportation, treatment, and disposal of radioactive waste (NRC 2013a). The cumulative impacts from general trends and activities would range from minimal (e.g., minor changes in available disposal capacity and limited development of new governmental, industrial, and medical radioactive waste-generating

activities, see NRC 2013a,b) to noticeable (e.g., loss in available disposal capacity and expanded or new governmental, industrial, and medical radioactive waste-generating activities).

Nonradioactive Waste

In addition to nuclear reactor operations, residential, commercial, and industrial activities also generate nonradioactive waste. Nonradioactive waste includes hazardous and nonhazardous wastes and is typically disposed of in local or regional treatment facilities and landfills. Hazardous waste treatment, storage, and disposal facilities or nonhazardous waste landfills are constructed and operated by local or regional units of government or private companies. The facility size or landfill capacity is based on the projected waste disposal needs for the geographic area or region that the facility or landfill serves. Municipal solid waste landfills in the United States typically have capacities ranging from 1,200,000 m³ (1,600,000 yd³) to more than 45,000,000 m³ (59,000,000 yd³) of compacted solid waste (EREF 1999).

The magnitude of cumulative impacts from the management of nonradioactive wastes resulting from all waste-generating actions taking place in the area in which a storage facility is located would likely be minimal (e.g., minor changes in available facility or landfill capacity and limited increase of waste generation by new residential, commercial, and industrial development, see NRC 2013a,b) to noticeable (e.g., minor changes or decrease in available capacity and major increase in waste generation by new residential, commercial, and industrial development).

6.4.14.2 Potential Cumulative Impacts from Other NRC-Regulated or Spent Fuel-Related Activities

Cumulative impacts on waste-management resources could result from other NRC-regulated or spent fuel-related activities, such as decommissioning of a nuclear power plant (including the spent fuel pool), ISFSI, and DTS. These activities would generate LLW, mixed waste, and nonradioactive waste. Although it would not affect nonradioactive waste disposal on a regional level because of the local availability of nonradiological disposal facilities, construction and operation of a repository for spent fuel disposal would contribute additional LLW and mixed waste, adding to the cumulative impacts from LLW and mixed waste disposal on the limited number of treatment and disposal facilities available throughout the United States.

Low-Level Waste and Mixed Waste

The LLW and mixed-waste-management impacts from reactor decommissioning, including a spent fuel pool, would depend on the size of the reactor and pool. The estimated volume of LLW generated by reactor decommissioning ranges from 580 m³ (760 yd³) to 32,800 m³ (42,900 yd³) (NRC 2002). This quantity of LLW would be generated over a period ranging from about 5 to 14 years depending on the decommissioning option undertaken (NRC 2002). A conservative estimate of the LLW generated annually, using the maximum volume of LLW of

Cumulative Impacts

32,800 m³ (42,900 yd³), is 6,560 m³ (8,580 yd³) for a reactor decommissioning lasting 5 years to 2,340 m³ (3,060 yd³) for a reactor decommissioning lasting 14 years. This range of annual quantities of LLW is much larger than the average annual quantity of LLW produced during reactor operation, which is about 300 m³ (392 yd³) for a pressurized water reactor and about 600 m³ (785 yd³) for a boiling water reactor (NRC 2013a). In the License Renewal GEIS, the NRC considered the LLW that would be generated by decommissioning and concluded that there is reasonable assurance that sufficient LLW disposal capacity will be made available when needed for facilities to be decommissioned consistent with NRC requirements (NRC 2013a).

Mixed waste would also be generated at an increased rate during reactor decommissioning relative to reactor operation. The quantity of mixed waste generated during reactor operation is a small fraction of the quantity of LLW (NRC 2013a). Because of similarities in waste-generating activities during reactor operation and decommissioning, the quantity of mixed waste generated during reactor decommissioning is expected to continue to be a small fraction of the quantity of LLW. Despite an increase in the generation rate of mixed waste during decommissioning, the quantity of mixed waste produced is expected to remain small relative to available disposal capacity.

The decommissioning of dry spent fuel storage facilities would also generate LLW and mixed waste. The types and quantities of LLW and mixed waste generated during decommissioning would be similar to facility replacement, as described in Sections 4.15 and 5.15. The NRC has determined, as described in Sections 4.15 and 5.15, that the incremental impacts from the management and disposal of LLW and mixed waste associated with facility replacement would be SMALL for LLW and mixed waste.

The construction and operation of a repository for spent fuel disposal would also generate LLW. The final EIS for the proposed repository at Yucca Mountain, Nevada, projected that 74,000 m³ (97,000 yd³) of LLW would be generated from the construction and operation of that facility (DOE 2008). The period of construction and operation of the proposed repository was estimated to be greater than 100 years. The DOE determined that the environmental impacts from management and disposal of LLW would be SMALL, because the treatment and disposal capacity exceeds the demand created by the quantities of LLW generated. The DOE indicated that no mixed waste would be generated during the construction and operation of the repository (DOE 2008).

The magnitude of cumulative waste-management impacts resulting from management and disposal of LLW and mixed waste generated from decommissioning of nuclear facilities and construction and operation of a repository for spent fuel disposal would depend on current radioactive waste-generating activities and generation rates and potential changes in waste-generating activities and rates. It would also depend on the extent to which these waste generators employ mitigation measures to reduce such impacts. The cumulative impacts from general trends and activities would range from minimal (e.g., minor changes in available

disposal capacity and limited or no increases in other NRC-regulated or spent fuel-related radioactive waste-generating activities,) to noticeable (e.g., loss in available disposal capacity and increases in other NRC-regulated or spent fuel-related activities that produce radioactive waste). Large cumulative waste-management impacts could occur in the unlikely event that available disposal capacity decreases and radioactive waste generation increases as a result of multiple other NRC-regulated or spent fuel-related activities occurring concurrently.

Nonradioactive Waste

The nonradioactive waste-management impacts from reactor decommissioning, including a spent fuel pool, would depend on the size of the reactor and pool. Similar to LLW and mixed waste, reactor decommissioning generates nonradioactive waste at an increased rate relative to operation over a period ranging from about 5 to 14 years, depending on the decommissioning option undertaken. Because the increased waste generation during decommissioning occurs for a relatively short period of time and decommissioned reactors must continue to comply with Federal and State regulations in terms of storage, treatment, and disposal of waste, the NRC determined in the License Renewal GEIS (NRC 2013a) that the cumulative impacts resulting from the management of nonradioactive wastes resulting from all waste-generating actions taking place within the region in which an operating reactor is located would be SMALL.

The decommissioning of dry spent fuel storage facilities would also generate nonradioactive waste, primarily nonhazardous waste. The types and quantities of nonradioactive waste generated during decommissioning would be similar to facility replacement, as described in Sections 4.15 and 5.15. The NRC has determined, as described in Sections 4.15 and 5.15, that the incremental impacts from management and disposal of nonradioactive waste associated with dry storage facility replacement would be SMALL for short-term and long-term storage and SMALL to MODERATE for indefinite storage.

The magnitude of cumulative waste-management impacts resulting from management and disposal of nonradioactive waste generated during decommissioning of nuclear facilities would depend on current nonradioactive waste-generating activities and generation rates, potential changes in waste-generating activities and rates in an area, and the extent to which waste generators in an area employ mitigation measures to reduce such impacts. The cumulative impacts from general trends and activities would range from minimal (e.g., minor changes in available landfill capacity and limited or no increases in other NRC-regulated or spent fuel-related radioactive waste-generating activities,) to noticeable (e.g., loss in available landfill capacity and increases in other NRC-regulated or spent fuel-related activities that produce nonradioactive waste). Large cumulative waste-management impacts could occur in the unlikely event that available landfill capacity decreases and nonradioactive nonhazardous waste generation increases as a result of multiple other NRC-regulated or spent fuel-related activities occurring concurrently.

Cumulative Impacts

6.4.14.3 Conclusion

Cumulative impacts on waste-management resources include the incremental effects from continued storage when added to the aggregate effects of other past, present, and reasonably foreseeable future actions. The incremental impacts from continued storage on waste-management resources are described in Sections 4.15 and 5.15 and summarized in Table 6-3. In addition, past, present, and reasonably foreseeable Federal and non-Federal activities described in Sections 6.3.1 and 6.3.2, spread across the geographic area of interest (national scale), are SMALL to LARGE for LLW and mixed waste because local, regional, or national waste-management resources might experience minor to destabilizing decreases in their capacity. For nonradioactive waste, the cumulative impacts from other past, present, and reasonably foreseeable Federal and non-Federal activities spread across the geographic area of interest (area surrounding an at-reactor or away-from-reactor spent fuel storage facility) would be SMALL to LARGE. A SMALL impact would occur if local, regional, or national waste-management facilities experience no noticeable decreases in their capacity or operating lifespan from continued storage or other Federal or non-Federal activities. A MODERATE impact would occur if local, regional, or national waste-management facilities experience noticeable decreases in their capacity or operating lifespan. A LARGE impact would occur in the unlikely event that available LLW or nonradioactive nonhazardous waste disposal capacity decreases and LLW or nonradioactive nonhazardous waste generation increases as a result of multiple other NRC-regulated or spent fuel-related activities occurring concurrently. The NRC determined that these cumulative impacts (ranging from SMALL to LARGE) could increase as a result of continued storage of spent fuel because the incremental impacts from continued storage would range from minor to noticeable, which could increase a SMALL cumulative impact to a MODERATE cumulative impact or a MODERATE cumulative impact to a LARGE cumulative impact.

6.4.15 Transportation

This section evaluates the effects of continued storage on transportation when added to the aggregate effects of other past, present, and reasonably foreseeable future actions. As described in Sections 4.16 and 5.16, the incremental impacts from continued storage on nonradiological transportation are SMALL for all timeframes at at-reactor facilities and SMALL to MODERATE at away-from-reactor ISFSIs. The radiological transportation impacts for at-reactor and away-from-reactor continued storage activities are SMALL.

The geographic area considered in the cumulative transportation analysis includes the site of the power plant and at-reactor ISFSI, the site of an away-from-reactor ISFSI, and the local, regional, and national transportation networks and populations that use or live along these networks.

6.4.15.1 Potential Cumulative Impacts from General Trends and Activities

Cumulative transportation impacts involve (1) nonradiological impacts, such as increased traffic (e.g., commuting workers and construction materials) and associated increases in accident risks, injuries, and fatalities and (2) radiological impacts, such as radiation doses from the shipment of radioactive materials including unirradiated fuel, spent fuel, and waste materials (NRC 2011a–e, 2012a, 2013a,b). Traffic impacts can accumulate from multiple actions occurring during the same time period (e.g., overlapping construction projects). Principal contributors to localized traffic that could overlap with storage facility construction and operations include the construction of other energy, water, military, or urbanization projects. Radiation dose impacts can accumulate from multiple shipping activities that overlap during the same time period or from single or multiple shipping actions that occur over time on the same routes. Actions involving shipment of radioactive materials for medical, industrial, research, or other energy projects (NRC 2011a,c,d) could also overlap with continued storage radioactive material shipment impacts.

The magnitude of cumulative impacts resulting from general trends taking place within the region in which a storage facility is located would depend on the nature and location of the actions relative to the storage facility transportation activities. For nonradiological transportation impacts, the cumulative impacts from general trends and activities would range from minimal (e.g., no overlap in traffic with any other development project, see cumulative operational traffic impacts in NRC 2011d) to noticeable (e.g., traffic congestion at specific sites and on roads with limited available capacity to accommodate the increased demand from proposed power plant activities, see NRC 2012a). For radiological transportation impacts, the cumulative impacts would likely be minimal based on factors such as low dose, prior generic impact assessment in 10 CFR 51.52 (spent fuel, LLW), updated supplemental analyses addressing unique site-specific plant characteristics, and the low volume of other regional radioactive materials transportation activities that could overlap with continued storage (NRC 2011a–e, 2013d).

6.4.15.2 Potential Cumulative Impacts from Other NRC-Regulated or Spent Fuel-Related Activities

Cumulative impacts on transportation could result from other NRC-regulated or spent fuel-related activities, such as increases in traffic from workers during final reactor shutdown activities; decommissioning of the reactor power block (including the spent fuel pool), ISFSIs, and DTS; and transportation of spent fuel from an at-reactor or away-from-reactor ISFSI to a repository for disposal.

Nonradiological traffic impacts from reactor shutdown activities would result from a temporary increase in the reactor workforce; however, the number of workers would not be expected to exceed the temporary workforce used for refueling outages. Therefore, the traffic impacts during shutdown would be similar to the traffic impacts during reactor operations. Traffic

Cumulative Impacts

impacts during shutdown were evaluated in the License Renewal GEIS in which the NRC (2013a) determined traffic impacts to be SMALL for operating plants. Combined nonradiological and radiological traffic impacts from reactor decommissioning were previously evaluated by the NRC in the Decommissioning GEIS for nuclear reactors (NRC 2002). In that analysis, the NRC evaluated the number of shipments of dismantled equipment, material, and debris from decommissioning. Although the number of shipments can be relatively large, the decommissioning period extends over several years. As a result, the number of LLW shipments per day is low, with an average of less than one shipment per day from the plant (NRC 2002). The materials transported offsite would include all wastes generated onsite. Nonradiological impacts would include increased traffic volume, additional wear and tear on roadways, and potential traffic accidents (NRC 2002). This information supported a conclusion that the transportation impacts from nuclear power plant decommissioning would not be detectable (NRC 2002).

Additional radiological impacts would occur from transportation of (1) spent fuel to a repository for disposal and (2) LLW from decommissioning the reactor, spent fuel pool, and ISFSI. Radiological impacts would include exposure of transportation workers and the general public along the transportation routes. The NRC previously determined that radiological impacts on the public and workers of spent fuel and waste shipments from a reactor are SMALL in several evaluations. For example, the NRC made a generic impact determination in Table S-4 in 10 CFR 51.52 and the supporting analysis (AEC 1972) that the environmental impacts of transportation of fuel and waste to and from a 1,000- to 1,500-MW(e) light water reactor would be SMALL under incident-free and accident conditions. The results of subsequent analyses of transportation impacts in *Final Environmental Statement on Transportation of Radioactive Material by Air and Other Modes* (NRC 1977) and *Reexamination of Spent Fuel Shipment Risk Estimates* (Sprung et al. 2000) confirmed spent fuel transportation impacts are small. Additional site-specific analyses of transportation impacts for power plants that did not meet the conditions of 10 CFR 51.52 also concluded the transportation radiological impacts would be SMALL (NRC 2006, 2008, 2011a-e, 2013c). In the License Renewal GEIS (NRC 2013a), the NRC also concluded that impacts from uranium fuel cycle transportation, including transportation of spent fuel to a repository for disposal, are SMALL for all nuclear plants. More recently, the NRC calculated spent fuel transportation risks for individual shipments in *Spent Fuel Transportation Risk Assessment: Final Report* (NRC 2014) based on current models, data, and assumptions. The analysis modeled responses of transportation packages to accident conditions such as impact force and fire, and calculated risks considering a range of truck and rail accidents of different severities including those involving no release or loss of shielding, loss of shielding only, or loss of shielding and release. That analysis reconfirmed that the radiological impacts from spent fuel transportation conducted in compliance with NRC regulations are low. The NRC also concluded that the regulations for transportation of radioactive material were adequate to protect the public against unreasonable risk (NRC 2014). Based on the generic determination in Table S-4 of 10 CFR 51.52 and the subsequent spent fuel transportation impact analyses

and risk assessments cited above, the NRC concludes the radiological impacts for incident-free and accident transportation of spent fuel from a single at-reactor storage facility to a repository would be small.

Radiological impacts may accumulate along the transportation route for an away-from-reactor ISFSI because the same overall transportation route would be used to transfer the entire inventory of spent fuel from an away-from-reactor ISFSI to a repository. To evaluate these impacts from an away-from-reactor ISFSI, the NRC reviewed other past evaluations of transportation of spent fuel from an away-from-reactor ISFSI to a repository. For example, the NRC previously evaluated the radiological and nonradiological impacts from a comparable (full inventory) transportation scenario for PFSF and concluded that the impacts would be SMALL (NRC 2001a). That analysis calculated incident-free and accident risks from 4,000 shipments of spent fuel from Maine to Utah over a 20-year period. The resulting cumulative dose to the maximally exposed individual (an individual that is assumed for the purpose of performing a bounding analysis of incident-free transportation to be exposed to the radiation from all shipments) at the end of the 20-year period was 0.022 mSv (2.2 mrem). For comparison, the annual NRC public dose limit in 10 CFR Part 20 is 1 mSv (100 mrem). The NRC (2001a) also concluded that the radiological impacts from transportation of a single reactor's spent fuel from an away-from-reactor ISFSI to a repository would be bounded by, or comparable to, impacts evaluated in Table S-4 in 10 CFR 51.52. Based on these analyses, the NRC concludes that the additional accumulated impacts from transportation of the entire inventory of spent fuel from an away-from-reactor ISFSI to a repository would be minor.

6.4.15.3 Conclusion

Cumulative impacts on transportation include the incremental effects from continued storage when added to the aggregate effects of other past, present, and reasonably foreseeable future actions. As described in Sections 4.16 and 5.16, the incremental impacts from continued storage on transportation is SMALL for all timeframes at an at-reactor ISFSI and SMALL to MODERATE for all timeframes at an away-from-reactor ISFSI. In addition, past, present, and reasonably foreseeable activities take place in the geographic area of interest that could contribute to cumulative effects to transportation. The cumulative impacts from continued storage when added to other past, present, and reasonably foreseeable Federal and non-Federal activities (such as construction of energy, water, military, or urbanization projects) would range from SMALL to MODERATE for nonradiological transportation and SMALL for radiological transportation.

6.4.16 Public and Occupational Health

This section evaluates the effects of continued storage on public and occupational health when added to the aggregate effects of other past, present, and reasonably foreseeable future actions. As described in Sections 4.17 and 5.17, the incremental impacts from continued

Cumulative Impacts

storage on public and occupational health are SMALL for all timeframes at both at-reactor and away-from-reactor storage facilities.

For this analysis, the geographic area considered in the cumulative public and occupational health resources analysis is the area within an 80-km (50-mi) radius of the at-reactor or away-from-reactor storage facility site. Historically, the NRC has used the 80-km (50-mi) radius as a standard geographic area to evaluate population doses from routine releases from nuclear power plants. The 80-km (50-mi) radius was selected to encompass potential impact overlaps from two or more nuclear facilities. This concept is discussed in detail in the site-specific EISs for new reactors and ISFSI EAs or EISs reviewed for this GEIS analysis (see e.g., NRC 2011d, Section 6.8).

6.4.16.1 Potential Cumulative Impacts from General Trends and Activities

Cumulative human health impacts relate to public exposure to radiological, chemical, and microbiological hazards and the potentially chronic effects of electromagnetic field (EMF) exposure. Public exposures may occur as a result of environmental accumulations of harmful constituents released from various facilities associated with urban, agricultural, industrial, and commercial development. The potential cumulative impacts of EMF exposure, while uncertain, would relate to activities (e.g., transmission lines and substations) associated with urban, industrial, and commercial development. The NRC acknowledges that there is no conclusive link between EMF exposure and human health impacts (NRC 2013a).

The magnitude of cumulative impacts resulting from general trends taking place within the region in which a storage facility is located would depend on the nature and location of the actions, the number of actions (facilities or projects), the level of the public's exposure, and whether facilities comply with regulating agency requirements (e.g., permitted discharge limits). For public and occupational health, the cumulative impact would be minimal (e.g., NRC 2011a–e, 2012a, 2013a–c) because reactors and other industrial buildings would be required to meet regulations such as the Occupational Safety and Health Administration's General Industry Standards (29 CFR Part 1910) and Construction Industry Standards (29 CFR Part 1926) and, as applicable, operated under NRC regulations such as 10 CFR Part 72 and 10 CFR Part 20. For example, even though increased urbanization might suggest an increased public exposure because of a larger receptor group, the NRC would still require the regulated nuclear facilities in the area of interest to prove through monitoring and as low as is reasonably achievable (ALARA) programs that they were meeting the public and occupational health regulations.

6.4.16.2 Potential Cumulative Impacts from Other NRC-Regulated or Spent Fuel-Related Activities

Cumulative impacts on public and occupational health could result from other NRC-regulated or spent fuel-related activities, such as reactor plant shutdown activities prior to decommissioning, decommissioning activities, construction of infrastructure to support away-from-reactor ISFSIs, and preparation activities to enable transportation of waste to a repository. The NRC has evaluated environmental impacts from these activities in the Decommissioning GEIS (NRC 2002) for reactor decommissioning and the PFSF EIS (NRC 2001a) for ISFSI decommissioning and found the public and occupational health impacts to be SMALL. The NRC also evaluated environmental impacts from infrastructure to support away-from-reactor ISFSIs in the PFSF EIS (NRC 2001a) and found the public and occupational health impacts to be SMALL. For activities related to spent fuel transportation to a repository, such as spent fuel storage maintenance activities that involve bare fuel handling in a postulated DTS at nearby facilities, as noted in Sections 4.17 and 5.17, the public and occupational health impacts would be SMALL and would not aggregate to more significant impacts, given the limited number of facilities within 80 km (50 mi) expected to be in the decommissioning phase of their lifecycle.

6.4.16.3 Conclusion

Cumulative impacts on public and occupational health include the incremental effects from continued storage when added to the aggregate effects of other past, present, and reasonably foreseeable future actions. As described in Sections 4.17 and 5.17, the incremental impacts from continued storage on public and occupational health is SMALL for all timeframes at both at-reactor and away-from-reactor storage facilities. The cumulative impacts from continued storage when added to other past, present, and reasonably foreseeable Federal and non-Federal activities are expected to be SMALL because storage facilities, reactors, and other proposed industrial buildings would be required to meet regulations such as the Occupational Safety and Health Administration's General Industry Standards (29 CFR Part 1910) and Construction Industry Standards (29 CFR Part 1926) and, as applicable, operated under NRC regulations such as 10 CFR Part 72 and 10 CFR Part 20.

6.4.17 Environmental Impacts of Postulated Accidents

This section evaluates the effects of continued storage on accident risk when added to the aggregate effects of other past, present, and reasonably foreseeable future actions. As described in Sections 4.18 and 5.18, the incremental impacts from continued storage on environmental impacts of postulated accidents is SMALL for all timeframes at both at-reactor and away-from-reactor storage facilities.

The geographic area considered in the cumulative accident risk assessment is an 80-km (50-mi) radius from an at-reactor or away-from-reactor storage facility. The cumulative analysis

Cumulative Impacts

considers risk from potential accidents from other nuclear plants or storage facilities that have the potential to increase risks at any location within 80 km (50 mi) of the shutdown reactor or storage facility. It is possible that one or more other types of nuclear facilities that support the nuclear fuel cycle may be located within an 80-km (50-mi) radius, but these facilities generally involve very low accident risk (51 FR 30028). Therefore, the analysis below focuses on the cumulative risk from reactors and storage facilities.

6.4.17.1 Potential Cumulative Impacts from General Trends and Activities

Based on a review of the other activities that can occur near proposed new at-reactor storage facilities, there are two scales of cumulative impacts on accident risk, including (1) cumulative impacts due to the various impacts from an individual power plant and storage facility over time (e.g., annual design basis and severe accident risks at a reactor), and (2) cumulative impacts due to closely sited operating or decommissioning reactors (e.g., design basis and severe accident risks at other reactors located within 80 km [50-mi]) or other radioactive facilities. In addition, climate change can impact accident risk due to higher or lower intensity or frequency of natural phenomena hazards (e.g., precipitation, tornadoes, hurricanes) that could result in radiological accidents.

The magnitude of cumulative accident impacts resulting from all general trends taking place within the 80-km (50-mi) region of a power plant and storage facility would likely be limited because:

1. Estimates of average individual early fatality and latent cancer fatality risks are well below the Commission's safety goals at all plants (51 FR 30028).
2. The Commission has determined that the probability-weighted consequences of severe accidents of a nuclear power plant are SMALL (10 CFR Part 51, Appendix B, Table B-1).
3. The severe accident risk due to any particular nuclear power plant gets smaller as the distance from that plant increases. However, the combined risk at any location within 80 km (50 mi) of a reactor site would be bounded by the sum of risks for all of these operating and proposed nuclear power plants. Even though several plants and other nuclear facilities could potentially be included in the combination, this combined risk would still be low.

Because design basis accidents at nearby power plants and storage facilities are individually unlikely to occur more than once over the life of a facility, and licensees must show that accident consequences of design basis accidents are mitigated to acceptable levels of dose offsite, the cumulative impact of design basis accidents is very small. Based on the above discussion, the NRC concluded that, in all new reactor EISs published through February 2013 (e.g., NRC 2011a–e, 2013c), the cumulative risks from design basis and severe accidents at any location within 80 km (50 mi) of a reactor would be SMALL.

Potential cumulative impacts from an at-reactor ISFSI or an away-from-reactor ISFSI would be minimal because of passive nature of the ISFSI; there is no routine release of gaseous or liquid radiological effluents during operation. In addition, because licensees are required to maintain doses as low as is reasonably achievable in accordance with NRC radiation protection regulations, both an ISFSI and an away-from-reactor facility are designed to minimize radiological doses to workers and public. Additionally, the severe accident risk from a spent fuel storage facility also decreases as the distance from that facility increases. On this basis, the NRC concluded that the cumulative risk of continued storage from design basis and severe accidents at an ISFSI or an away-from-reactor storage facility would be SMALL.

6.4.17.2 Potential Cumulative Impacts from Other NRC-Regulated or Spent Fuel-Related Activities

Cumulative impacts of postulated accidents could result from other NRC-regulated or spent fuel-related activities, such as spent fuel storage maintenance activities. Activities that involve bare fuel handling in a postulated dry transfer facility at nearby facilities could involve additional accident risk. However, as noted in Sections 4.18 and 5.18, these impacts would be SMALL, and would not aggregate to more significant impacts, given the limited number of facilities within 80 km (50 mi) expected to be in this part of their life cycle.

Before spent fuel storage facilities can begin final decommissioning and license termination, the spent fuel must be removed from the site and stored or disposed of offsite. Once the spent fuel is removed from the site, the residual radioactive material at a reactor poses very little accident risk. Therefore, impacts on accident risk from decommissioning are expected to be SMALL (NRC 2002).

6.4.17.3 Conclusion

Cumulative impacts of postulated accidents include the incremental effects from continued storage when added to the aggregate effects of other past, present, and reasonably foreseeable future actions. As described in Sections 4.18 and 5.18, the incremental impacts from continued storage on environmental impacts of postulated accidents is SMALL for all timeframes at both at-reactor and away-from-reactor storage facilities. In addition, past, present, and reasonably foreseeable activities take place in the geographic area of interest that could contribute to cumulative effects to accident risk.

The NRC determined that the cumulative impacts from a reactor, a spent fuel pool, and an ISFSI would be minimal because accident risk remains SMALL. The cumulative impacts from other past, present, and reasonably foreseeable Federal and non-Federal activities described in Sections 6.3.1 and 6.3.2 are SMALL. Given that estimates of average individual early fatality and latent cancer fatality risks are well below the Commission's safety goals at all nuclear power plants (51 FR 30028), the Commission determination that the probability-weighted

Cumulative Impacts

consequences of severe accidents of a nuclear power plant are SMALL (10 CFR Part 51, Appendix B, Table B-1), and that the combined risk from several plants and other nuclear facilities would be low, the NRC concludes that the cumulative impacts at all storage sites would be SMALL.

6.5 Summary

The impact levels determined by the NRC in the previous chapters from at-reactor storage (Chapter 4), away-from-reactor storage (Chapter 5), and cumulative impacts from continued storage when added to other past, present, and reasonably foreseeable activities (Chapter 6) are summarized in Table 6-4. The impact levels are denoted as SMALL, MODERATE, and LARGE as a measure of their expected adverse environmental impacts. For some resource areas, the impact determination language is specific to the authorizing regulation, executive order, or guidance. Impact determinations that include a range of impacts reflect uncertainty related to both geographic variability and the temporal scale of the analysis. As a result, based on analyses performed in this GEIS, the NRC expects that further site-specific analysis would be unlikely to result in impact conclusions with different ranges.

Table 6-4. Summary of the Cumulative Impacts from Continued Storage When Added to Other Federal and Non-Federal Activities

Resource Area	Incremental Impact from At-Reactor Storage	Incremental Impact from Away-From-Reactor Storage	Cumulative Impact from Continued Storage and other Federal and Non-Federal Activities
Land Use	SMALL	SMALL	SMALL to MODERATE
Socioeconomics	SMALL	SMALL (adverse) to LARGE (beneficial)	SMALL to LARGE
Environmental Justice	Disproportionately high and adverse impacts are not expected		
Air Quality	SMALL	SMALL to MODERATE	SMALL to MODERATE
Climate Change	SMALL	SMALL	MODERATE
Geology and Soils	SMALL	SMALL	SMALL to MODERATE
Surface-Water Quality and Use	SMALL	SMALL	SMALL to LARGE
Groundwater Quality and Use	SMALL	SMALL	SMALL to LARGE
Terrestrial Resources ^(a)	SMALL	SMALL to MODERATE	SMALL to MODERATE
Aquatic Ecology ^(a)	SMALL	SMALL	SMALL to LARGE
Historic and Cultural Resources	SMALL to LARGE	SMALL to LARGE	SMALL to LARGE
Noise	SMALL	SMALL	SMALL to MODERATE
Aesthetics	SMALL	SMALL to MODERATE	SMALL to MODERATE
Waste Management	SMALL to MODERATE	SMALL to MODERATE	SMALL to LARGE

Table 6-4. Summary of the Cumulative Impacts from Continued Storage When Added to Other Federal and Non-Federal Activities (cont'd)

Resource Area	Incremental Impact from At-Reactor Storage	Incremental Impact from Away-From-Reactor Storage	Cumulative Impact from Continued Storage and other Federal and Non-Federal Activities
Transportation	SMALL	SMALL to MODERATE	SMALL to MODERATE
Public and Occupational Health	SMALL	SMALL	SMALL
Accidents	SMALL	SMALL	SMALL

(a) Cumulative impacts for Federally listed threatened and endangered species and Essential Fish Habitat would be determined as part of consultations for the Endangered Species Act and the Magnuson–Stevens Fishery Conservation and Management Act.

6.6 References

10 CFR Part 20. *Code of Federal Regulations*, Title 10, *Energy*, Part 20, “Standards for Protection Against Radiation.” Washington, D.C.

10 CFR Part 50. *Code of Federal Regulations*, Title 10, *Energy*, Part 50, “Domestic Licensing of Production and Utilization Facilities.” Washington, D.C.

10 CFR Part 51. *Code of Federal Regulations*, Title 10, *Energy*, Part 51, “Environmental Protection Regulations for Domestic Licensing and Related Regulatory Functions.” Washington, D.C.

10 CFR Part 52. *Code of Federal Regulations*, Title 10, *Energy*, Part 52, “Licenses, Certifications, and Approvals for Nuclear Power Plants.” Washington, D.C.

10 CFR Part 71. *Code of Federal Regulations*, Title 10, *Energy*, Part 71, “Packaging and Transportation of Radioactive Material.” Washington, D.C.

10 CFR Part 72. *Code of Federal Regulations*, Title 10, *Energy*, Part 72, “Licensing Requirements for the Independent Storage of Spent Nuclear Fuel, High-Level Radioactive Waste, and Reactor-Related Greater Than Class C Waste.” Washington, D.C.

29 CFR Part 1910. *Code of Federal Regulations*, Title 29, *Standards*, Part 1910, “Occupational Safety and Health Standards.” Washington, D.C.

29 CFR Part 1926. *Code of Federal Regulations*, Title 29, *Standards*, Part 1926, “Safety and Health Regulations for Construction.” Washington, D.C.

Cumulative Impacts

40 CFR Part 1508. *Code of Federal Regulations*, Title 40, *Protection of Environment*, Part 1508, “Terminology and Index.” Washington, D.C.

49 CFR Parts 171–180. *Code of Federal Regulations*, Title 49, *Transportation*, Parts 171–180, “Hazardous Materials Regulations.” Washington, D.C.

50 CFR Part 402. *Code of Federal Regulations*, Title 50, *Wildlife and Fisheries*, Part 402, “Interagency Cooperation—Endangered Species Act of 1973, as Amended.” Washington, D.C.

51 FR 30028. August 21, 1986. “Safety Goals for the Operations of Nuclear Power Plants; Policy Statement; Republication.” *Federal Register*, U.S. Nuclear Regulatory Commission, Washington, D.C.

69 FR 52040. August 24, 2004. “Policy Statement on the Treatment of Environmental Justice Matters in NRC Regulatory and Licensing Actions.” *Federal Register*, U.S. Nuclear Regulatory Commission, Washington, D.C.

74 FR 66496. December 15, 2009. “Endangerment and Cause or Contribute Findings for Greenhouse Gases Under Section 202(a) of the Clean Air Act.” *Federal Register*, U.S. Environmental Protection Agency, Washington, D.C.

75 FR 31514. June 3, 2010. “Prevention of Significant Deterioration and Title V Greenhouse Gas Tailoring Rule.” *Federal Register*, U.S. Environmental Protection Agency, Washington, D.C.

78 FR 19537. April 1, 2013. “SHINE Medical Technologies, Inc.; Exemption.” *Federal Register*, U.S. Nuclear Regulatory Commission, Washington, D.C.

78 FR 21919. April 12, 2013. “Finding of No Significant Impact and Final Programmatic Environmental Assessment for Army 2020 Force Structure Realignment.” *Federal Register*, U.S. Department of the Army, Washington, D.C.

AEC (U.S. Atomic Energy Commission). 1972. *Environmental Survey of Transportation of Radioactive Materials to and From Nuclear Power Plants*. WASH-1238, Washington, D.C. Available at http://www.osti.gov/energycitations/product.biblio.jsp?osti_id=4569134.

BRC (Blue Ribbon Commission on America’s Nuclear Future). 2012. “Report to the Secretary of Energy.” Washington, D.C. Accession No. ML120970375.

Clean Water Act (See Federal Water Pollution Control Act of 1972).

CEQ (Council on Environmental Quality). 1997. *Considering Cumulative Effects under the National Environmental Policy Act*. Washington, D.C. Accession No. ML12243A349.

- CEQ (Council on Environmental Quality). 2003. *The NEPA Task Force Report to the Council on Environmental Quality—Modernizing NEPA Implementation*. Washington, D.C. Accession No. ML100840639.
- CEQ (Council on Environmental Quality). 2010. *Draft NEPA Guidance on Consideration of the Effects of Climate Change and Greenhouse Gas Emissions*. Washington, D.C. Accession No. ML12221A314.
- CYAPC (Connecticut Yankee Atomic Power Company). 2012. *Haddam Neck Plant Independent Spent Fuel Storage Installation Decommissioning Study*. East Hampton, Connecticut. Accession No. ML123630241.
- DOE (U.S. Department of Energy). 1996. *Dry Transfer System Topical Safety Analysis Report*. Volume 1, Washington, D.C. Accession No. ML052220472.
- DOE (U.S. Department of Energy). 2008. *Final Supplemental Environmental Impact Statement for a Geologic Repository for the Disposal of Spent Nuclear Fuel and High-Level Radioactive Waste at Yucca Mountain, Nye County, Nevada*. DOE EIS-0250F-S1, Office of Civilian Radioactive Waste Management, Las Vegas, Nevada. Accession No. ML081750212.
- DOE (U.S. Department of Energy). 2013. *Strategy for the Management and Disposal of Used Nuclear Fuel and High-Level Radioactive Waste*. Washington, D.C. Accession No. ML13011A138.
- Endangered Species Act of 1973 (ESA), as amended. 16 USC 1531 *et seq.*
- EIA (Energy Information Administration). 2011. *Electric Power Annual 2010*. Washington, D.C. Available at <http://www.eia.gov/electricity/annual/archive/03482010.pdf>.
- EIA (Energy Information Administration). 2012a. *Annual Energy Outlook 2013 Early Release Overview*. Washington, D.C. Available at <http://www.eia.gov/forecasts/archive/aeo13/er/>.
- EIA (Energy Information Administration). 2012b. *Annual Energy Outlook 2012 With Projections to 2035*. DOE/EIA-0383(2012), Washington, D.C. Available at [http://www.eia.gov/forecasts/aeo/pdf/0383\(2012\).pdf](http://www.eia.gov/forecasts/aeo/pdf/0383(2012).pdf).
- EIA (Energy Information Administration). 2012c. *Number and Capacity of Petroleum Refineries*. Washington, D.C. Available at http://www.eia.gov/dnav/pet/pet_pnp_cap1_dcu_nus_a.htm.
- EIA (Energy Information Administration). 2012d. *2011 Uranium Marketing Annual Report*. Washington, D.C. Available at <http://www.eia.gov/uranium/marketing/pdf/2011umar.pdf>.

Cumulative Impacts

EPA (U.S. Environmental Protection Agency). 1999. *Consideration of Cumulative Impacts in EPA Review of NEPA Documents*. EPA 315–R–99–002, Washington, D.C. Accession No. ML040081036.

EPA (U.S. Environmental Protection Agency). 2013a. *Inventory of U.S. Greenhouse Gas Emissions and Sinks: 1990–2011*. EPA 430-R-13-001, Washington, D.C. Accession No. ML13331A473.

EPA (U.S. Environmental Protection Agency). 2013b. *Clean Energy: Calculations and References*. Washington, D.C. Accession No. ML13205A377.

EREF (Environmental Research and Education Foundation). 1999. *Lifecycle Inventory of a Modern Municipal Solid Waste Landfill*. Washington, D.C. Available at <http://erefdn.org/publications/uploads/LifeCycleInvRep.pdf>.

Federal Water Pollution Control Act of 1972, as amended (also referred to as the Clean Water Act). 33 USC 1251 *et seq.*

GCRP (U.S. Global Change Research Program). 2014. *Highlights of Climate Change Impacts in the United States: The Third National Climate Assessment*. J.M. Melillo, T.C. Richmond, and G.W. Yohe, eds. U.S. Government Printing Office, Washington, D.C. Accession No. ML14129A233.

INGAA (Interstate Natural Gas Association of America). 2011. *North American Midstream Infrastructure Through 2035—A Secure Energy Future*. Washington, D.C. Available at <http://www.ingaa.org/File.aspx?id=14900>.

Magnuson–Stevens Fishery Conservation and Management Act of 1976, as amended. 16 USC 1801 *et seq.*

MYAPC (Maine Yankee Atomic Power Company). 2013. *Maine Yankee Independent Spent Fuel Storage Installation Decommissioning Funding Plan*. Wiscasset, Maine. Accession No. ML130460347.

National Environmental Policy Act of 1969 (NEPA), as amended. USC 4321 *et seq.*

National Historic Preservation Act (NHPA), as amended. 16 USC 470 *et seq.*

National Research Council. 2009. *Driving and the Built Environment: The Effects of Compact Development on Motorized Travel, Energy Use, and CO₂ Emissions*. Special Report 298, Washington, D.C. Available at <http://onlinepubs.trb.org/Onlinepubs/sr/sr298.pdf>.

NPC (National Petroleum Council). 2007. *Topic Paper #16: Refining and Manufacturing*. Washington, D.C. Available at http://www.npc.org/Study_Topic_Papers/16-STG-RefiningManu.pdf.

NPC (National Petroleum Council). 2011. *Paper #1.9: Natural Gas Infrastructure*. Washington, D.C.

NPSCC (National Parks Second Century Commission). 2009. *Advancing the National Park Idea: National Parks Second Century Commission Report*. Washington, D.C. Available at http://www.npcca.org/assets/pdf/Commission_Report.PDF.

NRC (U.S. Nuclear Regulatory Commission). 1977. *Final Environmental Statement on Transportation of Radioactive Material by Air and Other Modes*. NUREG-0170, Volume 1, Washington, D.C. Accession Nos. ML022590265, ML022590348.

NRC (U.S. Nuclear Regulatory Commission). 2000. *Consolidated Guidance About Materials Licenses: Guidance About Administrative Licensing Procedures*. NUREG-1556, Volume 20, Washington, D.C. Accession No. ML022830863.

NRC (U.S. Nuclear Regulatory Commission). 2001a. *Final Environmental Impact Statement for the Construction and Operation of an Independent Spent Fuel Storage Installation on the Reservation of the Skull Valley Band of Goshute Indians and the Related Transportation Facility in Tooele County, Utah*. NUREG-1714, Volume 1, Washington, D.C. Accession No. ML020150170.

NRC (U.S. Nuclear Regulatory Commission). 2001b. *Technical Study of Spent Nuclear Fuel Pool Accident Risk at Decommissioning Nuclear Power Plants*. NUREG-1738, Washington, D.C. Accession No. ML010430066.

NRC (U.S. Nuclear Regulatory Commission). 2002. *Final Generic Environmental Impact Statement on Decommissioning of Nuclear Facilities, Supplement 1 Regarding the Decommissioning of Nuclear Power Reactors*. NUREG-0586, Volume 1, Washington, D.C. Accession Nos. ML023470327, ML023500228.

NRC (U.S. Nuclear Regulatory Commission). 2003. *Environmental Assessment Related to the Construction and Operation of the Diablo Canyon Independent Spent Fuel Storage Installation*. Washington, D.C. Accession No. ML032970370.

NRC (U.S. Nuclear Regulatory Commission). 2005a. *Environmental Assessment Related to the Renewal of the License for the Surry Independent Spent Fuel Storage Installation*. Washington, D.C. Accession No. ML040560238.

Cumulative Impacts

NRC (U.S. Nuclear Regulatory Commission). 2005b. *Environmental Assessment Related to the Renewal of the H.B. Robinson Steam Electric Plant, Unit No. 2 Independent Spent Fuel Storage Installation License Special Nuclear Materials License No. SNM-2502*.

Washington, D.C. Accession No. ML050700137.

NRC (U.S. Nuclear Regulatory Commission). 2005c. *Environmental Assessment Related to the Construction and Operation of the Humboldt Bay Independent Spent Fuel Storage Installation*. Washington, D.C. Accession No. ML052430106.

NRC (U.S. Nuclear Regulatory Commission). 2005d. *Generic Environmental Impact Statement for License Renewal of Nuclear Plants, Supplement 23 Regarding Point Beach Nuclear Plant Units 1 and 2*. NUREG-1437, Supplement 23, Washington, D.C. Accession No. ML052230490.

NRC (U.S. Nuclear Regulatory Commission). 2006. *Final Environmental Statement for an Early Site Permit (ESP) at the North Anna ESP Site*. NUREG-1811, Volume 1, Washington, D.C. Accession No. ML063470330.

NRC (U.S. Nuclear Regulatory Commission). 2008. *Final Environmental Statement for an Early Site Permit (ESP) at the Vogtle Electric Generating Plant Site*. NUREG-1872, Volume 1, Washington, D.C. Accession No. ML082240145.

NRC (U.S. Nuclear Regulatory Commission). 2009. *Environmental Assessment for the Renewal of U.S. Nuclear Regulatory Commission License No. SNM-2503 for Oconee Nuclear Power Station Independent Spent Fuel Storage Installation*. Washington, D.C. Accession No. ML091340557.

NRC (U.S. Nuclear Regulatory Commission). 2011a. *Final Environmental Impact Statement for Combined Licenses (COLs) for South Texas Project Electric Generating Station Units 3 and 4*. NUREG-1937, Washington, D.C. Accession No. ML11049A000.

NRC (U.S. Nuclear Regulatory Commission). 2011b. *Final Supplemental Environmental Impact Statement for Combined Licenses (COLs) for Vogtle Electric Generating Plant Units 3 and 4*. NUREG-1947, Washington, D.C. Accession No. ML11076A010.

NRC (U.S. Nuclear Regulatory Commission). 2011c. *Final Environmental Impact Statement for Combined Licenses (COLs) for Virgil C. Summer Nuclear Station, Units 2 and 3*. NUREG-1939, Volumes 1 and 2, Washington, D.C. Accession Nos. ML11098A044, ML11098A057.

NRC (U.S. Nuclear Regulatory Commission). 2011d. *Final Environmental Impact Statement for Combined Licenses for Calvert Cliffs Nuclear Power Plant Unit 3*. NUREG-1936, Volumes 1 and 2, Washington, D.C. Accession Nos. ML11129A167, ML11129A179.

NRC (U.S. Nuclear Regulatory Commission). 2011e. *Final Environmental Impact Statement for Combined Licenses for Comanche Peak Nuclear Power Plant Units 3 and 4*. NUREG–1943, Volumes 1 and 2, Washington, D.C. Accession Nos. ML11131A001, ML11131A002.

NRC (U.S. Nuclear Regulatory Commission). 2011f. *Generic Environmental Impact Statement for License Renewal of Nuclear Plants, Supplement 44 Regarding Crystal River Unit 3 Nuclear Generating Plant—Draft Report for Comment*. NUREG–1437, Supplement 44, Washington, D.C. Accession No. ML11139A153.

NRC (U.S. Nuclear Regulatory Commission). 2011g. *Generic Environmental Impact Statement for License Renewal of Nuclear Plants, Supplement 46 Regarding Seabrook Station—Draft Report for Comment*. NUREG–1437, Supplement 46, Washington, D.C. Accession No. ML11213A080.

NRC (U.S. Nuclear Regulatory Commission). 2012a. *Final Environmental Impact Statement for Combined Licenses for Levy Nuclear Plant Units 1 and 2*. NUREG–1941, Volumes 1 and 2, Washington, D.C. Accession Nos. ML12100A063, ML12320A105.

NRC (U.S. Nuclear Regulatory Commission). 2012b. *Environmental Assessment for the Proposed Renewal of U.S. Nuclear Regulatory Commission License No. SNM–2505 for Calvert Cliffs Nuclear Power Plant, LLC’s Independent Spent Fuel Storage Installation*. Washington, D.C. Accession No. ML121220084.

NRC (U.S. Nuclear Regulatory Commission). 2012c. *Generic Environmental Impact Statement for License Renewal of Nuclear Plants, Supplement 47 Regarding Columbia Generating Station*. NUREG–1437, Supplement 47, Washington, D.C. Accession No. ML12096A334.

NRC (U.S. Nuclear Regulatory Commission). 2013a. *Generic Environmental Impact Statement for License Renewal of Nuclear Plants*. NUREG–1437, Revision 1, Washington, D.C. Accession No. ML13107A023.

NRC (U.S. Nuclear Regulatory Commission). 2013b. *Environmental Impact Statement for the Combined License (COL) for Enrico Fermi Unit*. NUREG–2105, Volumes 1 and 2, Washington, D.C. Accession Nos. ML12307A172, ML12307A176.

NRC (U.S. Nuclear Regulatory Commission). 2013c. *Final Environmental Impact Statement for Combined Licenses for William States Lee III Nuclear Station Units 1 and 2*. NUREG–2111, Volumes 1 and 2, Washington, D.C. Accession Nos. ML13340A005, ML13340A006, ML13340A007.

NRC (U.S. Nuclear Regulatory Commission). 2013d. *Spent Fuel Storage in Pools and Dry Casks Key Points and Questions and Answers*. Washington, D.C. Accession No. ML120970230.

Cumulative Impacts

NRC (U.S. Nuclear Regulatory Commission). 2013e. *2013–2014 Information Digest*. NUREG–1350, Volume 25, Washington, D.C. Available at <http://www.nrc.gov/reading-rm/doc-collections/nuregs/staff/sr1350/v25/sr1350v25.pdf>.

NRC (U.S. Nuclear Regulatory Commission). 2013f. *Attachment 1—Staff Guidance for Greenhouse Gas and Climate Change Impacts for New Reactor Environmental Impact Statements*. COL/ESP-ISG-026, Washington, D.C. Accession No. ML12326A811.

NRC (U.S. Nuclear Regulatory Commission). 2014. *Spent Fuel Transportation Risk Assessment Final Report*. NUREG–2125, Washington, D.C. Accession No. ML14031A323.

Nuclear Waste Policy Act of 1982 (NWPA), as amended. 42 USC 10101, *et seq.*

Pitkin, J. and D. Myers. 2008. *U.S. Housing Trends: Generational Changes and the Outlook to 2050*. Special Report 298, National Research Council, Washington, D.C. Available at <http://onlinepubs.trb.org/Onlinepubs/sr/sr298pitkin-myers.pdf>.

Sprung, J.L., D.J. Ammerman, N.L. Breivik, R.J. Dukart, F.L. Kanipe, J.A. Koski, G.S. Mills, K.S. Neuhauser, H.D. Radloff, R.F. Weiner, and H.R. Yoshimura. 2000. *Reexamination of Spent Fuel Shipment Risk Estimates*. NUREG/CR–6672, Sandia National Laboratory, Albuquerque, New Mexico. Accession No. ML003698324.

Texas Water Development Board. 2012. *Water for Texas: 2012 State Water Plan*. Austin, Texas. Available at http://www.twdb.state.tx.us/publications/state_water_plan/2012/2012_SWP.pdf.

USACE (U.S. Army Corps of Engineers). 2006. *U.S. Water Demand, Supply, and Allocation: Trends and Outlook*. Report 2007–R–3, Washington, D.C. Available at <http://www.iwr.usace.army.mil/Portals/70/docs/iwrreports/2007-R-03.pdf>.

USCB (U.S. Census Bureau). 2012. *Population Projections*. Washington, D.C. Available at <http://www.census.gov/population/projections/>.

USDA (U.S. Department of Agriculture). 2012. *USDA Agricultural Projections to 2021*. Long-Term Projections Report OCE–2012–1, Washington, D.C. Available at http://www.usda.gov/oce/commodity/archive_projections/USDAAgriculturalProjections2021.pdf.

YAEC (Yankee Atomic Electric Company). 2012. *Decommissioning Study of the Yankee Rowe Independent Spent Fuel Storage Installation*. Rowe, Massachusetts. Accession No. ML12363A107.

7.0 Cost-Benefit Analysis

In this chapter, the U.S. Nuclear Regulatory Commission (NRC) analyzes and compares the benefits and costs associated with the proposed action and the benefits and costs of NRC's potential options in case of no action ("options"). This chapter, along with the rest of this *Generic Environmental Impact Statement for Continued Storage of Spent Nuclear Fuel* (GEIS), informs the NRC's decision regarding whether to implement the proposed action. Only the proposed action—the adoption of a revision to 10 CFR 51.23 to codify the analysis in the GEIS of the environmental impacts of continued storage of spent fuel—satisfies the purpose for the proposed action, which is to preserve the efficiency of the NRC's licensing processes with regard to the environmental impacts of continued storage. Nonetheless, as discussed in Section 1.6.1 of this GEIS, the NRC has multiple options that it could implement if it chose not to adopt a revision to 10 CFR 51.23 to codify the analysis in the GEIS of the environmental impacts of continued storage of spent fuel.

In Chapters 4 and 5 of this GEIS, the NRC discusses the potential impacts of continued at-reactor and away-from-reactor storage, respectively, that may occur under three different continued-storage timeframes. In Chapter 6, the NRC addresses the potential cumulative impacts of continued storage. The proposed action and the NRC's options in case of no action do not alter the NRC's assessment of environmental impacts from continued storage that the NRC addressed in Chapters 4, 5, and 6. The proposed action and the options considered in this chapter instead provide different approaches that the NRC could apply to future licensing activities that can satisfy the need for the proposed action: they provide processes for use in NRC licensing to address the environmental impacts of continued storage. As a result, the costs and benefits shown in this chapter include the specific costs and benefits of the proposed action and NRC's options in case of no action. The costs and benefits do not include the environmental impacts of continued storage, an activity that may occur regardless of the process that the NRC selects to consider the environmental impacts of continued storage. In addition, the costs and benefits addressed in this chapter do not include the potential financial costs of continued storage, which the NRC addresses throughout Chapter 2.

Section 7.1 of this chapter contains the assumptions underlying the NRC's cost-benefit analysis. Section 7.2 contains the costs and benefits of the proposed action (described in Section 1.4), while Section 7.3 contains the costs and benefits of the site-specific review option (described in Section 1.6.1.1). Section 7.4 contains the costs and benefits of the GEIS-only option (described in Section 1.6.1.2), and Section 7.5 contains the costs and benefits of the policy-statement option (described in Section 1.6.1.3). Finally, Section 7.6 contains a summary and comparison of these costs and benefits. Additional details about the NRC's estimated cost calculations are available in Appendix H, Estimated Cost of Alternatives.

7.1 Assumptions

Throughout this chapter, the NRC projects the estimated costs and benefits of various ways the agency can consider the environmental impacts of continued storage. To the extent that the NRC considers cost information, the NRC presents figures in constant 2014 dollars and by applying 3 percent and 7 percent discount rates, as provided in Office of Management and Budget (OMB) Circular A–4 (OMB 2003) and NUREG/BR–0058, Revision 4, *Regulatory Analysis Guidelines for the U.S. Nuclear Regulatory Commission* (NRC 2004).¹

In this analysis, the NRC projects the costs of future environmental reviews conducted from fiscal year 2015 (October 2014 through September 2015) through fiscal year 2044 (October 2043 through September 2044). The NRC adopted this 30-year time period based on the example provided in OMB Circular A–4 and based on the approximate cumulative time period for which previous versions of the Waste Confidence rule (Title 10 of the *Code of Federal Regulations* Section 51.23 [10 CFR 51.23]) have existed. The 30-year time period allows the NRC to make meaningful comparisons between the proposed action and the NRC’s options in case of no action. The 30-year time period begins in the month after the rulemaking is currently scheduled for completion.

In contrast, the NRC estimates the costs of GEIS development and rulemaking activities that occur in fiscal years 2013 and 2014 because that is when the NRC incurred those costs. As a result, these costs are technically past, or “sunk” costs, but the NRC discloses them in its analysis to provide a complete and transparent analysis of the costs of the proposed action and NRC’s potential options in case of no action. In the absence of this cost information, the

¹ The estimated costs provided in this chapter differ from those provided in Chapter 7 of the draft GEIS for several reasons. First, the NRC has updated costs in this chapter to reflect the agency’s latest full-time equivalent (FTE) cost estimate, which is 4 percent lower than the 2012 estimate used to calculate staff costs for the draft GEIS. In addition, where applicable, the NRC has adjusted costs incurred in 2013 to 2014 dollars using the same formula presented in Chapter 2 (this effect tends to be relatively minor and affects only the GEIS and rulemaking costs incurred in 2013). In addition, all future costs are different because the baseline year is now 2014 instead of 2013, which was used in the draft. As a result, there is one less year of discounting. Finally, site-specific review costs for two new reactor applications are higher than they were in the draft GEIS because the NRC now estimates that environmental impact statements (EISs) for these two reviews would require supplementation if the NRC decides to pursue one of the no-action options. The combined effect of these differences is that the costs of the NRC’s options in the case of no action are higher than they were in the draft GEIS because the increased costs of new reactor reviews plus the loss of one year of discounting is larger than the effect of the NRC’s lower FTE rates. At the same time, the cost of the proposed action is lower in the constant-dollars and 3 percent discounting cases than it was for the same cases in the draft GEIS because the effect of the reduced FTE rate is larger than the effects of lost discounting and the Consumer Price Index (CPI) adjustment; however, in the 7 percent discounting case the cost of the proposed action is higher than it was in the draft GEIS because the lost discounting plus the CPI adjustment has a larger effect than the NRC’s reduced FTE rates.

proposed action would appear to have no costs, and the GEIS-only and policy-statement options would entail fewer costs. Because approximately half of the costs of the GEIS development and rulemaking are estimated to have occurred in 2013, the NRC has adjusted 2013 costs in tables throughout this chapter to constant 2014 dollars using the Bureau of Labor Statistics' (BLS') Consumer Price Index (CPI) as described in Section 2.1 of this GEIS (CPI data from BLS 2014). Although the costs of GEIS development and rulemaking activities have been incurred, the NRC does not include these costs for options that do not require their completion (e.g., the estimated cost of the site-specific review option does not include GEIS or rulemaking costs).

The NRC made reasonable assumptions for current and future licensing reviews that inform the NRC's cost estimates. This analysis considers site-specific licensing reviews over 30 years that would rely on 10 CFR 51.23 to address the environmental impacts of continued storage. All assumptions related to NRC costs for continued storage include costs associated with the additional NRC efforts on National Environmental Policy Act of 1969, as amended (NEPA) reviews as well as NRC participation in adjudicatory hearings, as appropriate.

The GEIS assumptions are based in part on NRC projections of current and likely licensing reviews (see, for example, SECY-12-0132 for a list of applications currently under review or projected to begin before the end of fiscal year 2014 [NRC 2012]). The assumptions address three categories of licensing actions: new reactor applications, reactor license renewal applications, and site-specific independent spent fuel storage installations (ISFSI) applications.

The NRC assumes that applicants for new or renewed licenses affected by 10 CFR 51.23 would incur costs in the absence of an updated Rule equal to those the NRC incurs in addressing the impacts of continued storage. As a result, the total costs for site-specific reviews are double the NRC's costs discussed in this chapter. Quantified totals in the tables in this chapter include industry costs. The NRC assumes that applicants will incur additional costs by developing applications that address the environmental impacts of continued storage, responding to the NRC's requests for additional information related to continued storage, and participating in any adjudicatory proceedings related to continued storage.

The NRC may potentially incur some unquantified costs when implementing either the proposed action or any of the NRC's potential options in case of no action because all of these approaches to addressing the environmental impacts of continued storage differ, in some aspects, from the NRC's long-established approach of relying on 10 CFR 51.23 supported by an environmental assessment (EA). These implementation costs are likely to be similar in magnitude for whichever approach the NRC implements.

The NRC calculated its estimated costs based in part on anticipated staff time—measured in full-time equivalents (FTEs)—and anticipated contractor effort, where applicable, measured in contract dollars. The average cost for one NRC staff FTE is \$166,000 per year (based on data

Cost-Benefit Analysis

collected from fiscal year 2013), which is based on the methodology provided in NUREG/CR-4627, *Generic Cost Estimates* (Sciacca 1992). The NRC's estimates of potential licensing actions and associated cost calculations are available in Appendix H, Estimated Costs of Alternatives.

7.1.1 New Reactor Applications

The NRC is currently reviewing nine combined license (COL) applications and one early site permit (ESP) application (see Appendix H, Table H-1, for a list of applications).² In reviewing each COL and ESP application, the NRC develops a site-specific environmental impact statement (EIS) that addresses the potential environmental impacts of the proposed facility. If the NRC takes no action to adopt a revised 10 CFR 51.23, then the NRC would need to separately address the environmental impacts of continued storage in the course of each ongoing and future new-reactor licensing review. The NRC assumes that the first site-specific review of the environmental impacts of continued storage would require more time and effort than subsequent reviews because the first application would be developed with a general approach that could then be used in subsequent application reviews.

In general, COL and ESP application reviews take longer and require more staff effort to complete than other NRC reviews that relied on 10 CFR 51.23. Among other factors, COL and ESP applications frequently include cooperating agencies, while COL proceedings additionally require mandatory hearings prior to a Commission decision on an application. The NRC estimates that the first site-specific review of continued storage in a COL EIS supplement³ would require approximately 3.9 FTEs, or \$647,000, and \$1 million in contractor support (total of \$1.65 million), based on staff experience supplementing COL EISs. The NRC estimates that

² One of the COL applications currently under review, Calvert Cliffs Unit 3, is subject to substantial uncertainty. An NRC Atomic Safety and Licensing Board (ASLB) found that the applicants are ineligible to receive a COL because they are wholly owned by a foreign company, in violation of Commission policy based on Section 103d of the Atomic Energy Act (LBP-12-19). On March 11, 2013, the Commission denied the applicants' appeal of the ASLB's decision (CLI-13-04) (NRC 2013a). The applicants have stated that they intend to find a domestic co-owner for the proposed facility. For the purposes of this analysis, however, the NRC has included the Calvert Cliffs Unit 3 COL application.

³ Under 10 CFR 51.92(a), the NRC prepares a supplement to a final EIS when a proposed action has not yet been taken, but there are either substantial changes in the proposed action that are relevant to environmental concerns or there are new and significant circumstances or information relevant to environmental concerns and bearing on the proposed action or its impacts. For the first three new-reactor reviews, the NRC anticipates that it would supplement final EISs. The supplementation process includes development of a draft supplemental EIS, publication of the draft supplemental EIS, an opportunity for public comments on the draft, NRC efforts to consider and resolve comments, and publication of a final supplemental EIS. This process generally duplicates costs already incurred in a standard EIS process. During the supplementation process, applicants may incur expenses when they develop supplements to existing applications, when they respond to NRC requests for additional information, and when they participate in adjudicatory proceedings related to issues raised during the supplemental EIS process.

the next seven reviews (i.e., six COLs and one ESP) will require supplementation of existing EISs at a cost of approximately 2.9 FTEs, or \$481,000, and \$500,000 in contract support (a total of \$981,000) each. The NRC estimates that two remaining new reactor reviews, which do not require supplementation, will require 0.3 FTE, or \$49,800.⁴ See Appendix H, Table H-1, for new reactor cost calculations.

As noted in Chapter 2 of this GEIS, the NRC is currently engaged in preapplication activities with several applicants for light water small modular reactors. Because the light water reactor fuel that would be used in iPWR (integral pressurized water reactors; a type of small modular reactor) designs is substantially similar to existing light water reactor fuel (i.e., zircaloy clad, low-enriched uranium oxide pellets in square cross-section fuel rod arrays), iPWR fuel is within the scope of the GEIS analysis. The NRC expected to receive applications for NRC review and approval of small modular designs pursuant to 10 CFR Part 52 as early as 2013 (NRC 2013b), but there is no current plan for the NRC to receive or begin review of applications for specific small modular reactor power plants.

Design certification reviews for iPWRs would not require assessments of the impacts of continued storage, but licensing reviews for specific sites would require these assessments. At the time of this GEIS publication, only one licensee, the Tennessee Valley Authority (TVA), has expressed an interest in applying for construction permits pursuant to 10 CFR Part 50 for two to six small modular reactors, with potential subsequent units licensed pursuant to 10 CFR Part 52 (NRC 2013c). In 2011, TVA informed the NRC of its intent to submit a construction permit application (TVA 2011), but TVA has not submitted an application as of the GEIS publication date.

As a result of the substantial uncertainties associated with future small modular reactor licensing reviews, the NRC has not included any small modular reactors in its cost projections. Beyond the uncertainty related to applications, there is some uncertainty about review costs for small modular reactor applications. It is reasonable to assume, however, that the effort necessary to address the environmental impacts of continued storage for small modular reactors will be similar to the effort necessary to address the environmental impacts of continued storage for other new reactor applications. If applicants develop and submit applications for small modular reactors to the NRC, then each additional review activity would require an estimated 0.3 FTE, or \$49,800.

⁴ An additional facility, Watts Bar Nuclear Plant, Unit 2, is a proposed new reactor currently undergoing an operating license review under 10 CFR Part 50. The NRC projects that Watts Bar Nuclear Plant, Unit 2, would require approximately 1.4 FTEs and no contractor support for a review of environmental impacts of continued storage, for a total cost of \$232,000. The approach and format for the Watts Bar Nuclear Plant, Unit 2 EIS (NRC 2011) is substantially similar to EISs developed for reactor license renewal, so the cost projection is the same as the projection applied to plants undergoing license renewal reviews that require EIS supplementation.

7.1.2 Reactor License Renewal

The NRC currently has ten reactor license renewals under review (see Appendix H, Table H-2, for a list of applications). An approved license renewal may add up to 20 years of additional operation to an existing commercial power reactor license (10 CFR 54.31(b)).

In the course of reviewing a license renewal application, the NRC prepares a site-specific supplement to the *GEIS for License Renewal of Nuclear Plants* (License Renewal GEIS, or NUREG-1437). A supplemental EIS for license renewal requires less time and effort than a COL or ESP EIS because the License Renewal GEIS has already addressed many environmental issues, the plant under review has typically been operating at the site for at least 20 years (avoiding the need for a review of alternative sites for the proposed renewal) and its effects on the environment tend to be well understood, and because license renewal typically involves no new construction. In addition, license renewal supplemental EISs typically do not include cooperating agencies and do not require mandatory hearings. If the NRC takes no action to adopt a revised 10 CFR 51.23, then the NRC would need to separately address the environmental impacts of continued storage in the course of each ongoing and future reactor-license-renewal review.

The NRC projects that the first site-specific review of continued storage in a supplemental EIS for license renewal would require more time and effort than subsequent reviews in order to develop a general approach that subsequent reviews would then use. The first review would require an estimated 2.5 FTEs, or \$415,000 based on NRC experience supplementing license renewal EISs. The NRC further projects that some reviews would require supplementation of existing EISs, and these reviews would require approximately 1.4 FTEs, or \$232,000. Reviews that have already begun but that do not require supplementation would require approximately 1.1 FTEs, or \$183,000. Reviews of applications that have not yet been submitted would require approximately 0.3 FTE, or \$49,800, or the same amount of effort as new reactor reviews that do not require supplementation. In addition to reviews already received, the NRC projects that all plants that have yet to apply for license renewal would apply for renewal by 2020 for purposes of this analysis (NRC 2013d).⁵ See Appendix H, Table H-2, for license renewal cost calculations.

Further, the NRC assumes that approximately half of the existing reactor fleet will apply for subsequent license renewal (which could allow plants to operate for a total of up to 80 years) beginning in 2017. The NRC estimates that it will review a total of 28 applications—or one

⁵ Watts Bar Nuclear Plant, Unit 1 is the only unit licensed under 10 CFR Part 50 that is not eligible to request license renewal at the time of GEIS publication. The NRC assumes that this facility will eventually seek a license renewal for purposes of this analysis.

application per year—from 2017 through the end of 2044.⁶ The NRC assumes that the continued storage portion of these NEPA reviews will be substantially similar to the reviews performed during the initial license renewal review. The NRC estimates that subsequent license renewal reviews will require an estimated 0.3 FTE, or \$49,800.

7.1.3 ISFSI Licensing

Currently, 15 sites possess site-specific ISFSI licenses (NRC 2013e), and one potential applicant has expressed an interest in licensing a new away-from-reactor ISFSI (ELEA 2013).⁷ The majority of existing ISFSIs, however, are generally licensed. The NRC does not perform a site-specific review for generally licensed ISFSIs; rather, historically, the NRC has performed an EA (with a finding of no significant impact [FONSI]) for each available cask design, and a facility's ability to possess nuclear materials is subject to its 10 CFR Part 50 or Part 52 license. As a result, the NRC assumes, for purposes of this analysis, that there are no costs associated with general ISFSI licensing related to considering the environmental impacts of continued storage during the 30-year analysis period.

The term for a site-specific ISFSI license must not exceed 40 years (10 CFR 72.42(a)). During site-specific ISFSI licensing (new licenses and license renewals), the NRC typically develops an EA that concludes with a FONSI. To date, every at-reactor site-specific ISFSI EA has reached a FONSI. If the NRC takes no action to adopt a revised 10 CFR 51.23, then the NRC would need to separately address the environmental impacts of continued storage in the course of each ongoing and future site-specific ISFSI review.

The NRC estimates that approximately 0.5 FTE, or \$83,000, is necessary to support site-specific considerations of continued storage matters in the first two ISFSI EAs, both of which

⁶ Commercial nuclear power plant licensees typically apply for license renewal for all reactors at a site at the same time. There are currently 61 sites (Salem and Hope Creek share a site) that host operational commercial power reactors with 10 CFR Part 50 operating licenses or both 10 CFR Part 50 operating licenses and 10 CFR Part 52 combined licenses. Licensees have announced plans to cease nuclear power plant operations at two of these sites, Vermont Yankee and Oyster Creek. Of the remaining 59 sites, licensees at three sites could apply for subsequent license renewal after 2044 (beyond the period of this analysis) and still potentially meet the timely renewal provisions of 10 CFR 2.109 (Comanche Peak Units 1 and 2; Seabrook; and Watts Bar Nuclear Plant, Unit 1). Removing from the analysis the plants whose operators have announced their intent to shut down prior to seeking subsequent renewal leaves a maximum of 56 to 59 currently operating sites whose operators may apply for subsequent license renewal during the analysis period. Because the NRC assumes that operators will apply for subsequent license renewal for approximately half of the operational sites, the NRC includes 28 (half of 56) subsequent-renewal reviews in this analysis. The inclusion of any particular licensing action in this analysis does not prejudice the outcome of any pending or future license renewal review; rather it addresses the potential cost implications of potential subsequent renewals.

⁷ Private Fuel Storage (PFS)—an away-from-reactor ISFSI licensee—applied for and received a site-specific license, but its facility has not been constructed, nor has it taken delivery of spent fuel.

are currently under review. The NRC estimates that later ISFSI EAs will require 0.25 FTE, or \$41,500. See Appendix H, Table H-3, for ISFSI-related cost calculations and a list of affected actions.

7.2 Estimated Costs and Benefits of the Proposed Action

In the proposed action, the NRC adopts an updated Rule, 10 CFR 51.23, which codifies, or adopts into regulation, the analysis in the GEIS of the environmental impacts of continued storage of spent fuel. The update would clarify that, because the impacts of continued storage have been generically assessed in a GEIS and codified in a Rule, the NEPA analyses for future reactor and spent fuel storage facility licensing actions will incorporate or consider, respectively, the impact determinations in the GEIS regarding the environmental impacts of continued storage. The effect of the adoption of the analysis into the Rule means that the NRC will conclusively use the environmental impact determinations from the analysis in individual license proceedings, unless a petitioner satisfies the requirements of 10 CFR 2.335, including a showing of special circumstances, to waive the application of 10 CFR 51.23 in a particular proceeding.

The primary benefit of the proposed action is that it eliminates from site-specific licensing reviews the costs associated with identifying the environmental impacts of continued storage. In addition, this approach is generally consistent with Council on Environmental Quality (CEQ) guidance regarding efficiency and timeliness under NEPA (77 FR 14473), as well as the NRC's longstanding preference for resolving generic issues generically (see, for example, 37 FR 15127).

As shown in Table 7-1, preparation of the GEIS and Rule incurs costs. The NRC estimates that the proposed action requires approximately 23 FTEs (or \$3.82 million) in each of 2013 and 2014, or \$7.64 million total (unadjusted). In addition, the proposed action requires an estimated \$6 million (unadjusted) of contract support spread across the 2 years. Most of the expenditures associated with the proposed action will occur as a result of the GEIS development. The NRC estimates that approximately 6 FTE, or \$1.04 million, of the total expenditure is a result of the rulemaking portion of the proposed action. See Appendix H, Table H-4, for more information regarding GEIS and rulemaking costs.

As noted in Section 7.1, the NRC has adjusted GEIS and rulemaking costs to 2014 dollars using the CPI. In addition, because NRC's costs for the GEIS and rulemaking do not occur in the future, GEIS and rulemaking costs are not affected by discounting. As also noted in Section 7.1, while GEIS and rulemaking costs are technically past, or "sunk" costs, the NRC discloses them in Table 7-1 as costs of the proposed action to provide a complete and transparent analysis of the costs of the proposed action and the NRC's potential options in case of no action.

Table 7-1. Estimated Costs of the Proposed Action

Components	Estimated Costs (millions of 2014 dollars)		
	Constant Dollars	3% Discount Case	7% Discount Case
Site-Specific Review Costs ^(a)	-	-	-
GEIS Costs	\$12.7	\$12.7	\$12.7
Rulemaking Costs	\$1.00	\$1.00	\$1.00
Policy Statement Costs	-	-	-
Estimated Total Cost^(b)	\$13.7	\$13.7	\$13.7

(a) Table 7-1, Table 7-2, Table 7-3, and Table 7-4 contain line items for site-specific review costs, GEIS costs, rulemaking costs, and policy statement costs, respectively. The NRC populates each table according to the components necessary for the action considered in each respective section. Here, the proposed action does not require a policy statement, so the NRC includes no costs for that component in Table 7-1.

(b) Due to rounding, costs may not appear to sum correctly. All costs are rounded to three significant figures.

7.3 Estimated Costs and Benefits of the Site-Specific Review Option

Under the site-specific review option, the NRC would not adopt an updated 10 CFR 51.23, nor would it implement any of the other approaches considered in this GEIS. The NRC would not rely on this GEIS, but it may, however, attempt to make use of some of the work already performed during the development of the GEIS. The NRC would review the generic environmental impacts from continued storage in licensing-specific NEPA reviews that the NRC performs for new reactor licensing, reactor license renewal, ISFSI licensing, and ISFSI license renewal (see Appendix H, Table H-1, Table H-2, and Table H-3 for affected actions and their respective estimated costs). The NRC and license applicants incur the majority of the costs from the site-specific review option. Costs also accrue through NRC adjudicatory activities, which affect the NRC, license applicants, and petitioners or interveners. In general, expenses to petitioners are case-specific and difficult to quantify, so the NRC has not quantified them here. Table 7-2 contains cost estimates for the site-specific review option based on the detailed information presented in Appendix H.

Table 7-2. Constant and Discounted Estimated Costs of the Site-Specific Review Option

Components	Estimated Costs (millions of 2014 dollars)		
	Constant Dollars	3% Discount Case	7% Discount Case
Site-Specific Review Costs	\$27.3	\$24.7	\$22.3
GEIS Costs	-	-	-
Rulemaking Costs	-	-	-
Policy Statement Costs	-	-	-
Estimated Total Cost^(a)	\$27.3	\$24.7	\$22.3

(a) Due to rounding, costs may not appear to sum correctly. All figures are rounded to three significant figures.

Cost-Benefit Analysis

The primary quantifiable benefit of the site-specific review option is that the NRC would not need to prepare a GEIS and Rule or a policy statement (consequently, the past costs of GEIS development and rulemaking, while already incurred, are not included in Table 7-2). Perceptions vary among stakeholders regarding whether reviewing the environmental impacts of continued storage in site-specific licensing actions or being able to challenge the consideration of these impacts in litigation without a waiver is classified as a cost or a benefit. In a site-specific NEPA analysis, the NRC would describe location-specific conditions, address the site-specific impacts of a potential licensing action, and address the impacts of continued storage. The value of reviewing continued storage in site-specific NEPA analyses is difficult to quantify.

Another cost of the site-specific review option relates to increased scheduling uncertainties in licensing due to additional environmental reviews and potential increased litigation associated with continued storage. The effects of schedule uncertainties are likely to be most significant for new reactor or new site-specific ISFSI applicants. Delays can be more costly for new reactor applicants, which could incur billions of dollars of additional expenses if a project is delayed. These costs can include increased financing costs, longer-term accumulation of interest on debt, replacement-power costs, and contractual penalties. Because these costs are highly case-specific, the NRC has not attempted to quantify them.

Applicants for renewed reactor and site-specific ISFSI licenses that submit timely and sufficient renewal applications are protected from schedule uncertainty, at least insofar as continued operations are concerned, by 10 CFR 2.109. Specifically, 10 CFR 2.109 allows for operations of reactors and ISFSIs until the applications have been finally determined, even if final determinations take place after the license expiration dates. Nonetheless, delays may affect applicants' plans to commence activities that may depend upon renewed licenses. Because these types of expenses vary significantly and are case-specific, the NRC has not attempted to quantify them.

7.4 Estimated Costs and Benefits of the GEIS-Only Option

The GEIS-only option is similar to the proposed action insofar as the NRC develops and relies upon this GEIS. It differs because the Commission does not adopt an updated 10 CFR 51.23 that codifies the GEIS findings. Because the Commission does not codify the GEIS findings in this no-action option, the environmental impacts of continued storage remain open to site-specific consideration by the NRC. Petitioners may also challenge an applicant's or the NRC's consideration of the impacts of continued storage without a waiver petition pursuant to 10 CFR 2.335. Reliance on a GEIS to address generic issues, however, is consistent with CEQ guidance regarding efficiency and timeliness under NEPA (77 FR 14473).

The primary benefit of the GEIS-only option relative to the site-specific review option is that it reduces NRC and applicant costs in conducting NEPA reviews. The NRC assumes that

applicants will refer to GEIS findings in environmental reports, and the NRC will incorporate GEIS findings and analyses by reference into NEPA documents for new reactor licensing, reactor license renewals, ISFSI licensing, and ISFSI license renewals. The NRC assumes that reliance on the GEIS in site-specific reviews may resolve concerns for some issues related to continued storage, while other issues may require additional effort to resolve comments, address site-specific litigation, or to establish that the GEIS findings are applicable to a specific licensing proceeding. As a result, the NRC assumes that the GEIS-only option will decrease the cost to the NRC and applicants by 50 percent compared to the site-specific review option at best, and at worst will not reduce the NRC and applicant effort compared to the site-specific review option. Therefore, the NRC presents the costs of the GEIS-only option as a range in Table 7-3.

Table 7-3. Constant and Discounted Estimated Costs of the GEIS-Only Option

Components	Estimated Costs (millions of 2014 dollars)		
	Constant Dollars	3% Discount Case	7% Discount Case
Site-Specific Review Costs	\$13.6 to \$27.3	\$12.4 to \$24.7	\$11.2 to \$22.3
GEIS Costs	\$12.7	\$12.7	\$12.7
Rulemaking Costs	-	-	-
Policy Statement Costs	-	-	-
Estimated Total Cost^(a)	\$26.4 to \$40.0	\$25.1 to \$37.5	\$23.9 to \$35.1

(a) Due to rounding, costs may appear not to sum correctly. All costs are rounded to three significant figures.

As was the case in the site-specific review option, perceptions vary among stakeholders regarding whether reviewing the environmental impacts of continued storage in site-specific licensing actions as part of the GEIS-only option or being able to challenge the consideration of these impacts without a waiver is classified as a cost or a benefit. In a site-specific NEPA analysis, the NRC would describe location-specific conditions, address the site-specific impacts of a potential licensing action, and address the impacts of continued storage.

Preparation of the GEIS, however, requires costs not necessary under the site-specific review alternative, as shown in Table 7-3. GEIS preparation requires an estimated 20 FTEs (or \$3.32 million) in each of 2013 and 2014, or \$6.64 million total (unadjusted). In addition, GEIS preparation requires an estimated \$6 million of contract support spread across the 2 years. See Appendix H, Table H-4, for more information regarding GEIS costs.

As noted in Section 7.1, the NRC has adjusted GEIS costs in Table 7-3 to 2014 dollars using the CPI. In addition, because NRC's costs for the GEIS do not occur in the future, GEIS costs are not affected by discounting. As also noted in Section 7.1, while GEIS costs are technically past, or "sunk" costs, the NRC discloses them in Table 7-3 as costs of the GEIS-only option to provide a complete and transparent analysis of this potential option in the case of no action.

Cost-Benefit Analysis

The NRC does not include the past costs of rulemaking in Table 7-3 because rulemaking is not a necessary component of the GEIS-only option.

Similar to the site-specific review option, another cost of the GEIS-only option relates to increased scheduling uncertainties in licensing due to additional environmental reviews and potential increased litigation associated with continued storage. The effects of schedule uncertainties are likely to be most significant for new reactor or new site-specific ISFSI applicants. Delays can be more costly for new reactor applicants, which could incur billions of dollars of additional expenses if a project is delayed. These costs can include increased financing costs, longer-term accumulation of interest on debt, replacement-power costs, and contractual penalties. Because these costs vary significantly and are case-specific, the NRC has not attempted to quantify them.

Applicants for renewed reactor and site-specific ISFSI licenses that submit timely and sufficient renewal applications are protected from schedule uncertainty, at least insofar as continued operations are concerned, by provisions of 10 CFR 2.109. Specifically, 10 CFR 2.109 allows for operations of reactors and ISFSIs until the applications have been finally determined, even if final determination takes place after the license expiration date. Nonetheless, delays may affect applicants' plans to commence activities that may depend upon renewed licenses. Because these types of expenses are case-specific, the NRC has not attempted to quantify them.

7.5 Estimated Costs and Benefits of the Policy-Statement Option

The policy-statement option in case of no action is similar to the GEIS-only option. As in the GEIS-only option, the policy-statement option would rely on this GEIS to address the environmental impacts of continued storage. In addition, the Commission would develop a policy statement to address specific issues and to bind the NRC in its approach to addressing the environmental impacts of continued storage in site-specific environmental reviews.

As in the GEIS-only option, the Commission does not adopt an updated 10 CFR 51.23 that codifies the GEIS findings. Because the Commission does not codify the GEIS findings in this option, the environmental impacts of continued storage remain open to site-specific consideration by the NRC, within the constraints imposed by the Commission's policy statement. Petitioners may challenge an applicant's or the NRC's consideration of the impacts of continued storage without a waiver petition pursuant to 10 CFR 2.335 and would not be constrained by the Commission's policy statement on continued storage. Reliance on a GEIS, however, to address generic issues is consistent with CEQ guidance regarding efficiency and timeliness under NEPA (77 FR 14473).

In application, the policy-statement option is substantially similar to the GEIS-only option. The primary benefit is that it reduces NRC and applicant effort in conducting reviews, thereby increasing efficiency and thus decreasing cost. The NRC assumes that applicants will refer to GEIS findings in environmental reports, and the NRC will incorporate GEIS findings and analyses by reference into site-specific EISs for new reactors, reactor license renewals, and ISFSI licensing. As in the GEIS-only option, the NRC assumes that reliance on the GEIS in site-specific reviews may resolve concerns for some issues related to continued storage, while other issues may require additional effort to resolve comments, address site-specific litigation, or to establish that the GEIS findings are applicable to a specific licensing proceeding. The NRC assumes that the decreased cost in conducting site-specific reviews under the policy-statement option relative to the site-specific review option is likely to be similar to the decreased effort from the GEIS-only option relative to the site-specific review option. The NRC assumes that the policy-statement option will decrease the cost to the NRC and applicants by an estimated 50 percent relative to the site-specific review option, at best, and at worst will not reduce the NRC and applicant effort compared to the site-specific review option. The NRC therefore presents the cost of the policy-statement option as a range in Table 7-4.

Table 7-4. Constant and Discounted Estimated Costs of the Policy-Statement Option

Components	Estimated Costs (millions of 2014 dollars)		
	Constant Dollars	3% Discount Case	7% Discount Case
Site-Specific Review Costs	\$13.6 to \$27.3	\$12.4 to \$24.7	\$11.2 to \$22.3
GEIS Costs	\$12.7	\$12.7	\$12.7
Rulemaking Costs	-	-	-
Policy Statement Costs	\$0.498	\$0.476	\$0.450
Estimated Total Cost^(a)	\$26.9 to \$40.5	\$25.6 to \$38.0	\$24.3 to \$35.5

(a) Due to rounding, costs may appear not to sum correctly. All costs are rounded to three significant figures.

Preparation of the GEIS and policy statement contribute to the costs of this option. The NRC estimates that a policy statement adds 3 FTEs, or \$498,000 (undiscounted), to the cost estimate for the policy-statement option. GEIS preparation requires an estimated 20 FTEs, or \$3.46 million, in each of 2013 and 2014, or \$6.44 million total (unadjusted). In addition, GEIS preparation requires an estimated \$6 million (unadjusted) of contract support spread across the 2 years. As a result of the effort expended in creating the GEIS and policy statement in addition to the effort expended in performing site-specific reviews, the policy-statement option provides a negative net benefit when compared to the site-specific review option. See Appendix H, Table H-4, for more information regarding GEIS and policy-statement costs.

As noted in Section 7.1, the NRC has adjusted GEIS costs in Table 7-4 to 2014 dollars using the CPI. In addition, because NRC’s costs for the GEIS do not occur in the future, GEIS costs are not affected by discounting. Costs of the policy statement, however, are estimated to occur

Cost-Benefit Analysis

in 2015 and 2016, and so are presented in discounted figures, where appropriate. Also, while GEIS development costs are technically past, or “sunk” costs, the NRC discloses them in Table 7-4 as costs of the policy-statement option to provide a complete and transparent analysis of this potential option in the case of no action. The NRC does not include the past costs of rulemaking in Table 7-4 because rulemaking is not a necessary component of the policy-statement option.

Similar to the site-specific review and GEIS-only options, another cost of the policy-statement option relates to increased scheduling uncertainties in licensing due to additional environmental reviews and potential increased litigation associated with continued storage. The effects of schedule uncertainties are likely to be most significant for new reactor or new site-specific ISFSI applicants. Delays can be more costly for new reactor applicants, which could incur billions of dollars of additional expenses if a project is delayed. These costs can include increased financing costs, longer-term accumulation of interest on debt, replacement-power costs, and contractual penalties. Because these costs vary significantly and are case-specific, the NRC has not attempted to quantify them.

As was the case in the site-specific review option and the GEIS-only option, perceptions vary among stakeholders regarding whether reviewing the environmental impacts of continued storage in site-specific licensing actions as part of the policy-statement option or being able to challenge the consideration of these impacts without a waiver is classified as a cost or a benefit. In a site-specific NEPA analysis, the NRC would describe location-specific conditions, address the site-specific impacts of a potential licensing action, and address the impacts of continued storage.

Applicants for renewed reactor and site-specific ISFSI licenses that submit timely and sufficient renewal applications are protected from schedule uncertainty, where continued operations are concerned, by provisions of 10 CFR 2.109. Specifically, 10 CFR 2.109 allows for operations of reactors and ISFSIs until the applications have been finally determined, even if final determination takes place after the license expiration date. Nonetheless, delays may affect applicants’ plans to commence activities that may depend upon renewed licenses. Because these types of expenses vary significantly and are case-specific, the NRC has not attempted to quantify them.

7.6 Comparison of Alternatives

Table 7-5 summarizes the estimated quantified costs for the proposed action and NRC’s potential options under the no-action alternative. The analysis indicates that the quantified cost for the proposed action is significantly lower than the cost for any of the options under the no-action alternative (see Table 7-5; this disparity would have been even greater if the NRC had not included the past, or “sunk” costs of the GEIS and rulemaking). This occurs primarily

because the NRC does not undertake site-specific reviews of continued storage in the course of individual licensing proceedings as part of the proposed action. For additional detail, see Appendix H, Table H-5.

Table 7-5. Summary of Constant and Discounted Estimated Costs for the Proposed Action and NRC’s Potential Options in the Case of No Action (in millions of 2014 dollars)

Estimated Cost	Proposed Action	GEIS-Only	Policy-Statement	Site-Specific Review
Constant 2014 Dollars	\$13.7	\$26.4 to \$40.0	\$26.9 to \$40.5	\$27.3
3% Discount Case	\$13.7	\$25.1 to \$37.5	\$25.6 to \$38.0	\$24.7
7% Discount Case	\$13.7	\$23.9 to \$35.1	\$24.3 to \$35.5	\$22.3

(a) Due to rounding, some costs may appear not to sum correctly. All costs are rounded to three significant figures.

While the site-specific review option does not require the costs associated with GEIS development and rulemaking, site-specific review costs are significantly higher than the costs of the GEIS development and rulemaking. Also, the GEIS-only and policy-statement options do not require rulemaking, but they result in higher overall costs than the site-specific review option because of their respective up-front costs.

In addition to quantified financial differences between the proposed action and NRC’s options in case of no action, unquantified (qualified) differences also exist. Table 7-6 contains a summary of unquantified costs and benefits of the approaches. First, all of the NRC’s options in case of no action create schedule uncertainties that result from site-specific litigation of generic continued storage issues. While costs that result from these uncertainties may be large, they are difficult to quantify because they vary significantly, and they are case- and fact-dependent.

Perceptions vary among stakeholders regarding whether reviewing the environmental impacts of continued storage in site-specific licensing actions or being able to litigate site-specific issues without a waiver pursuant to 10 CFR 2.335 is classified as a cost or a benefit.

As noted in the introduction to this chapter, the proposed action and each of NRC’s potential options in case of no action provides a means of addressing the environmental impacts of continued storage. The proposed action and NRC’s options in case of no action do not alter the NRC’s assessment of environmental impacts from continued storage presented in Chapters 4, 5, and 6, so the environmental impacts identified in those chapters are applicable regardless of which approach NRC chooses to pursue.

Cost-Benefit Analysis

Table 7-6. Summary of Unquantified Costs and Benefits of the Proposed Action and NRC's Potential Options in Case of No Action

Proposed Action	
<u>Benefits</u>	<u>Costs</u>
<ul style="list-style-type: none"> • Generically resolves a generic issue; avoids unnecessary, repetitive reviews • Removes potential for lengthy, site-specific litigation and resulting delays, except in cases with special circumstances • Consistent with CEQ guidance on efficiency and timeliness, as well as with NRC's long-standing preference for resolving generic issues generically • Avoids potential additional costs from small modular reactor applications 	<ul style="list-style-type: none"> • Public-perception cost from precluding continued storage from site-specific review^(a) • Public-perception cost from being unable to challenge NRC findings without a waiver petition^(a)
Site-Specific Review Option	
<u>Benefits</u>	<u>Costs</u>
<ul style="list-style-type: none"> • Public-perception benefit from site-specific reviews^(a) • Public-perception benefit from the ability to challenge NRC findings without a waiver petition^(a) 	<ul style="list-style-type: none"> • Potential for additional delays due to site-specific litigation, which may incur substantial additional costs • Repetitive consideration of a generic issue • Not consistent with CEQ guidance on efficiency and timeliness or with NRC's long-standing preference for resolving generic issues generically • Potential additional costs from small modular reactor applications
GEIS-Only Option	
<u>Benefits</u>	<u>Costs</u>
<ul style="list-style-type: none"> • Public-perception benefit from site-specific reviews^(a) • Public-perception benefit from the ability to challenge NRC findings without a waiver petition^(a) • Consistent with CEQ guidance on efficiency and timeliness 	<ul style="list-style-type: none"> • Potential for additional delays due to site-specific litigation, which may incur substantial additional costs • Repetitive consideration of a generic issue • Potential additional costs from small modular reactor applications
Policy-Statement Option	
<u>Benefits</u>	<u>Costs</u>
<ul style="list-style-type: none"> • Public-perception benefit from site-specific reviews^(a) • Public-perception benefit from the ability to challenge NRC findings without a waiver petition^(a) • Consistent with CEQ guidance on efficiency and timeliness 	<ul style="list-style-type: none"> • Potential for additional delays due to site-specific litigation, which may incur substantial additional costs • Repetitive consideration of a generic issue • Potential additional costs from small modular reactor applications
<p>(a) The NRC recognizes that perceptions vary among stakeholders regarding whether reviewing environmental impacts of continued storage in site-specific licensing actions or being able to challenge the consideration of these impacts without a waiver is classified as a cost or a benefit. The NRC includes perceptual issues as costs and benefits in this table because there is a record of public interest and concern in scoping and in comments on the draft GEIS regarding how site-specific reviews are (or are not) addressed as part of this rulemaking (see Response D.2.15.4 and responses in Section D.2.15 of Appendix D for additional information).</p>	

7.7 Final Analysis and Final Recommendation

The proposed action (adoption of a revision to 10 CFR 51.23 that codifies the conclusions in this GEIS) has no significant environmental impacts, as addressed in Section 1.6.3. In addition, the proposed action requires only minimal commitments of resources, and only insofar as the NRC consumed materials—like paper—to develop and publish the draft and final GEIS and proposed and final Rule, and to facilitate public involvement and comment at various stages of the project. Finally, the proposed action is an administrative approach to considering the environmental impacts of continued storage in the NRC’s environmental documents, and therefore does not affect the balance between short-term uses of the environment and the maintenance and enhancement of long-term productivity. These findings are consistent with the categorical exclusion contained in 10 CFR 51.22(c)(3)(i).

The NRC recommendation is to select the proposed action—adopting a revision to 10 CFR 51.23 that codifies the impact determinations from the GEIS—as the preferred alternative. In making its recommendation, the NRC has determined that the proposed action is superior to the NRC’s options in the case of no action in terms of both costs and benefits. The NRC recommendation is based on (1) the NRC’s analysis of the cost-benefit balance of the proposed action and its options in the case of no action as presented in this chapter; (2) the NRC’s consideration of public-scoping and draft-stage comments in the development of the GEIS; (3) the lack of environmental impacts associated with either the proposed action or the NRC’s options in the case of no action, as addressed in Section 1.6.3; and (4) the NRC’s determination that the environmental impacts of continued storage analyzed elsewhere in this GEIS are unaffected by the NRC’s choice of a particular administrative approach for considering the environmental impacts of continued storage in NRC licensing processes.

7.8 References

10 CFR Part 2. *Code of Federal Regulations*, Title 10, *Energy*, Part 2, “Agency Rules of Practice and Procedure.” Washington, D.C.

10 CFR Part 50. *Code of Federal Regulations*, Title 10, *Energy*, Part 50, “Domestic Licensing of Production and Utilization Facilities.” Washington, D.C.

10 CFR Part 51. *Code of Federal Regulations*, Title 10, *Energy*, Part 51, “Environmental Protection Regulations for Domestic Licensing and Related Regulatory Functions.” Washington, D.C.

10 CFR Part 52. *Code of Federal Regulations*, Title 10, *Energy*, Part 52, “Licenses, Certifications, and Approvals for Nuclear Power Plants.” Washington, D.C.

Cost-Benefit Analysis

10 CFR Part 54. *Code of Federal Regulations*. Title 10. *Energy*, Part 54. “Requirements For Renewal Of Operating Licenses For Nuclear Power Plants.” Washington, D.C.

10 CFR Part 72. *Code of Federal Regulations*, Title 10, *Energy*, Part 72, “Licensing Requirements for the Independent Storage of Spent Nuclear Fuel, High-Level Radioactive Waste, and Reactor-Related Greater than Class C Waste.” Washington, D.C.

37 FR 15127. July 28, 1972. “Restructuring of Facility License Application Review and Hearing Process.” *Federal Register*, Atomic Energy Commission, Washington, D.C.

77 FR 14473. March 12, 2012. “Final Guidance on Improving the Process for Preparing Efficient and Timely Environmental Reviews Under the National Environmental Policy Act.” *Federal Register*, Council on Environmental Quality, Washington, D.C.

Atomic Energy Act of 1954, as amended. 42 USC 2011 *et seq.*

BLS (U.S. Bureau of Labor Statistics). 2014. “CPI Detailed Report—Data for March 2014.” Washington, D.C. Available at <http://www.bls.gov/cpi/cpid1403.pdf>.

ELEA (Eddy-Lea Energy Alliance). 2013. Letter from J.M. Maddox to C. Haney, dated February 26, 2013, regarding “Notice of Intent to Submit a License Application for Consolidate Used Nuclear Fuel Facility.” Hobbs, New Mexico. Accession No. ML13067A278.

National Environmental Policy Act of 1969 (NEPA), as amended. USC 4321 *et seq.*

NRC (U.S. Nuclear Regulatory Commission). 2004. *Regulatory Analysis Guidelines of the U.S. Nuclear Regulatory Commission*. NUREG/BR-0058, Revision 4, Washington, D.C. Accession No. ML042820192.

NRC (U.S. Nuclear Regulatory Commission). 2011. *Draft Supplemental Environmental Impact Statement Related to the Operation of Watts Bar Nuclear Plant, Unit 2*. NUREG-0498, Supplement 2, Washington, D.C. Accession Nos. ML11298A094, ML11298A095.

NRC (U.S. Nuclear Regulatory Commission). 2012. Memorandum from C. Haney to The Commissioners dated October 3, 2012, regarding “Implementation of Commission Memorandum and Order CLI-12-16 Regarding Waste Confidence Decision and Rule with Enclosure: Licensing Actions Affected by Waste Confidence Remand.” Washington, D.C. Accession No. ML12276A054.

NRC (U.S. Nuclear Regulatory Commission). 2013a. *Memorandum and Order in the Matter of Calvert Cliffs 3 Nuclear Project, LLC and Unistar Nuclear Operating Services, LLC*. CLI-13-04. Rockville, Maryland. Accession No. ML13070A117.

NRC (U.S. Nuclear Regulatory Commission). 2013b. "Advanced Reactors." Washington, D.C. Available at <http://www.nrc.gov/reactors/advanced.html>.

NRC (U.S. Nuclear Regulatory Commission). 2013c. "Tennessee Valley Authority (TVA) Clinch River Site." Washington, D.C. Available at <http://www.nrc.gov/reactors/advanced/clinch-river.html>.

NRC (U.S. Nuclear Regulatory Commission). 2013d. "Status of License Renewal Applications and Industry Activities." Washington, D.C. Available at <http://www.nrc.gov/reactors/operating/licensing/renewal/applications.html>.

NRC (U.S. Nuclear Regulatory Commission). 2013e. *2013–2014 Information Digest*. NUREG–1350, Volume 25, Washington, D.C. Accession No. ML13241A207

OMB (Office of Management and Budget). 2003. *Circular A–4: Regulatory Analysis*. NRC000060, Washington, D.C. Accession No. ML11231A834.

PFS (Private Fuel Storage). 2012. Letter from R.M. Palmberg to NRC, dated December 20, 2012, regarding "Termination of NRC License No. SNM–2513 for Private Fuel Storage LLC." La Crosse, Wisconsin. Accession No. ML12356A063.

Sciacca, F. 1992. *Generic Cost Estimates: Abstracts from Generic Studies for Use in Preparing Regulatory Impact Analyses*. NUREG/CR–4627, Revision 2, Science and Engineering Associates, Inc., Albuquerque, New Mexico. Accession No. ML13137A259.

TVA (Tennessee Valley Authority). 2011. *TVA Voluntary Response to RIS 2011–02*. Chattanooga, Tennessee. Accession No. ML110840713.

8.0 Summary of Environmental Impacts of Continued Storage

The environmental impact determinations in this generic environmental impact statement (GEIS) will be incorporated in the environmental reviews performed by the U.S. Nuclear Regulatory Commission (NRC) for future license applications, as appropriate. Doing so will provide the decisionmaker with a complete picture of the environmental impacts of a proposed licensing action. The analysis in this chapter, therefore, addresses requirements of the National Environmental Policy Act of 1969, as amended (NEPA) for environmental reviews of future licensing actions, with respect to spent nuclear fuel (spent fuel) storage after a reactor's licensed life for operation (continued storage): (1) environmental effects of continued storage, including those that are adverse and unavoidable; (2) irreversible and irretrievable commitments of resources associated with continued storage; and 3) the relationship between local uses of the environment and long-term productivity with respect to continued storage.¹

The NRC's regulations under Title 10 of the *Code of Federal Regulations* (CFR) Part 51 implement NEPA requirements. Section 102(2)(C) of NEPA requires that environmental impact statements (EISs)—including those prepared to support NRC licensing actions—must contain the following information:

- any adverse environmental effects that cannot be avoided, should the licensing action be implemented,
- any irreversible and irretrievable commitments of resources that would be involved in the licensing action should it be implemented, and
- the relationship between local short-term uses of the environment and the maintenance and enhancement of long-term productivity.

As discussed in Chapter 1, and as applied throughout this GEIS, significance categories for potential environmental impacts are characterized as follows:

SMALL—The environmental effects are not detectable or are so minor that they will neither destabilize nor noticeably alter any important attribute of the resource.

MODERATE—The environmental effects are sufficient to alter noticeably, but not to destabilize, important attributes of the resource.

¹ As explained in Chapter 1, the environmental impact determinations summarized in this chapter provide the regulatory basis for the proposed action: adopting a revision to 10 CFR Part 51 to codify the determinations of the GEIS. This rulemaking is not a licensing action and does not authorize continued storage or the creation of spent fuel. The environmental impacts of the rulemaking are addressed in Chapter 1 and Chapter 7.

Summary of Environmental Impacts of Continued Storage

LARGE—The environmental effects are clearly noticeable and are sufficient to destabilize important attributes of the resource.

For some resource areas, the impact determination language is specific to the authorizing regulation, executive order, or guidance.

8.1 Summarized Environmental Impacts of Continued Storage

The tables in this section summarize the environmental impacts from continued storage considered elsewhere in this GEIS. The environmental impacts related to at-reactor continued storage are described in Chapter 4 and are summarized by timeframe in Table 8-1. Impacts associated with away-from-reactor continued storage are described in Chapter 5 and are summarized by timeframe in Table 8-2. Cumulative impacts associated with continued storage when considered along with the impacts of other past, present, and reasonably foreseeable future actions are described in Chapter 6 and summarized with the incremental impacts from Chapters 4 and 5 in Table 8-3.

Table 8-1. Summary of Environmental Impacts of Continued At-Reactoer Storage

Resource Area	Short-Term Storage	Long-Term Storage	Indefinite Storage
Land Use	SMALL	SMALL	SMALL
Socioeconomics	SMALL	SMALL	SMALL
Environmental Justice	Disproportionately high and adverse impacts are not expected.		
Air Quality	SMALL	SMALL	SMALL
Climate Change	SMALL	SMALL	SMALL
Geology and Soils	SMALL	SMALL	SMALL
Surface-Water Quality and Use	SMALL	SMALL	SMALL
Groundwater Quality and Use	SMALL	SMALL	SMALL
Terrestrial Resources	SMALL	SMALL	SMALL
Aquatic Ecology	SMALL	SMALL	SMALL
Special Status Species and Habitat	Impacts for Federally listed threatened and endangered species and Essential Fish Habitat would be determined as part of the consultations for the Endangered Species Act and the Magnuson–Stevens Fishery Conservation and Management Act.		
Historic and Cultural Resources	SMALL	SMALL to LARGE	SMALL to LARGE
Noise	SMALL	SMALL	SMALL
Aesthetics	SMALL	SMALL	SMALL
Waste Management			
LLW	SMALL	SMALL	SMALL
Mixed Waste	SMALL	SMALL	SMALL
Nonradioactive Waste	SMALL	SMALL	SMALL to MODERATE

Summary of Environmental Impacts of Continued Storage

Table 8-1. Summary of Environmental Impacts of Continued At-Reactor Storage (cont'd)

Resource Area	Short-Term Storage	Long-Term Storage	Indefinite Storage
Transportation	SMALL	SMALL	SMALL
Public and Occupational Health	SMALL	SMALL	SMALL
Accidents	SMALL	SMALL	SMALL
Sabotage or Terrorism	SMALL	SMALL	SMALL

Table 8-2. Summary of Environmental Impacts of Continued Storage at an Away-from-Reactor Independent Spent Fuel Storage Installation

Resource Area	Short-Term Storage	Long-Term Storage	Indefinite Storage
Land Use	SMALL	SMALL	SMALL
Socioeconomics	SMALL (adverse) to LARGE (beneficial)	SMALL (adverse) to LARGE (beneficial)	SMALL (adverse) to LARGE (beneficial)
Environmental Justice	Disproportionately high and adverse impacts are not expected.		
Air Quality	SMALL to MODERATE	SMALL	SMALL
Climate Change	SMALL	SMALL	SMALL
Geology and Soils	SMALL	SMALL	SMALL
Surface-Water Quality and Use	SMALL	SMALL	SMALL
Groundwater Quality and Use	SMALL	SMALL	SMALL
Terrestrial Resources	SMALL to MODERATE	SMALL	SMALL
Aquatic Ecology	SMALL	SMALL	SMALL
Special Status Species and Habitat	Impacts for Federally listed threatened and endangered species and Essential Fish Habitat would be determined as part of the consultations for the Endangered Species Act and the Magnuson–Stevens Fishery Conservation and Management Act.		
Historic and Cultural Resources	SMALL to LARGE	SMALL to LARGE	SMALL to LARGE
Noise	SMALL	SMALL	SMALL
Aesthetics	SMALL to MODERATE	SMALL to MODERATE	SMALL to MODERATE
Waste Management			
LLW	SMALL	SMALL	SMALL
Mixed Waste	SMALL	SMALL	SMALL
Nonradioactive Waste	SMALL	SMALL	SMALL to MODERATE
Transportation	SMALL to MODERATE	SMALL to MODERATE	SMALL to MODERATE
Public and Occupational Health	SMALL	SMALL	SMALL
Accidents	SMALL	SMALL	SMALL
Sabotage or Terrorism	SMALL	SMALL	SMALL

Summary of Environmental Impacts of Continued Storage

Table 8-3. Summary of the Cumulative Impacts from Continued Storage When Added to Other Federal and Non-Federal Activities

Resource Area	Incremental Impact from At-Reactor Storage	Incremental Impact from Away-from-Reactor Storage	Cumulative Impact from Continued Storage and other Federal and Non-Federal Activities
Land Use	SMALL	SMALL	SMALL to MODERATE
Socioeconomics	SMALL	SMALL (adverse) to LARGE (beneficial)	SMALL to LARGE
Environmental Justice	Disproportionately high and adverse impacts are not expected.		
Air Quality	SMALL	SMALL to MODERATE	SMALL to MODERATE
Climate Change	SMALL	SMALL	MODERATE
Geology and Soils	SMALL	SMALL	SMALL to MODERATE
Surface-Water Quality and Use	SMALL	SMALL	SMALL to LARGE
Groundwater Quality and Use	SMALL	SMALL	SMALL to LARGE
Terrestrial Resources ^(a)	SMALL	SMALL to MODERATE	SMALL to MODERATE
Aquatic Ecology ^(a)	SMALL	SMALL	SMALL to LARGE
Historic and Cultural Resources	SMALL to LARGE	SMALL to LARGE	SMALL to LARGE
Noise	SMALL	SMALL	SMALL to MODERATE
Aesthetics	SMALL	SMALL to MODERATE	SMALL to MODERATE
Waste Management	SMALL to MODERATE	SMALL to MODERATE	SMALL to LARGE
Transportation	SMALL	SMALL to MODERATE	SMALL to MODERATE
Public and Occupational Health	SMALL	SMALL	SMALL
Accidents	SMALL	SMALL	SMALL

(a) Cumulative impacts on Federally listed threatened and endangered species and Essential Fish Habitat would be determined as part of consultations for the Endangered Species Act and the Magnuson–Stevens Fishery Conservation and Management Act.

8.2 Unavoidable Adverse Environmental Impacts of Continued Storage

Section 102(2)(C)(ii) of NEPA requires that EISs—including those prepared to support NRC licensing actions—must contain information about any adverse environmental effects that cannot be avoided if an action is implemented.

For the purposes of the analysis in this chapter, unavoidable adverse environmental impacts are those potential impacts of continued storage that cannot be avoided due to constraints inherent in using at-reactor and away-from-reactor spent fuel storage facilities for continued storage. The unavoidable adverse environmental impacts associated with continued storage would

Summary of Environmental Impacts of Continued Storage

include impacts of (1) short-term storage in a spent fuel pool, as well as (2) short-term storage, (3) long-term storage, and (4) indefinite dry storage in at-reactor and away-from-reactor independent spent fuel storage installations (ISFSIs). The short-term storage timeframe assumes that a repository becomes available by 60 years after the end of the reactor's licensed life for operation. The long-term storage timeframe assumes that a repository becomes available by 160 years after the end of the reactor's licensed life for operation. The indefinite storage timeframe assumes that a repository does not become available and that the spent fuel is stored in an at-reactor or away-from-reactor ISFSI indefinitely. As discussed in Chapter 1 and Appendix B of this GEIS, the NRC believes that the most likely outcome is that a repository will become available by the end of the short-term timeframe, or within 60 years after the end of the reactor's licensed life for operation.

The short-term storage timeframe involves continued operation of at-reactor spent fuel pool storage and dry storage at an at-reactor or away-from-reactor ISFSI until a repository is available. The long-term storage timeframe involves construction and operation of a dry transfer system (DTS), continued operation of an at-reactor or away-from-reactor ISFSI, and replacement of these facilities within the 100-year period until a repository is available. Indefinite storage continues at an at-reactor or away-from-reactor ISFSI in perpetuity with continued aging management activities and the assumed replacement of the ISFSI and DTS every 100 years.

The potential impacts from the activities occurring within the three continued-storage timeframes on each resource area are described in Chapter 4 for at-reactor storage and in Chapter 5 for away-from-reactor storage. Table 8-1 and Table 8-2 summarize the adverse environmental impacts for each resource area. For at-reactor storage, the unavoidable adverse environmental impacts for each resource area across all timeframes are SMALL with the exception of waste-management impacts in the indefinite storage timeframe, which are SMALL to MODERATE, and historic and cultural resource impacts in the long-term and indefinite storage timeframes, which are SMALL to LARGE. These elevated impact conclusions are influenced, in part, by the uncertainties regarding the specific circumstances of continued storage over lengthy timeframes, including site-specific characteristics that could affect the intensity of potential environmental impacts, and the resulting analysis assumptions that have been made by the NRC as documented in detail in Chapter 4. The potentially MODERATE waste-management impacts are associated with the volume of nonhazardous solid waste generated by assumed facility-replacement activities for only the indefinite timeframe. The NRC considered a range of potential impacts on historic and cultural resources in the GEIS to account for varying scenarios. As discussed in Section 3.11, less-developed or disturbed portions of a power plant site, including areas that were used to support construction of the at-reactor ISFSI, could still contain unknown historic and cultural resources. However, the NRC recognizes that there is uncertainty associated with the degree of prior disturbances and what resources, if any, are present in areas where future ground-disturbing activities (e.g., initial and replacement DTS and

Summary of Environmental Impacts of Continued Storage

replacement ISFSI) could occur. The NRC cannot eliminate the possibility that historic and cultural resources would be affected by construction activities during the long-term and indefinite timeframes because the initial ISFSI could be located within a less-disturbed area with historic and cultural resources in close proximity. Further, resources may be present that would not have been considered significant at the time the initial or replacement facilities were constructed, but could become significant in the future. The analysis concluded with an impact range from SMALL to LARGE. Therefore, generic summarization as a range is appropriate.

For some resource areas the impact determination language is specific to the authorizing regulation, executive order, or guidance. For special status species, impacts would be determined as part of consultations pursuant to Endangered Species Act Section 7 and the Magnuson–Stevens Fishery Conservation and Management Act, as amended. Continued at-reactor storage is not expected to cause disproportionately high and adverse human health and environmental effects on minority and low-income populations. In addition, as indicated in the Commission’s policy statement, environmental justice impacts would be considered during site-specific environmental reviews for specific licensing actions.

For away-from-reactor storage, the unavoidable adverse environmental impacts over all timeframes would be SMALL for most resource areas, and SMALL to MODERATE for air quality, terrestrial ecology, aesthetics, waste management, and transportation. Socioeconomics impacts would range from SMALL (adverse) to LARGE (beneficial), and historic and cultural resource impacts could be SMALL to LARGE. The potential MODERATE impacts on air, terrestrial wildlife, and transportation are based on potential construction-related fugitive-dust emissions, terrestrial wildlife direct and indirect mortalities, terrestrial habitat loss, and temporary construction traffic impacts. The potential MODERATE impacts on aesthetics and waste management are based on noticeable changes to the viewshed from constructing a new ISFSI and the volume of nonhazardous solid waste generated by assumed ISFSI and DTS replacement activities for only the indefinite timeframe. Potential LARGE (beneficial) impacts on socioeconomics would be due to local economic tax revenue increases from an away-from-reactor ISFSI. The MODERATE or LARGE impacts on historic and cultural resources could result if historic and cultural resources are present at a site and, because they cannot be avoided, are impacted by ground-disturbing activities during a particular timeframe. The NRC believes that it is reasonable to assume that the replacement ISFSI and the initial and replacement DTS would be constructed near the existing ISFSI because the licensee would have already characterized and selected the existing ISFSI site to meet NRC siting, safety, and security requirements. Further, the NRC believes that it is reasonable to assume that licensees would generally avoid siting and operating an ISFSI away from the existing licensed area or outside previously characterized areas. The NRC recognizes that there is uncertainty associated with the degree of prior disturbance and what resources, if any, are present in areas where future ground-disturbing activities could occur. The NRC cannot eliminate the possibility that historic and cultural resources would be affected by construction activities because the

initial ISFSI could be located within a less-disturbed area with historic and cultural resources in close proximity. Further, resources may be present after initial construction of the away-from-reactor ISFSI that would not have been considered significant at the time the initial or replacement facilities were constructed, but could become significant in the future. Specifically, these potential historic and cultural resource impacts vary depending on where the facilities are sited, what resources are present, the extent of proposed land disturbance, whether the area has been previously surveyed, and whether the licensee has management plans and procedures that are protective of historic and cultural resources.

Impacts on Federally listed species, designated critical habitat, and essential fish habitat would be based on site-specific conditions and determined as part of consultations pursuant to Endangered Species Act Section 7 and the Magnuson–Stevens Fishery Conservation and Management Act, as amended. Continued storage at an away-from-reactor ISFSI is not expected to cause disproportionately high and adverse human health and environmental effects on minority and low-income populations. In addition, as indicated in the Commission’s policy statement, environmental justice impacts would be considered during site-specific environmental reviews for specific licensing actions.

8.3 Irreversible and Irrecoverable Commitments of Resources Associated with Continued Storage

Section 102(2)(C)(v) of NEPA requires that EISs—including those prepared to support NRC licensing actions—must contain information about irreversible and irretrievable commitments of resources that would occur if an action is implemented. The NRC guidance in NUREG–1748, *Environmental Review Guidance for Licensing Actions Associated with NMSS Programs* (NRC 2003), defines an irreversible commitment as the commitment of environmental resources that cannot be restored. In addition, an irretrievable commitment refers to the commitment of material resources that once used cannot be recycled or restored for other uses by practical means. For purposes of application to environmental reviews associated with future licensing actions, this section addresses the irreversible and irretrievable commitments of resources that would occur as a result of continued storage.

Impacts on land use, terrestrial ecology, aquatic ecology, aesthetics, historic and cultural resources, and waste management would result in irreversible commitments; and replacement of ISFSI components and transportation would result in irretrievable commitments. As finite resources, the loss of historic and cultural resources would constitute irreversible impacts. For the indefinite storage timeframe, land and visual resources allocated for spent fuel storage would be committed in perpetuity because continued operations would preempt other productive land uses, including use as terrestrial ecological habitat, and permanently affect the viewshed. The area of land that would be occupied by at-reactor ISFSI is assumed to be 2.4 ha (6 ac) for both ISFSI and DTS facilities (Section 2.1.2.2) or 330 ha (820 ac) for an away-from-reactor

Summary of Environmental Impacts of Continued Storage

ISFSI (Section 2.1.3). Waste-management activities involving waste treatment, storage, and disposal would result in irreversible commitment of capacity for waste disposal. The largest volume of waste requiring disposal during continued storage would be nonradiological demolition waste (primarily concrete) from replacement of an away-from-reactor ISFSI (308,000 m³ [403,000 yd³]), as described in Section 5.15.2. ISFSI replacement activities would also generate canister waste that would have to be disposed at an approved low-level waste facility (there would be approximately 4,000 canisters at an away-from-reactor ISFSI, as described in Section 5.15.2). Transportation activities would involve irretrievable commitment of resources including vehicle fuel for commuting workers and shipping activities. The commitment of resources for construction of storage facilities and transportation is not expected to have a significant impact relative to the availability of these resources.

8.4 Relationship Between Short-Term Uses of the Environment for Continued Storage and the Maintenance and Enhancement of Long-Term Productivity

Section 102(2)(C)(iv) of NEPA requires that EISs—including EISs prepared to support NRC licensing actions—must contain information about the relationship between local short-term uses of the environment and the maintenance and enhancement of long-term productivity. For the purpose of this section, the NRC considers the relationship between local short-term uses of the environment and the maintenance and enhancement of long-term productivity that occurs from continued storage as may be authorized by future licensing actions.

Consistent with the NRC guidance in NUREG-1748 (NRC 2003), the short-term use period evaluated in this section is the period of time encompassing all continued storage activities defined in Chapter 1 (i.e., the period of analysis of environmental impacts evaluated by the three timeframes in Chapters 4 and 5 of this GEIS). In addition, the long-term productivity period evaluated in this section is the time period beyond continued storage (i.e., based on the NRC guidance in NUREG-1748, the period beyond the future licensing action under review). With respect to the indefinite storage timeframe, however, there is no time period beyond continued storage. As discussed in Chapter 1 and Appendix B of this GEIS, the NRC believes that the most likely outcome is that a repository will become available to accept the spent fuel generated by a reactor by the end of the short-term timeframe, or 60 years after the end of the reactor's licensed life for operation. Because the short-term timeframe is the most likely timeframe, the long-term productivity period considered in this chapter for the indefinite storage timeframe is assumed to begin at the end of the long-term storage timeframe evaluated in Chapters 4 and 5.

The local short-term use of the human environment is summarized in terms of the unavoidable adverse environmental impacts and irreversible and irretrievable commitments of resources summarized in Sections 8.2 and 8.3 and Table 8-1 and Table 8-2. With the exception of the

consumption of depletable resources resulting from the evaluated construction and operations activities, these uses may be classified as short-term.

The maximum long-term impact on productivity would result when an at-reactor or away-from-reactor ISFSI is not immediately dismantled at the end of storage operations, or, as with the indefinite storage timeframe, it remains in operation indefinitely. Consequently, the land occupied by an ISFSI would not be available for any other uses. Most long-term impacts resulting from land-use preemption by ISFSI structures can be eliminated by removing these structures or by converting them to productive uses. Once continued storage ends, the facilities and associated land areas would be decommissioned according to NRC regulations. Once decommissioning is complete, and the NRC license is terminated, the site would be available for other uses. Other potential long-term impacts on productivity include the commitment of land and consumption of disposal capacity necessary to meet waste disposal needs. This commitment of land for disposal would remove land from productive use. In addition, because loss of historic and cultural resources would constitute irreversible impacts, any loss of historic and cultural resources during continued storage would persist as long-term impacts. A small contribution to greenhouse gas emissions would add to the atmospheric burden of emissions that could contribute to potential long-term impacts.

8.5 References

10 CFR Part 51. *Code of Federal Regulations*, Title 10, *Energy*, Part 51, “Environmental Protection Regulations for Domestic Licensing and Related Regulatory Functions.” Washington, D.C.

59 FR 7629. February 16, 1994. “Executive Order 12898: Federal Actions to Address Environmental Justice in Minority Populations and Low-Income Populations.” *Federal Register*, Executive Office of the President, Washington, D.C.

Endangered Species Act of 1973 (ESA). 16 USC 1531 *et seq.*

Magnuson–Stevens Fishery Conservation and Management Act of 1976, as amended. 16 USC 1801 *et seq.*

National Environmental Policy Act of 1969 (NEPA), as amended. USC 4321 *et seq.*

NRC (U.S. Nuclear Regulatory Commission). 2003. *Environmental Review Guidance for Licensing Actions Associated with NMSS Programs*. NUREG–1748, Washington, D.C. Accession No. ML032450279.

9.0 List of Preparers

The overall responsibility for the preparation of this *Generic Environmental Impact Statement* (GEIS) was assigned to the Office of Nuclear Material Safety and Safeguards (NMSS), U.S. Nuclear Regulatory Commission (NRC). NMSS had assistance from other NRC organizations as well as the Pacific Northwest National Laboratory (PNNL) and the Center for Nuclear Waste Regulatory Analyses (CNWRA). Tables 9-1 through 9-3 provide a listing of the NRC, CNWRA, and PNNL staff involved, their experience, and their role in preparing this GEIS.

Table 9-1. List of Preparers—NRC

Name	NRC Office	Experience	Function or Expertise
David Brown	NMSS	B.S., Physics, Muhlenberg College, 1990 M.S., Environmental Health Physics, Clemson University, 1993 Years of Relevant Experience: 21	Air quality, climate change, surface water, groundwater, transportation, public and occupational health, accidents and safeguards
Ralph Cady	RES	B.S., Geology, University of Connecticut, 1974 M.A., Geology, University of Connecticut, 1976 Ph.D., Hydrology, University of Arizona, 1989 Years of Relevant Experience: 25	Spent fuel pool leaks
Keith Compton	RES	B.S., Physics, Rhodes College, 1986 Ph.D., Environmental Engineering and Science, Clemson University, 2001 Years of relevant experience: 23	Spent fuel pool fires
Jennifer Davis	NMSS	B.A., Historic Preservation and Classical Civilization (Archaeology); Mary Washington College, 1996. 2 years of fieldwork; 12 years of experience in NEPA compliance, project management, historic and cultural resource impact analysis and regulatory compliance	Historic and cultural resources, socioeconomic, environmental justice, land use, noise
Kevin Folk	NRR	B.A., Geoenvironmental Studies, Shippensburg University, 1989 MS., Environmental Biology, Hood College, 1997 Years of Relevant Experience: 25	Air quality, geology, hydrology, noise
Michelle Hart	NRO	B.S., Physics, Muskingum College, 1991 M.S., Nuclear Engineering, Ohio State University, 1994 Years of Relevant Experience: 18	Accidents
Donald Helton	RES	B.S., Nuclear Engineering, North Carolina State University, 1999 M.S., Nuclear Engineering, Texas A&M University, 2002 Years of Relevant Experience: 11	Spent fuel pool fires
Merri Horn	NMSS	B.S., Physics, Eastern Illinois University, 1980 M.S., Environmental Systems Engineering, Clemson University, 1987 Years of Relevant Experience: 30	Rule, repository feasibility, and continued safe storage feasibility
Andrew Kugler	NRO	B.S., Mechanical Engineering, Cooper Union, 1978 M.S., Technical Management, Johns Hopkins, 1998 Years of Relevant Experience: 35	Away-from-reactor impacts, GEIS assumptions
Stacey Imboden	NRO	B.S., Pennsylvania State University, 1999 M.S., Clemson University, 2001 Years of Relevant Experience: 13	Climate change

Table 9-1. List of Preparers—NRC (cont'd)

Name	NRC Office	Experience	Function or Expertise
Emily Larson	NRR	B.A., Anthropology (major, emphasis archaeology) and History (minor), University of Minnesota, 2004; M.A., Archaeology, Bangor University, 2006 Years of Relevant Experience: 1 year of fieldwork; 2.5 years of experience in NEPA compliance; historic and cultural resource impact analysis and regulatory compliance	Historic and cultural resources
Sarah Lopas	NMSS	B.A., Molecular Biology, Lehigh University, 2001 MPA, Environmental Science and Policy, Columbia University, 2006 Years of Relevant Experience: 12	Executive summary, outreach
Timothy McCartin	NMSS	B.S., Physics, Xavier University, 1973 M.S., Physics, Wayne State University, 1976 Over 31 years' experience evaluating safety and regulatory compliance of geological disposal facilities	Public and occupational health, accidents and safeguards, repository feasibility and continued safe storage feasibility, Rule
Paul Michalak	NMSS	B.S., Education, Temple University, 1978 M.S., Hydrology, New Mexico Institute of Mining and Technology, 1989 Years of Relevant Experience: 26	Spent fuel pool leaks
Michelle Moser	NRR	B.S., Environmental Sciences, Brown University, 2002 M.S., Biological Sciences, Stanford University, 2005 10 years of experience in ecological research and aquatic ecology, 8 years of experience in cumulative impact assessment and NEPA compliance	Ecology, cumulative impacts
Jessie Muir Quintero	NMSS	B.S., Biosystems Engineering, Clemson University, 2000 M.S., Environmental Engineering and Science, Clemson University, 2002 4 years in environmental compliance and solid waste management, 7 years in NEPA compliance and project management	Project manager, executive summary, Chapter 1
Tom Nicholson	RES	B.S., Geological Sciences, Pennsylvania State University, 1972 M.S., Geology, Stanford University, 1976 Professional Geologist, Indiana Certified Professional Hydrogeologist, AIH Years of Relevant Experience: 39	Senior technical advisor for radionuclide transport in the environment

Table 9-1. List of Preparers—NRC (cont'd)

Name	NRC Office	Experience	Function or Expertise
Jeffrey Rikhoff	NRR	M.R.P., Regional Planning, University of Pennsylvania, 1988 M.S., Economic Development and Appropriate Technology, University of Pennsylvania, 1987 B.A., English (Composition), DePauw University, 1980 Years of Relevant Experience: 26 years of experience in NEPA compliance, socioeconomics and environmental justice impact analysis, cultural resource impacts, and comprehensive land-use and development planning	Socioeconomics, environmental justice
Robert Schaaf	NRO	B., Mechanical Engineering, Georgia Institute of Technology, 1988 Years of Relevant Experience: 24	GEIS Assumptions
Andrew Stuyvenberg	NMSS	B.S., Biochemistry/Molecular Biology and Political Science, Marquette University, 2002 M.E.M., Environmental Economics and Policy, Duke University, 2005 J.D., Georgetown University Law Center Years of Relevant Experience: 9	NEPA alternatives, NEPA process, cost-benefit analysis
Michael Wentzel	NMSS	B.S., Microbiology, University of Texas, 1997 Years of Relevant Experience: 16	Ecological resources, aesthetics, spent fuel pool leaks and fires
NRO = Office of New Reactors. NRR = Office of Nuclear Reactor Regulation. NSIR = Office of Nuclear Security and Incident Response. RES = Office of Nuclear Regulatory Research.			

Table 9-2. List of Preparers—CNWRA

Name	Experience	Function or Expertise
Hakan Basagaoglu	B.S., Geologic Engineering, Middle East Technical University, Turkey, 1991 M.S., Geologic Engineering, Middle East Technical University, Turkey, 1993 Ph.D., Civil and Environmental Engineering, University of California Davis, 2000 Years of Relevant Experience: 3	Groundwater
Amitava Ghosh	B.Tech., Mining Engineering, Indian Institute of Technology, 1978 M.S., Mining Engineering, University of Arizona, 1983 Ph.D., Mining Engineering, University of Arizona, 1990 Years of Relevant Experience: 13	Natural events and accidents
Amy Hester	B.A., Environmental Studies, University of Kansas, 1998 Years of Relevant Experience: 14	Terrestrial resources
Lane Howard	B.S., Civil Engineering, Texas A&M University, 1988 M.S., Nuclear Engineering, Texas A&M University, 1995 Years of Relevant Experience: 23	Public and occupational health
Miriam Juckett	B.A., Chemistry, University of Texas San Antonio, 2003 M.S., Environmental Sciences, University of Texas San Antonio, 2006 Years of Relevant Experience: 11	Communications, scoping, and outreach
Patrick LaPlante	B.S., Environmental Studies, Western Washington University, 1988 M.S., Biostatistics and Epidemiology, Georgetown University, 1994 Years of Relevant Experience: 25	Transportation
Todd Mintz	B.S., Chemical Engineering, Washington University St. Louis, 1998 Ph.D., Materials Science and Engineering, University of California Berkeley, 2003 Years of Relevant Experience: 2	Spent fuel pool fires
Marla Morales	B.A., Geology, Vanderbilt University, 2001 M.S., Geology, University of Texas San Antonio, 2007 Years of Relevant Experience: 13	Socioeconomics, environmental justice, geology, and soils
James Myers	B.S., Geology, Michigan State University, 1985 M.S., Geophysical Sciences, Georgia Institute of Technology, 1990 Ph.D., Environmental Science and Engineering, Clemson University, 2004 Years of Relevant Experience: 21	Solid waste management
Olufemi Osidele	B.S., Civil Engineering, University of Ife, Nigeria, 1987 M.S., Hydrology for Environmental Management, University of London, England, 1992 Ph.D., Environmental Systems Analysis, University of Georgia, 2001 Years of Relevant Experience: 19	Surface water

Table 9-2. List of Preparers—CNWRA (cont'd)

Name	Experience	Function or Expertise
Roberto Pabalan	B.S., Geology, University of the Philippines, 1976 Ph.D., Geochemistry and Mineralogy, Pennsylvania State University, 1986 Years of Relevant Experience: 16	Spent fuel pool leaks
Robert Pauline	B.S., Biology, Bates College, 1989 M.S., Biology, George Mason University, 1999 Years of Relevant Experience: 8	Scoping
English Pearcy	B.S., Geology, Furman University, 1983 M.S., Geology, Harvard University, 1985 Ph.D., Geology, Harvard University, 1989 Years of Relevant Experience: 24	Aesthetics
James Prikrýl	B.S., Geology, University of Texas, 1984 M.S., Geology, University of Texas, 1989 Years of Relevant Experience: 24	Land use
David Turner	B.A. in Music/Geology, College of William and Mary, 1981 M.S. in Geology, University of Utah, 1985 Ph.D. in Geology, University of Utah, 1990 Years of Relevant Experience: 24	Cumulative impacts
Bradley Werling	B.A., Engineering Physics, Westmont College, 1985 B.S., Chemistry, Southwest Texas State University, 1999 M.S., Environmental Science, University of Texas San Antonio, 2000 Years of Relevant Experience: 19	Noise, air quality, climate change

Table 9-3. List of Preparers—PNNL

Name	Experience	Function or Expertise
Eva Hickey	B.S., Biology with Health Physics option, Virginia Polytechnic Institute and State University, 1978 M.S., Health Physics, Georgia Institute of Technology, 1980 Years of Relevant Experience: 35	Accidents
Tara O'Neil	B.A., Anthropology with an emphasis on Archaeology, Oregon State University, 1992 MBA, University of Phoenix, 2009 Years of Relevant Experience: 22	Historic and Cultural Resources
Terri Milley	B.S. Mathematics, University of South Carolina, 1982 M.S. Mathematics, University of South Carolina, 1986 Years of Relevant Experience: 27	Appendix D

10.0 Index

A

- Accident, xxviii, xlvi, xlvii, xlviii, lviii, lix, lxi, lxiv, 2-13, 2-23, 2-39, 3-42, 4-3, 4-18, 4-66, 4-67, 4-71, 4-72, 4-73, 4-74, 4-75, 4-76, 4-79, 4-80, 4-81, 4-82, 4-83, 4-84, 4-85, 4-86, 4-88, 4-89, 4-90, 4-91, 4-92, 4-97, 4-98, 4-104, 4-105, 4-109, 5-19, 5-51, 5-52, 5-54, 5-55, 5-56, 5-57, 5-58, 5-59, 6-51, 6-52, 6-53, 6-55, 6-56, 6-57, 6-59, 6-63, 8-3, 8-4, 9-2, 9-3, 9-5, 9-6, 11-1, 11-5, 11-7, 11-17, 11-18, 11-19, B-4, B-12, B-13, B-14, B-16, B-17, B-20, B-21, B-26, B-30, B-32, B-36, B-37, B-39, B-41, D-5, D-6, D-21, D-22, D-25, D-59, D-68, D-69, D-70, D-71, D-86, D-94, D-95, D-96, D-99, D-104, D-109, D-115, D-124, D-125, D-127, D-129, D-131, D-132, D-133, D-136, D-137, D-144, D-145, D-147, D-148, D-149, D-155, D-160, D-161, D-171, D-175, D-185, D-187, D-190, D-191, D-209, D-212, D-218, D-219, D-220, D-225, D-264, D-265, D-278, D-279, D-280, D-281, D-282, D-283, D-284, D-287, D-289, D-290, D-291, D-293, D-294, D-295, D-296, D-297, D-298, D-299, D-300, D-308, D-310, D-312, D-313, D-314, D-315, D-316, D-317, D-318, D-319, D-320, D-321, D-322, D-323, D-324, D-325, D-326, D-327, D-328, D-329, D-330, D-331, D-332, D-333, D-334, D-335, D-336, D-337, D-338, D-339, D-340, D-341, D-344, D-345, D-346, D-347, D-348, D-349, D-350, D-352, D-355, D-360, D-361, D-366, D-368, D-385, D-386, D-387, D-391, D-393, D-396, D-397, D-398, D-402, D-403, D-404, D-410, D-411, D-417, D-418, D-419, D-420, D-421, D-422, D-423, D-426, D-427, D-429, D-430, D-433, D-434, D-435, D-436, D-438, D-439, D-440, D-442, D-443, D-444, D-445, D-446, D-447, D-449, D-450, D-451, D-452, D-453, D-461, D-467, D-469, D-484, D-485, D-491, D-493, D-495, D-496, D-498, D-499, D-500, D-501, D-507, D-508, D-509, D-514, D-520, D-521, D-527, D-528, D-530, D-533, D-535, D-538, D-539, D-540, D-541, D-542, D-543, D-544, D-545, D-546, D-547, D-606, D-614, D-616, D-617, D-620, D-621, D-626, D-627, D-632, D-633, E-1, E-4, E-9, F-1, F-2, F-3, F-4, F-5, F-6, F-7, F-8, F-9, F-10, F-11, F-12, F-13, F-14, F-15, F-16, F-17, F-18, F-19, F-20, F-21, I-2, I-5, I-7
- Aesthetics, xxxiv, xxxv, xliv, xlviii, xlix, lvi, lix, lxi, lxii, 3-9, 3-30, 3-34, 4-57, 4-58, 4-59, 4-98, 5-13, 5-14, 5-43, 5-44, 5-45, 5-58, 5-59, 6-43, 6-44, 6-45, 6-58, 8-2, 8-3, 8-4, 8-6, 8-7, 9-4, 9-6, 11-1, 11-6, D-5, D-182, D-183, D-185, D-268
- Aging management, xlv, lii, lvi, 1-16, 2-29, 2-31, 4-6, 4-69, 5-7, 5-9, 5-10, 5-14, 5-18, 5-21, 5-23, 5-28, 5-29, 5-30, 5-33, 5-37, 5-42, 5-43, 5-44, 5-52, 5-55, 8-5, 11-1, 11-13, B-17, B-18, B-19, B-20, B-22, B-25, B-28, B-32, B-42, D-31, D-32, D-132, D-159, D-173, D-181, D-286, D-303, D-314, D-390, D-395, D-402, D-413, D-415, D-463, D-464, D-468, D-469, D-473, E-5, I-8
- Air quality, xxxiv, xxxv, xxxvii, xlvii, xlix, I, lix, lx, 3-11, 3-13, 3-43, 3-44, 4-3, 4-14, 4-15, 4-16, 4-17, 4-18, 4-34, 4-98, 5-5, 5-13, 5-15, 5-16, 5-17, 5-18, 5-58, 5-59, 6-18, 6-19, 6-20, 6-58, 8-2, 8-3, 8-4, 8-6, 9-2, 9-6,

Index

- 11-1, 11-4, 11-9, 11-15, D-5, D-207, D-208, D-209, D-210, D-528
- Alternative, xxiii, xxvi, xxviii, xxix, lvii, lxx, 1-6, 1-9, 1-10, 1-11, 1-25, 2-33, 2-34, 4-72, 4-105, 5-28, 5-36, 6-22, 7-1, 7-4, 7-6, 7-11, 7-14, 7-17, 9-4, 11-1, 11-6, 11-9, 11-15, B-24, B-30, D-5, D-13, D-14, D-37, D-38, D-41, D-42, D-46, D-48, D-50, D-60, D-61, D-71, D-72, D-73, D-74, D-77, D-79, D-80, D-81, D-82, D-83, D-85, D-86, D-87, D-88, D-89, D-90, D-91, D-92, D-93, D-94, D-98, D-100, D-104, D-106, D-107, D-109, D-110, D-111, D-112, D-113, D-114, D-115, D-116, D-117, D-118, D-119, D-120, D-121, D-122, D-123, D-124, D-125, D-126, D-128, D-143, D-144, D-152, D-153, D-154, D-176, D-182, D-193, D-316, D-317, D-322, D-323, D-330, D-351, D-357, D-358, D-361, D-368, D-420, D-450, D-462, D-498, D-499, D-500, D-503, D-518, D-524, D-526, D-535, D-536, D-546, D-547, D-551, E-17, F-16, F-19, H-1, H-6
- Aquifer, 3-17, 3-18, 4-25, 4-26, 6-28, 6-30, 11-2, 11-11, D-130, D-225, D-234, D-240, D-273, D-274, D-456, D-457, D-481, D-482, D-485, E-12, E-13, E-14, E-16
- Archaeological resource, 3-30, 11-2
- Attainment, 3-13, 3-14, 4-15, 4-16, 4-17, 5-15, 5-16, 5-17, 5-18, 11-9
- B**
- Bare fuel, 2-13, 2-24, 2-30, 4-16, 4-82, 5-18, 5-21, 6-9, 6-55, 6-57, 11-2, B-18, D-159, D-160, D-286
- Biota, 3-22, 3-23, 4-30, 4-31, 4-39, 4-42, 5-30, 11-1, 11-3, D-222, D-229, D-247, D-249, D-300, D-301, D-307, D-344, D-345, D-456
- Boiling water reactor, 2-3, 2-4, 2-5, 2-6, 2-7, 2-8, 2-18, 3-3, 3-36, 4-2, 4-23, 4-79, 4-88, 4-105, 6-48, 11-3, B-12, B-14, B-19, B-42, D-269, D-271, D-314, D-319, D-322, D-354, D-355, D-358, D-424, D-427, D-438, D-446, D-448, D-450, D-453, D-518, D-541, D-542, D-545, D-546, D-617, D-627, D-629, D-632, E-1, E-2, E-3, E-19, E-20, E-22, E-27, F-3, F-17, F-18, F-21, F-22, G-1, G-3, G-4, G-5, G-6, G-7, G-9, G-11, G-13
- Burnup, xxviii, 2-8, 2-24, 2-28, 2-33, 4-95, 4-96, 11-3, B-9, B-10, B-12, B-15, B-16, B-19, B-22, B-23, B-33, B-37, D-60, D-63, D-137, D-145, D-180, D-269, D-283, D-284, D-285, D-288, D-317, D-322, D-325, D-334, D-395, D-400, D-401, D-403, D-412, D-413, D-414, D-415, D-424, D-433, D-536, D-537, D-617, D-632, F-18, G-10, G-11, G-13, G-14, G-15, I-1, I-2, I-3, I-4, I-5, I-6, I-7, I-8
- C**
- Cladding, 2-2, 2-7, 2-9, 2-11, 2-33, 2-40, 4-3, 4-63, 4-86, 7-5, 11-3, B-10, B-11, B-12, B-14, B-15, B-16, B-31, D-132, D-157, D-177, D-281, D-282, D-284, D-285, D-287, D-288, D-295, D-317, D-318, D-322, D-333, D-334, D-357, D-359, D-360, D-374, D-393, D-395, D-399, D-401, D-402, D-403, D-404, D-413, D-414, D-418, D-428, D-434, D-435, D-436, D-437, D-440, D-445, D-473, D-537, D-614, D-628, F-1, F-9, F-14, I-2, I-3, I-5, I-6
- Clean Air Act, 3-13, 3-14, 3-44, 5-16, 5-61, 6-60, 11-4, 11-9, 11-15, D-607
- Climate change, xxxviii, xlvi, l, lix, lx, 3-45, 3-49, 4-18, 4-79, 4-80, 4-81, 4-83, 4-84, 4-87, 4-89, 4-98, 4-103, 4-109, 5-19, 5-59, 5-65, 6-8, 6-11, 6-21, 6-31, 6-34, 6-

- 58, 6-61, 6-62, 6-66, 8-2, 8-3, 8-4, 9-2, 11-4, B-6, B-35, D-5, D-211, D-212, D-215, D-217, D-495, D-597, D-611, D-615, D-616
- Coastal, 3-6, 3-11, 3-17, 3-20, 3-23, 3-24, 3-25, 3-29, 3-44, 4-46, 4-47, 4-48, 4-79, 4-80, 4-87, 4-101, 4-103, 5-32, 5-33, 5-61, 6-7, 6-11, 6-28, 6-31, 11-2, D-94, D-212, D-213, D-217, D-255, D-256, D-314, D-342, D-611, F-15
- Consolidated storage, 2-20, 11-5, D-303, D-406, D-407, D-408
- Cooling system, xli, 1-17, 2-2, 2-3, 2-4, 2-5, 2-28, 3-1, 3-3, 3-21, 3-22, 3-23, 4-2, 4-22, 4-29, 4-30, 4-31, 4-32, 4-33, 4-36, 4-37, 4-38, 4-39, 4-40, 4-41, 4-42, 4-44, 4-45, 4-46, 4-47, 4-86, 6-9, 6-11, 6-32, 6-35, 11-5, 11-16, D-233, D-241, D-249, D-254, D-256, D-330, D-335, D-396, D-411, D-417, D-468, D-494, D-541
- Core damage frequency, 4-77, 11-5, D-542
- Costs, xxix, lxiv, lxv, 1-25, 2-1, 2-2, 2-12, 2-17, 2-19, 2-21, 2-24, 2-25, 2-26, 2-27, 2-28, 2-29, 2-30, 2-31, 2-32, 2-34, 2-35, 4-12, 4-38, 4-96, 6-16, 7-1, 7-2, 7-3, 7-4, 7-5, 7-7, 7-8, 7-9, 7-10, 7-11, 7-12, 7-13, 7-14, 7-15, 7-16, 7-17, 11-3, B-7, B-27, D-5, D-17, D-25, D-42, D-50, D-60, D-65, D-82, D-88, D-104, D-108, D-120, D-121, D-122, D-123, D-124, D-125, D-126, D-132, D-149, D-157, D-160, D-162, D-164, D-165, D-170, D-173, D-182, D-184, D-185, D-191, D-193, D-197, D-265, D-273, D-274, D-277, D-293, D-316, D-327, D-328, D-336, D-337, D-345, D-346, D-349, D-350, D-367, D-372, D-392, D-408, D-413, D-415, D-421, D-460, D-497, D-498, D-499, D-500, D-501, D-502, D-503, D-504, D-505, D-506, D-519, D-522, D-530, D-531, D-533, D-534, D-540, D-541, D-544, D-548, D-549, D-630, F-4, F-5, F-8, F-9, F-12, F-13, F-14, F-19, H-1, H-2, H-3, H-4, H-5, H-6, H-7, H-8
- Council on Environmental Quality, 1-7, 1-8, 1-23, 3-8, 3-44, 5-20, 6-1, 6-3, 6-4, 6-22, 6-60, 6-61, 7-8, 7-10, 7-12, 7-16, 7-18, 11-5, D-39, D-44, D-45, D-46, D-48, D-76, D-84, D-107, D-108, D-148, D-212, D-215, D-217, D-231, D-234, D-495, D-611
- Critical habitat, xl, xli, liii, 3-28, 4-44, 4-45, 4-47, 4-48, 4-49, 5-31, 5-32, 5-33, 5-34, 6-36, 8-7, 11-5, D-253, D-255
- Criticality, 2-33, 2-34, 4-74, 4-75, 11-6, B-12, B-22, D-163, D-290, D-291, D-295, D-317, D-318, D-320, D-321, D-333, D-334, D-387, D-398, D-399, D-400, D-410, D-468, D-541, D-543, D-546, D-613, D-614, I-2, I-5
- Cultural resource, xxxiv, xxxv, xxxvii, xlii, xliii, xlvi, xlix, liii, liv, lv, lix, lxi, lxii, 3-30, 3-31, 3-32, 4-13, 4-14, 4-49, 4-50, 4-51, 4-52, 4-53, 4-54, 4-97, 4-98, 5-3, 5-12, 5-13, 5-14, 5-35, 5-36, 5-37, 5-38, 5-39, 5-40, 5-58, 5-59, 6-10, 6-37, 6-38, 6-39, 6-58, 8-2, 8-3, 8-4, 8-5, 8-6, 8-7, 8-9, 9-2, 9-3, 9-4, 9-6, 11-6, D-5, D-129, D-202, D-203, D-257, D-258, D-259, D-260, D-261, D-262, D-263, D-264, D-265, D-267

D

- Decommissioning, xxiv, xxxii, xliv, lvi, lx, lxii, lxiv, 1-16, 1-17, 1-18, 1-20, 1-29, 2-3, 2-5, 2-7, 2-10, 2-12, 2-17, 2-19, 2-20, 2-24, 2-25, 2-26, 2-27, 2-28, 2-29, 2-34, 2-35, 2-38, 2-39, 2-40, 3-4, 3-5, 3-7, 3-19, 3-34, 3-41, 3-44, 3-45, 3-46, 3-47, 3-48, 4-2, 4-7, 4-10, 4-11, 4-18, 4-19, 4-25, 4-27, 4-34, 4-52, 4-62, 4-63, 4-64, 4-65, 4-85, 4-102, 4-105, 4-110, 5-3, 5-4, 5-22, 5-32, 5-47, 5-48, 5-63, 5-64, 6-2, 6-3, 6-8, 6-9, 6-11, 6-13, 6-14, 6-15, 6-17, 6-18, 6-19, 6-

Index

- 23, 6-24, 6-26, 6-27, 6-29, 6-32, 6-33, 6-35, 6-36, 6-38, 6-39, 6-41, 6-42, 6-44, 6-47, 6-48, 6-49, 6-51, 6-52, 6-55, 6-56, 6-57, 6-61, 6-62, 6-63, 6-66, 8-9, 11-6, 11-8, 11-19, B-8, B-12, B-14, B-21, B-24, B-34, B-39, B-41, D-6, D-27, D-49, D-60, D-61, D-68, D-69, D-86, D-101, D-103, D-109, D-110, D-111, D-132, D-134, D-135, D-139, D-140, D-141, D-142, D-143, D-149, D-150, D-170, D-182, D-183, D-184, D-185, D-188, D-191, D-194, D-195, D-196, D-197, D-200, D-202, D-205, D-207, D-216, D-233, D-257, D-263, D-273, D-275, D-276, D-328, D-330, D-340, D-361, D-366, D-378, D-382, D-387, D-391, D-396, D-397, D-398, D-423, D-424, D-430, D-431, D-432, D-442, D-444, D-449, D-450, D-451, D-457, D-459, D-461, D-464, D-465, D-466, D-467, D-468, D-469, D-470, D-477, D-484, D-485, D-499, D-500, D-502, D-503, D-504, D-505, D-506, D-507, D-509, D-522, D-545, D-548, D-552, D-562, D-572, D-588, D-597, D-608, D-611, D-621, D-622, D-623, D-630, E-1, E-5, E-6, E-7, E-8, E-19, E-23, E-24, E-25, E-27, E-28, F-1, F-2, F-10, F-11, F-12, F-15, F-16, F-17, F-18, F-21, G-1, G-9, G-18
- Decommissioning GEIS, xxiv, 1-18, 2-5, 6-9, 6-11, 6-13, 6-14, 6-17, 6-19, 6-24, 6-27, 6-29, 6-33, 6-36, 6-38, 6-41, 6-42, 6-44, 6-52, 6-55, 11-6, D-134, D-183
- Department of Energy, 1-1, 1-5, 1-16, 1-20, 1-23, 1-25, 1-26, 1-28, 2-1, 2-10, 2-18, 2-20, 2-21, 2-22, 2-23, 2-30, 2-32, 2-33, 2-37, 2-38, 3-41, 4-3, 4-31, 4-42, 4-63, 4-64, 4-68, 4-72, 4-77, 4-83, 4-89, 4-102, 5-1, 5-20, 5-47, 5-61, 5-62, 5-64, 6-10, 6-14, 6-20, 6-42, 6-46, 6-48, 6-61, 11-6, 11-21, B-3, B-4, B-8, B-16, B-27, B-28, B-29, B-30, B-31, B-34, B-35, B-36, B-38, B-40, B-41, D-12, D-28, D-32, D-48, D-49, D-63, D-68, D-70, D-90, D-94, D-107, D-122, D-125, D-137, D-141, D-156, D-157, D-158, D-164, D-171, D-172, D-173, D-174, D-176, D-177, D-180, D-182, D-183, D-184, D-221, D-222, D-227, D-229, D-248, D-269, D-278, D-290, D-291, D-295, D-296, D-298, D-323, D-324, D-336, D-372, D-375, D-376, D-378, D-379, D-381, D-383, D-384, D-385, D-402, D-403, D-407, D-408, D-412, D-415, D-476, D-497, D-500, D-502, D-503, D-504, D-513, D-518, D-519, D-525, D-526, D-537, D-547, D-548, D-549, D-550, D-551, D-552, D-611, D-612, D-618, D-630, E-4, E-26, G-14, G-15, G-16, I-6, I-7
- Design-basis accidents, xlvi, 4-72, 4-73, 4-74, 4-76, 4-81, 4-82, 4-84, 6-56, 11-1, 11-7, 11-19, D-109, D-127, D-264, D-319, D-346, D-366, D-410, D-509
- Disposal (permanent), xxiii, xxviii, xxxiv, xxxv, xxxvii, xliv, I, Ivi, Ivii, Ixii, 1-1, 1-2, 1-3, 1-4, 1-5, 1-18, 1-20, 1-23, 1-25, 1-26, 1-27, 1-28, 2-4, 2-15, 2-20, 2-21, 2-27, 2-36, 2-37, 3-17, 3-21, 3-34, 3-35, 3-36, 3-37, 3-42, 3-45, 3-49, 4-14, 4-59, 4-60, 4-61, 4-62, 4-63, 4-64, 4-65, 4-67, 4-68, 4-97, 4-102, 5-15, 5-22, 5-45, 5-46, 5-48, 5-52, 5-53, 5-58, 5-61, 5-62, 6-9, 6-10, 6-19, 6-20, 6-42, 6-45, 6-46, 6-47, 6-48, 6-49, 6-50, 6-51, 6-52, 6-61, 8-8, 8-9, 9-3, 11-3, 11-4, 11-5, 11-7, 11-10, 11-11, 11-13, 11-21, B-1, B-2, B-3, B-4, B-5, B-6, B-7, B-8, B-10, B-26, B-27, B-28, B-29, B-30, B-33, B-34, B-35, B-36, B-37, B-40, D-4, D-5, D-7, D-8, D-12, D-13, D-17, D-18, D-19, D-28, D-29, D-32, D-33, D-34, D-37, D-39, D-45, D-49, D-51, D-58, D-59, D-60, D-62, D-66, D-67, D-79, D-83, D-87, D-90, D-93, D-95, D-100, D-104, D-107, D-110, D-115, D-118, D-119, D-122,

- D-134, D-135, D-141, D-143, D-144, D-154, D-163, D-164, D-165, D-166, D-171, D-172, D-173, D-174, D-176, D-178, D-193, D-204, D-237, D-269, D-270, D-271, D-272, D-273, D-274, D-275, D-276, D-277, D-284, D-289, D-294, D-297, D-299, D-327, D-367, D-370, D-371, D-372, D-373, D-374, D-375, D-376, D-377, D-378, D-379, D-380, D-381, D-382, D-383, D-384, D-388, D-393, D-395, D-397, D-407, D-408, D-416, D-499, D-500, D-502, D-503, D-504, D-505, D-506, D-512, D-514, D-516, D-517, D-518, D-523, D-525, D-529, D-548, D-549, D-551, D-552, D-604, D-605, D-609, D-612, D-615, D-616, D-620, D-621, D-630, F-14
- Dose, xxxiv, xxxv, xlv, xlvii, lvii, lviii, lxiv, 2-23, 3-38, 3-39, 3-40, 3-41, 4-10, 4-11, 4-13, 4-26, 4-31, 4-42, 4-60, 4-69, 4-70, 4-71, 4-72, 4-73, 4-75, 4-76, 4-82, 4-83, 4-88, 4-89, 4-94, 4-96, 4-97, 4-101, 4-104, 4-105, 5-3, 5-13, 5-14, 5-52, 5-54, 5-55, 5-56, 5-57, 6-51, 6-53, 6-54, 6-56, 6-57, 11-2, 11-4, 11-6, 11-7, 11-16, 11-17, 11-19, 11-20, B-14, B-17, B-23, B-32, D-127, D-144, D-152, D-161, D-163, D-186, D-229, D-230, D-239, D-244, D-248, D-249, D-264, D-270, D-279, D-283, D-284, D-287, D-290, D-298, D-299, D-300, D-301, D-302, D-303, D-304, D-305, D-306, D-307, D-308, D-309, D-310, D-311, D-312, D-315, D-316, D-318, D-320, D-321, D-324, D-325, D-331, D-345, D-352, D-356, D-390, D-421, D-452, D-460, D-461, D-462, D-465, D-466, D-482, D-487, D-491, D-492, D-493, D-496, D-497, D-540, D-547, D-613, D-619, D-633, E-6, E-16, E-19, E-20, E-24, E-27, E-29, F-2, F-3, F-4, F-6, F-7, F-8, F-12, F-16
- E**
- Earthquake, xxxii, xlvi, lviii, 1-10, 2-12, 3-15, 4-74, 4-76, 4-77, 4-78, 4-81, 4-82, 4-85, 4-86, 4-88, 5-57, 11-15, B-12, B-13, B-19, B-20, B-22, B-42, D-24, D-94, D-147, D-212, D-215, D-218, D-219, D-238, D-283, D-298, D-313, D-314, D-315, D-320, D-322, D-323, D-324, D-334, D-340, D-341, D-342, D-343, D-346, D-348, D-349, D-360, D-366, D-368, D-370, D-389, D-391, D-392, D-394, D-396, D-398, D-406, D-409, D-410, D-440, D-448, D-449, D-450, D-478, D-496, D-508, D-518, D-530, D-532, D-543, D-544, D-545, D-546, D-612, D-629, D-633, E-1, F-3, F-15, F-16, F-17, F-18, F-21, G-2
- Effluent, xxxix, xl, lii, lxiv, 2-4, 2-32, 3-16, 3-39, 3-40, 4-5, 4-23, 4-27, 4-29, 4-31, 4-32, 4-33, 4-34, 4-35, 4-36, 4-39, 4-40, 4-42, 4-43, 4-104, 4-105, 5-13, 5-29, 6-29, 6-57, 11-7, B-23, B-24, D-130, D-131, D-160, D-161, D-190, D-210, D-225, D-226, D-228, D-229, D-236, D-237, D-239, D-242, D-244, D-249, D-255, D-300, D-301, D-305, D-309, D-311, D-390, D-456, D-460, D-461, D-462, D-468, D-474, D-478, D-479, D-480, D-490, D-502, D-521, D-528, D-609, D-619, E-6, E-7, E-13, E-15, E-19, E-20, E-26, E-27, E-28
- Electromagnetic field, 3-22, 4-32, 6-54, 11-8
- Endangered species, xlvii, lix, lxi, 3-28, 4-98, 5-59, 6-59, 8-2, 8-3, 8-4, 11-8, 11-9, D-251, D-253, D-255, D-256
- Entrainment, 3-22, 4-36, 4-37, 4-38, 4-39, 4-46, 6-34, 6-35, 11-8, D-245, D-249, D-250, D-491
- Environmental justice, xxxiv, xxxv, xxxvii, xlvii, xlix, lix, lx, 3-8, 3-10, 3-11, 3-43, 3-44, 4-9, 4-10, 4-11, 4-12, 4-13, 4-14, 4-98, 4-100, 4-105, 4-106, 5-10, 5-11, 5-12,

Index

- 5-13, 5-58, 5-59, 5-61, 6-15, 6-16, 6-18, 6-58, 6-60, 8-2, 8-3, 8-4, 8-6, 8-7, 8-9, 9-2, 9-4, 9-5, 11-9, D-5, D-125, D-198, D-199, D-200, D-201, D-202, D-203, D-204, D-205, D-206, D-207, D-222, D-230, D-259, D-260, D-490, D-491, D-514, D-607
- Environmental Protection Agency, xxvii, xliii, xlv, lv, lxiii, 1-11, 1-12, 1-25, 1-28, 3-8, 3-12, 3-13, 3-14, 3-16, 3-17, 3-19, 3-33, 3-36, 3-39, 3-44, 3-45, 3-46, 4-9, 4-19, 4-26, 4-31, 4-37, 4-55, 4-56, 4-57, 4-61, 4-102, 5-13, 5-17, 5-20, 5-41, 5-42, 5-43, 5-48, 5-62, 6-1, 6-22, 6-40, 6-42, 6-60, 6-62, 11-5, 11-9, 11-14, B-26, C-3, D-7, D-28, D-60, D-130, D-207, D-208, D-216, D-235, D-236, D-246, D-247, D-303, D-328, D-376, D-381, D-383, D-460, D-461, D-462, D-474, D-476, D-479, D-482, D-486, D-495, D-509, D-517, D-561, D-606, D-607, D-613, E-8, E-15, E-16, E-17, E-20, E-26
- Essential Fish Habitat, xlvii, lix, lxi, 3-28, 3-29, 4-44, 4-46, 4-47, 4-48, 4-49, 4-98, 5-32, 5-34, 5-59, 6-59, 8-2, 8-3, 8-4, 8-7, 11-9
- Evacuation, B-14, D-68, D-94, D-185, D-190, D-294, D-315, D-332, D-336, D-337, D-342, D-349, D-441, D-507, D-509, F-4, F-5, F-6, F-8, F-12
- F**
- Findings, 1-2, 1-3, 1-7, 1-8, 1-18, 1-21, 1-29, 2-10, 2-20, 3-44, 3-47, 4-47, 4-53, 4-77, 4-78, 4-86, 4-96, 4-97, 4-107, 5-6, 5-26, 5-34, 5-37, 5-39, 5-58, 6-60, 7-7, 7-10, 7-11, 7-12, 7-13, 7-16, 7-17, 11-8, B-1, B-11, D-7, D-10, D-11, D-22, D-24, D-26, D-28, D-29, D-33, D-40, D-46, D-47, D-52, D-64, D-68, D-73, D-79, D-80, D-85, D-95, D-111, D-113, D-130, D-131, D-155, D-197, D-198, D-202, D-207, D-211, D-213, D-214, D-216, D-229, D-244, D-247, D-249, D-254, D-256, D-259, D-260, D-261, D-285, D-307, D-314, D-316, D-341, D-347, D-348, D-352, D-360, D-367, D-370, D-375, D-376, D-382, D-384, D-411, D-412, D-416, D-417, D-418, D-428, D-438, D-439, D-446, D-449, D-450, D-451, D-463, D-473, D-477, D-479, D-481, D-517, D-607, D-621, H-8
- Fish and Wildlife Service, xli, 3-21, 3-28, 3-29, 3-45, 4-45, 4-46, 4-48, 4-49, 4-103, 5-31, 5-32, 5-33, 5-62, 6-32, 6-35, 6-36, 11-3, 11-8, 11-9, D-253, D-255, D-256, D-615
- Flood, xlvi, 4-74, 4-76, 4-77, 4-78, 4-80, 4-81, 4-82, 4-83, 4-84, 4-88, 4-89, 4-90, 4-104, 4-110, 5-6, 11-15, B-19, D-24, D-215, D-238, D-292, D-313, D-319, D-320, D-321, D-332, D-334, D-340, D-341, D-342, D-343, D-360, D-392, D-394, D-410, D-496, D-508, E-13
- Frequency-weighted consequence, D-422, F-13
- Fuel cycle, 1-18, 1-23, 2-20, 3-39, 3-40, 6-22, 6-46, 6-52, 6-56, 11-10, 11-16, D-12, D-59, D-64, D-65, D-145, D-204, D-216, D-269, D-294, D-304, D-373, D-413, D-491, D-496, D-499, D-517, D-605, D-612
- Fukushima, xxxii, 1-10, 2-12, 2-13, 2-39, 4-78, 4-80, 4-86, 4-109, B-13, B-20, B-22, B-32, B-37, B-41, D-6, D-22, D-68, D-70, D-71, D-94, D-109, D-114, D-132, D-133, D-155, D-212, D-219, D-225, D-238, D-302, D-306, D-313, D-315, D-316, D-320, D-322, D-325, D-326, D-332, D-334, D-335, D-344, D-368, D-386, D-389, D-391, D-392, D-396, D-397, D-398, D-412, D-417, D-418, D-419, D-440, D-442, D-445, D-452, D-453, D-464, D-507, D-508, D-520, D-528, D-530, D-535, D-537, D-538,

D-539, D-541, D-542, D-543, D-544, D-545, D-546, D-547, D-615, D-626, D-627, D-633, F-15, F-16, F-20, F-21

G

Greenhouse gases, xxxiv, xxxv, xxxviii, l, li, lxii, 3-11, 3-12, 3-44, 3-48, 3-49, 4-15, 4-18, 4-19, 4-20, 4-80, 4-102, 4-109, 5-19, 5-20, 5-21, 5-62, 5-65, 6-21, 6-22, 6-60, 6-61, 6-62, 6-66, 8-9, 11-11, D-211, D-212, D-215, D-216, D-217, D-249, D-491, D-495, D-496, D-497, D-607, D-611

Groundwater, xxxiv, xxxv, xxxviii, xxxix, xlvii, li, lii, lix, lxi, lxiii, 2-30, 3-11, 3-15, 3-17, 3-18, 3-19, 3-21, 3-48, 3-49, 4-10, 4-20, 4-22, 4-23, 4-25, 4-26, 4-27, 4-28, 4-30, 4-70, 4-98, 4-108, 5-24, 5-25, 5-26, 5-27, 5-28, 5-59, 6-28, 6-29, 6-30, 6-31, 6-58, 8-2, 8-3, 8-4, 9-2, 9-5, 11-11, 11-12, 11-20, 11-21, B-23, B-40, B-41, D-130, D-131, D-213, D-214, D-220, D-221, D-223, D-224, D-225, D-226, D-227, D-228, D-229, D-230, D-231, D-232, D-233, D-234, D-235, D-237, D-238, D-239, D-240, D-242, D-243, D-244, D-301, D-306, D-334, D-344, D-372, D-454, D-455, D-456, D-457, D-458, D-459, D-460, D-462, D-463, D-464, D-465, D-466, D-467, D-470, D-471, D-472, D-474, D-475, D-476, D-477, D-478, D-479, D-480, D-481, D-482, D-483, D-484, D-485, D-486, D-487, D-490, D-492, D-493, D-505, D-609, D-615, D-618, D-626, D-631, D-633, E-1, E-5, E-6, E-7, E-8, E-9, E-10, E-11, E-12, E-13, E-14, E-15, E-16, E-17, E-18, E-19, E-20, E-21, E-22, E-23, E-24, E-25, E-26, E-27, E-28, E-29

H

Hardened onsite storage, xxvi, xxviii, 1-10, 11-11, D-6, D-59, D-60, D-72, D-113, D-114, D-115, D-116, D-118, D-369, D-405, D-420, D-530, D-531, D-534, D-535, D-536, D-537

Hazardous waste, xxxiv, xxxv, xlv, 3-35, 3-36, 3-37, 3-43, 4-59, 4-61, 4-64, 5-46, 6-47, 11-11, 11-14, D-277, D-505, D-615

High-burnup fuel, xxviii, 1-25, 2-6, 2-8, 2-28, B-9, B-11, B-12, B-16, D-4, D-60, D-72, D-86, D-137, D-138, D-145, D-158, D-162, D-163, D-179, D-283, D-284, D-285, D-287, D-288, D-317, D-318, D-325, D-333, D-334, D-368, D-392, D-395, D-399, D-401, D-402, D-403, D-404, D-411, D-413, D-414, D-415, D-425, D-451, D-536, D-537, F-18, G-1, G-13, G-15, I-1, I-2, I-3, I-4, I-6, I-7

High-level waste, 1-10, 1-24, 1-28, 1-30, 11-12, 11-21, B-40, D-39, D-40, D-48, D-79, D-135, D-172, D-176, D-210, D-290, D-313, D-357, D-364, D-378, D-381, D-384, D-385, D-512, D-519, D-525, D-607, D-630

Human health, xxxiv, xxxv, xxxvii, xlix, l, 3-8, 3-9, 3-10, 3-11, 3-35, 4-9, 4-10, 4-11, 4-12, 4-13, 4-14, 4-71, 4-79, 5-10, 5-11, 5-12, 5-13, 5-14, 5-15, 5-54, 5-55, 5-56, 6-16, 6-17, 6-18, 6-54, 8-6, 8-7, 11-9, 11-11, 11-14, D-58, D-59, D-199, D-200, D-204, D-205, D-206, D-207, D-209, D-259, D-260, D-300, D-301, D-306, D-309, D-344, D-547, F-4

I

Impingement, 3-22, 4-36, 4-37, 4-38, 4-39, 4-46, 6-34, 6-35, 11-12, D-245, D-249, D-250, D-491

Index

Institutional control, xxviii, xxix, xxxi, 1-16, 11-12, B-10, B-26, B-27, B-28, B-29, B-30, B-31, D-5, D-63, D-89, D-107, D-128, D-138, D-139, D-141, D-143, D-153, D-155, D-157, D-170, D-171, D-172, D-173, D-174, D-175, D-176, D-177, D-210, D-247, D-248, D-277, D-464, D-469, D-503, D-550, D-613, D-633

Interim storage, xxxi, 2-4, 2-19, 2-20, 2-38, 2-39, 11-10, 11-12, 11-13, B-5, B-27, D-66, D-89, D-118, D-172, D-179, D-202, D-292, D-347, D-406, D-407, D-409, D-412, D-518, D-623

L

Land use, xxxiv, xxxv, xxxvi, xlvii, xlviii, lii, lix, lx, lxii, 1-16, 2-8, 3-1, 3-3, 3-20, 3-46, 4-3, 4-4, 4-5, 4-6, 4-98, 5-5, 5-6, 5-7, 5-8, 5-29, 5-59, 6-10, 6-11, 6-12, 6-58, 8-2, 8-3, 8-4, 8-7, 9-2, 9-6, D-5, D-23, D-95, D-107, D-168, D-182, D-183, D-184, D-185, D-186, D-187, D-188, D-189, D-191, D-192, D-194, D-195, D-489, F-9

License renewal, xxiii, xxiv, xxxii, xxxiii, xxxix, xl, lvi, lxiv, 1-4, 1-7, 1-13, 1-18, 1-20, 1-22, 1-30, 2-40, 3-1, 3-2, 3-5, 3-11, 3-14, 3-15, 3-19, 3-20, 3-22, 3-25, 3-28, 3-31, 3-32, 3-34, 3-37, 3-47, 3-48, 4-2, 4-3, 4-15, 4-25, 4-29, 4-30, 4-31, 4-32, 4-33, 4-36, 4-37, 4-38, 4-39, 4-40, 4-41, 4-42, 4-43, 4-45, 4-47, 4-50, 4-55, 4-57, 4-59, 4-60, 4-61, 4-63, 4-66, 4-69, 4-70, 4-105, 4-106, 4-107, 4-109, 5-35, 5-38, 5-48, 5-64, 6-4, 6-6, 6-13, 6-17, 6-25, 6-48, 6-49, 6-52, 6-64, 6-65, 7-3, 7-5, 7-6, 7-7, 7-9, 7-11, 7-13, 7-19, 11-13, B-18, B-19, B-25, C-1, C-3, D-20, D-23, D-26, D-28, D-29, D-48, D-51, D-53, D-59, D-65, D-67, D-68, D-70, D-71, D-73, D-74, D-78, D-80, D-88, D-95, D-96, D-101, D-104, D-

105, D-116, D-126, D-133, D-134, D-146, D-150, D-156, D-159, D-183, D-197, D-205, D-206, D-211, D-220, D-234, D-236, D-238, D-240, D-242, D-243, D-244, D-245, D-247, D-248, D-249, D-253, D-254, D-255, D-256, D-260, D-261, D-264, D-266, D-267, D-274, D-275, D-286, D-337, D-344, D-345, D-412, D-457, D-458, D-463, D-469, D-494, D-499, D-503, D-517, D-522, D-526, D-538, D-539, D-541, D-542, D-546, D-620, D-624, D-625, D-630, D-631, E-5, E-24, E-28, F-14, F-16, F-20, F-21, H-1, H-3, H-4, H-5, H-7, H-8

License Renewal GEIS, xxiv, xxxiii, xxxix, xl, lvi, lxiv, 1-13, 1-18, 3-1, 3-2, 3-11, 3-14, 3-15, 3-19, 3-20, 3-22, 3-25, 3-28, 3-31, 3-37, 4-3, 4-15, 4-25, 4-29, 4-30, 4-31, 4-32, 4-33, 4-36, 4-37, 4-38, 4-39, 4-40, 4-41, 4-42, 4-43, 4-50, 4-55, 4-57, 4-59, 4-60, 4-61, 4-66, 4-69, 4-70, 6-4, 6-13, 6-17, 6-48, 6-49, 6-52, 7-6, 11-13, D-59, D-65, D-104, D-105, D-146, D-183, D-234, D-238, D-240, D-242, D-243, D-244, D-245, D-247, D-249, D-253, D-254, D-274, D-275, D-457, D-494, D-538, D-539, F-14, F-16

License termination, 1-23, 1-29, 6-24, D-462, D-485, D-505, D-621, E-9, E-27

Low-level waste, xlv, xlviii, lvi, lvii, lix, 1-18, 1-24, 2-27, 3-34, 3-35, 3-36, 4-59, 4-60, 4-61, 4-62, 4-63, 4-64, 4-65, 4-66, 4-67, 4-68, 4-69, 4-98, 5-45, 5-46, 5-47, 5-48, 5-52, 5-53, 5-59, 6-11, 6-45, 6-46, 6-47, 6-48, 6-49, 6-50, 6-51, 6-52, 8-2, 8-3, 8-8, 11-4, 11-14, 11-21, D-62, D-70, D-178, D-179, D-269, D-270, D-271, D-272, D-273, D-274, D-275, D-276, D-380, D-381, D-387, D-412, D-524, D-630

M

Mitigation, xli, lxiv, 2-36, 3-12, 3-19, 4-37, 4-45, 4-46, 4-47, 4-48, 4-49, 4-53, 5-16, 5-26, 5-30, 5-32, 5-33, 5-35, 5-37, 5-39, 5-44, 6-11, 6-19, 6-24, 6-26, 6-27, 6-29, 6-32, 6-35, 6-36, 6-38, 6-41, 6-46, 6-48, 6-49, 11-1, 11-8, 11-14, D-17, D-38, D-41, D-50, D-61, D-71, D-74, D-83, D-85, D-86, D-87, D-94, D-95, D-98, D-99, D-105, D-106, D-110, D-111, D-113, D-115, D-154, D-187, D-194, D-207, D-255, D-257, D-264, D-316, D-328, D-334, D-343, D-344, D-347, D-350, D-351, D-360, D-361, D-375, D-398, D-399, D-402, D-417, D-426, D-431, D-432, D-470, D-471, D-497, D-518, D-533, E-10, E-26, F-6, F-9, F-15, F-16, F-18, F-21

Mixed oxide fuel, xxxi, xxxii, 2-8, 2-9, 11-14, B-10, B-12, B-16, D-60, D-137, D-179, D-180, D-304, D-398, D-399, D-403, D-411, D-413, D-414, D-415, D-416, D-452, D-453, I-1, I-5

Mixed waste, xxxiv, xxxv, xliv, xlviii, lvi, lvii, lix, 3-35, 3-36, 3-37, 4-59, 4-60, 4-61, 4-63, 4-65, 4-98, 5-45, 5-46, 5-48, 5-59, 6-46, 6-47, 6-48, 6-49, 6-50, 8-2, 8-3, 11-14

Monitoring, xxxii, xxxvi, xxxvii, xxxviii, xxxix, xli, xlii, xliii, I, liv, lv, lxiii, 2-4, 2-15, 2-28, 2-29, 2-30, 2-31, 2-32, 3-11, 3-13, 3-16, 3-17, 3-19, 3-39, 4-3, 4-4, 4-5, 4-7, 4-10, 4-11, 4-12, 4-13, 4-14, 4-15, 4-16, 4-21, 4-23, 4-26, 4-27, 4-31, 4-33, 4-37, 4-43, 4-45, 4-48, 4-51, 4-53, 4-54, 4-55, 4-56, 4-57, 4-62, 4-63, 4-64, 4-70, 4-77, 4-78, 5-3, 5-4, 5-13, 5-14, 5-15, 5-17, 5-29, 5-32, 5-39, 5-40, 5-42, 5-43, 5-46, 5-55, 6-40, 6-54, 11-1, 11-9, 11-13, 11-14, 11-21, B-10, B-22, B-24, B-26, B-28, B-32, B-35, B-40, D-24, D-25, D-46, D-133, D-143, D-157, D-160, D-161, D-165, D-168, D-169,

D-173, D-184, D-188, D-189, D-190, D-194, D-220, D-221, D-224, D-225, D-227, D-230, D-239, D-258, D-261, D-276, D-301, D-307, D-311, D-336, D-364, D-388, D-390, D-395, D-400, D-402, D-411, D-415, D-455, D-456, D-457, D-458, D-463, D-464, D-465, D-466, D-467, D-468, D-470, D-471, D-472, D-474, D-478, D-479, D-480, D-481, D-482, D-483, D-484, D-487, D-491, D-492, D-502, D-526, D-529, D-537, D-609, D-618, D-633, E-4, E-5, E-6, E-7, E-9, E-10, E-16, E-17, E-20, E-23, E-24, E-29

N

National Ambient Air Quality Standards, 3-13, 3-14, 3-46, 5-15, 5-16, 11-15

National Environmental Policy Act, xxiii, xxiv, xxv, xxvi, xxxi, xxxii, xlii, xlvii, xlix, lxi, lxvi, 1-1, 1-3, 1-4, 1-5, 1-6, 1-7, 1-8, 1-9, 1-12, 1-17, 1-18, 1-19, 1-20, 1-21, 1-25, 1-29, 3-8, 3-9, 3-10, 3-32, 3-44, 3-46, 4-2, 4-9, 4-11, 4-12, 4-16, 4-49, 4-51, 4-52, 4-91, 4-104, 5-11, 5-14, 5-33, 5-35, 5-36, 5-37, 5-38, 5-63, 6-1, 6-4, 6-16, 6-39, 6-60, 6-61, 6-62, 7-3, 7-7, 7-8, 7-9, 7-10, 7-11, 7-12, 7-14, 7-18, 8-1, 8-4, 8-7, 8-8, 8-9, 9-2, 9-3, 9-4, 11-5, 11-8, 11-15, B-26, B-28, B-30, B-38, D-5, D-7, D-14, D-16, D-18, D-19, D-20, D-21, D-22, D-23, D-26, D-28, D-29, D-30, D-32, D-34, D-35, D-36, D-37, D-39, D-40, D-43, D-44, D-45, D-46, D-47, D-48, D-49, D-50, D-52, D-53, D-54, D-55, D-57, D-61, D-67, D-68, D-71, D-73, D-75, D-76, D-77, D-78, D-79, D-80, D-81, D-82, D-83, D-84, D-85, D-86, D-87, D-88, D-95, D-99, D-101, D-102, D-105, D-106, D-107, D-108, D-110, D-111, D-112, D-114, D-116, D-121, D-125, D-126, D-127, D-133, D-136, D-139,

Index

- D-140, D-146, D-148, D-151, D-152, D-153, D-154, D-156, D-158, D-160, D-164, D-171, D-173, D-175, D-176, D-198, D-199, D-200, D-201, D-202, D-204, D-206, D-208, D-212, D-214, D-215, D-217, D-218, D-223, D-226, D-231, D-234, D-236, D-239, D-243, D-245, D-252, D-257, D-259, D-260, D-262, D-263, D-267, D-268, D-282, D-285, D-303, D-313, D-318, D-327, D-338, D-339, D-343, D-347, D-349, D-353, D-369, D-382, D-384, D-385, D-407, D-409, D-412, D-417, D-419, D-420, D-424, D-443, D-446, D-447, D-451, D-452, D-458, D-459, D-460, D-461, D-464, D-469, D-470, D-471, D-473, D-487, D-492, D-493, D-495, D-496, D-500, D-513, D-514, D-517, D-518, D-524, D-535, D-550, D-606, D-611, D-618, F-4, G-2, G-17, I-2, I-8
- National Historical Preservation Act, xlii, liv, 3-30, 3-31, 3-32, 3-46, 4-2, 4-13, 4-14, 4-49, 4-50, 4-51, 4-52, 4-53, 4-104, 5-13, 5-35, 5-36, 5-37, 5-38, 5-40, 5-63, 6-38, 6-39, 6-62, 11-15, D-257, D-260, D-262, D-263, D-264, D-265, D-266, D-267, D-618
- National Marine Fisheries Service, xli, 3-28, 3-29, 4-45, 4-46, 4-47, 4-48, 4-49, 4-103, 5-31, 5-32, 5-33, 5-34, 5-62, 6-32, 6-35, 6-36, 11-3, 11-8, 11-15, D-253, D-255, D-256, D-612, D-615, D-619, D-630
- National Pollution Discharge Elimination System, 3-16, 3-17, 3-37, 4-20, 4-22, 4-27, 4-30, 4-31, 4-34, 4-40, 4-42, 4-43, 5-23, 5-30, 6-27, 6-29, 6-32, 6-35, D-235, D-236, D-242, D-245, D-248, D-249, D-250, D-252, D-253, D-254
- Native American, 2-5, 3-3, 3-6, 3-11, 3-31, 4-10, 6-10, 11-2, 11-9, C-2, D-197, D-202
- Natural phenomena, xlvi, lviii, 3-12, 3-15, 4-18, 4-72, 4-74, 4-76, 4-77, 4-79, 4-80, 4-81, 4-82, 4-84, 4-88, 5-19, 5-57, 6-56, 11-7, 11-15, D-109, D-219, D-230, D-232, D-237, D-238, D-264, D-313, D-314, D-315, D-320, D-322, D-324, D-326, D-342, D-343, D-387, D-391, D-394, D-397, D-410, D-478, D-535, D-544
- No-action alternative, 1-6, 1-7, 1-11, 4-72, 7-14, 11-8, 11-15, B-30, B-31, D-42, D-63, D-72, D-74, D-79, D-81, D-82, D-87, D-88, D-89, D-90, D-91, D-92, D-93, D-94, D-100, D-104, D-106, D-107, D-108, D-110, D-111, D-112, D-116, D-117, D-118, D-119, D-120, D-121, D-122, D-123, D-124, D-125, D-176, D-177

O

- Occupational Safety and Health Administration, 3-33, 3-42, 3-43, 4-71, 4-72, 5-55, 6-54, 6-55, 11-16

P

- Population (population density), xxxiv, xxxv, xxxvii, xlix, I, Ix, Ixiv, 2-4, 3-6, 3-7, 3-8, 3-9, 3-10, 3-11, 3-26, 3-31, 3-33, 3-38, 3-40, 3-41, 3-43, 3-46, 3-49, 4-9, 4-10, 4-11, 4-12, 4-13, 4-14, 4-37, 4-38, 4-39, 4-41, 4-47, 4-96, 4-100, 5-2, 5-3, 5-8, 5-9, 5-10, 5-11, 5-12, 5-13, 5-14, 5-15, 5-32, 5-34, 5-43, 5-63, 6-6, 6-7, 6-13, 6-15, 6-16, 6-17, 6-18, 6-35, 6-43, 6-50, 6-54, 6-66, 8-6, 8-7, 8-9, 11-14, 11-16, 11-19, D-94, D-95, D-99, D-144, D-185, D-188, D-190, D-198, D-199, D-200, D-202, D-203, D-204, D-205, D-207, D-240, D-259, D-260, D-264, D-280, D-288, D-293, D-305, D-307, D-310, D-311, D-316, D-318, D-329, D-331, D-340, D-341, D-342, D-348, D-353, D-358, D-406, D-413, D-415, D-421, D-422, D-423, D-424, D-425, D-441, D-442, D-443, D-450, D-451, D-481, D-490, D-494, D-508, D-509, D-532, D-543,

- D-607, D-619, D-625, E-14, F-1, F-3, F-4, F-7, F-8, F-9, F-12, F-13, F-14, F-16
- Postulated accident, xlvi, lviii, 3-15, 4-72, 4-81, 4-88, 4-97, 5-56, 5-58, 6-55, 6-57, 11-7, B-14, D-31, D-98, D-109, D-165, D-218, D-220, D-230, D-232, D-237, D-254, D-256, D-313, D-319, D-321, D-324, D-328, D-331, D-345, D-347, D-393, D-427, D-498, I-2
- Pressurized water reactor, 2-3, 2-5, 2-6, 2-7, 2-8, 2-9, 2-18, 2-34, 3-3, 3-36, 4-2, 4-23, 4-74, 4-79, 4-88, 4-104, 6-48, 7-5, 11-17, B-12, B-14, B-36, B-42, D-67, D-269, D-271, D-304, D-322, D-340, D-357, D-358, D-414, D-424, D-427, D-429, D-439, D-453, D-632, E-1, E-2, E-3, E-19, E-20, E-22, E-27, F-14, F-17, F-22, G-1, G-3, G-4, G-5, G-6, G-7, G-8, G-9, I-3
- Private Fuel Storage Facility, xlvi, 2-1, 2-15, 2-18, 2-19, 2-30, 2-40, 4-9, 5-1, 5-2, 5-5, 5-6, 5-7, 5-8, 5-9, 5-12, 5-14, 5-15, 5-16, 5-17, 5-19, 5-21, 5-23, 5-24, 5-25, 5-26, 5-27, 5-28, 5-30, 5-36, 5-41, 5-42, 5-44, 5-45, 5-46, 5-47, 5-49, 5-50, 5-51, 5-52, 5-54, 5-55, 5-57, 5-62, 5-63, 5-65, 6-9, 6-15, 6-20, 6-27, 6-29, 6-33, 6-36, 6-42, 6-44, 6-53, 6-55, 7-7, 7-19, 11-17, B-18, B-19, B-39, D-52, D-66, D-102, D-128, D-155, D-181, D-197, D-198, D-206, D-208, D-251, D-252, D-268, D-285, D-407, D-525, D-526, G-1, G-15, G-17
- R**
- Radionuclide, xxxix, lxiii, 2-26, 3-19, 3-20, 3-37, 4-20, 4-22, 4-26, 4-31, 4-36, 4-41, 4-42, 4-70, 4-83, 6-30, 9-3, 11-11, 11-17, B-3, B-20, B-24, B-31, D-101, D-137, D-147, D-177, D-179, D-181, D-214, D-220, D-222, D-229, D-232, D-247, D-248, D-270, D-273, D-284, D-300, D-302, D-304, D-305, D-308, D-325, D-329, D-354, D-371, D-372, D-404, D-414, D-434, D-457, D-460, D-461, D-465, D-472, D-480, D-482, D-485, D-487, D-490, D-492, D-505, D-519, E-6, E-7, E-8, E-9, E-11, E-12, E-13, E-15, E-16, E-17, E-18, E-19, E-20, E-21, E-23, E-25, F-4, F-11, F-13, I-2
- Remediation, 11-18, B-29, B-38, D-157, D-171, D-175, D-246, D-328, D-456, D-460, D-462, D-471, D-486, D-504, D-618, D-631, E-6, E-7, E-8, E-15, E-17, E-24, E-27, E-29
- Repackaging, xxxi, xl, xliv, xlvi, xlix, 2-20, 2-21, 2-23, 2-30, 2-31, 2-32, 2-33, 4-5, 4-6, 4-16, 4-34, 4-35, 4-62, 4-63, 4-64, 4-67, 4-68, 4-69, 4-72, 4-82, 4-83, 4-89, 5-7, 5-18, 5-21, 5-26, 5-28, 5-46, 5-47, 5-53, 5-56, 11-7, 11-18, B-17, B-18, B-20, B-32, D-132, D-143, D-144, D-152, D-157, D-159, D-180, D-181, D-224, D-270, D-272, D-286, D-324, D-402, D-405, D-532
- Repository (geologic), xxiii, xxiv, xxvi, xxx, xxxii, xlix, liii, lxv, lxvi, 1-1, 1-2, 1-3, 1-4, 1-10, 1-12, 1-15, 1-20, 1-23, 1-25, 1-26, 1-28, 2-15, 2-20, 2-29, 2-30, 2-35, 2-40, 4-1, 4-2, 4-5, 4-6, 4-9, 4-14, 4-17, 4-20, 4-21, 4-24, 4-28, 4-54, 4-57, 4-59, 4-66, 4-69, 4-71, 4-72, 4-102, 5-3, 5-4, 5-5, 5-8, 5-10, 5-18, 5-20, 5-21, 5-23, 5-25, 5-26, 5-29, 5-31, 5-34, 5-45, 5-48, 5-49, 5-54, 5-56, 5-61, 5-64, 6-9, 6-10, 6-14, 6-19, 6-20, 6-26, 6-29, 6-32, 6-35, 6-41, 6-42, 6-47, 6-48, 6-51, 6-52, 6-53, 6-55, 6-61, 8-5, 8-8, 9-2, 9-3, 11-3, 11-5, 11-11, 11-13, 11-18, 11-21, B-1, B-2, B-3, B-4, B-5, B-6, B-7, B-8, B-9, B-10, B-26, B-27, B-28, B-29, B-30, B-33, B-34, B-35, B-38, B-40, B-41, D-6, D-7, D-8, D-11, D-12, D-13, D-17, D-22, D-23, D-28, D-30, D-31, D-33, D-34, D-37, D-38, D-45, D-48, D-49, D-52, D-53, D-59, D-60, D-61, D-62, D-64,

Index

- D-65, D-66, D-67, D-72, D-78, D-79, D-86, D-87, D-90, D-93, D-95, D-105, D-114, D-116, D-117, D-118, D-119, D-120, D-122, D-123, D-129, D-134, D-135, D-136, D-137, D-138, D-139, D-140, D-141, D-143, D-144, D-154, D-155, D-157, D-160, D-162, D-163, D-164, D-166, D-171, D-172, D-173, D-174, D-176, D-180, D-188, D-192, D-194, D-195, D-197, D-200, D-202, D-205, D-260, D-290, D-294, D-305, D-344, D-367, D-368, D-370, D-371, D-372, D-373, D-374, D-375, D-376, D-377, D-378, D-379, D-380, D-381, D-382, D-383, D-384, D-385, D-386, D-388, D-397, D-406, D-407, D-408, D-416, D-455, D-491, D-499, D-500, D-501, D-502, D-503, D-504, D-505, D-506, D-512, D-516, D-517, D-518, D-519, D-525, D-532, D-547, D-548, D-549, D-551, D-604, D-612, D-621, D-630, E-1
- Reprocessing, xxvi, xxvii, 1-24, 2-1, 2-11, 2-12, 4-2, 5-49, 11-10, 11-12, 11-18, D-7, D-62, D-67, D-93, D-376, D-389, D-413, D-415, D-520, D-524, E-4
- Risk, xxxiii, xlv, xlvii, lix, lxiv, 1-1, 1-3, 1-9, 1-24, 2-12, 2-21, 2-32, 3-8, 3-9, 3-10, 3-12, 3-39, 3-42, 4-10, 4-27, 4-66, 4-71, 4-72, 4-73, 4-75, 4-76, 4-77, 4-78, 4-79, 4-80, 4-81, 4-84, 4-85, 4-86, 4-87, 4-88, 4-89, 4-90, 4-91, 4-94, 4-97, 4-103, 4-104, 4-105, 4-107, 4-108, 5-13, 5-51, 5-52, 5-55, 5-58, 5-65, 6-16, 6-17, 6-22, 6-51, 6-52, 6-53, 6-55, 6-56, 6-57, 6-63, 6-66, 11-18, B-7, B-12, B-13, B-14, B-19, B-28, B-29, B-30, B-39, B-40, D-29, D-47, D-50, D-52, D-68, D-70, D-86, D-87, D-96, D-98, D-105, D-107, D-108, D-113, D-114, D-115, D-127, D-130, D-131, D-141, D-144, D-145, D-147, D-148, D-153, D-154, D-161, D-162, D-173, D-175, D-176, D-178, D-185, D-188, D-189, D-190, D-193, D-203, D-207, D-217, D-219, D-222, D-229, D-231, D-232, D-234, D-235, D-247, D-264, D-265, D-270, D-277, D-278, D-279, D-280, D-281, D-282, D-283, D-285, D-287, D-289, D-290, D-292, D-293, D-294, D-295, D-296, D-297, D-298, D-299, D-303, D-304, D-305, D-306, D-308, D-309, D-311, D-312, D-313, D-315, D-316, D-317, D-318, D-319, D-320, D-321, D-322, D-323, D-324, D-325, D-326, D-327, D-328, D-329, D-330, D-331, D-332, D-338, D-339, D-340, D-341, D-342, D-343, D-344, D-345, D-347, D-348, D-349, D-350, D-351, D-352, D-353, D-354, D-355, D-356, D-357, D-358, D-359, D-360, D-361, D-364, D-366, D-368, D-369, D-370, D-374, D-386, D-391, D-394, D-396, D-397, D-398, D-403, D-406, D-407, D-408, D-412, D-417, D-418, D-419, D-420, D-421, D-422, D-423, D-424, D-428, D-439, D-440, D-442, D-443, D-447, D-448, D-449, D-451, D-452, D-457, D-458, D-459, D-460, D-475, D-487, D-494, D-495, D-496, D-498, D-504, D-509, D-523, D-525, D-528, D-530, D-532, D-533, D-535, D-536, D-538, D-542, D-543, D-545, D-547, D-551, D-609, D-610, D-613, D-614, D-616, D-618, D-620, D-621, D-624, D-625, D-631, D-632, D-633, F-1, F-2, F-3, F-5, F-7, F-8, F-10, F-12, F-13, F-14, F-15, F-16, F-17, F-18, F-20, F-21
- Rulemaking, xxiii, xxiv, xxv, xxvi, xxvii, xxviii, xxix, 1-1, 1-2, 1-3, 1-6, 1-9, 1-10, 1-23, 1-26, 1-27, 1-28, 1-29, 1-30, 2-12, 2-13, 3-10, 3-32, 4-49, 4-93, 4-100, 5-35, 7-2, 7-8, 7-9, 7-10, 7-11, 7-12, 7-13, 7-14, 7-15, 7-16, 8-1, 11-15, 11-18, 11-21, B-20, C-2, C-3, C-4, C-5, C-6, C-7, C-8, C-9, C-12, C-13, C-15, C-17, D-1, D-3, D-4, D-5, D-7, D-9, D-11, D-12, D-13, D-14, D-15, D-16, D-17, D-18, D-19, D-20, D-21, D-25,

D-26, D-33, D-35, D-36, D-39, D-40, D-41, D-42, D-44, D-45, D-48, D-51, D-54, D-55, D-56, D-57, D-58, D-59, D-61, D-62, D-64, D-65, D-66, D-68, D-72, D-73, D-74, D-77, D-80, D-81, D-82, D-83, D-84, D-85, D-88, D-89, D-108, D-110, D-111, D-112, D-113, D-116, D-117, D-118, D-119, D-120, D-121, D-123, D-145, D-151, D-201, D-205, D-206, D-208, D-218, D-219, D-238, D-240, D-260, D-263, D-266, D-295, D-299, D-306, D-307, D-316, D-334, D-336, D-355, D-360, D-368, D-378, D-394, D-404, D-405, D-410, D-431, D-432, D-448, D-462, D-485, D-503, D-507, D-512, D-514, D-516, D-517, D-519, D-520, D-522, D-523, D-524, D-525, D-533, D-534, D-537, D-545, D-547, D-550, D-552, D-555, D-607, D-608, D-621, D-628, E-9, E-27, F-15, F-16, F-19, H-1, H-6, H-7

S

Safety, xxxii, xlv, xlvi, lvii, lviii, lxiii, 1-1, 1-9, 1-16, 1-25, 2-2, 2-5, 2-6, 2-12, 2-13, 2-15, 2-21, 2-23, 2-27, 2-29, 2-32, 2-33, 2-34, 2-37, 2-38, 2-39, 2-40, 3-6, 3-7, 3-13, 3-15, 3-39, 3-42, 3-45, 3-48, 3-49, 4-2, 4-4, 4-52, 4-64, 4-66, 4-67, 4-69, 4-71, 4-72, 4-73, 4-74, 4-75, 4-76, 4-77, 4-78, 4-79, 4-80, 4-81, 4-82, 4-83, 4-84, 4-85, 4-87, 4-89, 4-90, 4-93, 4-94, 4-95, 4-102, 4-104, 4-107, 4-108, 4-110, 5-1, 5-35, 5-39, 5-52, 5-53, 5-55, 5-57, 5-60, 5-61, 5-62, 6-14, 6-56, 6-57, 6-59, 6-60, 6-61, 7-4, 8-6, 9-1, 9-3, 11-2, 11-5, 11-6, 11-7, 11-11, 11-14, 11-15, 11-16, 11-18, 11-19, 11-20, 11-21, B-2, B-3, B-4, B-5, B-6, B-7, B-8, B-12, B-13, B-14, B-16, B-17, B-18, B-19, B-20, B-21, B-22, B-23, B-25, B-26, B-28, B-29, B-30, B-32, B-33, B-36, B-37, B-38,

B-40, B-41, B-42, D-7, D-8, D-9, D-15, D-16, D-17, D-18, D-19, D-21, D-25, D-26, D-28, D-29, D-30, D-31, D-36, D-37, D-38, D-52, D-58, D-59, D-62, D-64, D-68, D-69, D-70, D-75, D-85, D-86, D-87, D-89, D-92, D-96, D-100, D-101, D-109, D-114, D-115, D-116, D-117, D-118, D-127, D-131, D-132, D-133, D-135, D-139, D-140, D-141, D-142, D-145, D-146, D-147, D-149, D-155, D-156, D-159, D-160, D-161, D-163, D-169, D-173, D-174, D-175, D-181, D-182, D-188, D-192, D-193, D-196, D-197, D-198, D-207, D-210, D-211, D-212, D-213, D-214, D-218, D-219, D-230, D-235, D-236, D-238, D-242, D-244, D-253, D-264, D-265, D-269, D-278, D-279, D-282, D-283, D-285, D-286, D-287, D-288, D-289, D-290, D-291, D-292, D-294, D-295, D-296, D-297, D-298, D-299, D-300, D-301, D-306, D-307, D-311, D-313, D-314, D-316, D-317, D-318, D-319, D-320, D-321, D-323, D-324, D-325, D-327, D-330, D-332, D-333, D-335, D-336, D-337, D-341, D-343, D-348, D-349, D-356, D-357, D-362, D-364, D-366, D-368, D-371, D-372, D-374, D-376, D-378, D-379, D-383, D-384, D-385, D-386, D-387, D-388, D-390, D-391, D-392, D-393, D-394, D-395, D-397, D-398, D-399, D-400, D-401, D-402, D-403, D-404, D-405, D-407, D-409, D-410, D-411, D-412, D-414, D-417, D-422, D-440, D-449, D-455, D-457, D-459, D-461, D-464, D-466, D-468, D-469, D-474, D-478, D-484, D-494, D-497, D-498, D-504, D-505, D-507, D-509, D-510, D-511, D-512, D-519, D-520, D-522, D-524, D-526, D-527, D-528, D-530, D-531, D-533, D-534, D-535, D-536, D-537, D-538, D-539, D-540, D-541, D-543, D-544, D-545, D-550, D-552, D-583, D-586, D-606, D-609, D-610, D-611, D-613,

Index

- D-616, D-618, D-621, D-623, D-626, D-627, D-632, E-4, E-13, E-15, E-25, E-26, F-8, F-11, F-13, F-14, F-17, F-18, F-19, F-20, F-22, G-2, G-16, I-2, I-6, I-8
- Scoping, xxvi, xxvii, xxviii, lxxv, lxxvi, 1-9, 1-11, 1-24, 1-25, 1-30, 6-1, 7-16, 7-17, 9-5, 9-6, 11-19, A-1, A-2, C-1, C-2, C-3, C-4, C-5, C-6, C-7, C-8, D-14, D-35, D-41, D-43, D-56, D-71, D-72, D-76, D-86, D-91, D-92, D-98, D-102, D-123, D-126, D-266, D-286, D-321, D-629
- Seismic, 2-13, 3-15, 4-76, 4-77, 4-85, 4-86, 4-87, 4-107, 4-108, 4-109, B-12, B-14, B-22, D-68, D-95, D-147, D-148, D-183, D-218, D-219, D-238, D-267, D-314, D-331, D-334, D-339, D-341, D-343, D-348, D-349, D-363, D-386, D-387, D-389, D-410, D-421, D-422, D-430, D-442, D-444, D-455, D-457, D-478, D-535, D-544, D-620, D-623, E-22, E-24, F-2, F-3, F-6, F-10, F-11, F-12, F-17, F-20
- Severe accidents, xxxiii, xlvi, xlvii, 2-40, 3-38, 4-72, 4-73, 4-84, 4-85, 4-86, 4-88, 4-89, 4-90, 6-56, 6-57, 6-58, 11-1, 11-19, B-14, D-71, D-104, D-105, D-127, D-144, D-148, D-187, D-190, D-218, D-264, D-265, D-280, D-284, D-286, D-293, D-296, D-297, D-312, D-313, D-314, D-317, D-318, D-319, D-323, D-325, D-326, D-327, D-328, D-329, D-330, D-336, D-337, D-338, D-339, D-340, D-341, D-344, D-346, D-349, D-361, D-375, D-427, D-429, D-436, D-438, D-440, D-442, D-444, D-446, D-461, D-495, D-541, D-616, D-620, D-632, F-2, F-4, F-5, F-7, F-9, F-13, F-17, F-20
- Socioeconomic, xxxiv, xxxv, xxxvi, xlvii, xlix, lix, lx, 3-4, 3-5, 4-6, 4-7, 4-8, 4-9, 4-10, 4-11, 4-12, 4-98, 5-3, 5-8, 5-9, 5-10, 5-11, 5-12, 5-13, 5-14, 5-58, 5-59, 6-12, 6-13, 6-14, 6-15, 6-16, 6-58, 8-2, 8-3, 8-4, 8-6, 9-2, 9-4, 9-5, 11-2, 11-19, D-5, D-23, D-59, D-64, D-107, D-182, D-183, D-184, D-187, D-190, D-192, D-193, D-194, D-195, D-196, D-198, D-204, D-260, D-264, D-293, D-297, D-346, D-462, D-491, D-498
- Solid waste, 3-35, 3-36, 3-37, 5-47, 5-48, 5-62, 6-47, 6-62, 8-5, 8-6, 9-3, 9-5, 11-11, 11-14, D-613, E-7, E-26, E-28
- Spent fuel pool fires, xxiv, xxviii, xxxiii, xlvii, lxxiii, lxxiv, lxxvi, 1-3, 1-25, 4-86, 4-94, 9-2, 9-5, B-14, D-6, D-52, D-67, D-107, D-108, D-113, D-114, D-115, D-131, D-153, D-185, D-265, D-281, D-306, D-314, D-315, D-316, D-317, D-318, D-319, D-325, D-326, D-327, D-328, D-329, D-331, D-333, D-334, D-335, D-337, D-339, D-340, D-341, D-346, D-350, D-351, D-355, D-359, D-360, D-366, D-391, D-405, D-417, D-418, D-419, D-420, D-423, D-424, D-425, D-426, D-427, D-428, D-429, D-431, D-433, D-435, D-436, D-437, D-438, D-439, D-440, D-441, D-442, D-443, D-444, D-445, D-446, D-447, D-448, D-449, D-450, D-451, D-452, D-453, D-494, D-495, D-498, D-514, D-522, D-530, D-533, D-535, D-536, D-538, D-541, D-544, F-1, F-2, F-3, F-4, F-5, F-7, F-9, F-10, F-11, F-12, F-13, F-14, F-15, F-16, F-17, F-18
- Spent fuel pool leaks, xxiii, xxvi, xxxix, xlv, lxxiii, lxxvi, 1-3, 1-25, 3-19, 4-20, 4-23, 4-26, 4-70, 9-2, 9-3, 9-4, 9-6, B-23, B-24, D-6, D-52, D-67, D-78, D-97, D-130, D-131, D-153, D-195, D-196, D-214, D-220, D-221, D-224, D-226, D-227, D-228, D-229, D-230, D-232, D-234, D-237, D-247, D-248, D-386, D-428, D-430, D-454, D-455, D-456, D-457, D-458, D-459, D-460, D-461, D-462, D-463, D-464, D-465, D-466, D-467, D-468, D-469, D-470, D-471, D-472, D-473, D-474, D-475, D-476, D-477, D-478, D-479, D-480, D-481, D-482, D-483, D-484, D-485, D-486, D-488, D-492, D-

- 493, D-514, E-1, E-7, E-8, E-9, E-10, E-11, E-12, E-14, E-15, E-16, E-17, E-18, E-19, E-20, E-21, E-22, E-23, E-26, E-27, E-28
- Stormwater, li, lii, 3-17, 3-21, 3-37, 4-20, 4-22, 4-23, 4-27, 4-34, 4-42, 4-43, 5-6, 5-23, 5-29, 5-30, 6-27, 6-32, 6-35, 11-20, D-223, D-225, D-228, D-232
- Surface water, xxxiv, xxxv, xxxviii, xxxix, xlvii, li, lix, lx, lxiii, 3-11, 3-16, 4-10, 4-22, 4-23, 4-24, 4-25, 4-29, 4-30, 4-31, 4-38, 4-40, 4-80, 4-98, 5-23, 5-24, 5-25, 5-26, 5-28, 5-59, 6-24, 6-25, 6-26, 6-27, 6-28, 6-29, 6-31, 6-34, 6-58, 8-2, 8-3, 8-4, 9-2, 9-5, 11-7, 11-12, 11-20, 11-21, D-127, D-130, D-131, D-188, D-212, D-213, D-214, D-220, D-222, D-223, D-224, D-225, D-226, D-229, D-230, D-231, D-232, D-233, D-235, D-236, D-237, D-238, D-240, D-241, D-242, D-243, D-244, D-245, D-246, D-247, D-254, D-300, D-330, D-334, D-344, D-456, D-457, D-460, D-461, D-462, D-478, D-479, D-480, D-481, D-482, D-485, D-490, D-492, D-609, E-1, E-13, E-14, E-15, E-17, E-18, E-19, E-20, E-21
- T**
- Tax, xxxiv, xxxv, xxxvi, 3-4, 3-6, 3-7, 3-44, 3-49, 4-6, 4-7, 4-8, 4-9, 5-9, 5-10, 5-58, 6-13, 6-14, 6-15, 6-17, 8-6, D-59, D-182, D-183, D-184, D-187, D-191, D-192, D-194, D-195, D-196, D-197, D-497, D-498, D-501, D-510
- Terrorism, xxviii, xlvii, xlviii, lviii, lix, 4-3, 4-91, 4-94, 4-97, 4-98, 4-104, 5-58, 5-59, 8-3, B-22, B-30, B-32, D-5, D-149, D-175, D-265, D-278, D-294, D-297, D-299, D-347, D-350, D-351, D-352, D-353, D-361, D-366, D-367, D-368, D-369, D-392, D-410, D-425, D-449, D-487, D-498, D-514, D-532, D-535, D-536
- Thermal impacts, xl, 3-22, 4-36, 4-39, 4-40, 4-41, 4-42, 4-43, 4-46, 11-20, D-210, D-421
- Threatened species, xli, 3-28, 11-8, 11-20
- Tornado, xlvi, lviii, 3-12, 4-73, 4-76, 4-78, 4-79, 4-80, 4-81, 4-82, 4-84, 4-85, 4-86, 4-87, 4-90, 4-104, 4-107, 5-57, 6-56, 11-15, D-298, D-313, D-314, D-324, D-342, D-346, D-360, D-366, D-387, D-392, D-394, D-410, D-496, D-508, D-535, F-10, G-2
- Transmission lines, 2-2, 2-4, 3-1, 3-15, 3-21, 3-22, 4-15, 4-32, 5-3, 5-6, 6-6, 6-11, 6-32, 6-38, 6-43, 6-54, 11-20, D-183, D-184, D-195
- Tribal, xxvii, 3-8, 3-13, 3-14, 3-32, 4-9, 5-35, 5-36, 11-9, A-1, C-1, C-2, C-3, C-4, C-5, C-11, D-35, D-75, D-100, D-261, D-263, D-265, D-266, D-267, D-529, D-564, D-607
- Tritium, xxxiv, lxiii, 3-19, 3-20, 4-83, 11-20, D-66, D-67, D-137, D-221, D-225, D-228, D-234, D-240, D-277, D-301, D-302, D-454, D-455, D-456, D-475, D-476, D-477, D-481, D-487, D-493, D-618, E-8, E-12, E-19, E-20, E-22, E-23, E-24, E-25, E-26
- U**
- Uranium, xxiv, xxxii, xlviii, 1-17, 1-23, 2-7, 2-8, 2-9, 2-10, 2-11, 2-28, 3-39, 3-40, 6-6, 6-46, 6-52, 6-61, 7-5, 11-3, 11-8, 11-10, 11-14, 11-16, 11-17, 11-21, B-10, B-11, B-12, B-37, D-64, D-65, D-101, D-141, D-170, D-204, D-216, D-269, D-294, D-304, D-307, D-325, D-373, D-399, D-403, D-414, D-415, D-452, D-453, D-491, D-496, D-499, D-517, D-529, D-546, D-617, D-624, F-18, I-1, I-3, I-4, I-8

Index

W

Waste Confidence, xxiii, xxiv, xxvii, xxviii, lxv, lxvi, 1-1, 1-2, 1-3, 1-4, 1-11, 1-12, 1-22, 1-23, 1-24, 1-27, 1-28, 1-30, 1-31, 4-91, 4-100, 7-2, 7-18, 11-21, A-1, A-2, B-1, B-2, B-9, B-11, B-13, B-34, C-1, C-2, C-3, C-4, C-5, C-6, C-7, C-8, C-9, C-10, C-11, C-12, C-13, C-14, C-15, C-16, C-17, C-18, D-1, D-2, D-3, D-4, D-7, D-9, D-10, D-11, D-13, D-14, D-22, D-25, D-30, D-32, D-33, D-34, D-37, D-41, D-42, D-47, D-51, D-52, D-53, D-54, D-56, D-58, D-59, D-61, D-65, D-67, D-73, D-77, D-78, D-80, D-81, D-85, D-89, D-92, D-96, D-107, D-116, D-117, D-154, D-155, D-183, D-199, D-201, D-217, D-249, D-315, D-347, D-370, D-373, D-385, D-409, D-416, D-448, D-512, D-516, D-517, D-522, D-541, D-542, D-547, D-556, D-606, D-608, D-609, D-615, D-624, D-625, D-626, D-627, D-628, D-629, D-630, D-631, E-25

Wetlands, xxxiv, xxxv, lii, 3-2, 3-20, 3-21, 3-24, 3-45, 4-34, 5-27, 5-28, 6-11, 6-31, 6-32, 11-21, D-252

Y

Yucca Mountain, 1-16, 1-20, 1-28, 2-40, 4-72, 4-102, 5-20, 5-61, 5-64, 6-20, 6-42, 6-48, 6-61, 11-21, B-3, B-29, B-30, B-31, B-34, B-35, B-36, B-38, B-40, B-41, C-2, D-4, D-6, D-12, D-28, D-63, D-67, D-90, D-106, D-107, D-125, D-143, D-144, D-171, D-174, D-176, D-177, D-179, D-180, D-202, D-290, D-295, D-370, D-371, D-372, D-375, D-376, D-377, D-378, D-381, D-382, D-384, D-385, D-512, D-519, D-547, D-548, D-549, D-550, D-551, D-604, D-605, D-612, D-614, D-618, D-621

Yucca Mountain EIS, 5-20, 6-20, 6-42, 11-21, B-30, B-31, D-106, D-107, D-125, D-171, D-174, D-176, D-177, D-179, D-180

11.0 Glossary

Accident

See **Design basis accident and severe accident**

Adverse environmental impacts

Impacts that are determined to be harmful to the environment.

Aesthetics (visual resources)

The natural and cultural features of the landscape that can be seen and that contribute to the public's appreciative enjoyment of the environment. Visual resource or aesthetic impacts are generally defined in terms of a project's physical characteristics and potential visibility and the extent to which the project's presence would change the perceived visual character and quality of the environment in which it would be located.

Aging management (activity)

An application of either the aging management program or time-limited aging analysis to provide reasonable assurance that the intended functions of structures, systems, and components of spent fuel storage facilities are maintained during the license period of extended operation.

Aging management program

A program conducted by the licensee or certificate of compliance holder for addressing aging effects that may include prevention, mitigation, condition monitoring, and performance monitoring in accordance with the requirements of Title 10 of the *Code of Federal Regulations* (CFR) Parts 50, 54, and 72.

Air quality

Assessment of the health-related and visual characteristics of the air, often derived from quantitative measurements of the concentrations of specific injurious or contaminating substances. Air quality standards are the prescribed levels of substances in the outside air that cannot be exceeded during a specific time in a specified area.

Alternative

Reasonable means, other than the proposed action, by which to achieve the same purpose and satisfy the same need as the proposed action.

Aquatic biota

An organism that lives in, on, or near the water, including fish, macroinvertebrates, zooplankton, phytoplankton, macrophytes, and aquatic vegetation.

Aquatic ecosystem types:

- **Freshwater**

Waters that contain a salt concentration or salinity of less than 0.5 parts per thousand (ppt) or 0.05 percent.

- *Lentic*: Stagnant or slow-flowing fresh water (e.g., lakes and ponds).
- *Lotic*: Flowing fresh water with a measurable velocity (e.g., rivers and streams).

- **Marine**

Waters that contain a salt concentration of about 30 ppt (e.g., ocean overlying the continental shelf and associated shores).

- **Estuarine**

Coastal bodies of water where freshwater merges with marine waters. These waterbodies are often semi-enclosed and have a free connection with marine ecosystems (e.g., bays, inlets, lagoons, and ocean-flooded river valleys). Salinity concentrations fluctuate between 0 and 30 ppt, varying spatially and temporally due to location and tidal activity.

Aquifer

An underground layer of permeable, unconsolidated sediments or porous or fractured bedrock that yields usable quantities of water to a well or spring.

Archaeological Resources Protection Act of 1979

A statute which requires Federal permitting for excavation or removal of archaeological resources from public or Native American lands.

As low as (is) reasonably achievable (ALARA)

Making every reasonable effort to maintain exposures to ionizing radiation as far below the dose limits as practical, consistent with the purpose for which the licensed activity is undertaken, taking into account the state of technology, the economics of improvements in relation to state of technology, the economics of improvements in relation to benefits to the public health and safety, and other societal and socioeconomic considerations, and in relation to utilization of nuclear energy and licensed materials in the public interest (see 10 CFR 20.1003).

Bare fuel

Spent fuel rods or assemblies that are separate from or can be loaded into containment systems such as canisters or casks.

Baseline

A quantitative expression of conditions, costs, schedule, or technical progress that constitutes the standard against which to measure the performance of an activity. For this generic environmental impact statement (GEIS), the baseline is the affected environment at the beginning of continued storage, taking into account the environmental impacts during reactor operations.

Biota

The combined flora and fauna of a region.

Boiling water reactor (BWR)

A reactor in which water, used as both coolant and moderator, boils in the core to produce steam, which drives a turbine connected to an electrical generator, thereby producing electricity.

Burnup

A measure of how much energy is extracted from the nuclear fuel before it is removed from the core. Its units are gigawatt-days (GWd) per tonne of uranium (MTU) in fresh fuel. Spent fuel is considered to have low burnup if the burnup is less than 45 GWd/MTU.

Candidate species

Animal or plant species for which the Fish and Wildlife Service (FWS) or National Marine Fisheries Service (NMFS) has on file sufficient information on vulnerability and threats to support a proposal to list it as endangered or threatened.

Canister

A large rugged cylinder containing one to six dozen spent fuel assemblies. A canister, typically made of a corrosion-resistant metal, is filled with inert gas and bolted or welded closed. The sealed canister is typically emplaced inside an outer shell of steel, concrete, lead, or other material as part of a dry cask storage system.

Cask

A heavily shielded container used for the dry storage or shipment (or both) of radioactive materials such as spent nuclear fuel (spent fuel) or other high-level radioactive waste. Casks are often made from lead, concrete, or steel. Casks must meet regulatory requirements and are not intended for long-term disposal in a repository.

Cladding

The thin-walled metal tube that forms the outer jacket of a nuclear fuel rod. It prevents corrosion of the fuel by the coolant within the nuclear reactor and the release of fission products into the coolant. Stainless steel and zirconium alloys are common cladding materials.

Glossary

Clean Air Act (CAA)

Establishes national ambient air quality standards and requires facilities to comply with emission limits or reduction limits stipulated in State Implementation Plans (SIPs). Under this Act, construction and operating permits, as well as reviews of new stationary sources and major modifications to existing sources, are required. This statute also prohibits the Federal government from approving actions that do not conform to SIPs.

Climate change (Global climate change)

Changes in the Earth's surface temperature thought to be caused by the greenhouse effect and responsible for changes in global climate patterns. The greenhouse effect is the trapping and buildup of heat in the atmosphere (troposphere) near the Earth's surface. Some of the heat flowing back toward space from the Earth's surface is absorbed by water vapor, carbon dioxide, ozone, and certain other gases in the atmosphere and then reradiated back toward the Earth's surface.

Closed-cycle cooling

In this type of cooling-water system, the cooling water is recirculated through the condenser after the waste heat is removed by dissipation to the atmosphere, usually by circulating the water through large cooling towers constructed for that purpose.

Code of Federal Regulations (CFR)

The codification of the general and permanent rules published in the *Federal Register* by the executive departments and agencies of the Federal government. It is divided into 50 titles that represent broad areas subject to Federal regulation. Each volume of the CFR is updated once each calendar year and is issued on a quarterly basis.

Committed dose equivalent

The dose equivalent to organs or tissues of reference that will be received from an intake of radioactive material by an individual during the 50-year period following the uptake.

Committed effective dose equivalent (CEDE)

The sum of the products of the weighting factors for body organs or tissues that are irradiated and the committed dose equivalent to these organs or tissues.

Compact

A group of two or more states formed to dispose of low-level radioactive waste on a regional basis. The Low-Level Radioactive Waste Policy Act of 1980 encouraged states to form compacts to ensure continuing low-level waste disposal capacity. As of December 2000, 44 states have formed 10 compacts.

Confinement

The ability of a storage system to retain radioactive material, including gases and particulates, within the system.

Consolidated storage

A spent fuel storage facility designed to store spent fuel produced from multiple nuclear power plants.

Continued storage

The time period during which spent fuel is stored after the end of the licensed life for operations of a nuclear reactor and prior to disposal in a permanent repository.

Cooling system (Reactor)

System used to remove energy from the reactor core and transfer that energy either directly or indirectly to the steam turbine.

Cooling system (Spent Fuel)

System used to remove energy from spent fuel pools that typically consists of pumps to circulate cooling water through the system, a purification system of filters and a demineralizer, and a heat exchanger (which transfers the heat from the spent fuel pool cooling system to the service-water system or its equivalent).

Core damage frequency

An expression of the likelihood that, given the way a reactor is designed and operated, an accident could cause the fuel in the reactor to be damaged.

Corrective action

Measures taken to rectify conditions adverse to quality, safety, or compliance with NRC requirements.

Council on Environmental Quality (CEQ)

Established by the National Environmental Policy Act (NEPA). Council on Environmental Quality regulations (40 CFR Parts 1500–1508) describe the process for implementing NEPA, including preparation of environmental assessments and environmental impact statements, and the timing and extent of public participation. As an independent regulatory body, the NRC's policy is to take account of the regulations of the Council on Environmental Quality published November 29, 1978 (43 FR 55978-56007) voluntarily, to the extent applicable.

Critical habitat

Specific geographic areas, whether occupied by a listed species or not, that are essential for its conservation and that have been formally designated by rule published in the *Federal Register*.

Glossary

Criticality

The normal operating condition of a reactor, in which nuclear fuel sustains a fission chain reaction. A reactor achieves criticality when each fission event releases a sufficient number of neutrons to sustain an ongoing series of reactions. Nuclear fuel that is in storage or being handled is required to avoid criticality, or remain “subcritical.”

Cultural resource (historic resource)

The remains of past human activity and include prehistoric era and historic era archaeological sites, historic districts, buildings, or objects with an associated historical, cultural, archaeological, architectural, community, or aesthetic value. Historic and cultural resources also include traditional cultural properties that are important to a living community of people for maintaining their culture.

Decommissioning

The process of safely closing a nuclear power plant (or other facility where nuclear materials are handled) to retire it from service after its useful life has ended. This process primarily involves decontaminating the facility to reduce residual radioactivity and then releasing the property for unrestricted use (see 10 CFR 20.1003) or (under certain conditions) restricted use. This often includes dismantling the facility or dedicating it to other purposes. Decommissioning begins after the nuclear fuel, coolant, and radioactive waste are removed from the reactor.

Decommissioning GEIS (NUREG-0586)

A generic environmental evaluation of the scope and impact of environmental effects associated with the decommissioning of nuclear power reactors as residual radioactivity at the site is reduced to levels that allow for termination of the NRC license.

DECON

A method of decommissioning in which the equipment, structures, and portions of a facility and site containing radioactive contaminants are removed and safety buried in a low-level radioactive waste landfill or decontaminated to a level that permits the property to be released for unrestricted use shortly after cessation of operations.

Deep dose equivalent

The dose equivalent at a tissue depth of 1 cm (0.39 in.); applies to external whole-body exposure.

Department of Energy (DOE)

The DOE is a cabinet-level agency that has both important energy- and national security-related missions. DOE officials oversee the laboratories that were once primarily responsible for creating nuclear weapons, along with implementing policies geared toward strengthening the United States' sources of energy. The DOE carries out policies ranging from nuclear power to fossil fuels to alternative energy sources.

Design basis events

Conditions of normal operation, design basis accidents, external events, and natural phenomena, for which the plant must be designed to ensure the capability to prevent or mitigate the consequences of accidents that could result in potential offsite exposures.

Design basis accident

A postulated accident that a nuclear facility must be designed and built to withstand without loss to the systems, structures, and components necessary to ensure public health and safety.

Disposal

The act of placing unwanted materials in an area with the intent of not recovering in the future.

Dose

A general term which may be used to refer to the amount of energy absorbed by an object or person per unit mass. Known as the “absorbed dose,” this reflects the amount of energy that ionizing radiation sources deposit in materials through which they pass, and is measured in units of radiation-absorbed dose (rad). The related international system unit is the gray (Gy), where 1 Gy is equivalent to 100 rad. See also, **total effective dose equivalent (TEDE)**, **committed effective dose equivalent (CEDE)**, and **deep dose equivalent**.

Dose equivalent

The product of the absorbed dose in tissue, quality factor, and all other modifying factors at the location of interest. The units of dose equivalent are the rem and Sievert (Sv).

Dry cask storage

A method for storing spent fuel in special containers known as casks. After fuel has been cooled in a spent fuel pool for at least 1 year, dry cask storage allows approximately one to six dozen spent fuel assemblies to be sealed in casks and surrounded by inert gas.

Dry transfer system (DTS)

A facility that enables retrieval of spent fuel from dry cask storage for inspection or repackaging without the need to return the spent fuel to a pool. Proposed designs for dry transfer systems consist of concrete and steel structures designed to provide both confinement and shielding during fuel transfer operations.

Effective dose equivalent

The sum of the products of the dose equivalent to the organ or tissue and the weighting factors applicable to each of the body organs or tissues that are irradiated.

Effluent

A discharge of gas or liquid into the environment, partially or completely treated or in its natural state. This term typically refers to wastes discharged into surface waters.

Glossary

Electromagnetic fields

The field of energy resulting from the movement of alternating electric current (AC) along the path of a conductor, composed of both electrical and magnetic components and existing in the immediate vicinity of, and surrounding, the electric conductor. Electromagnetic fields exist in both high-voltage electric transmission power lines and in low-voltage electric conductors in homes and appliances.

Endangered species

Animal or plant species in danger of extinction throughout all or a significant portion of its range.

Endangered Species Act of 1973 (ESA)

Requires consultation with the FWS and/or the NMFS to determine whether endangered or threatened species or their habitats will be affected by a proposed activity and what, if any, mitigation measures are needed to address the impacts.

ENTOMB

A method of decommissioning nuclear facilities in which radioactive contaminants are encased in a structurally long-lived material, such as concrete. The entombment structure is appropriately maintained and continued surveillance is carried out until the radioactivity decays to a level permitting unrestricted release of the property.

Enrichment

Increasing the proportion of uranium atoms that can be “split” by fission to release energy (usually in the form of heat) that can be used to produce electricity.

Entrainment

The incorporation of all life stages of fish and shellfish with intake water flow entering and passing through a cooling-water-intake structure and into a cooling-water system (40 CFR 125.83).

Environmental assessment (EA)

A concise public document that a Federal agency prepares under NEPA to provide sufficient evidence and analysis to determine whether a proposed action requires preparation of an environmental impact statement or whether a Finding of No Significant Impact can be issued. An EA must include brief discussions on the need for the proposed action and the environmental impacts of the proposed action and the no-action alternative.

Environmental impact statement (EIS)

A document required of Federal agencies by NEPA for major proposals or legislation that will or could significantly affect the environment. The primary purpose of an EIS is to serve as an action-forcing device to ensure that the policies and goals defined in the Act are infused into the ongoing programs and actions of the Federal government. An EIS provides full and fair

discussion of significant environmental impacts and shall inform decision-makers and the public of the reasonable alternatives which would avoid or minimize adverse impacts or enhance the quality of the human environment. The EIS should be used by Federal officials in conjunction with other relevant material to plan actions and make decisions.

Environmental justice

The fair treatment of people of all races, cultures, incomes, and educational levels with respect to the development, implementation, and enforcement of environmental laws, regulations, and policies.

Environmental Protection Agency (EPA)

A Federal agency, created for the purpose of promoting human health by protecting the nation's air, water, and soil from harmful pollution by enforcing environmental regulations based on laws passed by Congress. The agency performs environmental assessments, conducts research, and provides education. It has the responsibility of maintaining and enforcing national standards under a variety of environmental laws (e.g., Clean Air Act), in consultation with State, Tribal, and local governments. It delegates some permitting, monitoring, and enforcement responsibility to States and Native American Tribes. EPA enforcement powers include fines, sanctions, and other measures. The agency also works with industries and all levels of government in a wide variety of voluntary pollution prevention programs and energy conservation efforts.

EPA Air Quality Designations

- **Attainment:** An EPA air quality designation for any area that meets the national primary or secondary ambient air quality standard for the pollutant.
- **Nonattainment:** An EPA air quality designation for any area that does not meet (or that contributes to ambient air quality in a nearby area that does not meet) the national primary or secondary ambient air quality standard for the pollutant.
- **Unclassifiable:** Any area that cannot be classified on the basis of available information as meeting or not meeting the national primary or secondary ambient air quality standard for the pollutant.

Essential fish habitat (EFH)

Those waters and substrates needed by Federally managed marine and anadromous fish for spawning, breeding, feeding, or growth to maturity.

Fish and Wildlife Service (FWS)

A Federal agency within the U.S. Department of the Interior responsible for the management of fish, wildlife, and natural habitats. The FWS's major responsibilities are for migratory birds, endangered species, certain marine mammals, and freshwater and anadromous fish.

Glossary

Fuel assembly (fuel bundle)

A structured group of fuel rods, which are long, slender, metal tubes containing pellets of fissionable material, which provide fuel for nuclear reactors. Depending on the design, each reactor vessel may have dozens of fuel assemblies (also known as fuel bundles), each of which may contain 200 or more fuel rods.

Fuel cycle

The series of steps involved in supplying fuel for nuclear power reactors include the following:

- uranium recovery to extract (or mine) uranium ore, and concentrate (or mill) the ore to produce "yellowcake",
- conversion of yellowcake into uranium hexafluoride (UF₆),
- enrichment to increase the concentration of uranium-235 (U-235) in UF₆,
- fuel fabrication to convert enriched UF₆ into fuel for nuclear reactors,
- use of the fuel in reactors (nuclear power, research, or naval propulsion),
- interim storage of spent fuel,
- reprocessing of high-level waste to recover the fissionable material remaining in the spent fuel (currently not done in the United States), and
- final disposition (disposal) of high-level waste.

The NRC regulates these processes, as well as the fabrication of mixed oxide nuclear fuel, which is a combination of uranium and plutonium oxides.

Fuel reprocessing (recycling)

The processing of reactor fuel to separate the unused fissionable material from waste material. Reprocessing extracts isotopes from spent fuel so they can be used again as reactor fuel.

Fugitive dust

Particulate air pollution released to the ambient air from ground-disturbing activities related to construction, manufacturing, or transportation (i.e., the discharges are not released through a confined stream such as a stack, chimney, vent, or other functionally equivalent opening). Specific activities that generate fugitive dust include, but are not limited to, land-clearing operations, travel of vehicles on disturbed land or unpaved access roads, or onsite roads.

Generic environmental impact statement (GEIS)

In general, a GEIS assesses the scope and impact of environmental effects that would be associated with an action at numerous sites. This GEIS assesses the scope and impact of environmental effects associated with the continued storage of spent fuel after the licensed life of a nuclear power reactor.

Geologic repository

An excavated, underground facility that is designed, constructed, and operated for safe and secure permanent disposal of high-level radioactive waste. A geologic repository uses an engineered barrier system and a portion of the site's natural geology, hydrology, and geochemical systems to isolate the radioactivity of the waste.

Greater-than-class-C waste (GTCC)

GTCC waste means low-level radioactive waste that exceeds the concentration limits of radionuclides established for Class C waste in 10 CFR 61.55.

Greenhouse gases

Gases that trap heat in the atmosphere. The most common greenhouse gases are carbon dioxide, methane, nitrous oxide, and fluorinated gases. Greenhouse gases contribute to global climate change.

Groundwater

The water found beneath the Earth's surface, usually in porous rock formations (aquifers) or in a zone of saturation, which may supply wells and springs, as well as base flow to major streams and rivers. Generally, it refers to all water contained in the ground.

Habitat

Area in which a plant or animal lives and reproduces.

Half-life

The time in which one-half of the atoms of a particular radioactive substance disintegrate into another nuclear form. Measured half-lives vary from millionths of a second to billions of years. Also called physical or radiological half-life.

Hardened onsite storage (HOSS)

A term referring to a proposed strategy to enhance the safety and security of spent fuel storage in dry casks or vault systems. As described by proponents, HOSS is the preferred end-point of a process that involves moving spent fuel from dense-packed cooling pools and into dry storage systems at reactor sites. The HOSS concept adds berms to conventional dry storage systems with the intent of offering greater resistance to potential terrorist attacks using aircraft or conventional weapons.

Hazardous waste

A solid waste or combination of solid wastes that, because of its quantity, concentration, or physical, chemical, or infectious characteristics, may (1) cause or significantly contribute to an increase in mortality or an increase in serious irreversible or incapacitating reversible illness or (2) pose a substantial present or potential hazard to human health or the environment when

Glossary

improperly treated, stored, transported, disposed of, or otherwise managed (as defined in the Resource Conservation and Recovery Act, as amended, Public Law 94-580).

High-level radioactive waste (HLW)

The highly radioactive materials produced as byproducts of fuel reprocessing or of the reactions that occur inside nuclear reactors. HLW includes the following:

- irradiated spent fuel discharged from commercial nuclear power reactors,
- the highly radioactive liquid and solid materials resulting from the reprocessing of spent fuel, which contain fission products in concentration (this includes some reprocessed HLW from defense activities and a small quantity of reprocessed commercial HLW), and
- other highly radioactive materials that the Commission may determine require permanent isolation.

Historic property

Any prehistoric or historic district, site, building, structure, or object included in, or eligible for inclusion in, the *National Register of Historic Places* maintained by the Secretary of the Interior. Historic properties also include artifacts, records, and remains that are related to and located within such properties. The term includes properties of traditional religious and cultural importance to an Indian Tribe or Native Hawaiian organization that meet the *National Register* criteria (see also 36 CFR 800.16(l)(1)).

Hydrology

The study of water that considers its occurrence, properties distribution, circulation, and transport and includes groundwater, surface water, and rainfall.

Impingement

The entrapment of all life stages of fish and shellfish on the outer part of an intake structure or against a screening device during periods of water withdrawal (40 CFR 125.83).

Independent spent fuel storage installation (ISFSI)

A complex designed and constructed for the interim storage of spent fuel; solid, reactor-related, GTCC waste; and other associated radioactive materials. A spent fuel storage facility may be considered independent, even if it is located on the site of another NRC-licensed facility. The most common design for an ISFSI, at this time, is a concrete pad with dry casks containing spent fuel bundles. ISFSIs are used by operating plants that require increased spent fuel storage capability because their spent fuel pools are nearly full.

Institutional controls

In the context of continued storage of spent fuel, institutional controls refers to actions taken by an institution (e.g., a government, corporation, or other entity) for long-term site management

and control of radioactive waste. Institutional controls at storage facilities include controlling site access, implementation of aging management programs, performing maintenance or remedial actions, monitoring, and controlling or remediating releases.

Interim storage

The storage of spent fuel, typically in dry cask storage systems, from the time it is removed from a spent fuel pool until disposal in a geologic repository.

Isotope

Two or more forms (or atomic configurations) of a given element that have identical atomic numbers (the same number of protons in their nuclei) and the same or very similar chemical properties but different atomic masses (different numbers of neutrons in their nuclei) and distinct physical properties. Thus, carbon-12, carbon-13, and carbon-14 are isotopes of the element carbon, and the numbers denote the approximate atomic masses. Among their distinct physical properties, some isotopes (known as radioisotopes) are radioactive because their nuclei emit radiation as they strive toward a more stable nuclear configuration. For example, carbon-12 and carbon-13 are stable, but carbon-14 is unstable and radioactive.

License amendment

Changes to the operating license for a nuclear power plant such as a change to the technical specifications, system modifications, or changes to operating procedures that require approval by the NRC before they can be implemented by a licensee.

License renewal

Renewal of the operating license of a nuclear power plant or ISFSI.

License Renewal GEIS (NUREG-1437)

A generic environmental evaluation of the scope and impact of environmental effects associated with the continued operation of nuclear power plants during the license renewal term.

Licensee

A company, organization, institution, or other entity to which the NRC or an Agreement State has granted a general license or specific license to construct or operate a nuclear facility, or to receive, possess, use, transfer, or dispose of source material, byproduct material, or special nuclear material.

Licensed material

Source material, byproduct material, or special nuclear material that is received, possessed, used, transferred, or disposed of under a general license or specific license issued by the NRC or Agreement States.

Glossary

Licensing basis

The aggregate documents or technical criteria that provides the basis upon which the NRC issues a license to construct or operate a nuclear facility; to conduct operations involving the emission of radiation; or to receive, possess, use, transfer, or dispose of source material, byproduct material, or special nuclear material.

Low-income populations

Persons whose average family income is below the poverty line. The poverty line takes into account family size and age of individuals in the family. In 2013, the poverty line for a family of four with two children below the age of 18 was \$23,624. For any family below the poverty line, all family members are considered to be below the poverty line.

Low-level waste (LLW)

A general term for a wide range of items that have become contaminated with radioactive material or have become radioactive through exposure to neutron radiation. The radioactivity in these wastes can range from just above natural background levels to much higher levels, such as seen in parts from inside the reactor vessel in a nuclear power reactor.

Mitigation

A method or process by which impacts from actions can be made less injurious to the environment through appropriate protective measures.

Mixed oxide fuel (MOX)

A type of nuclear reactor fuel (often called "MOX") that contains plutonium oxide mixed with either natural or depleted uranium oxide, in ceramic pellet form. Using plutonium reduces the amount of highly enriched uranium needed to produce a controlled reaction in commercial light-water reactors.

Mixed waste

Material that contains two components: LLW and hazardous waste, as defined in EPA regulations.

Monitoring

Periodic or continuous processes and activities necessary to assess the status of the environment that is typically part of a structured program required or approved by a regulatory agency responsible for protection of human health and safety and the environment.

Municipal solid waste

Residential solid waste and some nonhazardous commercial, institutional, and industrial wastes.

National Ambient Air Quality Standards (NAAQS)

Air quality standards established by the Clean Air Act, as amended. The primary NAAQS specify maximum outdoor air concentrations of criteria pollutants that would protect the public health within an adequate margin of safety. The secondary NAAQS specify maximum concentrations that would protect the public welfare from any known or anticipated adverse effects of a pollutant.

National Environmental Policy Act of 1969 (NEPA)

An Act requiring Federal agencies to prepare a detailed statement on the environmental impacts of their proposed major actions that may significantly affect the quality of the human environment.

National Historical Preservation Act of 1966 (NHPA)

Section 106 of the NHPA addresses the impacts of Federal undertakings on historic properties. Undertakings are defined in the NHPA as any project or activity that is funded or under the direct jurisdiction of a Federal agency, or any project or activity that requires a Federal permit, license, or approval (see also 36 CFR 800.16(y)).

National Marine Fisheries Service (NMFS)

A Federal agency responsible for the stewardship and management of the nation's living marine resources and their habitat within the United States' Exclusive Economic Zone, which extends seaward 200 nautical miles from the coastline (about 370 kilometers). The NMFS is a division of the National Oceanic and Atmospheric Administration within the Department of Commerce.

Natural phenomena

Events that occur in nature such as earthquakes, tornadoes, hurricanes, floods, and tsunamis.

No-action alternative

In general, the no-action alternative of an EIS assumes that the proposed action would not take place; the resulting environmental impacts from taking no action would be compared with the impacts of permitting the proposed action or an alternative action. For this GEIS, the no-action alternative represents a decision by the Nuclear Regulatory Commission to not proceed with a rulemaking that codifies the impact determinations in this GEIS.

Nonradioactive nonhazardous waste

Waste that is neither radioactive nor hazardous and typically deposited in a landfill.

Nuclear fuel

Fissionable material that has been enriched to a composition that will support a self-sustaining fission chain reaction when used to fuel a nuclear reactor, thereby producing energy (usually in the form of heat or useful radiation) for use in other processes.

Glossary

Nuclear power plant

A facility that uses a nuclear reactor to generate electricity.

Nuclear reactor

A device in which nuclear fission may be sustained and controlled in a self-supporting nuclear reaction. There are many types of reactors, but all incorporate certain features, including fissionable material or fuel, a moderating material (unless the reactor is operated on fast neutrons), a reflector to conserve escaping neutrons, provisions of removal of heat, measuring and controlling instruments, and protective devices. The reactor is the principal component of a nuclear power plant.

Nuclear waste

A subset of radioactive waste that includes unusable byproducts produced during the various stages of the nuclear fuel cycle, including recovery (or extraction), conversion, and enrichment of uranium; fuel fabrication; and use of the fuel in nuclear reactors. Specifically, these stages produce a variety of nuclear waste materials, including uranium mill tailings, depleted uranium, and spent (depleted) fuel, all of which are regulated by the NRC. By contrast, "radioactive waste" is a broader term, which includes all wastes that contain radioactivity, regardless of how they are produced.

Occupational dose

The dose received by an individual in the course of employment in which the individual's assigned duties involves exposure to radiation or to radioactive material. Occupational dose is restricted by NRC regulations under 10 CFR Part 20, Subpart C.

Occupational Safety and Health Administration (OSHA)

A Federal agency in the Department of Labor whose mission is to prevent work-related injuries, illnesses, and deaths. Congress created OSHA under the Occupational Safety and Health Act on December 29, 1970.

Once-through cooling system

In this cooling system, circulating water for condenser cooling is obtained from an adjacent body of water, such as a lake or river, passed through the condenser tubes, and returned directly at a higher temperature to the adjacent body of water.

Population dose

Dose received collectively by a population.

Power block

The buildings and components directly involved in generating electricity at a power plant. At a nuclear power plant, the components of the power block vary with the reactor design, but always include the reactor and turbine building, and usually include several other buildings that

house access, reactor auxiliary, safeguards, waste processing, or other nuclear generation support functions.

Pressurized water reactor (PWR)

A power reactor in which thermal energy is transferred from the core to a heat exchanger by high-temperature water kept under high pressure in the primary system. Steam is generated in the heat exchanger in a secondary circuit.

Private Fuel Storage Facility (PFSF)

A proposed away-from-reactor ISFSI on the Reservation of the Skull Valley Band of Goshute Indians in Tooele County, Utah. The NRC analyzed the environmental impacts of constructing and operating the PFSF in NUREG-1714.

Probability weighted consequence

A measure of the severity of an environmental impact or accident that accounts for both the likelihood that the event occurs and the consequences if the event does occur. Where both the likelihood and consequences (e.g., cumulative dose, cost to the local economy, or area of land contamination) can be quantified, it is the product of these two factors.

Proposed species

Animal or plant species that is proposed for inclusion under Section 4 of the Endangered Species Act.

Radiation (ionizing radiation)

Alpha particles, beta particles, gamma rays, x-rays, neutrons, high-speed electrons, high-speed protons, and other particles capable of producing ions, which are atoms or molecules with a net electric charge due to the loss or gain of one or more electrons. Radiation, as used in the NRC's standards for radiation protection, 10 CFR Part 20, does not include natural sources of radiation such as soil or the sun or non-ionizing radiation, such as radio- or microwaves, or visible, infrared, or ultraviolet light (see also 10 CFR 20.1003).

Radioactivity

The property possessed by some elements (e.g., uranium) of spontaneously emitting energy in the form of radiation as a result of the decay (or disintegration) of an unstable atom.

Radioactivity is also the term used to describe the rate at which radioactive material emits radiation. Radioactivity is measured in curies (Ci) and becquerels (Bq).

Radioisotope (radionuclide)

An unstable isotope of an element that decays or disintegrates spontaneously, emitting radiation. Approximately 5,000 natural and artificial radioisotopes have been identified.

Glossary

Refurbishment

Repair or replacement of spent fuel storage systems, structures, and components.

Remediation

The restoration of a site by removal of pollution or contamination from the site environment, consistent with regulatory standards, for the protection of public health and safety and the environment.

Repackaging

Replacement of the canister and/or cask which houses spent fuel assemblies.

Repository

See **Geologic repository**.

Reprocessing

See **Fuel reprocessing**.

Risk

The combined probability of an accident with the consequences of that accident. In other words, the NRC examines the following questions: (1) What can go wrong? (2) How likely is it? (3) What are the consequences? Where both the likelihood and consequences can be quantified, it is the product of the likelihood and consequences. See also **Probability weighted consequence**. More information can be found at <http://www.nrc.gov/aboutnrc/regulatory/risk-informed.html>.

Risk-informed regulation

An approach to regulation taken by the NRC, which is guided by an assessment of safety significance or relative risk. This approach ensures that the regulatory burden imposed by an individual regulation or process is appropriate to its importance in protecting the health and safety of the public and the environment.

Risk-significant

"Risk-significant" can refer to a facility's system, structure, component, or accident sequence that exceeds a predetermined limit for contributing to the risk associated with the facility. The term also describes a level of risk exceeding a predetermined "significance" level.

Rulemaking

The process by which NRC formulates, amends, or repeals regulations.

Safeguards

The use of material control and accounting programs to verify that all special nuclear material is properly controlled and accounted for, as well as the physical protection (or physical security)

equipment and security forces. Requirements for physical protection of plants and materials are found in 10 CFR Parts 37 and 73.

Safety-related

Systems, structures, components, procedures, and controls (of a facility or process) that are relied upon to remain functional during and following design basis events. Their functionality ensures that key regulatory criteria, such as levels of radioactivity released, are met.

SAFSTOR

A method of decommissioning in which a nuclear facility is placed and maintained in a condition that allows the facility to be safely stored and subsequently decontaminated (deferred decontamination) to levels that permit release for unrestricted use.

Scoping

An early and open process for determining the scope of issues to be addressed and for identifying the significant issues related to a proposed action. During scoping, an agency will solicit stakeholder input.

Severe accident (beyond-design-basis accident)

Accidents that may challenge safety systems at a level much higher than expected. See also **Design basis accident**.

Shielding

Any material or obstruction that absorbs radiation and thus tends to protect personnel or materials from the effects of ionizing radiation. Shielding also refers to the resulting ability of a system to limit the dose rate at designated locations to acceptable regulatory limits.

Small modular reactors

Nuclear power plants that are smaller in size (e.g., 300 MW(e)) than current generation baseload plants (1,000 MW(e) or higher). These compactly designed reactors are factory-fabricated and can be transported by truck or rail to a nuclear power site.

Socioeconomic

Social and economic characteristics of a human population. Includes both the social impacts of economic activity and the economic impacts of social activity.

Spent fuel (spent nuclear fuel)

Nuclear reactor fuel that has been removed from a nuclear reactor because it can no longer sustain power production for economic or other reasons.

Glossary

Spent fuel pool

An underwater storage and cooling facility for spent fuel assemblies that have been removed from a reactor.

Stormwater

Stormwater runoff, snowmelt runoff, and surface runoff and drainage.

Surface water

Water on the Earth's surface that is directly exposed to the atmosphere, as distinguished from water in the ground (i.e., groundwater).

Terrestrial

Belonging to or living on land.

Thermal impacts

Impacts to the environment, typically aquatic ecosystems, that result from the release of heat energy.

Threatened species

Animal or plant species likely to become endangered within the foreseeable future throughout all or a significant portion of its range. Requirements for declaring a species threatened are contained in the Endangered Species Act.

Total effective dose equivalent (TEDE)

Sum of the effective dose equivalent (for external exposure) and the CEDE (for internal exposure).

Transmission line

A set of conductors, insulators, supporting structures, and associated equipment used to move large quantities of power at high voltage, usually over long distances between a generating or receiving point and major substations or delivery points.

Tritium

A radioactive isotope of hydrogen with one proton and two neutrons. It decays by beta emission, which is the emission of a very low energy beta particle, and transforms to stable, nonradioactive helium. It has a radioactive half-life of about 12.5 years. Water containing tritium is normally released from nuclear power plants under controlled, monitored conditions that the NRC mandates to protect public health and safety. The NRC evaluates abnormal releases of tritium-contaminated water. More information about tritium from nuclear power plants can be found at <http://www.nrc.gov/reading-rm/docollections/fact-sheets/tritium-radiationfs.html>.

Uranium

A radioactive element with the atomic number 92 and, as found in natural ores, an atomic weight of approximately 238. The two principal natural isotopes are uranium-235 (0.7 percent of natural uranium) and uranium-238 (99.3 percent of natural uranium). Natural uranium also includes a minute amount of uranium-234. Uranium-235 is the primary isotope used to produce a chain reaction in a nuclear power reactor. Natural uranium must be processed, or enriched, to increase the concentration of uranium-235, to be used as fuel for a nuclear power reactor.

Waste classification (classes of waste)

Classification of LLW according to its radiological hazard. The classes include Class A, B, and C, with Class A being the least hazardous and accounting for 96 percent of LLW. As the waste class and hazard increase, the regulations established by the NRC require progressively greater controls to protect the health and safety of the public and the environment.

Waste Confidence

Historically, Waste Confidence has been the NRC's generic determination regarding the safety and environmental impacts of storing spent fuel beyond the licensed life for operations of a nuclear power plant. As part of this rulemaking, the name used for the rule will be changed from "Waste Confidence" to "Continued Storage."

Waste, radioactive

Radioactive materials at the end of a useful life cycle or in a product that is no longer useful and should be properly disposed.

Wetlands

Areas that are inundated or saturated by surface water or groundwater and that typically support vegetation adapted for life in saturated soils. Wetlands generally include swamps, marshes, bogs, and similar areas (e.g., sloughs, potholes, wet meadows, river overflow areas, mudflats, natural ponds).

Yucca Mountain

Yucca Mountain, Nevada, was the DOE's proposed location for a geologic repository for spent fuel and HLW. After the DOE requested to withdraw the application for the Yucca Mountain site in 2010 and the NRC's Atomic Safety and Licensing Board dismissed the proceeding, the U.S. Court of Appeals in 2013 ordered the NRC resume its license review and the Commission complied. Site selection remains an ongoing process.

Yucca Mountain EIS

The environmental review prepared by the DOE that discusses the potential impacts from constructing, operating and monitoring, and eventually closing a geologic repository at Yucca Mountain in southern Nevada for the disposal of spent fuel and HLW.

Appendix A
Scoping Comments

Appendix A

Scoping Comments

In this appendix, the U.S. Nuclear Regulatory Commission (NRC) incorporates, by reference, the *Waste Confidence Generic Environmental Impact Statement Scoping Process Summary Report* (NRC 2013a), which was prepared by the NRC in response to comments received on the scope of the environmental review. The NRC issued the Scoping Summary Report on March 4, 2013.

The Scoping Summary Report is available for public inspection in the NRC Public Document Room, located at One White Flint North, 11555 Rockville Pike, Rockville, Maryland, 20852 or from the NRC's Agencywide Documents Access and Management System (ADAMS). The ADAMS Public Electronic Reading Room is accessible at <http://www.nrc.gov/readingrm/adams/web-based.html>. The Scoping Summary Report is listed under Accession No. ML13060A128. Persons who do not have access to ADAMS or who encounter problems in accessing the documents located in ADAMS should contact the NRC's Public Document Room reference staff by telephone at 1-800-397-4209 or 301-415-4737 or by e-mail at pdr@nrc.gov.

On October 25, 2012, the NRC published in the *Federal Register* a Notice of Intent to prepare an environmental impact statement and conduct scoping, "Consideration of Environmental Impacts of Temporary Storage of Spent Fuel After Cessation of Reactor Operation" (77 FR 65137). The notice described the NRC's intent to prepare a generic environmental impact statement (GEIS) and conduct webcast public scoping meetings and webinars and requested comments on the scope of the GEIS. Through the notice, the NRC invited Federal, Tribal, State, and local governments; organizations; and members of the public to provide comments on the scope of the GEIS no later than January 2, 2013.

During the 70-day scoping period, the NRC held two public webcast scoping meetings and two scoping webinars. The meetings and webinars each began with a slide presentation by NRC, which was followed by a question-and-answer period and a block of time dedicated to listening to and transcribing public scoping comments. The NRC considered all comments received during the scoping meetings and webinars and all written comments submitted in-person at the November 14, 2012 afternoon meeting. Appendix C provides the ADAMS accession numbers for the meeting summaries.

In addition, the NRC received hundreds of written comment letters through mail, fax, and www.regulations.gov (Docket ID NRC-2012-0246) during the comment period. Comments received after the January 2, 2013 closing date were considered where practicable. The NRC

Appendix A

reviewed and considered written comments together with the comments received during the public meetings and webinars. Individual comments each received a unique comment identification code, to ensure that each comment could be tracked, and received a response. Comments were consolidated and categorized according to subject matter or topic. The Scoping Summary Report contains the NRC responses to these grouped comments. Separately, the NRC published a document containing the text of the comments, *Scoping Comments on the Waste Confidence Generic Environmental Impact Statement* (NRC 2013b). This document contains a table that identifies the scoping comments made in each category and provides those scoping comment excerpts organized by scoping comment category.

As a result of the scoping process, the NRC identified and eliminated peripheral issues that are not covered in the GEIS. The Scoping Summary Report provides responses that either discuss why particular topics or concerns are outside the scope of the GEIS or indicates concerns or topics that are in scope and are evaluated in the GEIS.

Further detail regarding scoping, public comments received, and the NRC's responses can be found in the full text of the Scoping Summary Report (NRC 2013a). Comments received on the draft GEIS are included in Appendix D of this GEIS.

References

77 FR 65137. October 25, 2012. "Consideration of Environmental Impacts of Temporary Storage of Spent Fuel After Cessation of Reactor Operation." *Federal Register*. U.S. Nuclear Regulatory Commission, Washington, D.C.

NRC (U.S. Nuclear Regulatory Commission). 2013a. "Waste Confidence Generic Environmental Impact Statement Scoping Process Summary Report." Washington, D.C. Accession No. ML13060A128.

NRC (U.S. Nuclear Regulatory Commission). 2013b. "Scoping Comments on the *Waste Confidence Generic Environmental Impact Statement*." Washington, D.C. Accession No. ML13060A130.

Appendix B

Technical Feasibility of Continued Storage and Repository Availability

Appendix B

Technical Feasibility of Continued Storage and Repository Availability

B.1 Introduction

In this *Generic Environmental Impact Statement for Continued Storage of Spent Nuclear Fuel* (GEIS), the U.S. Nuclear Regulatory Commission (NRC) addresses the environmental impacts of continuing to store spent nuclear fuel (spent fuel) at a reactor site or at an away-from-reactor storage facility, after the end of a reactor's licensed life for operation until final disposition in a geologic repository ("continued storage"). This GEIS provides a regulatory basis for the NRC's proposed amendment to Title 10 of the *Code of Federal Regulations* (CFR) Part 51.

Historically, past Waste Confidence proceedings included a Decision with five findings that addressed technical feasibility of a mined geologic repository, the degree of assurance that disposal would be available by a certain time, and the degree of assurance that spent fuel and commercial high-level waste could be managed safely without significant environmental impacts for a certain period beyond the expiration of plants' operating licenses. Preparation of and reliance upon a GEIS is a fundamental departure from the approach used in past Waste Confidence proceedings. This GEIS acknowledges the uncertainties in the Commission's prediction of repository availability and provides an environmental analysis of three possible storage timeframes. To this end the GEIS considers impacts for three possible timeframes constrained by repository availability, including the impacts from indefinite storage, should a repository never become available.

The NRC's underlying conclusions regarding the technical feasibility of continued storage and a repository continue to undergird its environmental analyses. These underlying conclusions, which are relevant to an analysis of the potential environmental impacts assessed in this GEIS, are discussed as two broad issues in this appendix: the NRC's technical information regarding the availability of a repository for disposal of spent fuel generated in a power reactor (Section B.2) and the technical feasibility of safe storage of spent fuel in an at-reactor or away-from-reactor storage facility until sufficient repository capacity becomes available (Section B.3). These two broad issues were addressed in the five findings contained in the Waste Confidence Decision from past Waste Confidence proceedings; this appendix addresses these issues under two broad topic areas rather than five findings. Section B.4 provides a summary of the conclusions reached in this appendix.

B.2 Repository will be Available to Dispose of Spent Fuel

Based on the analysis below and elsewhere in this GEIS, the NRC believes that the most-likely scenario is that a repository will become available to dispose of spent fuel by the end of the short-term timeframe (within 60 years of the end of a reactor's licensed life for operation). The NRC's belief is based on the resolution of two questions: whether a repository is technically feasible and, if so, how long will it take to site, license, construct, and open a repository. "Technical feasibility" simply means whether a geologic repository is technically possible using existing technology (i.e., without any fundamental breakthroughs in science and technology). If technically feasible, then the question becomes what is a reasonable timeframe for the siting, licensing, construction, and opening of a geologic repository. Both questions are discussed in detail below in Sections B.2.1 (Technical Feasibility of a Repository) and B.2.2 (Availability of a Repository).

B.2.1 Technical Feasibility of a Repository

The Commission has consistently determined that current knowledge and technology support the technical feasibility of deep geologic disposal. In its original 1984 Waste Confidence proceeding, the NRC stated that "[t]he Commission finds that safe disposal of [high-level radioactive waste and spent nuclear fuel] is technically *possible* and that it is achievable using *existing* technology" (49 FR 34658) (emphasis added). The Commission then stated: "Although a repository has not yet been constructed and its safety and environmental acceptability demonstrated, no fundamental breakthrough in science or technology is needed to implement a successful waste disposal program." Although the Commission has conducted Waste Confidence proceedings since 1984, this focal point—whether a fundamental breakthrough in science or technology is needed—continues to guide the Commission's consideration of the feasibility of spent fuel disposal. Since 1984, the technical feasibility of a geological repository has moved significantly beyond a theoretical concept.

Today, the consensus within the scientific and technical community engaged in nuclear waste management is that safe geologic disposal is achievable with currently available technology (see, e.g., Blue Ribbon Commission on America's Nuclear Future [BRC 2012], Section 4.3). Currently, 25 countries, including the United States, are considering disposal of spent or reprocessed nuclear fuel in deep geologic repositories. Repository programs in other countries, which continue to provide additional information useful to the U.S. program, are actively considering crystalline rock, clay, and salt formations as repository host media (IAEA 2005). Many of these programs have researched these geologic media for several decades.

Ongoing research in both the United States and other countries supports a conclusion that geological disposal remains technically feasible and that acceptable sites can be identified. After decades of research into various geological media, no insurmountable technical or scientific problem has emerged to challenge the conclusion that safe disposal of spent fuel and

high-level radioactive waste can be achieved in a mined geologic repository. Over the past two decades, significant progress has been made in the scientific understanding and technological development needed for geologic disposal. There is now a better understanding of the processes that affect the ability of repositories to isolate waste over long periods (e.g., the International Atomic Energy Agency's [IAEA's] *Scientific and Technical Basis for the Geologic Disposal of Radioactive Wastes, Technical Reports Series No. 413* [IAEA 2003a] and Ahn and Apted's *Geological Repository Systems for Safe Disposal of Spent Nuclear Fuels and Radioactive Wastes* [Ahn and Apted 2010]).

Further, the ability to characterize and quantitatively assess the capabilities of geologic and engineered barriers has been repeatedly demonstrated (see the Organisation for Economic Cooperation and Development, Nuclear Energy Agency's *Lessons Learnt from Ten Performance Assessment Studies* [NEA 1997]). In addition, specific sites have been investigated and extensive experience has been gained in underground engineering (see IAEA's *Radioactive Waste Management Studies and Trends, IAEA/WMDB/ST/4* [IAEA 2005] and *The Use of Scientific and Technical Results from Underground Research Laboratory Investigations for the Geologic Disposal of Radioactive Waste* [IAEA 2001]). These advances and others throughout the world (e.g., IAEA's *Joint Convention on Safety of Spent Fuel Management and on Safety of Radioactive Waste Management, INFCIRC/546* [IAEA 1997]) continue to confirm the soundness of the basic concept of deep geologic disposal (IAEA 1997). In the United States, the technical approach for safe high-level radioactive waste disposal has remained unchanged for several decades—a deep geologic repository containing natural barriers to hold canisters of high-level radioactive waste with additional engineered barriers to further retard radionuclide release. Although some elements of this technical approach have changed in response to new knowledge, safe disposal remains feasible with current technology. The recent report by the Blue Ribbon Commission on America's Nuclear Future (BRC 2012) supported geologic disposal by concluding that:

geologic disposal in a mined repository is the most promising and technically accepted option available for safely isolating high-level nuclear wastes for very long periods of time. This view is supported by decades of expert judgment and by a broad international consensus. All other countries with spent fuel and high-level waste disposal programs are pursuing geologic disposal. The United States has many geologic media that are technically suitable for a repository.

In addition, support for the feasibility of geologic disposal can be drawn from experience gained from the review of the U.S. Department of Energy's (DOE's) license application for a high-level nuclear waste repository at Yucca Mountain, Nevada (DOE 2008a). On June 3, 2008, the DOE submitted an application for a construction authorization to the NRC, and on September 8, 2008, the NRC notified DOE that it found the application acceptable for docketing (73 FR 53284) and began its review. DOE subsequently filed a motion with an NRC Atomic Safety and Licensing Board seeking permission to withdraw the license application

Appendix B

(NRC 2010a). In recognition of budgetary limitations, the Commission directed the Atomic Safety and Licensing Board to complete all necessary and appropriate case management activities, and the Atomic Safety and Licensing Board suspended the proceeding. The NRC staff completed three technical review documents (i.e., NRC 2011a,b,c) covering the operational period and the postclosure period (i.e., the period after permanent closure of the repository) and one safety evaluation report on general information (NRC 2010b). The NRC staff's technical review did not identify any issues that would challenge the feasibility of geological disposal as a general matter. However, these technical reports did not include conclusions as to whether or not DOE's proposed Yucca Mountain repository satisfies the Commission's regulations and do not constitute a final judgment or determination of the acceptability of the DOE construction application.

In August 2013, the U.S. Court of Appeals for the District of Columbia Circuit (Court of Appeals) issued a writ of mandamus and directed the NRC to resume the licensing process for DOE's license application. In response, the Commission directed the NRC staff to complete and issue the safety evaluation report associated with the license application (NRC 2013). Currently, the NRC is working on completing its safety review of DOE's license application and plans to publish the remaining volumes of its safety evaluation report by January 2015.

The technical feasibility of a deep geologic repository is further supported by current DOE defense-related activities. The DOE sited and constructed, and since March 1999 has been operating, a deep geologic repository for defense-related transuranic radioactive wastes near Carlsbad, New Mexico. At this site, the DOE has successfully disposed of transuranic waste from nuclear weapons research and testing operations. This Waste Isolation Pilot Plant (WIPP) is located in the Chihuahuan Desert of southeastern New Mexico, approximately 42 km (26 mi) east of Carlsbad. The facility is used to store transuranic waste from nuclear weapons research and testing operations from past defense activities. Project facilities include mined disposal rooms 655 m (2,150 ft) underground.

The NRC recognizes the incident at WIPP on February 14, 2014, which resulted in the release of americium and plutonium from one or more transuranic (TRU) waste containers into the environment. Trace amounts of americium and plutonium are believed to have leaked through unfiltered exhaust ducts and escaped aboveground. No personnel were determined to have received external contamination; however, 21 individuals were identified through bioassay to have initially tested positive for low level amounts of internal contamination. No adverse health impacts have been reported. The DOE has issued a Phase 1 accident report on the incident (DOE 2014). Despite the event, the NRC continues to conclude that a repository is technically feasible.

In January 2013, the DOE released *Strategy for the Management and Disposal of Used Nuclear Fuel and High-Level Radioactive Waste*, a response to the Blue Ribbon Commission on America's Nuclear Future's report (DOE 2013). In this strategy document, DOE presents a

framework for “moving toward a sustainable program to deploy an integrated system capable of transporting, storing, and disposing of [spent] nuclear fuel and high-level radioactive waste from civilian nuclear power generation...” (DOE 2013). This new DOE strategy includes a nuclear waste-management system consisting of a pilot interim storage facility, a larger full-scale interim storage facility, and a geologic repository. U.S. policy remains that geologic disposal is the appropriate long-term solution for disposition of spent fuel and high-level radioactive waste.

Finally, the activities of European countries support the technical feasibility of a deep geologic repository. In late 2012, a Finnish nuclear-waste-management company (Posiva) submitted a construction license application for a geological repository for spent fuel to Finland’s Radiation and Nuclear Safety Authority, and in spring 2011, Swedish nuclear authorities accepted an application from the Swedish Nuclear Fuel and Waste Management Company for permission to build a repository for spent fuel. Based on the national and international research, proposals, and experience with geologic disposal, the NRC concludes that a geologic repository continues to be technically feasible.

B.2.2 Availability of a Repository

Given the consensus that geologic repositories are technically feasible, experience to date is also relevant in determining the timeframe to successfully site, license, construct, and open a repository. Of the 24 countries other than the United States considering disposal of spent or reprocessed nuclear fuel in deep geologic repositories, 10 have established target dates for the availability of a repository.¹ The majority of the 14 countries with no established target date for repository availability rely on centralized interim storage, which may include a protracted period of at-reactor storage before shipment to a centralized facility.

While some countries have struggled with specific implementation issues, the international consensus regarding an approach to disposal in a deep geologic repository and a reasonable timeframe for a repository to become available has not been abandoned.

In 1997, the United Kingdom rejected an application for the construction of a rock characterization facility at Sellafield, leaving the country without a path forward for long-term management or disposal of intermediate-level waste or spent fuel. In 1998, an inquiry by the United Kingdom House of Lords endorsed geologic disposal but specified that public acceptance was required. As a result, the United Kingdom Government embraced a repository plan based on the principles of voluntarism and partnership between communities and

¹ The three countries with target dates that plan direct disposal of spent fuel are: Czech Republic (2050), Finland (2020), and Sweden (2025). The seven countries with target dates for disposal of reprocessed spent fuel and high-level radioactive waste are: Belgium (2035), China (2050), France (2025), Germany (2025), Japan (2030s), Netherlands (2103), and Switzerland (2042).

Appendix B

implementers. This led to the initiation of a national public consultation and major structural reorganization within the United Kingdom program. In 2008, the UK Government called for potential volunteers to host the repository and was expecting the repository would open around 2040 (MRWS 2012). In 2013, the Cumbria County Council voted to withdraw from the United Kingdom process to find a host community for an underground radioactive waste disposal facility and to end the site-selection process in West Cumbria. In responding to the outcome of the votes in West Cumbria, the Secretary of State for Energy and Climate Change published a Written Ministerial Statement on January 31, 2013, that made clear that the United Kingdom Government remains committed to geological disposal for the safe and secure management of higher activity radioactive waste (DECC 2013). In July 2014, the United Kingdom continued to support geological disposal and provided a revised policy framework for implementing geological disposal that favors a voluntarist approach based on working with communities that are willing to participate in the siting process (DECC 2014). The formal process for working with communities is expected to begin in 2016.

In Germany, a large salt dome at Gorleben had been under study since 1977 as a potential spent fuel repository. After suspension of exploration in 2000, Germany resumed exploration of Gorleben as a potential spent fuel repository in 2010. In July 2013, the Site Selection Act became effective in Germany. Currently, a 33-member commission made up of representatives from societal groups, academia, and the German government is preparing proposals for site selection procedures, which are due by the end of 2015.

Initial efforts in France during the 1980s also failed to identify potential repository sites, using solely technical criteria. Failure of these attempts led to the passage of nuclear waste legislation that prescribed 15 years of research. Reports on generic disposal options in clay and granite media were prepared and reviewed by the French Nuclear Safety Authority in 2005. In 2006, the French Parliament passed new legislation designating a single site for deep geologic disposal of intermediate- and high-level radioactive waste. This facility, to be located near the town of Bure in northeastern France, is scheduled to open in 2025, about 34 years after passage of the original Nuclear Waste Law of 1991, and 19 years after site selection. On May 6, 2014, the French National Agency for Radioactive Waste Management (ANDRA) announced the actions it intends to take resulting from recent public debate on geological disposal. ANDRA announced plans for a pilot facility and improvements for greater public involvement. ANDRA anticipates completion of the license application at the end of 2017 and, subject to approvals, construction of the facility could begin in 2020 and a pilot phase could begin in 2025.

In Switzerland, after detailed site investigations in several locations, the Swiss National Cooperative for Radioactive Waste Disposal proposed, in 1993, a deep geologic repository for low- and intermediate-level waste at Wellenberg. In 1998, Swiss authorities found that technical feasibility of the disposal concept had been successfully demonstrated; however, in 2002, a public cantonal referendum rejected the proposed repository. Despite difficulties with public acceptance, Swiss authorities have gathered more than 25 years of high-quality field and

laboratory research and are anticipating constructing and operating a deep geologic repository after 2040, less than 30 years from today. A site selection plan was approved by the Federal Council in 2008 and three geological siting areas were identified by 2011 for deep geological disposal of high-level waste. A second phase is currently underway and involves regional participation and comparative studies with safety as the decision criterion.

In 1998, an independent panel reported to the Governments of Canada and Ontario on its review of Atomic Energy of Canada Ltd.'s concept of geologic disposal (CEAA 1998). The panel concluded that broad public support is necessary in Canada to ensure the acceptability of a concept for managing spent fuel. The panel also found that technical safety is a key part, but only one part, of acceptability. To be considered acceptable in Canada, the panel found that a concept for managing nuclear fuel wastes must (1) have broad public support; (2) be safe from a technical perspective; (3) have been developed within a sound ethical and social assessment framework; (4) have the support of Aboriginal people; (5) be selected after comparison with the risks, costs, and benefits of other options; and (6) be advanced by a stable and trustworthy proponent and overseen by a trustworthy regulator. Resulting legislation mandated a nationwide consultation process and widespread organizational reform.

In 2007, the Government of Canada announced its selection of the Adaptive Phased Management approach and directed the Nuclear Waste Management Organization to take at least 2 years to develop a "collaborative community-driven site-selection process." The Nuclear Waste Management Organization is using this process to open consultations with citizens, communities, Aboriginals, and other interested parties to find a suitable site in a willing host community. Nuclear Waste Management Organization's site-selection process was initiated in May 2010. For financial planning and cost estimation purposes only, the Nuclear Waste Management Organization assumes the availability of a deep geological repository in 2035, 27 years after initiating development of new site-selection criteria, 30 years after embarking on a national public consultation, and 37 years after rejection of the original geologic disposal concept (NWMO 2008). At the end of 2012, 21 communities had expressed interest in learning more about the project (NWMO 2013). As of June 2014, 14 of the initial 21 communities are still actively engaged in the siting process. In particular, four communities are continuing with more detailed analyses having completed preliminary assessments; 10 communities are still in the preliminary assessment phase; and seven communities are no longer being considered in the site selection process.

Repository development programs in Finland and Sweden are further along than in other countries but have taken time to build support from potential host communities. In Finland, preliminary site investigations started in 1986, and detailed characterizations of four locations were performed between 1993 and 2000. In 2001, the Finnish Parliament ratified the government's decision to proceed with a repository project at a chosen site only after the 1999 approval by the municipal council of the host community. In December 2012, Posiva (i.e., the nuclear-waste-management company in Finland) submitted a construction permit application for

Appendix B

a final repository that will hold spent fuel from Finland's nuclear reactors. In June 2014, the Radiation and Nuclear Safety Authority (STUK) in Finland estimated that it can complete its safety assessment report for the construction permit application in January 2015. Finland expects this facility to begin receipt of spent fuel for disposal in 2020, 34 years after the start of preliminary site investigations.

Between 1993 and 2000, Sweden conducted feasibility studies in eight municipalities. One site was found technically unsuitable, and two sites were eliminated by municipal referenda. Three of the remaining five sites were selected for detailed site investigations. Municipalities adjacent to two of these sites agreed to be potential hosts, and one refused. Since 2007, detailed site investigations were conducted at Östhammar and Oskarshamn, both of which already host nuclear power stations. On June 3, 2009, the Swedish Nuclear Fuel and Waste Management Company (SKB) selected the Forsmark site located in the Östhammar municipality for the Swedish spent fuel repository and, in spring 2011, SKB submitted a license application. At the request of the Swedish government, the Nuclear Energy Agency organized an international team to review the SKB license application. In June 2012, the international review team completed its review and report stating: "SKB's post-closure radiological safety analysis report, SR-Site, is sufficient and credible for the licensing decision at hand. SKB's spent fuel disposal programme is a mature programme—at the same time innovative and implementing best practice—capable in principle to fulfil the industrial and safety-related requirements that will be relevant for the next licensing steps" (NEA 2012). In April 2014, the Swedish Radiation Safety Authority, as part of its review process, circulated the license application for comment to other public authorities and environmental organizations. A government decision is expected in 2015. If Swedish authorities authorize construction, the repository could be available for disposal around 2025, about 30 years after feasibility studies began.

In the United States, the DOE is the agency responsible for carrying out the national policy to site and build a repository, which includes designing, constructing, operating, and decommissioning the repository. The time DOE will need to develop a repository site will depend upon a variety of factors, including Congressional action and funding. Public acceptance will also influence the time it will take to implement geologic disposal. The NRC, by contrast, is the agency responsible for reviewing, licensing, and overseeing the construction and operation of the repository.

In 2012, the Blue Ribbon Commission on America's Nuclear Future recommended "prompt efforts to develop one or more geologic disposal facilities" (BRC 2012). In response to the Blue Ribbon Commission's report, the DOE (2013) stated that its "...goal is to have a repository sited by 2026; the site characterized, and the repository designed and licensed by 2042; and the repository constructed and its operations started by 2048." Based on the evaluation of international experience with geologic repository programs—including the issues some countries have overcome—and the affirmation by the Blue Ribbon Commission of the geologic repository approach, the NRC continues to believe that 25 to 35 years is a reasonable period for

repository development (i.e., candidate site selection and characterization, final site selection, licensing review, and initial construction for acceptance of waste).

Although the NRC believes that 25 to 35 years is a reasonable timeframe for repository development, it acknowledges that there is sufficient uncertainty in this estimate that the possibility that more time will be needed cannot be ruled out. International and domestic experience have made it clear that technical knowledge and experience alone are not sufficient to bring about the broad social and political acceptance needed to construct a repository. The time needed to develop a societal and political consensus for a repository could add to the time to site and license a repository or overlap it to some degree.

Because the availability of a repository can be substantially affected by whatever process is employed to achieve a national consensus on repository site selection, and consistent with the decision of the Court of Appeals in *New York v. NRC*, this GEIS offers three timeframes for continued storage that reflect significant differences in the availability of the repository. The short-term timeframe assumes a repository is available 60 years after the end of a reactor's licensed life for operation. The long-term timeframe assumes a repository is not available for an additional 100 years beyond the short-term timeframe, which means a repository would be available 160 years after the end of a reactor's licensed life for operation. In recognition of the uncertainty in reaching a national consensus on repository site selection, the third timeframe assumes that a repository does not become available and the spent fuel continues to be stored indefinitely.

In the 2010 Waste Confidence decision, the Commission assessed the length of time that would be needed to site, license, construct, and open a repository. This analysis moved away from the Commission's historical practice of specifying a "target date" and instead concluded that a repository would be available "when necessary." The Commission's reluctance to select a target date was not indicative of an inability to predict the length of the process for siting, constructing, licensing, and opening a repository, but rather that identification of a specific year as a starting point was uncertain. In sum, based on experience in licensing similarly complex facilities in the United States and national and international experience with repositories already in progress, the NRC concludes a reasonable period of time for the development of a repository is approximately 25 to 35 years.

B.3 Technical Feasibility of Safe Storage

Spent fuel removed from a reactor is initially placed in a spent fuel pool for cooling. After several years (about 5 years for low-burnup fuel and up to 20 years for high-burnup fuel), the spent fuel is sufficiently cooled that it can be placed in dry cask storage assuming current

Appendix B

storage configurations and heat loads.² After the end of a reactor's licensed life for operations, spent fuel is stored in onsite spent fuel pools or in an at-reactor or away-from-reactor dry cask storage system.

Continued storage of spent fuel at at-reactor or away-from-reactor sites will be necessary until a repository is available for permanent disposal. The storage of spent fuel in any combination of storage (spent fuel pools or dry casks) will continue as a licensed activity under regulatory controls and oversight. Nonetheless, the conclusions reached by the NRC in this GEIS regarding the technical feasibility of continued storage do not rely solely on NRC's regulatory framework governing these activities. Rather, these conclusions are also based on NRC's experience with the actual storage of spent fuel under this regulatory framework and the continued application of proven fuel storage methodologies. Continued safe storage of spent fuel requires both the technical feasibility of storage methods and a regulatory framework that provides for monitoring and oversight to address the potential for evolving issues. The technical feasibility of wet storage in spent fuel pools and dry casks is discussed separately in Sections B.3.1 and B.3.2. The regulatory framework applicable to both wet and dry storage is discussed in Section B.3.3. The continuation of the institutional controls necessary to maintain safe storage is discussed in Section B.3.4.

B.3.1 Technical Feasibility of Wet Storage

The technical feasibility of continued storage in spent fuel pools is supported by a number of technical considerations. First, the integrity of spent fuel and cladding within the benign environment of the spent fuel pool's controlled water chemistry is supported by operational experience and a number of scientific studies, some of which are summarized below. Further, the spent fuel pool's robust structural design protects against a range of natural and human-induced challenges, which are discussed in detail in the following sections and in the body of the GEIS.

B.3.1.1 Integrity of Spent Fuel and Cladding in Spent Fuel Pools

In 1984, the NRC provided information supporting the low degradation rates of spent fuel in spent fuel pools based on national and international storage experience, which at that time totaled 18 years of experience with zirconium-clad fuel³ and 12 years of experience with stainless-steel-clad fuel (49 FR 34658). Examples of the cited information are:

² Appendix I provides additional information on the characteristics, storage, and transportation of high-burnup uranium oxide (UOX) spent fuel and mixed uranium-plutonium oxide (MOX) spent fuel.

³ In 1984, only two commercial light water reactor nuclear power plants used stainless-steel-clad fuel, whereas most used zirconium-clad fuel (49 FR 34658).

1. In *Behavior of Spent Nuclear Fuel in Water Pool Storage*, Johnson (1977) reported on corrosion studies of irradiated fuel at 20 reactor pools in the United States, finding no detectable degradation of zirconium cladding.
2. At the American Nuclear Society's Executive Conference on Spent Fuel Policy and its Implications, presented in Buford, Georgia, April 2 to 5, 1978, Johnson (1978) presented "Utility Spent Fuel Storage Experience," which reported that no degradation has been observed in commercial power reactor fuel stored in onsite pools in the United States and that extrapolation of corrosion data suggests that less than a tenth of a percent of the thickness of the zirconium clad would be corroded after 100 years.
3. In *The Long-Term Storage of Irradiated CANDU Fuel Under Water*, Walker (1979) concluded that "50 to 100 years under water should not significantly affect their [spent fuel bundles] integrity."

Almost 30 years of additional experience has been gained since the completion of the first Waste Confidence proceeding in 1984, during which time the technical basis for very slow degradation rates of spent fuel in spent fuel pools has continued to grow and now includes the wet storage of high-burnup fuel. Examples of this additional experience include the following:

1. In *Durability of Spent Nuclear Fuels and Facility Components in Wet Storage*, the IAEA (1998) summarized the durability of materials in wet storage, stating: "The zirconium alloys represent a class of materials that is highly resistant to degradation in wet storage, including some experience in aggressive waters. The only adverse experience involves Zircaloy clad metallic uranium where mechanical damage to the cladding was a prominent factor during reactor discharge, exposing the uranium metal fuel to aqueous corrosion. Otherwise, the database for the zirconium alloys supports a judgment of satisfactory wet storage in the time frame of 50 to 100 years or more."
2. In *Spent Fuel Performance Assessment and Research: Final Report of a Co-Ordinated Research Project on Spent Fuel Performance Assessment and Research (SPAR) 1997–2001*, the IAEA (2003b), while discussing spent fuel storage experience, reported on a detailed review of the degradation mechanisms of spent fuel cladding under wet storage and stated that "wet storage of spent fuel only appears to be limited by adverse pool chemistry or the deterioration of the fuel storage pool structure."
3. In *Understanding and Managing Ageing of Materials in Spent Fuel Storage Facilities*, the IAEA reported that "over more than 40 years of experience with several million LWR [light water reactor] rods, power reactor fuel with zirconium alloy cladding has had an excellent durability in wet storage" (IAEA 2006). The IAEA went on to state that "destructive and non-destructive examinations of fuel rods, visual evidence and coupon studies [IAEA 2006; pp. 11, 13, 54–58] all support resistance to aqueous corrosion. There have been no reports of fission gas evolution, indicative of cladding failure in wet storage. Rod consolidation campaigns have been conducted without any indication of storage-induced degradation."

Appendix B

There is a sufficient database to indicate that wet storage of fuel with zirconium alloy cladding can be extended for at least several decades.”

4. In *Impact of High Burnup Uranium Oxide and Mixed Uranium-Plutonium Oxide Water Reactor Fuel on Spent Fuel Management*, No. NF-T-3.8, (IAEA 2011a) the IAEA stated that because wet storage is associated with low temperatures, the clad material property degradation is expected to be low. However, the IAEA also recognized that high-burnup uranium oxide and MOX spent fuel storage in pools will increase the heat load and potentially cause radioactive releases, which may require an upgrade of the pool facility with respect to heat removal, pool cleanup systems, and additional neutron poison material in the pool water or in storage racks. In addition, the IAEA suggested that reevaluation of criticality and regulatory aspects may also be required for high-burnup fuel.

Based on available information and operational experience, degradation of the fuel cladding occurs very slowly over time in the spent fuel pool environment. Degradation of the spent fuel should be minimal over the short-term storage timeframe. The NRC expects that only routine maintenance will be needed over the short-term storage timeframe. However, it is possible that future evaluations and experience with high-burnup fuel could identify upgrades and enhancements to pool storage that would need to be implemented in the future (see discussion on regulatory framework in Section B.3.3). Although the NRC assumes in the GEIS that the spent fuel pool will be decommissioned before the end of the short-term storage timeframe, it is not aware of any information that would call into question the technical feasibility of continued safe storage of spent fuel in spent fuel pools beyond the short-term storage timeframe.

B.3.1.2 Robust Structural Design of Spent Fuel Pools

As described in Section 2.1.2.1 of the GEIS, spent fuel pools are massive, seismically designed structures that are constructed from thick, reinforced concrete walls and slabs that vary between 0.7 and 3 m (2 and 10 ft) thick. All spent fuel pools currently in operation are lined with stainless-steel liners that vary in thickness from 6 to 13 mm (0.25 to 0.5 in.).⁴ NUREG-1738 (NRC 2001), *Technical Study of Spent Fuel Pool Accident Risk at Decommissioning Nuclear Power Plants* indicates that spent fuel pool structures are designed to be seismically robust (i.e., it is expected that a seismic event with peak spectral acceleration significantly larger than that of the safe shutdown earthquake would be required to produce catastrophic failure of the structure) (NRC 2001). Further, in evaluating the seismic risk to spent fuel pools, NRC (2001) stated that “[i]n boiling-water reactor (BWR) plants, the pool structures are located in the reactor building at an elevation several stories above the ground. In pressurized-water reactor (PWR)

⁴ Dresden Unit 1 and Indian Point Unit 1 have no liner plates, but neither pool is currently operating. Both plants were permanently shut down more than 20 years ago and no safety-significant degradation of their concrete pool structures has been reported. At present, no spent fuel remains in either reactor’s spent fuel pool.

plants, the [spent fuel pool] structures are outside the containment structure and supported on the ground or partially embedded in the ground. The location and supporting arrangement of the pool structures affect their capacity to withstand seismic ground motion beyond their design basis. The dimensions of the pool structure are generally derived from radiation shielding considerations rather than seismic demand needs. Spent fuel structures at nuclear power plants are able to withstand loads substantially beyond those for which they were designed.” In *Spent Fuel Storage Operation—Lessons Learned* (IAEA 2013), the IAEA reported that pool storage is a mature technology and the latest storage pools have come through an evolutionary process and incorporate the learning from 50+ years of operating experience.

In the initial Waste Confidence proceeding, the Commission found that the risks of major accidents at spent fuel pools resulting in offsite consequences were remote because of the secure and stable character of the spent fuel in the spent fuel pool environment and the absence of reactive phenomena that might result in dispersal of radioactive material. The Commission noted that storage pools and independent spent fuel storage installations (ISFSIs) are designed to safely withstand accidents caused by either natural or man-made phenomena (49 FR 34658). By 1990, the NRC had spent several years studying the potential for a catastrophic loss of reactor spent fuel pool water, which could cause a spent fuel fire in a dry pool. The NRC concluded that, because of the large inherent safety margins in the design and construction of a spent fuel pool, no action was needed to further reduce the risk (55 FR 38472).

On March 11, 2011, an earthquake and subsequent tsunami resulted in significant damage to the nuclear facilities at Fukushima Dai-ichi. Subsequent analysis and inspections performed by Tokyo Electric Power Company personnel determined that the spent fuel pool water levels did not drop below the top of fuel in any spent fuel pool and that no significant fuel damage occurred (INPO 2011). Appendix F contains further discussion of the Fukushima event with respect to spent fuel pools.

The NRC has continued its examination of spent fuel pool storage to ensure that adequate safety is maintained and that there are no adverse environmental effects from the storage of spent fuel in spent fuel pools. The Office of Nuclear Reactor Regulation and the former Office for Analysis and Evaluation of Operational Data independently evaluated the safety of spent fuel pool storage, and the results of these evaluations were documented in a pair of memoranda to the Commission: *Resolution of Spent Fuel Storage Pool Action Plan Issues* (NRC 1996a) and *Assessment of Spent Fuel Pool Cooling* (NRC 1996b) (later published as NUREG-1275, Vol. 12, “*Operating Experience Feedback Report: Assessment of Spent Fuel Cooling*” [NRC 1997a]). As a result of these studies, the NRC and industry identified a number of follow-up activities, which are described by the NRC in a memorandum to the Commission *Follow-up Activities on the Spent Fuel Pool Action Plan* (NRC 1997b). These evaluations subsequently became part of the investigation of Generic Safety Issue 173, *Spent Fuel Pool*

Appendix B

Cooling for Operating Plants, which found that the relative risk posed by loss of spent fuel cooling is low compared with the risk of events not involving the spent fuel pool (NRC 2000).

The safety and environmental effects of spent fuel pool storage were also addressed in conjunction with regulatory assessments of permanently shutdown nuclear plants and decommissioning nuclear power plants. NUREG/CR-6451, *A Safety and Regulatory Assessment of Generic BWR and PWR Permanently Shutdown Nuclear Power Plants* (Travis et al. 1997), addressed the appropriateness of regulations (e.g., requirements for emergency planning and insurance) associated with spent fuel pool storage. The study also provided reasonable bounding estimates for offsite consequences for the most severe accidents, which would involve draining of the spent fuel pool (e.g., complete draining of the spent fuel pool occurs 12 days after shutdown of the reactor).

In 2001, the NRC issued NUREG-1738 (NRC 2001), *Technical Study of Spent Fuel Pool Accident Risk at Decommissioning Nuclear Power Plants*, which found that a postulated accident causing zirconium cladding fires could result in unacceptable offsite doses. Appendix F of this GEIS presents some results from NUREG-1738, including the largest number of early fatalities calculated (191). The large number of calculated fatalities was due, in part, to conservative assumptions for the ruthenium release (i.e., the release fraction is for a volatile fission product in an oxidic [rather than metallic] form), time of the accident (i.e., 30 days after shutdown of the reactor), and late evacuation of the public (i.e., evacuation is started after the release). More realistic assumptions (e.g., low ruthenium release, event occurs one year after shutdown), reduce the largest number of early fatalities from 191 to approximately two (NRC 2001). Although early fatalities are unacceptable, the annual likelihood for such an accident was estimated to be less than three chances in one million (NRC 2001). NUREG-1738 further states that “the risk at decommissioning plants is low and well within the Commission's safety goals. The risk is low because of the very low likelihood of a zirconium fire even though the consequences from a zirconium fire could be serious.” In arriving at this conclusion, NUREG-1738 considered a wide range of initiating events, including but not limited to, events that might lead to rapid loss of pool water (e.g., seismic events, cask drop, aircraft impact, and missiles generated by tornados). The low probability for these varied events to initiate a rapid loss of water from the pool is a direct result of the robustness of the structural design of the spent fuel pool.

As noted, spent fuel pools are massive structures constructed from thick, reinforced concrete walls and slabs designed to be seismically robust. Thus, the likelihood of major accidents at spent fuel pools resulting in offsite consequences is very remote. In particular, Appendix F determines that the environmental impacts from spent fuel pool fires are SMALL during the short-term storage timeframe based on the low risk of a spent fuel pool fire. The NRC is not aware of any additional studies that would cause it to question the low risk of spent fuel pool

accidents and thereby question the technical feasibility of continued safe storage of spent fuel in spent fuel pools for the short-term timeframe considered in the GEIS.

B.3.2 Technical Feasibility of Dry Cask Storage

The technical feasibility of dry cask storage is supported by years of experience and technical studies and NRC reviews that examined and confirmed the integrity of spent fuel and cladding under the controlled and benign environment within dry cask storage systems. The technical feasibility of these systems is further supported by the robustness of the structural design of the dry cask storage system against a variety of natural and human-induced challenges.

B.3.2.1 Low Degradation Rates of Spent Fuel in Dry Cask Storage

In the United States, spent fuel has been safely stored in dry casks for more than 25 years. In 1986, Virginia Power received a license for an at-reactor dry storage facility located at Surry Nuclear Power Plant. As of June 2014, there are operational ISFSIs at 64 sites in the United States. One operational ISFSI, at the GEH-Morris site, is a wet facility. The remaining ISFSIs are storing spent fuel in over 1,900 loaded dry casks. (see Section 2.1.2 in the GEIS for further details). As with wet storage, the overall experience with dry cask storage of similar fuel types, including the cladding, has been similar—slow degradation. In addition, spent fuel is cooled for a lengthy period in a spent fuel pool before being transferred into dry cask storage. NRC guidance regarding dry cask storage recommends a maximum cladding temperature of 400°C (752°F) and a dry, inert atmosphere to reduce the potential for significant degradation (NRC 2010c). Recent studies, including the following, have confirmed dry cask storage reliability:

1. A dry cask storage characterization project (Bare et al. 2001) examined and tested a dry cask storage system, the CASTOR V/21, and found “there was no evidence of cask, shielding, or fuel rod degradation during long-term (14 years) storage that would affect cask performance or fuel integrity.” The project examined zirconium-clad fuel applicable for spent fuel with a burnup of 35 GWd/MTU. A subsequent study (Einziger et al. 2003), which examined spent fuel from the Bare et al. (2001) project, suggests that the spent fuel cladding could remain a viable barrier to fission product release during extended storage up to 100 years in a dry cask environment.
2. The IAEA status report *Understanding and Managing Ageing of Materials in Spent fuel Storage Facilities* (IAEA 2006) stated “[P]ower reactor fuel with zirconium alloy cladding has been placed into dry storage in approximately a dozen countries. The technical basis for satisfactory dry storage of fuel clad with zirconium alloys includes hot cell tests on single rods, whole assembly tests, demonstrations using casks loaded with irradiated fuel assemblies and theoretical analysis.”

Appendix B

3. The Electric Power Research Institute (EPRI 1998) evaluated the data needs for long-term storage and reported that during normal storage of low-burnup spent fuel, “the lower radiation fields and estimated temperatures of 100–125°C after 20 years favor acceptable fuel behavior for extended storage.”

The NRC is aware that high-burnup and MOX fuel may be subject to increased degradation of the spent fuel and cladding that could cause further problems with handling, storing, and transporting spent fuel. With this increased usage, research has continued to improve understanding of degradation mechanisms affecting storage of spent fuel. Recent reports (e.g., NRC 2014; Hanson et al. 2012; IAEA 2011a; and Sindelar et al. 2011) have identified a variety of degradation mechanisms and discussed their potential effects on storage. For example, the mechanical integrity of the spent fuel cladding and assembly is important to ensure that handling and transportation of spent fuel can be conducted with relative ease. The mechanical designs of lower-burnup UOX and higher-burnup UOX or MOX fuel are very similar, but some of the after-irradiation properties of higher-burnup UOX and MOX are potentially significant in determining the rate of degradation or differences in performance. Differences in after-irradiation properties between lower-burnup UOX and higher-burnup UOX and MOX include higher fuel rod internal pressures and thinner cladding due to more cladding oxidation and hydride layer buildup causing higher cladding stress, higher decay heat, higher specific activity, and finer grain structure of the fuel pellet, potentially increasing the likelihood and consequences of an accident. Appendix I provides further discussion on the characteristics, storage, and transportation of high-burnup UOX and MOX spent fuel.

Although NRC regulations for dry cask storage allow for a licensing period of up to 40 years for both initial and renewed licenses, licensing periods approved for storage casks for high-burnup fuel have been limited to 20 years due to the more limited data available for high-burnup fuel. These storage times are sufficiently short and the degradation rates of spent fuel sufficiently slow that (1) significant storage, handling, and transportation issues are not expected to arise during a single license period and (2) should information collected during a license period identify any emerging issues and concerns, there would be sufficient time to develop regulatory solutions and incorporate them into future licensing periods.

Ongoing research into the extended storage of spent fuel is part of the NRC’s effort to continuously evaluate and update its safety regulations. As part of this effort, the NRC is examining the technical needs and potential changes to the regulatory framework that may be needed to continue licensing of spent fuel storage facilities over periods beyond 120 years. In 2014, the NRC published *Identification and Prioritization of the Technical Information Needs Affecting Potential Regulation of Extended Storage and Transportation of Spent Nuclear Fuel* (NRC 2014). This report considered high-burnup UOX fuel and MOX fuel. Further, international efforts are evaluating degradation mechanisms affecting handling, storage, and transportation of spent fuel (e.g., IAEA 2011a). The NRC, the DOE, other regulators, and the commercial power

industry have formed the Extended Storage Collaboration Program. The goal of this program is to better understand the degradation processes that could impact the storage of spent fuel. As new information becomes available, it will be considered in the development of canister design criteria and aging management requirements for the safe storage of spent fuel. Currently, EPRI is leading a multi-year research project, the majority of which is funded by DOE, to evaluate the safe storage of spent fuel in dry storage casks. EPRI will design and demonstrate dry cask technology at full scale for evaluating the condition of “high-burnup” spent fuel during storage. As research continues, if the NRC were to identify a concern with the safe storage of spent fuel, the NRC would evaluate the issue and take whatever action or make whatever change in its regulatory program necessary to protect public health and safety.

Based on available information and operational experience, degradation of the spent fuel should be minimal over the short-term storage timeframe if conditions inside the canister are appropriately maintained (i.e., consistent with the technical specifications for storage). Thus, the NRC expects that only routine maintenance will be needed over the short-term storage timeframe. Repackaging of spent fuel may be needed if storage continues beyond the short-term storage timeframe. In the GEIS, the NRC assumes that the dry casks would need to be replaced if storage continues beyond the short-term storage timeframe. Accidents associated with repackaging spent fuel are evaluated in Section 4.18 and the environmental impacts are SMALL because the accident consequences would not exceed the NRC accident dose standard contained in 10 CFR 72.106.

Spent fuel transfer operations can present challenges to operators and, in part, because of these challenges, transfer operations are conducted in enclosed, heavily shielded buildings with filters to reduce any potential releases. Although transfer operations at a current reactor would be conducted in the spent fuel pool and the dry transfer system would involve dry transfer, spent fuel transfer operations in either facility would occur within an enclosed, shielded building. Therefore, releases to the environment from handling operations within the spent fuel pool and the dry transfer system are expected to be similar. These operations routinely maintain public and occupational doses well within existing requirements. This is done despite variations in the facilities and equipment and the characteristics of the spent fuel being transferred. While these characteristics may vary, the safety regulations do not. In addition, the NRC requires that facilities and equipment be maintained to ensure safety functions are not compromised. Further, the NRC inspects operating facilities to verify compliance with requirements. As described in Section B.3.3.3 of this appendix, after the end of the reactor’s licensed life for operation, the licensee would continue to store spent fuel onsite under either its 10 CFR Part 72 general license granted to 10 CFR Part 50 or Part 52 reactor licensees or a specific 10 CFR Part 72 license. During this time, the licensee would remain under the NRC’s regulatory control and NRC inspections and oversight of storage facilities would continue. The NRC monitors the performance of ISFSIs (at decommissioned and shutdown reactor sites and at operating reactor sites) by conducting periodic inspections.

Appendix B

The opportunity to inspect spent fuel that has been placed into dry cask storage would occur during repackaging of the fuel. During the short-term timeframe, repackaging would occur, if needed, in the spent fuel pool, which would provide shielding and allow licensees to safely repackage the fuel. In the long-term and indefinite timeframes, repackaging would occur in the dry transfer system, which would be a shielded building. The NRC assumes replacement of dry casks after 100 years of service life; however, replacement times will depend on actual degradation observed during continued regulatory oversight for maintaining safety during continued storage. Studies and experience to date do not preclude a dry cask service life longer than 100 years. In addition, as described in Section 2.2.1.3 of the GEIS, in accordance with 10 CFR 72.42, ISFSI license renewal applications must include, among other things, (1) time-limited aging analyses that demonstrate that structures, systems, and components important to safety will continue to perform their intended safety function for the requested period of extended operation and (2) a description of the aging management program for management of issues associated with aging that could adversely affect structures, systems, and components important to safety. These requirements enhance confidence that spent fuel, including bare fuel, fuel in canisters, or damaged fuel that has been canned and stored in dry casks, could be retrieved for repackaging, if needed. Finally, regulatory experience shows that licensees have successfully dealt with damaged fuel. In the most extreme example, the damaged fuel from the core of Three Mile Island, Unit 2 (TMI-2), was removed and safely placed into storage. If this type of fuel can be successfully moved and managed, then it is reasonable to assume that damaged spent fuel in casks can be handled, if necessary. Although a commercial dry transfer system is currently not operating in the United States, construction and operation of a dry transfer system, including the handling of damaged fuel, can be accomplished with current technology (further information provided in Section 2.2.2.1 – Construction and Operation of a Dry Transfer System).

B.3.2.2 Robust Design of Dry Cask Storage Systems

Dry cask storage systems are passive systems (i.e., relying on natural air circulation for cooling) that are inherently robust, massive, and highly resistant to damage. To date, the NRC and licensee experience with ISFSIs and cask certification indicates that spent fuel can be safely and effectively stored using dry cask storage technology. There have not been any safety issues with dry cask storage.

In addition, the NRC's technical review supporting issuance of Materials License No. SNM-2513 for the Private Fuel Storage, LLC (PFS) facility has confirmed the technical feasibility of continuing storage at an away-from-reactor ISFSI under 10 CFR Part 72 (NRC 2006a). While issues extraneous to safety and protection of the environment have, to date,

prevented the licensee from going forward with the project,⁵ the NRC's extensive review of safety and environmental issues associated with construction and operation of the PFS facility provides further information supporting the technical feasibility of safe spent fuel storage at an away-from-reactor ISFSI for long periods following storage at a reactor site (i.e., in a spent fuel pool or at-reactor ISFSI).

The NRC has renewed three specific ISFSI licenses for an extended 40-year period. Because at that time Part 72 only provided for a renewal period of 20 years, an exemption was granted as part of the NRC's review of the safety of renewing Part 72 license for 40 years. The NRC published a final rule on February 16, 2011, to clarify the processes for the renewal of ISFSIs operated under the general license provisions of 10 CFR Part 72, for renewal of the Certificate of Compliance for dry cask storage systems, and for extending the license and renewal terms to 40 years (76 FR 8872). In these cases, the NRC's technical review has encompassed the applicant's evaluation of aging effects on the structures, systems, and components important to safety, supplemented by the applicant's aging management program. These comprehensive reviews support the technical feasibility of continued safe storage of spent fuel in these ISFSIs and thus reaffirm the technical feasibility of safe, interim dry storage for an extended period. While these license renewal cases address storage at an ISFSI for a period of up to 80 years (i.e., up to 40-year initial license, plus 40-year renewal), studies performed to date (e.g., Einziger et al. 2003; EPRI 2002; 55 FR 38472) have not identified any issues that would call into question the technical feasibility of long-term use of dry storage for low-burnup spent fuel.

In 2007, the NRC published a pilot probabilistic risk assessment methodology (NRC 2007) that identified the dominant contributors to risk associated with a welded-canister dry-spent-fuel-storage system at a specific boiling water reactor site. The NRC study developed and assessed a comprehensive list of initiating events, including dropping the cask during handling and external events during onsite storage (e.g., earthquakes, floods, high winds, lightning strikes, accidental aircraft crashes, and pipeline explosions) and reported that the analysis indicates that the overall risk of dry cask storage was found to be extremely low. (The NRC determined that the estimated aggregate risk is an individual probability of a latent cancer fatality of 1.8×10^{-12} during the period encompassing the initial cask loading and first year of service and 3.2×10^{-14} per year during subsequent years of storage [NRC 2007]).

Several characteristics of dry cask storage contribute to the low risk determined by the NRC study. First, these systems are passive. Second, they rely on natural air circulation for cooling.

⁵ Although a license was issued, the PFSF has not yet been constructed. However, the NRC determined, based on its review of the application, that there is reasonable assurance that if the PFSF is constructed (1) the activities authorized by the license can be conducted without endangering the health and safety of the public and (2) these activities will be conducted in compliance with the applicable regulations of 10 CFR Part 72 (NRC 2006a).

Appendix B

Third, their inherently robust, massive concrete and steel structure is highly resistant to damage. The robustness of these dry cask storage systems has been tested by significant challenges (e.g., the August 23, 2011 Mineral, Virginia earthquake that affected the North Anna Nuclear power plant and the March 11, 2011 earthquake and subsequent tsunami that damaged the Fukushima Dai-ichi nuclear power plant). Neither event resulted in significant damage to the dry cask storage containers or the release of radionuclides (VEPCO 2011; INPO 2011).⁷

Thus, technical studies and practical operating experience to date confirm the physical integrity of dry cask storage structures and thereby demonstrate the technical feasibility of continued safe storage of spent fuel in dry cask storage systems for the time periods considered in the GEIS. Further, the NRC expects that only routine maintenance will be needed over the short-term storage timeframe. Repackaging of spent fuel may be needed if storage continues beyond the short-term storage timeframe. The NRC is not aware of any issue that would cause it to question the technical feasibility of continued safe storage of spent fuel in dry casks for the timeframes considered in the GEIS. Further, the NRC continues to evaluate aging management programs and to monitor dry cask storage so that it can update its service life assumptions as necessary and consider any circumstances that might require repackaging of spent fuel earlier than anticipated.

B.3.3 Regulatory Oversight of Wet and Dry Spent Fuel Storage

A strong regulatory framework that includes both regulatory oversight and licensee compliance is important to the continued safe storage of spent fuel. As part of its oversight, the NRC can issue orders and new or amended regulations to address emerging issues that could impact the safe storage of spent fuel. This section provides a discussion of how the NRC's regulatory program has addressed potential safety and security concerns and routine operations. The environmental impact analysis in the GEIS relies upon the current regulatory framework, which includes whatever license amendments, orders, and rulemaking becomes necessary to protect public health and safety. These ongoing improvements to the NRC's regulatory structure are reflected in the NRC's upgrade of safety, environmental, and security requirements following historic events, (e.g., the regulatory changes following the TMI-2 accident in 1979; safety and security upgrades following the September 11, 2001 terrorist attacks; and the Task Force recommendations and improvements to safety following the March 11, 2011 earthquake and subsequent tsunami that crippled the Fukushima Dai-ichi nuclear power plant). These regulatory changes demonstrate the NRC's capability for prompt and vigorous response to new developments that warrant increased regulatory attention. Thus, the vitality and evolution of the NRC's regulatory requirements support a reasonable conclusion that continued storage, even

⁷ Dry casks at the Fukushima Dai-ichi nuclear power plant are stored in a shared dry cask storage building.

over extended periods of time beyond those regarded as most likely, will continue to be safe with the same or fewer environmental impacts.

B.3.3.1 Regulatory Actions for Routine Operations, Accidents, and Terrorist Activity

As part of its oversight, the NRC can issue orders and new or amended regulations to address emerging issues that could impact the safe storage of spent fuel. An example of the NRC's regulatory oversight is the NRC's actions following the TMI-2 accident in 1979. First, the NRC created a Bulletin and Orders Task Force to assure the immediate safety of all other operating power reactors. Next, the NRC established the TMI-2 Lessons Learned Task Force to identify and evaluate safety concerns requiring prompt licensing actions for operating reactors, beyond the immediate actions announced by the earlier Task Force. A set of short-term recommendations was published as NUREG-0578 in July 1979 (NRC 1979). The NRC then assessed recommendations that "would provide a comprehensive and integrated plan for all actions necessary to correct or improve the regulation and operation of nuclear facilities." This "TMI-2 Action Plan" was published as NUREG-0660 in May 1980 (NRC 1980a). These action items led NRC to issue a list of "Requirements for New Operating Licenses," published in NUREG-0694 (NRC 1980b), which was later clarified and superseded by NUREG-0737 (NRC 1980c). Finally, after issuance of TMI-2 Action Plan requirements, the NRC codified new reactor requirements by regulation (46 FR 26491).

Another example, following the terrorist attacks of September 11, 2001, the NRC undertook an extensive reexamination of spent fuel safety and security issues. In 2002, the NRC issued orders to licensees that required power reactors in decommissioning, spent fuel pools, and ISFSIs to enhance security and improve their capabilities to respond to, and mitigate the consequences of, a terrorist attack. For example, these orders required additional security measures, including increased patrols, augmented security forces and capabilities, and more restrictive site-access controls to reduce the likelihood of a successful terrorist attack. In 2007, the NRC issued a final rule revising the Design Basis Threat,⁸ which also increased the security requirements for power reactors and their spent fuel pools (72 FR 12705). More recently, in 2009, the NRC issued a final rule to further improve security measures at nuclear power reactors, including at spent fuel pools (74 FR 13926). This rule included improvements to security measures, such as enhancements to cyber security plans, facilitation of consistent application of preparatory actions with respect to air attacks, integration of the access authorization and security program requirements, and additional requirements for unarmed security personnel to ensure these personnel meet the minimum physical requirements commensurate with their duties.

⁸ A design basis threat provides a general description of the attributes of potential adversaries who might attempt to commit radiological sabotage or theft or diversion against which licensee's physical protection systems must defend with high assurance.

Appendix B

Section 4.19 of the GEIS describes the environmental impacts of potential acts of sabotage or terrorism involving the continued storage of spent fuel. This section acknowledges that as the immediate hazard posed by the high radiation levels of spent fuel diminishes over time, depending on burnup, so does the deterrent to handling by unauthorized persons. The NRC will consider this type of information in evaluating whether additional security requirements are warranted in the future.

The most recent examples of the NRC's response to unexpected developments are the additional requirements that the NRC has already imposed or is considering in response to the March 11, 2011 earthquake and subsequent tsunami that resulted in extensive damage to the six-unit Fukushima Dai-ichi nuclear power plant in Japan. On March 12, 2012, the NRC issued multiple orders and a request for information to all of its nuclear power plant licensees (NRC 2012a). The request for information was issued to all licensees to determine whether nuclear plant licenses should be modified, suspended, or revoked. The purpose of the request for information was to re-evaluate seismic and flooding hazards at operating reactor sites and to determine whether appropriate staffing and communication can be relied upon to coordinate event response during a prolonged station blackout event, as was experienced at Fukushima Dai-ichi. Section 4.18 and Appendix F provide further details regarding the NRC's orders and requests for information in response to the Fukushima event.

Another aspect of the NRC's regulatory program for continued storage at reactors and other licensed facilities involves generic communications. Generic communications include, but are not limited to, generic letters, bulletins, information notices, safeguards advisories, and regulatory issue summaries. Generic letters request licensee actions or information to address issues regarding emergent or routine matters of safety, security, safeguards, or environmental significance. Bulletins request licensee actions or information to address significant issues regarding matters of safety, security, safeguards, or environmental significance that have great urgency. Information notices are used to communicate operating or analytical experience to the nuclear industry. The industry is expected to review the information for applicability and consider appropriate actions to avoid similar problems. Regulatory issue summaries are used to communicate and clarify the NRC's technical or policy positions on regulatory matters.

For example, Information Notice 2012-20 (NRC 2012b) informed licensees about the potential for chloride-induced stress corrosion cracking of austenitic stainless steel and maintenance of dry cask storage system canisters. Although an immediate safety concern did not exist, the NRC alerted its licensees and certificate holders that their monitoring programs need to address this concern as part of an aging management program so that appropriate actions (e.g., maintenance) would be taken before there were any impacts.

Another example is Information Notice 2009-26, *Degradation of Neutron-Absorbing Materials in the Spent Fuel Pool*, with respect to criticality safety for pool storage (NRC 2009a). NRC licensees use various methods to meet subcriticality requirements in the spent fuel pool

specified by 10 CFR 50.68 or 10 CFR Part 50 Appendix A, General Design Criterion 62. Most spent fuel pools now store spent fuel assemblies in high-density racks, which incorporate neutron absorber materials into the rack walls. These neutron absorber materials, especially boraflex, can degrade enough to lose their neutron-absorbing capabilities and challenge subcriticality requirements (requirements to prevent an uncontrolled chain reaction). Due to this degradation, many licensees now employ other means to meet subcriticality requirements (e.g., spent fuel loading patterns, fuel burnup credit, control rods or other neutron poisons contained within spent fuel bundles, soluble boron in the pool water, or some combination of these methods). The NRC issued Information Notice 2009-26 to all operating reactors licensees and construction permit holders in October 2009 (NRC 2009a). The NRC continues to monitor how licensees are addressing the degradation issue. Most recently, on March 11, 2014, the NRC issued a draft generic letter for public comment that, if finalized, would request information from licensees to allow the NRC to “determine if the degradation of the neutron-absorbing materials in the SFP is being managed to maintain reasonable assurance that the materials are capable of performing their intended safety function, and if the licensees are in compliance with the regulations” (79 FR 13685).

B.3.3.2 Regulatory Oversight of Spent Fuel Pool Leaks

Spent fuel pool design and operational control requirements in NRC regulations make it unlikely that a leak will remain undetected long enough to result in public health and safety or environmental concerns. Long-standing design requirements include but are not limited to general design criteria in 10 CFR Part 50, Appendix A that focus on fuel storage and handling and radioactivity control (e.g., General Design Criterion 61). Operational controls include requirements for control of effluents and release of radioactive materials such as dose limits found in 10 CFR 20.1301 and design objectives found in 10 CFR Part 50, Appendix I.

There are also requirements that are new or have been updated in response to recent operational experience and related studies by NRC task forces. For example, a 2006 report by NRC’s Liquid Radioactive Release Lessons Learned Task Force made 26 specific recommendations for improvements to NRC regulatory programs (NRC 2006b). In 2010, the NRC Groundwater Task Force reevaluated the recommendations of the 2006 Task Force (NRC 2010d). A review of the Groundwater Task Force recommendations by NRC senior management concluded that further action was warranted (NRC 2011d). These studies have influenced specific changes to NRC requirements and guidance. For example:

- In June 2008, the NRC issued Regulatory Guide 4.21, *Minimization of Contamination and Radioactive Waste Generation: Life-Cycle Planning* (NRC 2008). The purpose of this regulatory guide is to present guidance that will assist applicants covered by 10 CFR 20.1406, “Minimization of contamination,” in effectively implementing this licensing requirement.

Appendix B

- In June 2009, the NRC issued revision 2 to Regulatory Guide 4.1 (NRC 2009b) provides guidance to licensees for detecting, evaluating, and monitoring releases from operating facilities via unmonitored pathways; to ensure consistency with current industry standards and commercially available radiation detection methodology; to clarify when a licensee's radiological effluent and environmental monitoring programs should be expanded based on data or environmental conditions; and to ensure that leaks and spills are detected before radionuclides migrate offsite via an unmonitored pathway.
- In July 2011, the NRC promulgated its Decommissioning Planning Rule, which added 10 CFR 20.1406(c) and modified 10 CFR 20.1501(a) and (b) (76 FR 35512). This rule requires all licensees to establish operational practices to minimize site contamination and perform reasonable subsurface radiological surveys and sets forth new financial assurance requirements.
- In December 2012, the NRC published Regulatory Guide 4.22, *Decommissioning Planning During Operations*, which provides methods acceptable to the NRC to use in implementing portions of the Decommissioning Planning Rule (NRC 2012c).

Appendix E of the GEIS provides a detailed description and evaluation of the historical data on spent fuel pool leaks, discusses ongoing and future monitoring activities and corrective actions, and analyzes potential environmental impacts that may occur during the short-term timeframe during which spent fuel storage in pools will continue. Appendix E concludes that the potential environmental impacts from spent fuel pool leakage would be SMALL.

B.3.3.3 Dry Cask Storage

Consistent with the NRC's regulatory framework for continued safe spent fuel storage in dry casks, reactor and ISFSI licensees have acted prudently to safely manage their spent fuel. In the late 1970s and early 1980s, the need for alternative storage began to grow as spent fuel pools at many nuclear reactors began to reach their licensed capacity. License amendments to allow spent fuel pool re-racking, fuel-pin consolidation, and specific or general licenses for onsite dry cask storage have been successfully employed to increase onsite storage capacity. As discussed previously, there are currently operational ISFSIs at 64 sites. The NRC is successfully regulating seven fully decommissioned reactor sites that contain ISFSIs licensed under either the general or specific license provisions of 10 CFR Part 72.¹¹

After the end of a reactor's licensed life for operation, the licensee would continue to store spent fuel onsite under either the 10 CFR Part 72 general license granted to 10 CFR Part 50 and Part 52 reactor licensees or a specific 10 CFR Part 72 license. During this time, the licensee

¹¹ These reactor sites include Maine Yankee, Yankee Rowe, Connecticut Yankee (also known as Haddam Neck), Fort St. Vrain, Rancho Seco, Trojan, and Big Rock Point.

would remain under the NRC's regulatory control and NRC inspections and oversight of storage facilities would continue. The NRC monitors the performance of ISFSIs (at both decommissioned and shutdown reactor sites and operating reactor sites) by conducting periodic inspections. When conducting inspections at these ISFSIs, NRC inspectors follow the guidance in NRC Inspection Manual Chapter 2690, *Inspection Program for Dry Storage of Spent Reactor Fuel at Independent Spent Fuel Storage Installations and for 10 CFR Part 71 Transportation Packages* (NRC 2012d).

The current regulatory framework for storage of spent fuel allows for multiple license renewals, subject to aging management analysis and planning. In early 2011, the Commission published a final rule that amended 10 CFR Part 72 to increase the initial and renewal terms for specific ISFSI licenses from "not to exceed 20 years" to "not to exceed 40 years" (76 FR 8872). The Commission concluded that, with appropriate aging management and maintenance programs, license terms not to exceed 40 years are reasonable and adequately protect public health and safety. An applicant for a storage license renewal must provide appropriate technical bases for identifying and addressing aging-related effects and must develop specific aging management plans to justify extended operations of ISFSIs. The regulatory framework for storage is supported by well-developed regulatory guidance; voluntary domestic and international consensus standards; research and analytical studies; and processes for implementing licensing reviews, inspection programs, and enforcement oversight.

B.3.3.4 Summary of Information on Regulatory Oversight

The NRC will continue its regulatory control and oversight of spent fuel storage at both operating and decommissioned reactor sites under both specific and general 10 CFR Part 72 licenses. Decades of operating experience and ongoing NRC inspections demonstrate that these reactor and ISFSI licensees continue to meet their obligation to safely store spent fuel in accordance with the NRC's requirements. If the NRC were to find noncompliance with these requirements or otherwise identify a concern with the safe storage of the spent fuel, the NRC would evaluate the issue and take necessary action or change its regulatory program to protect the public health and safety and the environment.

As noted in the preceding paragraphs, licensees have continued to develop and successfully use onsite spent fuel storage capacity in the form of spent fuel pool and dry cask storage in a safe and environmentally sound fashion. Based on the preceding discussion, the NRC believes that for the storage timeframes considered in the GEIS, regulatory oversight will continue in a manner consistent with NRC's regulatory actions and oversight in place today to provide for continued safe storage of spent fuel as long as spent fuel needs to be stored.

B.3.4 Continued Institutional Controls

As discussed in the previous sections of this appendix, continued safe storage of spent fuel requires both the technical feasibility of safe storage and a regulatory framework that provides for monitoring and oversight to address the potential for evolving issues. To ensure adequate protection of public health and safety, the institutional controls provided by the NRC's regulatory structure and that of sister agencies, as well as by Federal, State and local governments in general, must be maintained over time. The GEIS takes the following approach to institutional controls:

1. the GEIS's evaluation of reasonably foreseeable environmental impacts of continued storage requires an assumption that institutional controls will be maintained;
2. the most reasonably foreseeable assumption is that institutional controls will continue;
3. accidents provide a helpful surrogate for analysis of a temporary lapse in institutional controls, including perspectives on the environmental implications of such a lapse; and
4. although too remote to calculate meaningfully, a permanent loss of institutional controls would likely have catastrophic consequences.

A detailed discussion for each of these topics is provided below.

1. An evaluation of reasonably foreseeable environmental impacts in the GEIS requires an assumption that institutional controls will be maintained

In *New York v. NRC*, the Court of Appeals held that because the NRC had not demonstrated that the unavailability of a repository was "remote and speculative," the National Environmental Policy Act (NEPA) required the NRC to analyze the environmental impacts of continued storage in the absence of a repository. The NRC believes that, if geologic disposal were not possible, national spent fuel policy would change but would not default to relying on the storage facilities as they currently exist—the design of facilities and the regulations governing those facilities would change to accommodate the new policy. Further, the NRC is not in a position to predict how the policy would change or what technical advancements would become available to serve a new national policy if geologic disposal were not feasible or achievable by consensus. Analyzing the consequences of failing to secure a repository requires assumptions about what indefinite continued storage would encompass. Because the current methods of continued storage employ institutional controls, the NRC considered whether it was reasonable to assume that institutional controls would remain in place in the timeframes being considered, and, as explained below, concluded that the assumption is reasonable for the purposes of this GEIS. While the NRC does not believe that the indefinite storage scenario described in the GEIS is likely, the NRC has analyzed this scenario in the GEIS to provide a conservative picture of the environmental impacts should a repository not become available by the end of the long-term timeframe.

As stated in Chapter 1 of this GEIS, the Federal government, by national policy set forth in the Nuclear Waste Policy Act, has assumed responsibility for the permanent disposal of high-level radioactive waste and spent fuel. The Nuclear Waste Policy Act specifies that the cost of both interim storage and permanent disposal is the responsibility of the generators and owners of the waste. Further, the Nuclear Waste Policy Act defines the current national strategy for disposition of spent fuel as disposal in a geologic repository; the geologic repository strategy was recently reaffirmed by the Blue Ribbon Commission on America's Nuclear Future (BRC 2012).

In response to the Blue Ribbon Commission's report (BRC 2012), the DOE expressed its intent to provide a repository by 2048 (DOE 2013), which is about 10 years before the end of the short-term timeframe for the oldest spent fuel storage facility within the scope of this analysis. In this GEIS, the NRC concludes that a repository is most likely to be available by the end of the short-term timeframe, and failing that, likely to be available by the end of the long-term timeframe. In the event a repository could not be sited by the end of the long-term timeframe, the NRC has concluded that it is not reasonable to assume that national policy would default to complete inaction so as to leave spent fuel in dry casks unprotected, much less unattended or ultimately forgotten. However, because an alternate path forward is unknown at this point, the NRC has not attempted to forecast a different solution and assumes that continued storage continues indefinitely.

Should the national policy change from geologic disposal to permanent storage (i.e., onsite or away-from-reactor "disposal" in facilities that resemble ISFSIs), the NRC expects that planning and decision-making for permanent storage of spent fuel would take into account the appropriate balance of engineering design and institutional controls to address the challenges presented by permanent storage. There is no national historic precedent and, more particularly, no regulatory history of nuclear materials to suggest that the Federal government, including the NRC in its assigned role under the Atomic Energy Act, would not engage in planning and decision-making regarding whatever further changes or enhancements would be necessary to accommodate permanent storage, in the unlikely event that option was adopted. Should national policy change to a policy of permanent storage, the NRC believes that significant regulatory changes and design modifications would be required to transfer spent fuel to offsite facilities or convert onsite continued storage facilities to onsite permanent storage facilities. Further, even if a repository does not become available, the NRC believes that, based on the factors discussed in the next section, institutional controls will be maintained as long as the spent fuel needs to be stored.

With respect to costs, the NRC acknowledges that, because of delays in the siting and licensing of a repository, the Federal government bears an increasing share of the financial responsibility for storage costs. Although the annual costs for continued storage are manageable, cumulative costs will continue to increase. The Federal government has estimated it will pay a total of approximately \$20 billion in damage awards and settlements by the year 2020 and \$500 million

per year after that if DOE does not accept fuel by 2021 and spent fuel continues to accumulate at reactor sites (GAO 2013). Thus, the escalating costs of continued storage provide incentive for the Federal government to implement the national policy for disposal of spent fuel in a deep geologic repository.

The assumption that institutional controls will continue enables an appropriate and reasonable evaluation of the environmental impacts of continued storage over an indefinite timeframe. Absent the stability and predictability that follows from institutional controls, including but not limited to NRC licensing and regulatory controls, few impacts could be reliably forecast. The “hard look” required by NEPA would quickly become unfocused, highly speculative, and ill-defined. Analyzing the impacts that might result from a permanent and total loss of institutional controls would require NRC to reach unsupportable conclusions about how and when our nation, and its government, institutions, and social cohesiveness might degrade or even collapse. Such speculation would preclude meaningful calculations of impacts for the timeframes envisioned in the GEIS.

2. The assumption that institutional controls continue is reasonable

Consistent with NEPA’s rule of reason, which provides that agencies conduct an analysis according to the usefulness of the information to the decision-maker and full disclosure to the public of predictable benefits and impacts, this GEIS assumes that institutional controls at any storage site are maintained. This assumption is reasonable for two reasons: First, in any timeframe it would be illogical for any government at any level to abandon the storage facilities, given the particular hazards of the fuel. Continued storage is designed to allow the eventual transport of the spent fuel to a repository, not to permanently sequester the material from the environment without continued active oversight and maintenance. Second, these highly visible storage facilities are much less likely than buried geologic repositories to simply be forgotten.

Spent fuel is highly hazardous, requiring robust containment structures to minimize exposure risks. Spent fuel in storage facilities on the surface of the earth presents a visible hazard that requires active oversight to ensure safety and security measures are maintained and functioning as designed. Storage facilities remain under license and have aging management programs to support their continued maintenance and monitoring. Thus, the visibility of storage facilities and the hazards of spent fuel strongly support the reasonableness of assuming the continuation of institutional controls throughout all of the timeframes analyzed in the GEIS. While changes may occur over time to governments or society, highly visible, hazardous facilities are unlikely to be left abandoned or forgotten. As a result, it is a reasonable assumption that any government would, in the interest of its citizenry, ensure that appropriate oversight (e.g., monitoring, maintenance, and replacement of facilities as needed) remains in place, consistent with radiation protection principles and regulatory restrictions, until final disposition of the spent fuel occurs. Accordingly, the NRC has determined that the assumption of continued institutional controls is reasonable in each of the timeframes considered in the GEIS.

In contrast, consideration of the loss of institutional controls in the context of disposal of spent fuel—as in DOE’s Yucca Mountain environmental impact statement (EIS), for example—is not directly applicable to storage: NRC regulations for deep geologic disposal of spent fuel recognize there is a point when the repository ceases operation, is permanently closed, and the license terminated. After permanent closure, regulations specify institutional controls (e.g., the requirements to place markers to identify what is buried deep below the surface of the earth and to maintain records regarding the hazard). However, these institutional controls are part of a defense-in-depth approach to disposal; the facility design is not permitted to rely on those institutional controls to meet postclosure safety requirements.

Additionally, as identified in the public comments for this proceeding (see Appendix D of the GEIS), a repository applicant is required to prepare a stylized calculation to evaluate the consequences should humans inadvertently disrupt the repository (see 10 CFR 63.322). These requirements for disposal address the situation where human activities could occur at a disposal site that is no longer recognizable at the earth’s surface following waste burial, permanent closure of the facility, and license termination. However, in contrast to underground disposal facilities, aboveground storage installations are not designed to be abandoned and will remain highly visible on the earth’s surface. As explained previously, the visibility and purpose of temporary storage facilities differ significantly from those of permanent disposal facilities, supporting the reasonableness of assuming that institutional controls over continued storage facilities will be maintained.

The NRC recognizes information presented by the National Academies National Research Council and others regarding the durability of institutional controls (e.g., NAS 1995, 2000). The NRC is also aware of international reports that discuss the durability of institutional controls (e.g., NEA 2006, IAEA 2011b). However, this commentary does not conclude that a permanent loss of institutional controls is likely or that effective government and governmental oversight of continued storage will cease in the distant future. Rather, these documents focus on developing plans and strategies regarding what should be done today to address future uncertainty due, in part, to institutional controls.

For example, the Board on Radioactive Waste Management, in its study on long-term institutional management, stated: “No plan developed today is likely to remain protective for the duration of the hazards. Instead, long-term institutional management requires periodic, comprehensive reevaluation of those legacy waste sites still presenting risk to the public and the environment to ensure that they do not fall into neglect and that advantage is taken of new opportunities for their further remediation” (NAS 2000). While regulations may need to be updated over time, the NRC does not view possible future regulatory updates as an impediment to a current understanding of likely environmental impacts of continued storage. Further, future regulatory development would be expected to be undertaken to enhance and improve the effectiveness of regulatory oversight.

3. Accident analysis provides a perspective on the environmental impacts of a temporary lapse of institutional controls

The GEIS considers the environmental impacts of accidents during continued storage (e.g., certain cask drop events) in Section 4.18. These accidents, for the purposes of this NEPA analysis may serve as a surrogate or proxy for the temporary loss of institutional controls, and the impacts of these accidents are representative of impacts from a temporary loss of institutional controls. An accident condition approximates a limited period during which institutional controls are less than effective, after which the NRC expects that institutional controls and oversight would resume. Consequences from accidents resulting in small releases represent a lapse in more routine maintenance tasks, whereas accidents resulting in significant radioactive releases constitute a reasonable surrogate to evaluate consequences that might result from hypothetical acts of radiological sabotage or terrorism in the indefinite timeframe. Consideration of accident consequences thereby provides a reasonable basis for understanding the consequences of continued storage should institutional controls prove temporarily ineffective.

Given the physical characteristics of spent fuel, in most cases, the level of institutional controls necessary for safety would diminish over time and the consequences associated with accidents made possible by lapses in institutional controls would be expected to decrease with the passage of time. The thermal output of spent fuel decreases by approximately a factor of ten in the first 100 years after it is removed from the reactor, which means that maintenance activities and related institutional controls could be adjusted, as appropriate, to account for lower thermal loads. Therefore, the consequences of ineffective institutional controls will diminish over time because lower thermal loads should reduce the need for maintenance activities to maintain safety and lower radioactivity should reduce the consequences of releases of spent fuel. In contrast, institutional controls with respect to security may not diminish. As discussed in Section 4.19.2 of the GEIS, because spent fuel radiation levels will decrease over time, spent fuel could become more susceptible to theft or diversion (i.e., a more attractive target to individuals with malevolent intent). For this reason, additional security requirements may be necessary in the future if spent fuel remains in storage, to ensure that risk posed due to theft or diversion remains very low.

4. Impacts of loss of institutional controls

Some comments recommended that the NRC consider the evaluation of the loss of institutional controls based, in part, on DOE's Yucca Mountain EIS (DOE 2008b), which included an analysis for the loss of institutional controls for storage facilities under the no-action alternative. The NRC notes that DOE's proposed action in that instance was the construction of a repository and that, as a result, analysis of the no-action alternative was required by NEPA. Permanent disposal of spent fuel is a DOE responsibility, and DOE's analysis was designed to evaluate the environmental impacts of not meeting that responsibility. DOE evaluated the storage of the total

volume of high-level waste (i.e., 70,000 MTU) that would be disposed at the repository and, as a means of evaluating what would happen if it took no action, it considered the consequences of a simultaneous loss of institutional controls at 72 commercial and 5 DOE storage sites. In contrast, this GEIS considers the environmental impacts of continued storage at a single generically profiled commercial facility. While the DOE analysis may have sufficed for DOE's Yucca Mountain EIS, the NRC does not believe that the passive scenario assumed as part of the no-action alternative there provides a meaningful method of analyzing the consequences of indefinite storage for purposes of analyzing continued storage in this GEIS.

DOE's analysis evaluates degradation of the storage structures in the absence of human intervention (i.e., that neither government nor local residents, or even malevolent forces, would respond to the degradation in any fashion over a 10,000-year period). DOE did not state that its analysis of the loss of institutional controls represents the reasonably foreseeable impacts of permanent aboveground storage. To the contrary, DOE stated that neither of the no-action scenarios is likely to occur (DOE 2002). However, DOE's Yucca Mountain EIS (DOE 2008b) concluded that the consequences of the potential loss of institutional controls could be "catastrophic" in some resource areas.

As discussed previously, merely assuming loss of institutional controls in the distant, but undefined, future is not enough for the NRC to reasonably foresee when and how the loss of institutional controls might occur, and the consequences of that loss, with the kind of detailed and scientifically supportable analysis of resource impacts that the GEIS provides in every other respect for decision-makers and the public. Rather, the NRC would need to hypothesize the extent to which controls must fail before spent fuel would be effectively abandoned. The difficulty in predicting future consequences is further compounded by the lack of any credible way to foresee the combination of human and natural forces that might act on abandoned storage casks and cause a release. In addition, the baseline human environment becomes increasingly unpredictable the further out in time projections are made.

Nevertheless, the NRC can state broadly that, if institutional controls should be lost through a gradual dissolution of government or an apocalyptic event, unmitigated physical deterioration of spent fuel casks and cladding over decades, if not centuries, would eventually expose radionuclides to the environment. While the consequences—as explained above—are unpredictable, the NRC can state qualitatively that the consequences of such a catastrophe to the environment and public health could be similar to the impacts DOE analyzed for the no-action alternative (scenario 2—permanent loss of institutional controls) in its Yucca Mountain EIS (assuming a similar number of facilities were considered). Thus, in the event of a permanent loss of institutional controls, the resulting consequences to the environment across nearly all resource areas would be clearly noticeable and destabilizing.

B.3.5 Summary of Technical Feasibility of Continued Storage

As discussed previously, the NRC believes that it is reasonable to assume that the storage of spent fuel in any combination of storage in spent fuel pools or dry casks will continue as a licensed activity under regulatory controls and oversight. Licensees have continued to develop and successfully use onsite spent fuel storage capacity in the form of spent fuel pool and dry cask storage in a safe and environmentally sound fashion. Technical understanding and operational experience continues to support the technical feasibility of safe storage of spent fuel in spent fuel pools and in dry casks over long periods of time (e.g., slow degradation of spent fuel during storage in spent fuel pools and dry casks; engineered features of storage pools and dry casks to safely withstand accidents caused by either natural or man-made phenomena). In addition, regulatory oversight has been shown to enhance safety designs and operations as concerns and information evolve over time (e.g., safety enhancements made after the Three Mile Island accident in 1979, the September 11, 2001 terrorist attacks, and the March 11, 2011 Fukushima Dai-ichi disaster).

Based on the technical information and the national and international experience with wet and dry storage of spent fuel, the NRC concludes it is technically feasible to safely store spent fuel in either wet or dry storage for the short-term storage timeframe with only routine maintenance (i.e., no large-scale replacement of spent fuel pools or dry cask storage systems).

In the GEIS, the NRC assumes that after the short-term storage timeframe, spent fuel is stored in dry casks. Further, as discussed previously, the NRC concludes that there is no technical reason that spent fuel cannot be safely stored in dry casks beyond the short-term storage timeframe. As discussed in this appendix, the degradation rates of spent fuel are low under dry storage conditions and the probability of accidents with large consequences are very low. Storage of spent fuel beyond the short-term storage timeframe would continue under an approved aging management program to ensure that monitoring and maintenance are adequately performed. Repackaging of spent fuel may be needed if storage continues beyond the short-term storage timeframe. In the GEIS, the NRC assumes the replacement of dry casks after 100 years of service life; however, actual replacement times will depend on actual degradation observed during continued regulatory oversight for maintaining safety during continued storage. Studies and experience to date do not preclude a dry cask service life longer than 100 years. Accidents associated with repackaging spent fuel are evaluated in Section 4.18 and the environmental impacts are SMALL because the accident consequences would not exceed the NRC accident dose standard contained in 10 CFR 72.106. The NRC concludes it is technically feasible to continue to store spent fuel beyond the short-term storage timeframe, which may include activities to repackage spent fuel.

Section 4.19 of the GEIS describes the environmental impacts of potential acts of sabotage or terrorism involving the continued storage of spent fuel. This section acknowledges that as the immediate hazard posed by the high radiation levels of spent fuel diminishes over time so does

the deterrent to handling by unauthorized persons. The Blue Ribbon Commission's report noted that "over long time periods (perhaps a century or more, depending on burnup and the level of radiation that is deemed to provide adequate self-protection), the fuel could become more susceptible to possible theft or diversion (although other safeguards would remain in place). This in turn could require changes to the security requirements for older spent fuel. Extending storage to timeframes of more than a century could thus require increasingly demanding and expensive security protections at storage sites." If necessary, the NRC will issue orders or enhance its regulatory requirements for ISFSI security, as appropriate, to provide adequate protection of public health and safety and the common defense and security.

B.4 Conclusions

This appendix evaluates the technical feasibility of continued storage and repository availability, including national and international experience with storage and disposal of spent fuel. Based on the information and experience presented in this appendix, the NRC concludes that (1) a geologic repository is technically feasible; (2) the time period needed to develop a repository is approximately 25 to 35 years; (3) continued safe storage of spent fuel in spent fuel pools for the short-term timeframe is technically feasible; and (4) continued safe storage of spent fuel in dry casks for the timeframes considered in the GEIS is technically feasible. Further, the NRC concludes that a strong regulatory framework including both regulatory oversight and licensee compliance is important to the continued safe storage of spent fuel. As discussed in this appendix, the regulatory framework for storage is supported by well-developed regulatory guidance; voluntary domestic and international consensus standards; research and analytical studies; and processes for implementing licensing reviews, inspection programs, and enforcement oversight.

References

10 CFR Part 20. *Code of Federal Regulations*, Title 10, *Energy*, Part 20, "Standards for Protection against Radiation." Washington, D.C.

10 CFR Part 50. *Code of Federal Regulations*, Title 10, *Energy*, Part 50, "Domestic Licensing of Production and Utilization Facilities." Washington, D.C.

10 CFR Part 51. *Code of Federal Regulations*, Title 10, *Energy*, Part 51, "Environmental Protection Regulations for Domestic Licensing and Related Regulatory Functions." Washington, D.C.

10 CFR Part 52. *Code of Federal Regulations*, Title 10, *Energy*, Part 52, "Licenses, Certifications, and Approvals for Nuclear Power Plants." Washington, D.C.

Appendix B

10 CFR Part 63. *Code of Federal Regulations*, Title 10, *Energy*, Part 63, “Disposal of High-Level Radioactive Wastes in a Geologic Repository at Yucca Mountain, Nevada.” Washington, D.C.

10 CFR Part 71. *Code of Federal Regulations*, Title 10, *Energy*, Part 71, “Packaging and Transportation of Radioactive Material.” Washington, D.C.

10 CFR Part 72. *Code of Federal Regulations*, Title 10, *Energy*, Part 72, “Licensing Requirements for the Independent Storage of Spent Nuclear Fuel, High-Level Radioactive Waste, and Reactor-Related Greater than Class C Waste.” Washington, D.C.

46 FR 26491. May 13, 1981. “Licensing Requirements for Pending Operating License Applications: Proposed Rule.” *Federal Register*, U.S. Nuclear Regulatory Commission, Washington, D.C.

49 FR 34658. August 31, 1984. “Waste Confidence Decision and Requirements for Licensee Actions Regarding the Disposition of Spent Fuel Upon Expiration of Reactor Operating Licenses; Final Rules.” *Federal Register*, U.S. Nuclear Regulatory Commission, Washington, D.C.

55 FR 38472. September 18, 1990. “Consideration of Environmental Impacts of Temporary Storage of Spent Fuel After Cessation of Reactor Operation; and Waste Confidence Decision Review; Final Rules.” *Federal Register*, U.S. Nuclear Regulatory Commission, Washington, D.C.

72 FR 12705. March 19, 2007. “Design Basis Threat.” *Federal Register*, U.S. Nuclear Regulatory Commission, Washington, D.C.

73 FR 53284. September 15, 2008. “Department of Energy; Notice of Acceptance for Docketing of a License Application for Authority To Construct a Geologic Repository at a Geologic Repository Operations Area at Yucca Mountain, NV.” *Federal Register*, U.S. Nuclear Regulatory Commission, Washington, D.C.

74 FR 13926. March 27, 2009. “Power Reactor Security Requirements; Supplemental Proposed Rule.” *Federal Register*, U.S. Nuclear Regulatory Commission, Washington, D.C. Accession No. ML080570264.

76 FR 8872. February 16, 2011. “License and Certificate of Compliance Terms.” *Federal Register*, U.S. Nuclear Regulatory Commission, Washington, D.C.

76 FR 35512. June 17, 2011. “Decommissioning Planning.” *Federal Register*, U.S. Nuclear Regulatory Commission, Washington, D.C.

79 FR 13685. March 11, 2014. "Monitoring of Neutron-Absorbing Materials in Spent Fuel Pools." *Federal Register*, U.S. Nuclear Regulatory Commission, Washington, D.C.

Ahn, J. and M.J. Apted, eds. 2010. *Geological Repository Systems for Safe Disposal of Spent Nuclear Fuels and Radioactive Wastes*. Woodhead Publishing Series in Energy, Number 9, Oxford, England.

Atomic Energy Act of 1954, as amended. 42 USC 2011 *et seq.*

Bare, W.C. and L.D. Torgerson. 2001. *Dry Cask Storage Characterization Project-Phase 1: CASTOR V/21 Cask Opening and Examination*. NUREG/CR-6745, Idaho National Engineering and Environmental Laboratory, Idaho Falls, Idaho. Accession No. ML013020363.

BRC (Blue Ribbon Commission on America's Nuclear Future). 2012. "Report to the Secretary of Energy." U.S. Department of Energy, Washington, D.C. Accession No. ML120970375.

CEAA (Canadian Environmental Assessment Agency). 1998. *Report of the Nuclear Fuel Waste Management and Disposal Concept Environmental Assessment Panel*. Canadian Nuclear Fuel Waste Disposal Concept Environmental Assessment Panel, Quebec, Canada. Available at <http://www.ceaa-acee.gc.ca/default.asp?lang=En&n=0B83BD43-1>.

DECC (United Kingdom Department of Energy and Climate Change). 2013. "Managing Radioactive Waste Safely: Implementing Geological Disposal Annual Report April 2012–March 2013." URN 13D/152, London, United Kingdom. Available at: https://www.gov.uk/government/uploads/system/uploads/attachment_data/file/210928/MRWS_3rd_Annual_Report.pdf.

DECC (United Kingdom Department of Energy and Climate Change). 2014. "Implementing Geological Disposal." URN 14D/235, London, United Kingdom. Available at https://www.gov.uk/government/uploads/system/uploads/attachment_data/file/332890/GDF_White_Paper_FINAL.pdf.

DOE (U.S. Department of Energy). 2002. *Final Environmental Impact Statement for a Geologic Repository for the Disposal of Spent Nuclear Fuel and High-Level Radioactive Waste at Yucca Mountain, Nye County, Nevada*. DOE EIS-0250F, Office of Civilian Radioactive Waste Management, Las Vegas, Nevada. Accession No. ML032690321.

DOE (U.S. Department of Energy). 2008a. *Yucca Mountain Repository License Application*. DOE/RW-0573, Revision 0, Washington, D.C. Accession No. ML081560400.

DOE (U.S. Department of Energy). 2008b. *Final Supplemental Environmental Impact Statement for a Geologic Repository for the Disposal of Spent Nuclear Fuel and High-Level*

Appendix B

Radioactive Waste at Yucca Mountain, Nye County, Nevada. DOE EIS–0250F–S1, Office of Civilian Radioactive Waste Management, Las Vegas, Nevada. Accession No. ML081750212.

DOE (U.S. Department of Energy). 2013. *Strategy for the Management and Disposal of Used Nuclear Fuel and High-Level Radioactive Waste.* Washington, D.C. Accession No. ML13011A138.

DOE (U.S. Department of Energy). 2014. *Accident Investigation Report, Phase I – Radiological Release Event at the Waste Isolation Pilot Plant on February 14, 2014.* Washington, D.C. Available at http://www.wipp.energy.gov/Special/AIB_Final_WIPP_Rad_Release_Phase1_04_22_2014.pdf.

Einziger, R.E., H. Tsai, M.C. Billone, and B.A. Hilton. 2003. *Examination of Spent PWR Fuel Rods after 15 Years in Dry Storage.* NUREG/CR–6831, Argonne National Laboratory, Argonne, Illinois. Accession No. ML032731021.

EPRI (Electric Power Research Institute). 1998. *Data Needs for Long-Term Dry Storage of LWR Fuel.* Report TR–108757, Palo Alto, California. Available at <http://www.epri.com/search/Pages/results.aspx?k=Data%20Needs%20for%20Long-Term%20Dry%20Storage%20of%20LWR%20Fuel>.

EPRI (Electric Power Research Institute). 2002. *Technical Bases for Extended Dry Storage of Spent Nuclear Fuel.* Report 1003416, Palo Alto, California. Available at <http://cybercemetery.unt.edu/archive/brc/20120621083703/http://brc.gov/sites/default/files/documents/1003416.pdf>.

GAO (U.S. Government Accountability Office). 2013. *Commercial Spent Fuel: Observations on the Key Attributes and Challenges of Storage and Disposal Options.* GAO–13-532T, Washington, D.C. Available at <http://www.gao.gov/products/GAO-13-532T>.

Hanson, B., H. Alsaed, C. Stockman, D. Enos, R. Meyer, and K. Sorenson. 2012. *Gap Analysis to Support Extended Storage of Used Nuclear Fuel Rev. 0.* U.S. Department of Energy Report No. FCRD-USED-2011-000136 Rev. 0, Richland, Washington. Available at <http://energy.gov/sites/prod/files/Gap%20Analysis%20Rev%200%20Final.pdf>.

IAEA (International Atomic Energy Agency). 1997. *Joint Convention on Safety of Spent Fuel Management and on Safety of Radioactive Waste Management.* INFCIRC/546, Vienna, Austria. Available at <http://www.iaea.org/Publications/Documents/Infcircs/1997/infcirc546.pdf>.

IAEA (International Atomic Energy Agency). 1998. *Durability of Spent Nuclear Fuels and Facility Components in Wet Storage.* IAEA–TECDOC–1012, Vienna, Austria. Available at http://www-pub.iaea.org/MTCD/publications/PDF/te_1012_prn.pdf.

IAEA (International Atomic Energy Agency). 2001. *The Use of Scientific and Technical Results from Underground Research Laboratory Investigations for the Geologic Disposal of Radioactive Waste*. IAEA–TECDOC–1243, Vienna, Austria. Available at http://www-pub.iaea.org/MTCD/Publications/PDF/te_1243_prn.pdf.

IAEA (International Atomic Energy Agency). 2003a. *Scientific and Technical Basis for the Geologic Disposal of Radioactive Wastes*. Technical Reports Series No. 413, Vienna, Austria. Available at http://www-pub.iaea.org/MTCD/publications/PDF/TRS413_web.pdf.

IAEA (International Atomic Energy Agency). 2003b. *Spent Fuel Performance Assessment and Research: Final Report of a Co-Ordinated Research Project on Spent Fuel Performance Assessment and Research (SPAR) 1997–2001*. IAEA–TECDOC–1343, Vienna, Austria. Available at http://www-pub.iaea.org/MTCD/Publications/PDF/TE_1343_web.pdf.

IAEA (International Atomic Energy Agency). 2005. *Radioactive Waste Management Studies and Trends*. IAEA/WMDB/ST/4, Vienna, Austria. Available at <http://www-pub.iaea.org/MTCD/publications/PDF/WMDB-ST-4.pdf>.

IAEA (International Atomic Energy Agency). 2006. *Understanding and Managing Ageing of Materials in Spent Fuel Storage Facilities*. Technical Reports Series No. 443, Vienna, Austria. Available at http://www-pub.iaea.org/MTCD/Publications/PDF/TRS443_web.pdf.

IAEA (International Atomic Energy Agency). 2011a. *Impact of High Burnup Uranium Oxide and Mixed Uranium-Plutonium Oxide Water Reactor Fuel on Spent Fuel Management*. IAEA Nuclear Energy Series No. NF-T-3.8, Vienna, Austria. Available at http://www-pub.iaea.org/MTCD/Publications/PDF/Pub1490_web.pdf.

IAEA (International Atomic Energy Agency). 2011b. *Disposal of Radioactive Wastes Specific Safety Requirements*. SSR-5, Vienna, Austria. Available at: http://www-pub.iaea.org/MTCD/publications/PDF/Pub1449_web.pdf.

IAEA (International Atomic Energy Agency). 2013. *Spent Fuel Storage Operation—Lessons Learned*. IAEA TECDOC Series No. 1725, Vienna, Austria. Available at http://www-pub.iaea.org/MTCD/Publications/PDF/TE-1725_web.pdf.

INPO (Institute of Nuclear Power Operations). 2011. *Special Report on the Nuclear Accident at the Fukushima Dai-ichi Nuclear Power Station*. INPO 11–005, Revision 0, Atlanta, Georgia. Available at <http://www.wano.info/Documents/Lessons%20Learned.pdf>.

In re Aiken County. 725 F.3d 255 (D.C. Cir. 2013).

Appendix B

Johnson, A.B. 1977. *Behavior of Spent Nuclear Fuel in Water Pool Storage*. BNWL-2256, Battelle-Pacific Northwest Laboratories, Richland, Washington. Available at <http://www.ntis.gov/search/product.aspx?ABBR=BNWL2256>.

Johnson, A.B., Jr. 1978. "Utility Spent Fuel Storage Experience." In Schumacher, J.F., ed. *Executive Conference on Spent Fuel Policy and Its Implications*. American Nuclear Society Executive Conference, April 2-5, 1978; Pineisle Resort, Buford, Georgia. University of Wisconsin, Madison, Wisconsin.

MRWS (West Cumbria Managing Radioactive Waste Safely Partnership). 2012. *The Final Report of the West Cumbria Managing Radioactive Waste Safely Partnership*. Copeland Borough Council, Cumbria, United Kingdom. Available at <http://www.westcumbriamrws.org.uk/images/final-report.pdf>.

NAS (National Academy of Sciences). 1995. *Technical Bases for Yucca Mountain Standards*. National Academy of Sciences/National Research Council of Board on Radioactive Waste Management, Committee on the Remediation of Buried and Tank Waste, National Academy Press, Washington, D.C.

NAS (National Academy of Sciences). 2000. *Long-Term Institutional Management of the U.S. Department of Energy Legacy Waste Sites*. National Academy of Sciences/National Research Council of Board on Radioactive Waste Management, Committee on the Remediation of Buried and Tank Waste, National Academy Press, Washington, D.C.

National Environmental Policy Act of 1969 (NEPA), as amended. 42 USC 4321 *et seq.*

NEA (Nuclear Energy Agency). 1997. *Lessons Learnt from Ten Performance Assessment Studies*. Organisation for Economic Co-Operation and Development, Paris, France. Available at <http://www.oecd-nea.org/rwm/reports/1997/ipag.pdf>.

NEA (Nuclear Energy Agency). 2006. *The Roles of Storage in the Management of Long-Lived Radioactive Waste*. Organization for Economic Cooperation and Development, Paris, France. Available at <https://www.oecd-nea.org/rwm/reports/2006/nea6043-storage.pdf>.

NEA (Nuclear Energy Agency). 2012. *The Post-Closure Radiological Safety Case for a Spent Fuel Repository in Sweden*. NEA/RWM/PEER(2012)2. Organization for Economic Cooperation and Development, Paris, France. Available at <http://www.stralsakerhetsmyndigheten.se/Global/Slutförvar/NEA/SSM%202010-4132-95%20Final%20Report%20NEA%20RWM%20PEER%202012%202.pdf%20564893%201%201.pdf>.

New York v. NRC (State of New York et al. v. U.S. Nuclear Regulatory Commission). 681 F.3d 471 (D.C. Cir. 2012). Accession No. ML12191A407.

NRC (U.S. Nuclear Regulatory Commission). 1979. *TMI-2 Lessons Learned Task Force Status Report and Short Term Recommendations*. NUREG-0578. Washington, D.C. Accession No. ML090060030.

NRC (U.S. Nuclear Regulatory Commission). 1980a. *NRC Action Plan Developed as a Result of the TMI-2 Accident*. NUREG-0660, Washington, D.C. Accession Nos. ML072470526, ML072470524.

NRC (U.S. Nuclear Regulatory Commission). 1980b. *TMI-Related Requirements for New Operating Licenses*. NUREG-0694, Washington, D.C. Accession No. ML072500081.

NRC (U.S. Nuclear Regulatory Commission). 1980c. *Clarification of TMI Action Plan Requirements*. NUREG-0737, Washington, D.C. Accession No. ML051400209.

NRC (U.S. Nuclear Regulatory Commission). 1996a. Memorandum from J.M. Taylor to NRC, dated July 26, 1996, regarding "Resolution of Spent Fuel Storage Pool Action Plan Issues." Washington, D.C. Accession No. ML003706364.

NRC (U.S. Nuclear Regulatory Commission). 1996b. Memorandum from J.M. Taylor to NRC, dated October 3, 1996, regarding "Assessment of Spent Fuel Cooling." Washington, D.C. Accession No. ML003706381.

NRC (U.S. Nuclear Regulatory Commission). 1997a. *Operating Experience Feedback Report: Assessment of Spent Fuel Cooling*. NUREG-1275, Volume 12, Washington, D.C. Accession No. ML010670175.

NRC (U.S. Nuclear Regulatory Commission). 1997b. Memorandum from L.J. Callan to NRC dated September 30, 1997, regarding "Followup Activities on the Spent Fuel Pool Action Plan." Washington, D.C. Accession No. ML003706412.

NRC (U.S. Nuclear Regulatory Commission). 2000. Memorandum from J.T. Larkins to G.M. Holohan, dated May 2, 2000, regarding "Resolution of GSI-173, Spent Fuel Pool Cooling for Operating Plants." Washington, D.C. Accession No. ML003710695.

NRC (U.S. Nuclear Regulatory Commission). 2001. *Technical Study of Spent Fuel Pool Accident Risk at Decommissioning Nuclear Power Plants*. NUREG-1738, Washington, D.C. Accession No. ML010430066.

NRC (U.S. Nuclear Regulatory Commission). 2006a. Letter from NRC to J. Parkyn, dated February 21, 2006, regarding "Issuance of Materials License No. SNM-2513 for the Private Fuel Storage Facility (TAC No. L23821)." Washington, D.C. Accession No. ML060450412.

Appendix B

NRC (U.S. Nuclear Regulatory Commission). 2006b. *Liquid Radioactive Release Lessons Learned Task Force Final Report*. Washington, D.C. Accession No. ML062650312.

NRC (U.S. Nuclear Regulatory Commission). 2007. *A Pilot Probabilistic Risk Assessment of a Dry Cask Storage System at a Nuclear Power Plant*. NUREG–1864, Washington, D.C. Accession No. ML071340012.

NRC (U.S. Nuclear Regulatory Commission). 2008. *Minimization of Contamination and Radioactive Waste Generation: Life-Cycle Planning*. Regulatory Guide 4.21, Washington, D.C. Accession No. ML080500187.

NRC (U.S. Nuclear Regulatory Commission). 2009a. *Degradation of Neutron-Absorbing Materials in the Spent Fuel Pool*. IN 2009–26, Washington, D.C. Accession No. ML092440545.

NRC (U.S. Nuclear Regulatory Commission). 2009b. “Radiological Environmental Monitoring For Nuclear Power Plants.” Regulatory Guide 4.1, Revision 2, Washington, D.C. Accession No. ML091310141.

NRC (U.S. Nuclear Regulatory Commission). 2010a. *U.S. Department of Energy’s Motion to Withdraw [Yucca Mountain]*. ASLBP No. 09–892–HLW–CAB04., Washington, D.C. Accession No. ML100621397.

NRC (U.S. Nuclear Regulatory Commission). 2010b. *Safety Evaluation Report Related to Disposal of High-Level Radioactive Wastes in a Geologic Repository at Yucca Mountain, Nevada—Volume 1: General Information*. NUREG–1949, Volume 1, Washington, D.C. Accession No. ML102440298.

NRC (U.S. Nuclear Regulatory Commission). 2010c. *Standard Review Plan for Spent Fuel Dry Storage Systems at a General License Facility*. NUREG–1536, Revision 1, Washington, D.C. Accession No. ML101040620.

NRC (U.S. Nuclear Regulatory Commission). 2010d. *Groundwater Task Force Final Report*. Washington, D.C. Accession No. ML101740509.

NRC (U.S. Nuclear Regulatory Commission). 2011a. *Technical Evaluation Report on the Content of the U.S. Department of Energy’s Yucca Mountain Repository License Application—Preclosure Volume: Repository Safety Before Permanent Closure*. NUREG–2108, Washington, D.C. Accession No. ML11250A093.

NRC (U.S. Nuclear Regulatory Commission). 2011b. *Technical Evaluation Report on the Content of the U.S. Department of Energy's Yucca Mountain Repository License Application—Postclosure Volume: Repository Safety After Permanent Closure*. NUREG–2107, Washington, D.C. Accession No. ML11223A273.

NRC (U.S. Nuclear Regulatory Commission). 2011c. *Technical Evaluation Report on the Content of the U.S. Department of Energy's Yucca Mountain Repository License Application—Administrative and Programmatic Volume*. NUREG–2109, Washington, D.C. Accession No. ML11255A002.

NRC (U.S. Nuclear Regulatory Commission). 2011d. *Senior Management Review of Overall Regulatory Approach to Groundwater Protection*. SECY–11–0019, Washington, D.C. Accession No. ML12338A692.

NRC (U.S. Nuclear Regulatory Commission). 2012a. Letter to All Power Reactor Licensees and Holder of Construction Permits in Active or Deferred Status, dated March 12, 2012, regarding “Request for Information Pursuant to Title 10 of the *Code of Federal Regulations* 50.54(f) Regarding Recommendations 2.1, 2.3, and 9.3, of the Near-Term Task Force Review of Insights from the Fukushima Dai-Ichi Accident.” Washington, D.C. Accession No. ML12053A340.

NRC (U.S. Nuclear Regulatory Commission). 2012b. *Potential Chloride-Induced Stress Corrosion Cracking of Austenitic Stainless Steel and Maintenance of Dry Cask Storage System Canisters*. IN 2012–20, Washington, D.C. Accession No. ML12319A440.

NRC (U.S. Nuclear Regulatory Commission). 2012c. *Decommissioning Planning During Operations*. Regulatory Guide 4.22, Washington, D.C. Accession No. ML12158A361.

NRC (U.S. Nuclear Regulatory Commission). 2012d. “Inspection Program for Dry Storage of Spent Reactor Fuel at Independent Spent Fuel Storage Installations and for 10 CFR Part 71 Transportation Packages.” Chapter 2690 in *NRC Inspection Manual*. Washington, D.C. Accession No. ML120390415.

NRC (U.S. Nuclear Regulatory Commission). 2013. “Memorandum and Order in the Matter of U.S Department of Energy (High Level Waste Repository).” CLI-13-08, Rockville, Maryland. Accession No. ML13322A744.

NRC (U.S. Nuclear Regulatory Commission). 2014. *Identification and Prioritization of the Technical Information Needs Affecting Potential Regulation of Extended Storage and Transportation of Spent Nuclear Fuel*. Washington, D.C. Accession No. ML14043A423.

Nuclear Waste Policy Act of 1982 (NWPA), as amended. 42 USC 10101 *et seq.*

Appendix B

NWMO (Nuclear Waste Management Organization). 2008. *Annual Report 2007: Moving Forward Together*. Toronto, Ontario. Available at http://www.nwmo.ca/uploads_managed/MediaFiles/327_NWMO_2007_Annual_Report_E.pdf.

NWMO (Nuclear Waste Management Organization). 2013. *Annual Report 2012: Learning More Together*. Toronto, Ontario. Available at http://www.nwmo.ca/uploads_managed/MediaFiles/2089_ar2012_english_web.pdf.

Sindelar, R.L., A.J. Duncan, M.E. Dupont, P.-S. Lam, M.R. Louthan, Jr., and T.E. Skidmore. 2011. *Materials Aging Issues and Aging Management for Extended Storage and Transportation of Spent Nuclear Fuel*. NUREG/CR-7116, Savannah River National Laboratory, Aiken, South Carolina. Accession No. ML11321A182.

Travis, R.J., R.E. Davis, E.J. Grove, and M.A. Azarm. 1997. *Safety and Regulatory Assessment of Generic BWR and PWR Permanently Shutdown Nuclear Power Plants*. NUREG/CR-6451, Brookhaven National Laboratory, Upton, New York. Accession No. ML082260098.

VEPCO (Virginia Electric and Power Company). 2011. *Virginia Electric and Power Company (Dominion) North Anna Power Station Units 1 and 2 North Anna Independent Spent Fuel Storage Installation Summary Report of August 23, 2011 Earthquake Response and Restart Readiness Determination Plan*. Richmond, Virginia. Accession No. ML11262A151.

Walker, J.F. 1979. *Long-Term Storage of Irradiated CANDU Fuel Under Water*. Whiteshell Nuclear Research Establishment, Pinawa, Manitoba. Available at <http://www.ntis.gov/search/product.aspx?ABBR=N7932999>.

Appendix C

Outreach and Correspondence

Appendix C

Outreach and Correspondence

This appendix provides a description of outreach activities and agencies and groups that the U.S. Nuclear Regulatory Commission (NRC) contacted during the preparation of this *Generic Environmental Impact Statement for Continued Storage of Spent Nuclear Fuel* (GEIS), and a listing of correspondence related to the NRC's environmental review. The NRC did not identify any cooperating agencies for the environmental review or receive any formal requests for cooperating agency status.

C.1 Outreach

The NRC staff conducted extensive outreach efforts during the preparation of the GEIS and Rule.

WCOUTREACH E-mail: The NRC staff used an e-mail account, WCO outreach@nrc.gov, to distribute information to subscribers regarding Waste Confidence. Through this e-mail account, the NRC staff provided periodic updates on activities, links to new information published in the NRC's Agencywide Document Access and Management Systems (ADAMS), and links to information on the NRC website. On October 25, 2012, when the NRC staff e-mailed the scoping notice to subscribers, the NRC's WCO outreach@nrc.gov e-mail distribution list consisted of approximately 1,050 individuals, including individuals who expressed interest in previous spent nuclear fuel (spent fuel) studies and efforts; members of the public on mailing lists for new reactor and license renewal environmental reviews; representatives from Federal, Tribal, State, and local governments; and representatives from industry and public advocacy groups and environmental organizations. In the months following publication of the draft GEIS and proposed Rule, the e-mail distribution list expanded to approximately 3,200 subscribers.

Public Meetings and Webinars: During the 70-day scoping comment period, the NRC conducted two webcast public scoping meetings and two webinars. The meetings and webinars each began with a slide presentation by NRC staff, which was followed by a question-and-answer period and a block of time dedicated to listening to and transcribing public scoping comments. During the 98-day public comment period on the draft GEIS and proposed Rule, the NRC conducted 13 public meetings on the draft documents. More information on the public comment period and meetings for the draft GEIS and proposed Rule can be found in Appendix D. Notices for all public meetings were published in the *Federal Register*, e-mailed, posted on the NRC website, and advertised by the NRC's Office of Public Affairs through press releases.

Appendix C

NRC Website: Throughout the rulemaking process, the NRC maintained a Waste Confidence webpage at www.nrc.gov/waste/spent-fuel-storage/wcd.html. The NRC regularly updated the website, which contained a specific section titled “Public Involvement in Waste Confidence,” with related documents, new information, and frequently asked questions. The NRC will not maintain the Waste Confidence webpage after the revised Rule becomes effective. All documents posted on the Waste Confidence webpage are publicly available and all official agency records will continue to be available in ADAMS.

Monthly Status Update Public Teleconferences: In the months following closure of the scoping period and through publication of the draft GEIS, the NRC staff held monthly public status teleconferences to provide an update on activities related to the Waste Confidence rulemaking and GEIS. One final teleconference was held following the closure of the draft GEIS and proposed Rule comment period. These were Category 3 meetings (the type of NRC meetings where public participation is actively sought)—the public was invited to attend via telephone and ask questions of the NRC staff. Status update teleconferences were for informational purposes only and any comments made and questions asked during the teleconferences were not counted as comments on draft GEIS and proposed Rule. Transcripts and summaries of the teleconferences were posted to the Waste Confidence Directorate “Public Involvement in Waste Confidence” webpage and are available in ADAMS.

Tribal Contact: The scoping notice was mailed and e-mailed, when possible, to all Federally recognized Native American Tribes (1) located within 80 km (50 mi) of a nuclear power plant, (2) registered with the NRC for advance notification of shipments of irradiated reactor fuel and nuclear waste under Title 10 of the *Code of Federal Regulations* (CFR) Parts 71 and 73; or (3) previously expressing interest in the NRC’s Yucca Mountain application activities (see ADAMS Accession No. ML12311A464 for an example of the Tribal outreach letter that transmitted the scoping notice and the tribal distribution list). Fifty-eight Tribal contacts were mailed a copy of the Waste Confidence scoping notice. In addition, the NRC corresponded with the Northern Chumash Tribal Council (recognized by the state of California) and the Santa Ynez Band of Chumash Indians (Federally recognized), which are both located near the Diablo Canyon Nuclear Plant.

The NRC also distributed the draft GEIS, proposed Rule, and public meeting notices to Tribal contacts. A CD-ROM copy of the draft GEIS, a hardcopy of the proposed Rule, and public meeting information was mailed to 76 Tribal contacts, and e-mail notification of the upcoming NRC mailing was also sent to those contacts with e-mail addresses. See ADAMS Accession No. ML13259A130 for an example of the Tribal outreach letter that transmitted the draft GEIS, proposed Rule, and public meeting information.

The NRC also initiated government-to-government consultation with the Prairie Island Indian Community. The Prairie Island Indian reservation is located adjacent to the Prairie Island Nuclear Generating Plant in Welch, Minnesota. Government-to-government meetings were

held between the NRC and Tribal representatives on June 13, 2013 and December 5, 2013. The Prairie Island Indian Community provided both oral and written comments during both the scoping and draft GEIS and proposed Rule comment periods.

State Contact: The NRC provided the scoping notice and notice of publication of the draft GEIS, proposed Rule, and scheduled public comment meetings to state liaison officers in all agreement and nonagreement states. The NRC also provided notification of the public status teleconferences.

U.S. Environmental Protection Agency (EPA) Contact: The NRC met with representatives of the EPA on November 5, 2012. The purpose of the meeting was to provide historical information on the Waste Confidence rule, to discuss the status of the environmental review and rulemaking, to discuss how the NRC was conducting new reactor and license renewal reviews in the interim while Waste Confidence was addressed, and to receive advice on the NRC's approach. The EPA provided comments on the scope of the GEIS (Accession No. ML13028A469) and comments on the proposed Rule and draft GEIS (Accession No. ML14016A089).

C.2 Correspondence

This section contains a chronological listing of correspondence related to the NRC's environmental review in preparation of this GEIS. The documents listed below can be found online through ADAMS at <http://www.nrc.gov/reading-rm/adams.html>. The ADAMS accession numbers for each document are included below.

October 24, 2012	NRC to Hold Public Scoping Meetings for Waste Confidence Environmental Study Nov. 14 in Rockville, MD. Press Release No. 12-119. Accession No. ML12298A295.
October 25, 2012	<i>Federal Register</i> Notice of Intent to Prepare an Environmental Impact Statement and Notice of Public Meetings. 77 FR 65137. Accession No. ML12312A178.
October 25, 2012	E-mail from WCO Outreach@nrc.gov, <i>Federal Register</i> Notice (77 FRN 65137) for Waste Confidence EIS and Scoping. Accession No. ML13120A477.
October 31, 2012	Forthcoming Waste Confidence Scoping Meetings for the Environmental Impact Statement (November 14, 2012). Accession No. ML12306A224.

Appendix C

- October 31, 2012 Notification of the Scoping Process for the Environmental Impact Statement for the Waste Confidence Decision and Rule Update and Notice of Public Meetings and Webinars (FSME–12–085). Accession No. ML12293A107.
- November 6, 2012 E-mail from WCO outreach@nrc.gov, Link to Meeting Notice for Nov. 14 Waste Confidence Scoping Meetings. Accession No. ML13120A483.
- November 8, 2012 E-mail from WCO outreach@nrc.gov, *Federal Register* Notice (77 FRN 65137) for Waste Confidence EIS and Scoping—and Nov. 14 Public Meeting Notice. Accession No. ML13120A481.
- November 8, 2012 Letter to NRC Commissioners, from G. Fettus, M. Goldstein, and D. Curran, Notice of Intent to Prepare Waste Confidence EIS. Accession No. ML12314A345.
- November 13, 2012 Letter to NRC Commissioners, from D. Brancato, Riverkeeper, Waste Confidence Scoping Meetings and Opportunity to Comment. Accession No. ML13184A154.
- November 13, 2012 E-mail from WCO outreach@nrc.gov, Direct Comment Link and Waste Confidence Scoping Meeting Slides. Accession No. ML13120A478.
- November 21, 2012 Forthcoming Webinars for the Environmental Impact Statement to Support an Updated Waste Confidence Decision and Rule (December 5 and 6, 2012). Accession No. ML12326A911.
- November 27, 2012 E-mail from WCO outreach@nrc.gov, Upcoming December 5 and 6 Waste Confidence Webinars. Accession No. ML13120A479.
- November 28, 2012 Letter to NRC Commissioners, from F. Collins, Tribal Administrator, Northern Chumash Tribal Council, Notice of Intent to Prepare Waste Confidence EIS. Accession No. ML13184A149.
- December 5, 2012 Letter to D. Curran, Harmon, Curran, Spielberg & Eisenberg, L.L.P., from A. Macfarlane, Chairman, NRC, regarding the Waste Confidence Scoping Process. Accession No. ML12319A309. (Identical letters sent to G. Fettus and M. Goldstein.)
- December 6, 2012 Summary of Public Scoping Meetings for Environmental Impact Statement to Support Waste Confidence Rulemaking (November 14, 2012). Accession No. ML12339A281.
- December 26, 2012 Summary of Public Scoping Webinars for the Environmental Impact Statement to Support the Waste Confidence Rulemaking (December 5 and 6, 2012). Accession No. ML12356A293.

December 31, 2012 E-mail from WCO Outreach@nrc.gov, Waste Confidence Scoping Meeting Summaries and Transcripts. Accession No. ML13120A480.

December 31, 2012 Notice of Forthcoming Public Teleconference to Discuss Status of Waste Confidence Environmental Impact Statement and Rulemaking (January 16, 2013). Accession No. ML12366A201.

January 2, 2013 Letter to F. Collins, Tribal Administrator, Northern Chumash Tribal Council, from K. McConnell, Director, Waste Confidence Directorate, NRC, regarding the Waste Confidence Scoping Process. Accession No. ML13002A221.

January 6, 2013 Letter to NRC Commissioners, from S. Cohen, Government and Legal Specialist, Santa Ynez Band of Chumash Indians, Notice of Intent to Prepare Waste Confidence EIS. Accession No. ML130500419.

January 9, 2013 E-mail from WCO Outreach@nrc.gov, Waste Confidence Monthly Public Teleconferences. Accession No. ML13120A484.

January 11, 2013 Letter to S. Cohen, Government and Legal Specialist, Santa Ynez Band of Chumash Indians, from K. McConnell, Director, Waste Confidence Directorate, NRC, regarding the Waste Confidence Scoping Process. Accession No. ML13011A015.

January 11, 2013 Notice of Forthcoming Public Teleconference to Discuss Status of Waste Confidence Environmental Impact Statement and Rulemaking (FSME-13-003). Accession No. ML13011A150.

January 31, 2013 Summary of Public Teleconference to Discuss Status of Waste Confidence Environmental Impact Statement and Rulemaking (January 16, 2013). Accession No. ML13032A100.

January 31, 2013 Notice of Forthcoming Public Teleconference to Discuss Status of Waste Confidence Environmental Impact Statement and Rulemaking (February 20, 2013). Accession No. ML13031A063.

February 5, 2013 Notice of Forthcoming Public Teleconference to Discuss Status of Waste Confidence Environmental Impact Statement and Rulemaking (FSME-13-016). Accession No. ML13032A152.

February 5, 2013 E-mail from WCO Outreach@nrc.gov, Waste Confidence teleconference meeting summary, transcript and upcoming meeting. Accession No. ML13120A475.

Appendix C

March 1, 2013	Summary of Public Teleconference to Discuss Status of Waste Confidence Environmental Impact Statement and Rulemaking (February 20, 2013). Accession No. ML13060A105.
March 4, 2013	Summary Report for the Waste Confidence Generic Environmental Impact Statement Scoping Process. Accession No. ML13060A136.
March 5, 2013	E-mail from WCO Outreach@nrc.gov, Waste Confidence scoping summary report and upcoming teleconference information. Accession No. ML13120A476.
March 5, 2013	Notice of Forthcoming Public Teleconference to Discuss Status of Waste Confidence Generic Environmental Impact Statement and Rulemaking (March 20, 2013). Accession No. ML13063A465.
March 8, 2013	Letter to K. McConnell and A. Imboden, Waste Confidence Directorate, NRC, from D. Brancato, Riverkeeper, NRC Waste Confidence Update—Request for Public Meeting. Accession No. ML13102A054.
March 8, 2013	Notice of Forthcoming Public Teleconference to Discuss Status of Waste Confidence Environmental Impact Statement and Rulemaking (FSME-13-024). Accession No. ML13063A491.
March 28, 2013	Notice of Forthcoming Public Teleconference to Discuss Status of Waste Confidence Generic Environmental Impact Statement and Rulemaking (April 17, 2013). Accession No. ML13087A363.
April 5, 2013	Summary of Public Teleconference to Discuss Status of Waste Confidence Environmental Impact Statement and Rulemaking (March 20, 2013). Accession No. ML13095A362.
April 5, 2013	Notice of Forthcoming Public Teleconference to Discuss Status of Waste Confidence Environmental Impact Statement and Rulemaking (FSME-13-034). Accession No. ML13091A344.
April 11, 2013	E-mail from WCO Outreach@nrc.gov, Upcoming April public teleconference and March meeting summary and transcript. Accession No. ML13120A482.
May 2, 2013	Summary of Public Teleconference to Discuss Status of Waste Confidence Environmental Impact Statement and Rulemaking (April 17, 2013). Accession No. ML13122A097.

May 6, 2013 Notice of Forthcoming Public Teleconference to Discuss Status of Waste Confidence Generic Environmental Impact Statement and Rulemaking (May 29, 2013). Accession No. ML13127A380.

May 8, 2013 E-mail from WCO Outreach@nrc.gov, Waste Confidence April 17 meeting summary and transcript, and May 29 meeting notice. Accession No. ML13128A508.

May 14, 2013 Notice of Forthcoming Public Teleconference to Discuss Status of Waste Confidence Generic Environmental Impact Statement and Rulemaking (FSME-13-044). Accession No. ML13133A072.

May 14, 2013 Letter to D. Brancato, Riverkeeper, from K. McConnell, NRC, regarding NRC Waste Confidence Update—Request for Public Meeting. Accession No. ML13126A214.

May 23, 2013 Letter to NRC Commissioners, from K. Landis-Marinello, Assistant Attorney General, State of Vermont, States' Petition for Review of NRC Staff Scoping Decision, Spent Fuel Storage EIS (RIN 3150-AJ20; NRC-2012-0246). Accession No. ML13149A446.

May 24, 2013 Letter to A. Vietti-Cook, Secretary of the Commission, NRC, from K. Landis-Marinello, Assistant Attorney General, State of Vermont, Distributing States' Petition for Review of NRC Staff Scoping Decision; Spent Fuel Storage EIS (RIN 3150-AJ20; NRC-2012-0246). Accession No. ML13149A446.

May 30, 2013 Notice of Forthcoming Public Teleconference to Discuss Status of Waste Confidence Generic Environmental Impact Statement and Rulemaking (June 19, 2013). Accession No. ML13150A263.

June 4, 2013 Notice of Forthcoming Public Teleconference to Discuss Status of Waste Confidence Generic Environmental Impact Statement and Rulemaking (FSME-13-053). Accession No. ML13154A434.

June 6, 2013 Summary of Public Teleconference to Discuss Status of Waste Confidence Generic Environmental Impact Statement and Rulemaking (May 29, 2013). Accession No. ML13158A024.

June 13, 2013 E-mail from WCO Outreach@nrc.gov, Waste Confidence June 19th status teleconferencing notice, and May 29th meeting summary and transcript. Accession No. ML13171A353.

Appendix C

June 24, 2013	E-mail from WCO Outreach@nrc.gov, Waste Confidence Commission review draft documents now available. Accession No. ML13175A390.
July 17, 2013	E-mail from WCO Outreach@nrc.gov, Waste Confidence June 19 th Status Teleconference Meeting Summary and Transcript. Accession No. ML13219A201.
July 23, 2013	Notice of Forthcoming Public Teleconference to Discuss Status of Waste Confidence Generic Environmental Impact Statement and Rulemaking (August 14, 2013). Accession No. ML13205A393.
July 23, 2013	Letter to W. Sorrell, Attorney General, State of Vermont, from A. Macfarlane, Chairman, NRC, regarding the Petition for Review of Staff Scoping Decision. Accession No. ML13204A315. (Identical letters sent to D. Springer, G. Jepsen, M. Coakley, and E. Schneiderman.)
July 31, 2013	Notice of Forthcoming Public Teleconference to Discuss Status of Waste Confidence Generic Environmental Impact Statement and Rulemaking (FSME-13-075). Accession No. ML13211A429.
August 5, 2013	E-mail from WCO Outreach@nrc.gov, Commission Approves Publication of Proposed Waste Confidence Rule and Draft Generic EIS. Accession No. ML13219A211.
August 20, 2013	Letter to A. Macfarlane, Chairman, NRC, from D. Kraft, Director, Nuclear Energy Information Service, regarding TIME SENSITIVE—request for NRC to hold waste confidence meeting in Chicago. Accession No. ML13233A338.
August 21, 2013	Summary of August Public Teleconference to Discuss Status of Waste Confidence Generic Environmental Impact Statement and Rulemaking (August 14, 2013). Accession No. ML13234A111.
August 22, 2013	Notice of Forthcoming Public Teleconference to Discuss Status of Waste Confidence Generic Environmental Impact Statement and Rulemaking (September 12, 2013). Accession No. ML13234A172.
August 29, 2013	Letter to D. Kraft, Director, Nuclear Energy Information Service, from A. Vietti-Cook, Secretary of the Commission, NRC, regarding letter to Chairman A. Macfarlane dated August 20, 2013. Accession No. ML13241A442.

September 3, 2013 Notice of Public Meeting to Receive Comments on the Waste Confidence Draft Generic Environmental Impact Statement and Proposed Rule (Rockville, MD; October 1, 2013). Accession No. ML13246A472.

September 3, 2013 Notice of Public Meeting to Receive Comments on the Waste Confidence Draft Generic Environmental Impact Statement and Proposed Rule (Denver, CO; October 3, 2013). Accession No. ML13246A461.

September 4, 2013 Letter to Senator B. Boxer, Chairman, Committee on Environment and Public Works, U.S. Senate, from A. Powell, Office of Congressional Affairs, NRC, regarding Waste Confidence Draft Generic Environmental Impact Statement and Proposed Rule. Accession No. ML13226A075. (Identical letters sent to Senators F. Upton, E. Whitfield, J. Shimkus, and T. Carper, with cc to Representatives H. Waxman, B. Rush, P. Tonko, and J. Sessions.)

September 4, 2013 E-mail from WCO Outreach@nrc.gov, Important Waste Confidence Public Participation Information. Accession No. ML14141A172.

September 5, 2013 NRC Schedules 12 Meetings Nationwide on Waste Confidence Proposed Rule and Environmental Study. Press Release No. 13-072. Accession No. ML13248A595.

September 5, 2013 Notice of Public Meeting to Receive Comments on the Waste Confidence Draft Generic Environmental Impact Statement and Proposed Rule (San Luis Obispo, CA; October 7, 2013—postponed). Accession No. ML13248A323.

September 5, 2013 Notice of Public Meeting to Receive Comments on the Waste Confidence Draft Generic Environmental Impact Statement and Proposed Rule (Carlsbad, CA; October 9, 2013—postponed). Accession No. ML13248A338.

September 5, 2013 Notice of Forthcoming Public Teleconference to Discuss Status of Waste Confidence Generic Environmental Impact Statement and Rulemaking (FSME-13-090). Accession No. ML13246A465.

September 6, 2013 *Federal Register* Notice of public meetings, Proposed Waste Confidence Rule and Draft Generic Environmental Impact Statement. 78 FR 54789. Accession No. ML14141A269.

Appendix C

- September 6, 2013 E-mail from WCO outreach@nrc.gov, Waste Confidence Draft Generic Environmental Impact Statement now available. Accession No. ML14141A173.
- September 6, 2013 Notice of Public Meeting to Receive Comments on the Waste Confidence Draft Generic Environmental Impact Statement and Proposed Rule (Perrysburg, OH; October 15, 2013—postponed). Accession No. ML13249A443.
- September 6, 2013 Notice of Public Meeting to Receive Comments on the Waste Confidence Draft Generic Environmental Impact Statement and Proposed Rule (Minnetonka, MN; October 17, 2013—postponed). Accession No. ML13249A536.
- September 6, 2013 Notice of Public Meeting to Receive Comments on the Waste Confidence Draft Generic Environmental Impact Statement and Proposed Rule (Chelmsford, MA; October 28, 2013). Accession No. ML13249A570.
- September 6, 2013 Notice of Public Meeting to Receive Comments on the Waste Confidence Draft Generic Environmental Impact Statement and Proposed Rule (Tarrytown, NY; October 30, 2013). Accession No. ML13249A567.
- September 6, 2013 Notice of Public Meeting to Receive Comments on the Waste Confidence Draft Generic Environmental Impact Statement and Proposed Rule (Charlotte, NC; November 4, 2013). Accession No. ML13249A545.
- September 6, 2013 Notice of Public Meeting to Receive Comments on the Waste Confidence Draft Generic Environmental Impact Statement and Proposed Rule (Orlando, FL; November 6, 2013). Accession No. ML13249A559.
- September 6, 2013 Notice of Public Meeting to Receive Comments on the Waste Confidence Draft Generic Environmental Impact Statement and Proposed Rule (Rockville, MD; November 14, 2013). Accession No. ML13249A563.

- September 6, 2013 Notice of Public Meeting to Receive Comments on the Waste Confidence Draft Generic Environmental Impact Statement and Proposed Rule (Oak Brook, IL; October 24, 2013—postponed). Accession No. ML13249A565.
- September 12, 2013 NRC Seeks Public Comment on Proposed Rule and Environmental Study of Extended Storage of Spent Nuclear Fuel. Press Release No. 13-077. Accession No. ML13255A379.
- September 13, 2013 *Federal Register* Notice of proposed rule, Waste Confidence—Continued Storage of Spent Nuclear Fuel. 78 FR 56776. Accession No. ML13256A004.
- September 13, 2013 *Federal Register* Notice of draft generic environmental impact statement; public meetings and request for comment, Draft Waste Confidence Generic Environmental Impact Statement. 78 FR 56621. Accession No. ML14141A270.
- September 13, 2013 Opportunity to Comment on Draft Generic Environmental Impact Statement and Proposed Rule to Amend 10 CFR Part 51—Waste Confidence—Continued Storage of Spent Nuclear Fuel (FSME-13-094). Accession No. ML13256A133.
- September 13, 2013 E-mail from WCO outreach@nrc.gov, Announcing the start of the Waste Confidence public comment period. Accession No. ML14141A174.
- September 16, 2013 Letter to F. Collins, Tribal Administrator, Northern Chumash Tribal Council, from K. McConnell, Waste Confidence Directorate, NRC, Opportunity to Comment on Draft Generic Environmental Impact Statement and Proposed Rule to Amend 10 CFR 51.23—Waste Confidence—Continued Storage of Spent Nuclear Fuel. Accession No. ML13259A130. (Identical letters sent to 75 additional Tribal contacts and the National Congress of American Indians.)
- September 18, 2013 E-mail from S. Lopas, Waste Confidence Directorate, NRC, Notification of upcoming Nuclear Regulatory Commission mailing. Accession No. ML14140A713. (E-mail sent to 56 Tribal contacts.)
- September 19, 2013 *Federal Register* Notice of public meetings, Proposed Waste Confidence Rule and Draft Generic Environmental Impact Statement. 78 FR 57538. Accession No. ML14160B249.

Appendix C

- September 19, 2013 Letter to A. Macfarlane, NRC, from Representative H. Johnson, U.S. House of Representatives, regarding request for a Waste Confidence public meeting in Atlanta, Georgia. Accession No. ML13263A063.
- September 24, 2013 Summary of September Public Teleconference to Discuss Status of Waste Confidence Generic Environmental Impact Statement and Rulemaking (September 12). Accession No. ML13267A384.
- September 25, 2013 E-mail from WCO Outreach@nrc.gov, Confirming our October 3 Denver meeting and meeting registration instructions. Accession No. ML14141A175.
- September 30, 2013 E-mail from WCO Outreach@nrc.gov, This week's Waste Confidence meetings will be held. Accession No. ML14141A177.
- October 4, 2013 E-mail from WCO Outreach@nrc.gov, Waste Confidence California Meetings have been Postponed. Accession No. ML14141A163.
- October 4, 2013 NRC Postpones California Meetings on Waste Confidence Because of Government Shutdown. Press Release No. 13-083. Accession No. ML13277A694.
- October 4, 2013 Letter to A. Macfarlane, Chairman, NRC, from D. Curran, Harmon, Curran, Spielberg & Eisenberg, L.L.P., regarding Government Shutdown and Waste Confidence Meetings. Accession No. ML13281A829. (Identical letter sent to M. Goldstein.)
- October 7, 2013 Letter to Secretary, Commissioners, NRC, from M. Olson, Nuclear Information and Resource Service, Southeast, regarding Public Comment on the GEIS on Waste Confidence, NUREG 2157, and proposed Waste Confidence Rule, 10CFR51. Accession No. ML13281A840.
- October 9, 2013 Summary of October 1 Public Meeting in Rockville, Maryland, to Receive Comments on the Waste Confidence Draft Generic Environmental Impact Statement and Proposed Rule. Accession No. ML13282A611.
- October 9, 2013 E-mail from WCO Outreach@nrc.gov, POSTPONED: Perrysburg and Minnetonka Waste Confidence Meetings. Accession No. ML14141A166.

October 9, 2013 E-mail from WCO Outreach@nrc.gov, POSTPONED: Oak Brook Waste Confidence Meeting. Accession No. ML14141A165.

October 9, 2013 NRC Postpones Ohio, Minnesota Meetings on Waste Confidence Because of Government Shutdown. Press Release No. 13-085. Accession No. ML13282A511.

October 18, 2013 Notice of Public Meeting to Receive Comments on the Waste Confidence Draft Generic Environmental Impact Statement and Proposed Rule (Oak Brook, IL; November 12, 2013—new date). Accession No. ML13291A322.

October 18, 2013 Notice of Public Meeting to Receive Comments on the Waste Confidence Draft Generic Environmental Impact Statement and Proposed Rule (Carlsbad, CA; November 18, 2013—new date). Accession No. ML13294A063.

October 18, 2013 Notice of Public Meeting to Receive Comments on the Waste Confidence Draft Generic Environmental Impact Statement and Proposed Rule (San Luis Obispo, CA; November 20, 2013—new date). Accession No. ML13294A065.

October 18, 2013 Notice of Forthcoming Public Teleconference to Discuss Status of Waste Confidence Generic Environmental Impact Statement and Rulemaking (October 30, 2013). Accession No. ML13291A153.

October 21, 2013 E-mail from WCO Outreach@nrc.gov, Announcing new dates for Oak Brook, Carlsbad, and San Luis Obispo meetings. Accession No. ML14141A167.

October 22, 2013 Summary of October 3 Public Meeting in Denver, Colorado, to Receive Comments on the Waste Confidence Draft Generic Environmental Impact Statement and Proposed Rule. Accession No. ML13295A427.

October 23, 2013 Letter to Representative H. Johnson, U.S. House of Representatives, from A. Macfarlane, Chairman, NRC, regarding letter dated September 19, 2013, requesting a Waste Confidence public meeting in Atlanta, Georgia. Accession No. ML13274A550.

October 25, 2013 NRC Schedules Nov. 4 Meeting in Charlotte to Take Comments on Proposed Spent Nuclear Fuel Rule and Environmental Study. Press Release No. II-13-059. Accession No. ML13298A873.

Appendix C

October 25, 2013	Notice of Public Meeting to Receive Comments on the Waste Confidence Draft Generic Environmental Impact Statement and Proposed Rule (Perrysburg, OH; December 2, 2013—new date). Accession No. ML13298A120.
October 25, 2013	Notice of Public Meeting to Receive Comments on the Waste Confidence Draft Generic Environmental Impact Statement and Proposed Rule (Minnetonka, MN; December 4, 2013—new date). Accession No. ML13298A118.
October 28, 2013	NRC Extends Public Comment Period for Proposed Rule and Environmental Study on Extended Storage of Spent Nuclear Fuel. Press Release No. 13-089. Accession No. ML13301A723.
October 28, 2013	NRC Schedules Nov. 6 Meeting in Orlando to Take Comments on Proposed Spent Nuclear Fuel Rule and Environmental Study. Press Release No. II-13-060. Accession No. ML13301A733.
October 28, 2013	E-mail from WCO Outreach@nrc.gov, Waste Confidence comment period extension and important public meeting information. Accession No. ML14141A170.
October 28, 2013	Letter to B. Rafter, Executive Director, Georgia Women's Action for New Directions, from K. McConnell, Waste Confidence Directorate, NRC, regarding Request for Waste Confidence Public Meeting in Atlanta. Accession No. ML13277A374.
October 29, 2013	<i>Federal Register</i> Notice of rescheduling of public meeting, Proposed Waste Confidence Rule and Draft Generic Environmental Impact Statement. 78 FR 64412. Accession No. ML14141A272.
October 29, 2013	<i>Federal Register</i> Notice of rescheduling of public meetings, Proposed Waste Confidence Rule and Draft Generic Environmental Impact Statement. 78 FR 64413. Accession No. ML14141A266.
October 29, 2013	Notice of Public Teleconference to Receive Comments on the Waste Confidence Draft Generic Environmental Impact Statement and Proposed Rule (December 9, 2013). Accession No. ML13302B935.
October 31, 2013	E-mail from WCO Outreach@nrc.gov, Important correction for Waste Confidence December 9th teleconference. Accession No. ML14141A171.

- November 4, 2013 *Federal Register* Notice of rescheduling of public meetings, Proposed Waste Confidence Rule and Draft Generic Environmental Impact Statement. 78 FR 65903. Accession No. ML14141A267.
- November 5, 2013 Letter to D. Curran, Harmon, Curran, Spielberg & Eisenberg, L.L.P., from A. Macfarlane, Chairman, NRC, regarding Government Shutdown and Waste Confidence Meetings. Accession No. ML13281A773.
- November 7, 2013 *Federal Register* Notice of proposed rule, extension of comment period, Waste Confidence—Continued Storage of Spent Nuclear Fuel. 78 FR 66858. Accession No. ML14141A271.
- November 18, 2013 E-mail from WCO Outreach@nrc.gov, Availability of transcripts, meeting handouts and the remaining public meetings. Accession No. ML14141A162.
- November 19, 2013 Summary of October 28 Public Meeting in Chelmsford, Massachusetts, to Receive Comments on the Waste Confidence Draft Generic Environmental Impact Statement and Proposed Rule. Accession No. ML13323B497.
- November 19, 2013 Summary of October 30 Public Meeting in Tarrytown, New York, to Receive Comments on the Waste Confidence Draft Generic Environmental Impact Statement and Proposed Rule. Accession No. ML13323B515.
- November 19, 2013 Summary of October Public Teleconference to Discuss Status of Waste Confidence Generic Environmental Impact Statement and Rulemaking. Accession No. ML13323B491.
- November 27, 2013 Summary of November 4 Public Meeting in Charlotte, North Carolina, to Receive Comments on the Waste Confidence Draft Generic Environmental Impact Statement and Proposed Rule. Accession No. ML13331A719.
- November 27, 2013 Summary of November 6 Public Meeting in Orlando, Florida, to Receive Comments on the Waste Confidence Draft Generic Environmental Impact Statement and Proposed Rule. Accession No. ML13331A720.

Appendix C

- December 10, 2013 Summary of November 12 Public Meeting in Oak Brook, Illinois, to Receive Comments on the Waste Confidence Draft Generic Environmental Impact Statement and Proposed Rule. Accession No. ML13343A161.
- December 12, 2013 Summary of November 14 Public Meeting in Rockville, Maryland, to Receive Comments on the Waste Confidence Draft Generic Environmental Impact Statement and Proposed Rule. Accession No. ML13346A905.
- December 12, 2013 E-mail from WCO outreach@nrc.gov, Availability of Meeting Summaries and Transcripts. Accession No. ML14141A178.
- December 17, 2013 E-mail from WCO outreach@nrc.gov, Reminder: Waste Confidence public comment period closes this Friday, December 20. Accession No. ML14141A179.
- December 17, 2013 Letter to A. Macfarlane, Chairman, NRC, from B. Gibson, Board of Supervisors, San Luis Obispo County, regarding Waste Confidence Rule and Diablo Canyon Power Plant. Accession No. ML14008A021.
- December 18, 2013 Letter to M. Olson, Nuclear Information and Resource Service, Southeast, from A. Macfarlane, Chairman, NRC, regarding Public Comment on the GEIS on Waste Confidence, NUREG 2157, and proposed Waste Confidence Rule, 10CFR51. Accession No. ML13282A228.
- December 18, 2013 Summary of November 18 Public Meeting in Carlsbad, California, to Receive Comments on the Waste Confidence Draft Generic Environmental Impact Statement and Proposed Rule. Accession No. ML13352A432.
- December 18, 2013 Summary of November 20 Public Meeting in San Luis Obispo, California, to Receive Comments on the Waste Confidence Draft Generic Environmental Impact Statement and Proposed Rule. Accession No. ML13352A447.
- December 18, 2013 Summary of December 2 Public Meeting in Perrysburg, Ohio, to Receive Comments on the Waste Confidence Draft Generic Environmental Impact Statement and Proposed Rule. Accession No. ML13352A453.

December 18, 2013 Summary of December 4 Public Meeting in Minnetonka, Minnesota, to Receive Comments on the Waste Confidence Draft Generic Environmental Impact Statement and Proposed Rule. Accession No. ML13352A486.

December 20, 2013 Summary of December 9 Public Teleconference to Receive Comments on the Waste Confidence Draft Generic Environmental Impact Statement and Proposed Rule. Accession No. ML13354C057.

January 8, 2014 Notice of Forthcoming Public Teleconference to Discuss Status of Waste Confidence Generic Environmental Impact Statement and Rulemaking (January 29, 2014). Accession No. ML14008A104.

January 8, 2014 E-mail from WCO Outreach@nrc.gov, Waste Confidence January 29th status teleconference meeting notice. Accession No. ML14141A180.

January 16, 2014 Notice of Forthcoming Public Teleconference to Discuss Status of Waste Confidence Generic Environmental Impact Statement and Rulemaking. (FSME-14-005). Accession No. ML14016A389.

January 23, 2014 NRC Revises Review Schedule for Waste Confidence Environmental Study and Final Rule. Press Release No. 14-003. Accession No. ML14023A710.

January 23, 2014 E-mail from WCO Outreach@nrc.gov, Waste Confidence schedule adjustment. Accession No. ML14141A181.

February 14, 2014 Summary of January 29 Public Teleconference to Discuss Status of Waste Confidence Generic Environmental Impact Statement and Rulemaking. Accession No. ML14045A242.

February 18, 2014 Letter to B. Gibson, Board of Supervisors, San Luis Obispo County, from A. Vietti-Cook, Secretary of the Commission, NRC, regarding letter to Chairman Allison M. Macfarlane, dated December 17, 2013. Accession No. ML14050A092.

March 7, 2014 E-mail from WCO Outreach@nrc.gov, Waste Confidence Public Commission Meeting—March 21, 2014, at 1:00p EDT. Accession No. ML14141A159.

Appendix C

March 13, 2014	Notification of the NRC Staff's Commission Paper SECY-14-0025 on Waste Confidence and Upcoming Commission Meeting (FSME-14-025). Accession No. ML14071A441.
March 19, 2014	E-mail from WCO outreach@nrc.gov, How to access this Friday's Commission meeting on Waste Confidence. Accession No. ML14141A160.
March 26, 2014	E-mail from WCO outreach@Nrc.gov, Waste Confidence Commission meeting transcript, slides, and archived webcast. Accession No. ML14141A161.
April 24, 2014	Letter to A. Imboden, NRC, from the States of Vermont and Connecticut, and the Commonwealth of Massachusetts, Need for a supplemental waste confidence DGEIS (Docket NRC-2012-0246). Accession No. ML14118A077.

References

10 CFR Part 71. *Code of Federal Regulations*, Title 10, *Energy*, Part 71, "Packaging and Transportation of Radioactive Material." Washington, D.C.

10 CFR Part 73. *Code of Federal Regulations*, Title 10, *Energy*, Part 73, "Physical Protection of Plants and Materials." Washington, D.C.

Appendix D

Draft GEIS and Proposed Rule Comment Summaries and Responses

Appendix D

Draft GEIS and Proposed Rule Comment Summaries and Responses

See NUREG-2157, Volume 2 for Appendix D: Draft GEIS and Proposed Rule Comment Summaries and Responses

Appendix E

Analysis of Spent Fuel Pool Leaks

Appendix E

Analysis of Spent Fuel Pool Leaks

This appendix describes the environmental impacts of spent fuel pool leaks during the short-term storage timeframe.¹ For the analysis presented in this *Generic Environmental Impact Statement for Continued Storage of Spent Nuclear Fuel* (GEIS), the U.S. Nuclear Regulatory Commission (NRC) assumes that spent nuclear fuel (spent fuel) is removed from the pool within 60 years of the end of the reactor's licensed life for operation. Once removed from the spent fuel pool, the spent fuel will be transferred to dry casks for storage in an independent spent fuel storage installation or shipment to a repository.

As described in Section E.2, this appendix evaluates the potential offsite (i.e., outside the owner-controlled area) environmental impacts of spent fuel pool leaks. The environmental consequences of accidents, (e.g., cask drops) and natural events (e.g., earthquakes) that damage the spent fuel pool structure and result in a catastrophic loss of water volume in the spent fuel pool are discussed in Section 4.18 and Appendix F.

Section E.1 provides a historical overview of information pertaining to spent fuel pool leaks, including information on spent fuel pool designs, operation, and the history of spent fuel pool leaks at commercial nuclear power plants. Section E.2 describes the potential offsite environmental impacts of spent fuel pool leaks to groundwater, surface water, soils, and public health. Section E.3 presents historical data on spent fuel pool leaks.

E.1 Background

As of May 2014, 100 commercial nuclear reactors are licensed to operate in the United States, and 5 additional units are under construction. These operating reactors are located at 62 sites in 30 states (Figure E-1). Of these 100 reactors, 65 are pressurized water reactors and 35 are boiling water reactors. Because some of these reactors share spent fuel pools, there are 55 pressurized water reactor and 35 boiling water reactor spent fuel pools. In addition to operating reactor spent fuel pools, there are six spent fuel pools (5 pressurized water reactor, 1 boiling water reactor) located at five decommissioning reactors sites.

¹ As discussed in Section 1.8, the NRC assumes that all spent fuel is removed from the pools and placed in dry-cask storage by the end of the short-term storage timeframe. This appendix, therefore, does not analyze the impacts of a spent fuel pool leak after the short-term storage timeframe because a spent fuel pool will not be used to store spent fuel after that time.

U.S. Operating Commercial Nuclear Power Reactors

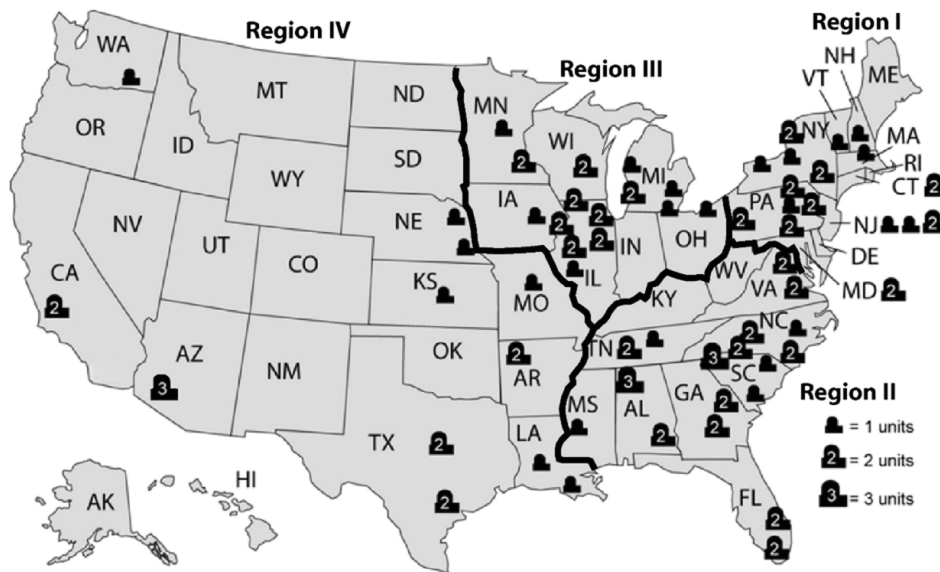
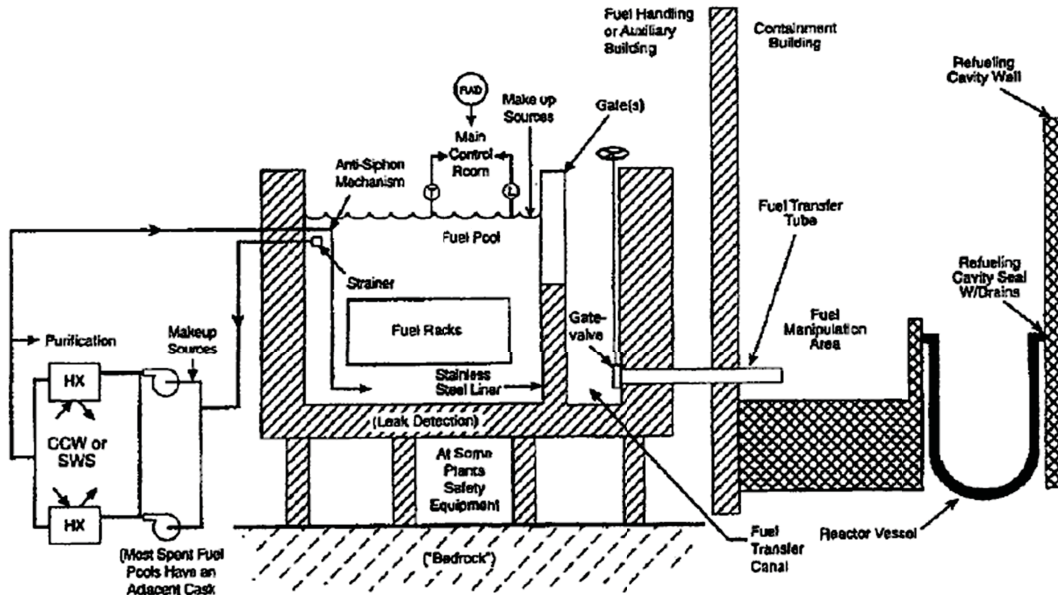

Figure E-1. Locations of U.S. Nuclear Power Plants (NRC 2013a)

E.1.1 Spent Fuel Pools

Figure E-2 shows diagrams of generic pressurized water reactor and boiling water reactor spent fuel pools. In general, spent fuel pools for boiling water reactor plants are elevated structures within the containment building and are filled with demineralized water. Spent fuel pools at pressurized water reactors are generally located in an auxiliary building adjacent to the reactor building and contain borated water (e.g., 2,200 to 2,400 ppm boron, pH ~4.8). A typical spent fuel pool for a pressurized water reactor is about 12 m [40 ft] deep and 12 m [40 ft] or more in each horizontal direction (Copinger et al. 2012). Water is maintained at a minimum depth of at least 6 m [20 ft] above the spent fuel bundles to ensure sufficient shielding of the spent fuel bundles. Water levels are maintained by periodically adding water to the pool to compensate for evaporation. Typically, the reinforced concrete walls are between 0.6 and 3 m [2 and 10 ft] thick and the inside surfaces are lined by welded stainless-steel plates to form a leak-tight barrier. These plates are generally about 6 to 13 mm [0.25 to 0.5 in.] thick and joined by full-penetration seam welds. The liner plates may also be plug welded between the seams to studs embedded in the concrete. In addition, all licensees actively monitor spent fuel pools for leakage, either directly through leak-detection systems or through various procedural controls. Leak-detection systems typically consist of several channels installed over the seams formed when spent fuel pool liner plates are welded together. These channels often can be monitored individually and are designed so leaked water empties into drains (i.e., “tell-tale” drains) where it can be monitored and returned to either sumps or other cleanup or collection systems (NRC 1997a).



(a)

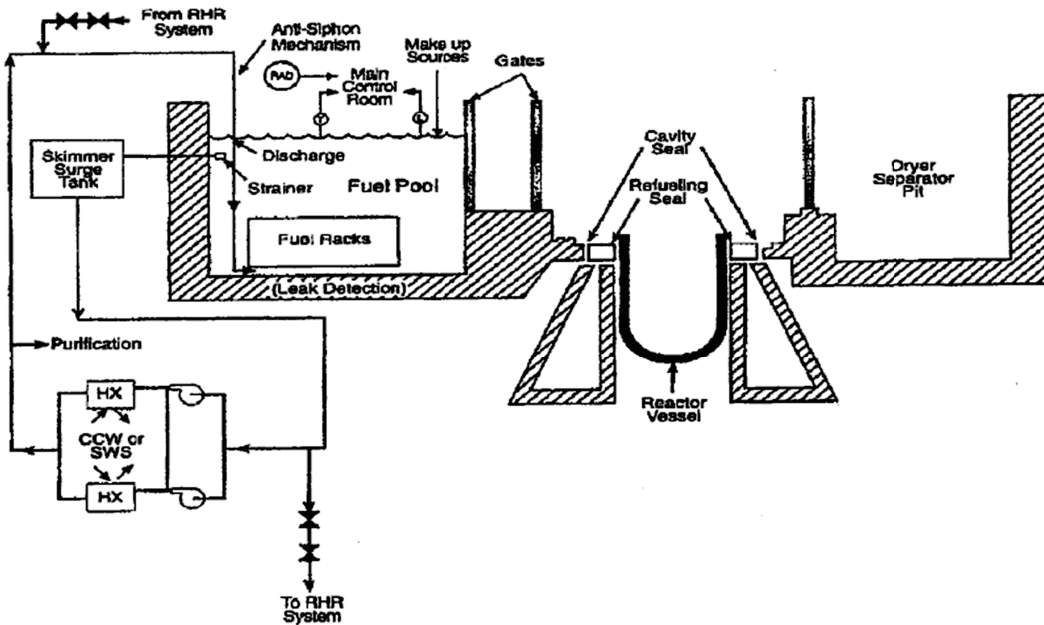

(b)

Figure E-2. Generic Layouts of Spent Fuel Pools and Transfer Systems for (a) Pressurized Water Reactors and (b) Boiling Water Reactors (NRC 1997a)

Appendix E

In addition, spent fuel pools are serviced by spent fuel pool cooling and purification systems. These systems provide cooling to the spent fuel in the pool, provide makeup water to the pool, maintain water chemistry, and remove fission products from the spent fuel pool water.

There is also one standalone spent fuel pool facility in the United States, the GE-Hitachi Nuclear Energy Americas, LLC, Morris wet storage facility (GEH Morris) in Morris, Illinois (DOE 2003). Though GEH Morris was originally designed as a commercial reprocessing facility, only the storage facility was completed and remains in operation. GEH Morris currently holds 3217 spent fuel assemblies from commercial nuclear power plants. These spent fuel assemblies are stored in two pools. As with spent fuel pools at nuclear power plants, the GEH Morris spent fuel pools are stainless-steel-lined reinforced concrete structures with leak-detection systems (GE 2004).

Spent Fuel Pool Maintenance

Even though the reactor is no longer operating during the short-term storage timeframe, a licensee is still bound by the terms and conditions of its operating license until the license is terminated. The safety of spent fuel storage is established for each facility through a safety analysis report prepared by the licensee to support its application for an operating license and reviewed by the NRC. Each safety analysis report includes a number of operational conditions and limitations important to safe spent fuel storage. These conditions and limitations are subject to regulations that restrict the changes that can be implemented without prior NRC approval. Among these regulations are requirements to implement managerial and administrative controls to ensure safe operation through implementation of the facility's quality assurance program (Title 10 of the *Code of Federal Regulations* [CFR] 50.54(a)(1)) and requirements for licensees to obtain a license amendment prior to implementing changes to the facility or facility procedures that do not meet certain criteria (10 CFR 50.59). In addition to these regulations, administrative technical specifications for nuclear power plants typically include a requirement to establish, implement, and maintain a broad range of procedures for safe operation of the facility. The design basis of the various facility structures, systems, and components and the licensee's NRC-approved quality assurance program, change control processes, and plant procedures ensure that the facility structures, systems, and components will operate and be maintained within established safety parameters to accomplish their functions during normal operating as well as accident conditions.

Licensees are required to monitor the performance and condition of structures, systems, and components important to safety (10 CFR 50.65). Monitoring provides reasonable assurance that the structures, systems, and components are capable of fulfilling their intended functions. Often referred to as the "Maintenance Rule," 10 CFR 50.65 further requires the licensee to take appropriate corrective action when the performance or condition of a structure, system, or component important to safety does not conform to established performance criteria. The main objective of the Maintenance Rule is to monitor the overall continuing effectiveness of

maintenance programs used by the licensees to ensure that safety-related (and certain nonsafety-related) structures, systems, and components are capable of performing their intended functions. All nuclear power plants have specific aging management programs to inspect, monitor, detect, and trend the aging of spent fuel structure concrete, liner plate and structural steel. The aging management programs also include acceptance criteria that can be used to evaluate the inspection results and determine if the spent fuel pool structure can perform its intended function or if corrective action is needed. The inspections are performed periodically at a frequency of 5 to 10 years.

For nuclear power plants that have undergone license renewal, the existing aging management program for the spent fuel pool concrete structure and liner plate is enhanced for the period of extended operation to monitor for leakage from the spent fuel pool. The enhancement requires monitoring to ensure that leak-chase channels embedded in the concrete as a part of the liner plate are open, unclogged, and allow free flow of water from the spent fuel pool liner plate. This leaked water is then collected, analyzed, treated, and disposed of properly. This approach helps ensure that the water from the spent fuel pool does not leak to the environment through cracks in the concrete. These inspections and monitoring activities help ensure that issues associated with aging of spent fuel pools will be identified and addressed in a timely manner, decreasing the likelihood that a spent fuel pool would develop a long-term, undetected leak due to aging-related degradation mechanisms. After shutdown, licensees may modify the aging management programs implemented as part of license renewal, through the appropriate regulatory mechanism (e.g., a license amendment request) or in accordance with the NRC's requirements at 10 CFR 50.59(c)(1). However, as discussed above, licensees are still bound by the requirements at 10 CFR 50.65 to maintain structures, systems, and components related to the spent fuel pool.

E.1.2 Groundwater Monitoring and Licensee Response to Leaks at Nuclear Power Plants

This section describes the NRC's requirements for identifying subsurface contamination and the nuclear industry's implementation of groundwater monitoring at nuclear power plant sites.

On June 17, 2011, the NRC issued its Decommissioning Planning Rule (76 FR 35512). The purpose of this rule, which amended regulations at 10 CFR Parts 20, 30, 40, 50, 70, and 72, is to "improve decommissioning planning and thereby reduce the likelihood that facilities under the NRC's jurisdiction will become legacy sites" (76 FR 35512). A legacy site is one with complex issues that is in a decommissioning status and whose owner cannot complete the decommissioning work for technical or financial reasons (76 FR 35512). The Decommissioning Planning Rule, through amended regulations at 10 CFR 20.1406 and 20.1501, requires licensees of operating facilities to "minimize the introduction of significant residual radioactivity into the site, including the subsurface, and to perform radiological surveys to identify the extent of significant residual radioactivity at their sites, including the subsurface" (NRC 2012). The

Appendix E

NRC has found that, in general, groundwater monitoring conducted in accordance with the Groundwater Protection Initiative developed by the Nuclear Energy Institute, a nuclear industry consortium, is adequate to comply with these regulations (NRC 2012). While licensees are not required to implement groundwater monitoring in accordance with the Groundwater Protection Initiative, they must still demonstrate compliance with the regulations at 10 CFR 20.1501 to perform subsurface surveys to identify contamination. For new nuclear power plants, licensees are subject to the additional requirements of 10 CFR 20.1406(a)-(b), of which “monitoring and routine surveillance programs are an important part of minimizing potential contamination” (NRC 2008).

The Nuclear Energy Institute developed its Groundwater Protection Initiative in 2006 in response to leaks containing radioactive material at several plants. The Initiative is described in NEI 07-07, *Industry Ground Water Protection Initiative – Final Guidance Document* (NEI 2007). All operating and decommissioning power reactor licensees have committed to follow the Initiative, which identifies actions to improve licensee response to inadvertent releases, including releases from spent fuel pools that may result in low, but detectable, levels of plant-related radioactive materials in subsurface soils and water. The Initiative identifies the actions licensees are expected to take, including the development of written groundwater protection programs, improved stakeholder communications, and program oversight. An important objective of the Initiative is to detect leaks well before radionuclide concentrations approach regulatory limits (e.g., the NRC’s 10 CFR Part 20 dose limits) for radioactive releases (NEI 2007). The Initiative also addresses detection and remediation of leaks. The Electric Power Research Institute, another industry organization, has published guidance to licensees on the design and implementation of a groundwater-monitoring program (EPRI 2008).

As part of these efforts, the nuclear power industry has committed to improving communication with external stakeholders, including members of the public as well as local, State, and Federal government officials. This includes: (i) periodic briefings on their site-specific groundwater protection programs; (ii) prompt notice to the cognizable authorities whenever significant onsite spills or leaks into groundwater occur or onsite or offsite monitoring results exceed monitoring standards; (iii) a written 30-day report to the NRC for any monitoring result for onsite groundwater that is, or may be used as, a source of drinking water that exceeds monitoring criteria; and (iv) an annual radiological environmental operating report or the annual radioactive effluent release report that documents onsite groundwater sample results and a description of any significant onsite leaks or spills into groundwater (NEI 2007).

Licensees might perform additional site-specific monitoring and reporting, based on State or local requirements, or agreements between the licensee and other interested parties. For example, as part of its settlement of spent fuel pool issues raised by parties to the Indian Point Units 2 and 3 relicensing proceeding, the licensee committed to publish the results of

groundwater monitoring at Indian Point on a quarterly basis to a publicly available website and to conduct additional fish sampling in accordance with its monitoring plan (Entergy 2012).

In April 2011, the NRC evaluated industry performance in *Summary of Results from Completion of NRC's Temporary Instruction on Groundwater Protection, TI-2515/173 Industry Groundwater Protection Initiative* (NRC 2011a). This report was based on inspections conducted between August 2008 and August 2010 at all nuclear power plant sites. The report found that groundwater-monitoring programs had been implemented at virtually all nuclear power plant sites, and that licensees achieved an aggregate 95 percent completion of the NEI 07-07 Hydrology and Geology, and Site Assessment objectives. For the onsite groundwater-monitoring objective, the completion rate was 92 percent (NRC 2011a). Based on a subsequent one-time inspection of licensees from the April 2011 report with five or more incomplete program elements, the NRC found that all elements of the Groundwater Protection Initiative had been implemented at all but three sites. For the three remaining sites, the remaining program elements had been added to the licensees' corrective action program (NRC 2014). The NRC continues to monitor the implementation and maintenance of licensees' groundwater-monitoring programs through routine inspections performed at all nuclear power plant sites.

Licensee responses to leaks are dictated by the requirements of various NRC regulations. If a spent fuel pool leaks and has the potential to result in onsite or offsite contamination, a licensee would be required by the NRC's regulations at 10 CFR 20.1501(a)(2) to perform surveys that are reasonable under the circumstances to evaluate the magnitude, extent, and potential radiological hazard of contamination. Based on the circumstances of the leak, a licensee may need to adjust its monitoring program (e.g., add more monitoring wells) to adequately characterize the extent of the contamination (NRC 2009). As required by 10 CFR 20.1501(b), licensees must document the location and amount of residual subsurface radioactivity in their decommissioning records. Further, as described earlier in this section, licensees have committed to providing a description of any significant onsite leaks or spills to groundwater in their annual radiological environmental operating reports or the annual radioactive effluent release reports required by 10 CFR 50.36a. For leaks to groundwater, Regulatory Guide (RG) 1.21, *Measuring, Evaluating, and Reporting Radioactive Material in Liquid and Gaseous Effluents and Solid Waste*, states that licensees should develop a site conceptual model, using standards such as American National Standards Institute/American Nuclear Society report 2.17-2010, *Evaluation of Subsurface Radionuclide Transport at Commercial Nuclear Power Plants* (ANSI/ANS 2010) to characterize, model, and monitor groundwater flow and radionuclide transport (NRC 2009). This conceptual and subsequent numerical model would be used as the basis for estimating the dispersion of radionuclide releases to groundwater. The monitoring program would confirm whether remediation programs are effective in precluding offsite impacts to groundwater resources.

E.1.3 Remediation Techniques

Various technologies are currently available to remediate the contaminated groundwater. Licensees decide whether and how to remediate a radioactive release to groundwater based on a variety of circumstances, including the source and magnitude of the contamination events; the local and regional groundwater systems (as reflected in the site conceptual model); the NRC's regulatory requirements (e.g., the radiological criteria for license termination in 10 CFR Part 20, Subpart E); and other Federal, State, and local requirements (e.g., U.S. Environmental Protection Agency [EPA] drinking-water standards).

As described in Ferry et al. (1999) groundwater contamination can be limited and mitigated through hydraulic isolation and capture, using groundwater extraction methods such as low-discharge pumping wells and interceptor trenches or a funnel and gate system for near-surface plumes. The extracted groundwater can be treated to remove highly absorptive radionuclides (e.g., strontium-90 and cesium-137) using appropriate separation technologies (e.g., ion-exchange systems). However, tritium cannot be absorbed in those systems.

Various separation technologies can be applied to remove contaminants from the extracted groundwater. For radioisotopes of elements such as barium, cesium, cobalt, iodide, manganese, plutonium, and strontium, various treatment technologies are commonly used in the chemical- and wastewater-treatment industries. Most of these technologies can be broadly classified into two groups, depending on the reaction mechanism involved (i.e., precipitation or sorption [including ion exchange]) (IAEA 1999).

Using remediation techniques to reduce tritium concentrations to levels below concentrations exceeding EPA drinking-water standards is more difficult than for other groundwater contaminants because tritium cannot be chemically absorbed. In general, the method used to remediate tritium is monitored natural attenuation with selective groundwater extraction for high-concentration areas. Monitored natural attenuation is a proven approach for addressing radiological contamination that has been accepted by the EPA (1999) and many State environmental regulatory agencies, such as the New York Department of Environmental Conservation (NYSDEC 2010). Nevertheless, treatment technologies that have potential application for reducing very high tritium levels in groundwater include water distillation, combined electrolysis and catalytic exchange, bithermal hydrogen-water process, girdler sulfide process, palladium membrane reactor, and the GE-Hitachi Nuclear Energy integrated systems (Geniesse and Stegen 2009).

E.2 Environmental Impacts of Spent Fuel Pool Leaks

This section addresses the environmental impacts of spent fuel pool leaks that might occur during the short-term storage timeframe. The NRC's Decommissioning Planning Rule,

discussed in Section E.1.2, requires licensees to identify the extent of significant residual radioactivity at their sites, including the subsurface (NRC 2012). Any significant radioactivity identified by licensees must be addressed during the decommissioning process to meet the license-termination requirements of 10 CFR Part 20, Subpart E. Consequently, the impacts from spent fuel pool leaks that result in contamination that remains onsite are addressed as part of the decommissioning and license-termination processes and are outside the scope of this GEIS. The environmental impacts resulting from both normal operations and accidents during decommissioning activities and all onsite or offsite residual radioactive material that may remain after license termination are addressed in *Generic Environmental Impact Statement on Decommissioning of Nuclear Facilities* (NRC 2002) and *Generic Environmental Impact Statement in Support of Rulemaking on Radiological Criteria for License Termination of NRC-Licensed Nuclear Facilities* (NRC 1997b), respectively.

E.2.1 Factors that Influence the Impacts of Spent Fuel Pool Leaks

A combination of factors minimizes the likelihood that a spent fuel pool leak occurring during the short-term storage timeframe will result in significant offsite environmental impacts. The combination of spent fuel pool design and maintenance; operational practices (e.g., spent fuel pool leakage monitoring and groundwater monitoring), site hydrogeological characteristics; and radionuclide-transport properties together make the likelihood very low that an undetected leak from the spent fuel pool will migrate offsite. These factors, plus NRC oversight and regulatory controls, will ensure that licensees identify and diminish potential consequences should a leak that results in an offsite release occur.

E.2.1.1 Spent Fuel Pool Design, Operation and, Monitoring

As noted below in Section E.3, spent fuel pool leaks have been documented at 13 nuclear power plant sites, and at two additional sites where the spent fuel pool was identified as a potential source of onsite contamination. Spent fuel pool leaks, while unpredictable, seldom occur. Stringent design features and operational controls minimize these occurrences. As discussed, all operating spent fuel pools are lined with stainless-steel liners that form a leak-tight barrier between the water in the pool and the concrete walls of the pool. In addition, all licensees actively monitor for leaks from spent fuel pools and will continue to do so throughout the short-term storage timeframe. In most cases, the combination of the spent fuel pool liner and leakage monitoring prevent spent fuel pool water from leaking undetected into the environment. Further, as described in Section E.1.1, the licensee is required to continuously ensure the integrity of the spent fuel pool liner and structure by maintaining a low-corrosive environment in the spent fuel pool water through proper water chemistry control.

Nonetheless, relatively small cracks can occur in the stainless-steel liner due to intergranular stress-corrosion cracking and crevice corrosion of the stainless-steel liner, seam or plug weld defects, or damage to the liner, resulting in leakage from the spent fuel pool (Copingier et al.

Appendix E

2012). For spent fuel pools with leakage-collection systems installed, these systems could become clogged or obstructed, which could cause the water to back up in the space between the liner and concrete. Spent fuel pool water that bypasses the collection system can migrate through construction joints and cracks in the concrete due to shrinkage, creep, or alkali silica reaction, resulting in release of contaminated water outside the pool. Whether resulting from leakage through the liner or clogging in the leakage-collection system, spent fuel pool leaks are uncommon and unpredictable. However, knowledge and techniques gained from earlier industry and NRC studies of spent fuel pool leaks have resulted in heightened awareness of leaks and earlier detection and mitigation.

Significant short-term water loss from a spent fuel pool is likely to be identified by licensee monitoring of spent fuel pool water levels. Further, because of NRC requirements to identify and minimize contamination (see Section E.1.2), licensees would likely identify and mitigate, if necessary, the impacts from any significant short-term water loss before noticeable offsite environmental impacts would occur (e.g., the releases at Hatch and Turkey Point which resulted in no noticeable offsite environmental impacts and are described in Section E.3). As a result, the NRC's analysis in this GEIS considers a long-term, low-volume undetected leak from a spent fuel pool as the most probable scenario in which spent fuel pool leakage would lead to an offsite environmental impact. To go undetected, the leak rate would have to be sufficiently low as to not exceed the fluctuations in water level of a spent fuel pool lost to evaporation. This is so because the spent fuel pool water level is constantly measured by instrumentation and routinely monitored by licensees. Also, licensees must perform routine inspections of leak-detection systems and physically inspect the spent fuel pool area for leakage.

Based on operational experience, the model leak used for analysis here is assumed to correspond to a leak rate of approximately 380 L/d [100 gpd] (NRC 2004). In analyzing the impacts of a spent fuel pool leak, the NRC assumed a leak rate similar to the rate of water lost due to evaporation, which would effectively double the makeup rate to the spent fuel pool. A leak of this magnitude would likely be identified in an expeditious manner because of licensee monitoring and surveillance.

In addition to spent fuel pool design and operational controls, as described in Section E.1.2, nuclear power plant licensees have implemented onsite groundwater-monitoring programs that satisfy the subsurface survey requirements of 10 CFR 20.1501. Onsite groundwater monitoring makes it unlikely that leakage from the spent fuel pool would remain undetected long enough for any contamination to migrate offsite. In addition, a groundwater-monitoring program based on a site characterization that conforms to standards (e.g., ANSI/ANS 2.17–2010) and a configuration of monitoring wells that takes into account the most likely leakage pathway (i.e., the spent fuel pool) would further reduce the likelihood that a leak would remain undetected long enough for contamination to migrate offsite.

E.2.1.2 Radionuclides in Spent Fuel Pools and Radionuclide Transport

Impacts from spent fuel pool leakage occur from radionuclide contaminants present in spent fuel pool water. The sources of radionuclide contaminants in spent fuel pool water are activation products and fission products. Activation products are elements formed from the neutron bombardment of a stable element and fission products are elements formed as a byproduct of a nuclear reaction and radioactive decay of other fission products. The sources of activation products are corrosion and wear deposits (including corrosion films on the fuel bundle surfaces). Fission products come from bundles with rods that failed in-reactor or from intact bundles that adsorbed circulating fission products (Johnson 1977).

Table E-1 lists radionuclides of concern expected to be present in the spent fuel pool water. The initial concentration column represents the concentration of radionuclides assumed to be present at the start of the short-term storage timeframe. The final concentration column represents those radionuclides at the end of the short-term storage timeframe, assuming only radioactive decay. Actual concentrations would vary based on the efficiency of the spent fuel pool purification system and the integrity of the spent fuel assemblies stored in the pool. Because of radioactive decay and the spent fuel pool purification system, spent fuel pool leaks that occur later in the short-term storage timeframe will likely have less impact on onsite soil and groundwater quality due to the lower concentration of radionuclides present in the leaked spent fuel pool water.

Table E-1. Spent Fuel Pool Radionuclides of Concern

Nuclide	Half-Life ^(a)	Initial Concentration ($\mu\text{Ci/mL}$) ^(b)	Final Concentration ($\mu\text{Ci/mL}$)
Co-58	72 days	3.5×10^{-4}	–
Co-60	5.3 years	8.0×10^{-4}	3.1×10^{-7}
Cs-134	2.1 years	8.6×10^{-4}	–
Cs-137	30 years	1.3×10^{-3}	3.3×10^{-4}
H-3	12.3 years	2.9×10^{-2}	1.0×10^{-3}
Sr-90	28.8 years	5.9×10^{-6}	1.4×10^{-6}

(a) Johnson (1977).
(b) NRC (2006a).

As discussed in the preceding section, spent fuel pool water with radioactive contaminants could leak through small, intergranular stress-corrosion or crevice-corrosion cracks in the stainless-steel liner into the space between the liner and the concrete. Because concrete has a very low permeability, it serves as an additional barrier between leaked spent fuel pool water and the environment. However, contaminated water could migrate to the environment through construction joints and cracks in the concrete if the water backs up in the space between the

Appendix E

liner and concrete and a sufficient hydraulic head is developed. As radionuclides migrate through the concrete structure, their concentrations in the leaked water and the volume released to the environment could be reduced by sorption onto the concrete material. Sorption, a process by which a substance in solution attaches onto a solid material, can retard the movement of radionuclides and thus reduce radionuclide concentrations in the leaked water.

Spent fuel pool water will likely leave the concrete structure at or near the ground surface and above the local unconfined water table. The initial migration of radionuclides from the spent fuel pool leak is usually vertically downward through the vadose zone (i.e., the surrounding and underlying unsaturated soil, backfill, or other near-surface, disturbed materials). However, the direction, rate, and volume of the leaked spent fuel pool water migration in the vadose zone is influenced by the zone's ambient water content, the moisture and pressure gradients within the material, and the associated volume of the liquid released that may cause local saturation (or perching of the released fluid) due to the material's inability to transmit water at the rate released (i.e., insufficient permeability).

If a sufficient leak volume is released or the unsaturated material underlying the pool has hydrologic conditions to transmit the leaked water, the soil "wetting event" associated with the spent fuel pool leak can cause vertical radionuclide migration to reach an underlying shallow water table or unconfined aquifer (i.e., a saturated hydrogeological unit) and thus contaminate the aquifer. The rate of water movement would depend on the existing water content of the porous media and the permeability (an intrinsic property of the porous media related to pore sizes). For low water contents, the rate of water movement downward would be slow. Consequently, it is possible that the water would initially be contained within the site area, but if the leak continues to be undetected, it will flow downwards in the direction of the aquifer. Once in the aquifer, the travel time to the environment outside the controlled boundary would depend upon the hydraulic gradient, the hydraulic properties of the aquifer, and the distance to the site boundary.

Various hydrologic and chemical processes could reduce the environmental impacts of radionuclides associated with leaked spent fuel pool water. As the contaminant plume evolves, the radionuclide concentrations may continue to decrease due to mixing, dilution, and radioactive decay. Different radioisotopes decay at different rates depending on their half-lives (see Table E-1). In addition, adsorption of radionuclides onto the aquifer matrix material may significantly delay the transport of radionuclides in the subsurface environment and keep radionuclide concentrations at low levels in groundwater. Further, adsorption may retard the movement of radionuclides because radionuclide mass is adsorbed on solid surfaces and becomes unavailable for transport by water. Although desorption of radionuclides from the aquifer matrix material back into the groundwater may eventually occur, concentrations will be much less than if no sorption occurred. Different radionuclides have different degrees of adsorptive interaction with geologic media due to the geologic materials and water chemistry. Some radionuclides (e.g., tritium) do not adsorb onto soil and bedrock and, therefore, move

generally at the same rate and direction as groundwater. Other radionuclides (e.g., strontium-90 and cesium-137) strongly adsorb onto geologic media and, thus, move much slower than the groundwater velocity and at reduced concentrations compared to the source of a leak. The degree of radionuclide adsorption and retardation depends on the properties of the geologic media (e.g., mineralogy, reactive surface area, and presence of organic matter) and groundwater chemistry (e.g., pH, oxidation-reduction potential, and complexing ion concentration).

E.2.1.3 Influence of Site Hydrological Conditions

Although it is unlikely that a leak from a spent fuel pool of sufficient magnitude and duration would go undetected long enough to result in offsite consequences, several factors mitigate any potential impacts should a leak occur. In particular, characteristics of groundwater flow and transport of radionuclides in groundwater would limit the amount of radioactivity that would travel offsite and reduce its concentration. A review of Final Safety Analysis Reports for existing and proposed nuclear power plants, licensee Radioactive Effluent and Environmental Reports, and other relevant reports indicates that nuclear power plants have certain common hydrologic characteristics such as being located near large bodies of water and being sited in areas where the presence of a vadose zone would tend to reduce the amount of radioactive material leaving the site and lessen the concentration. Because of the siting criteria of 10 CFR Part 100 spent fuel pools are often located, and will continue to be located, in areas with certain similar hydrologic characteristics.

By their nature, nuclear power plants require large volumes of water to provide cooling to plant systems. As a result, nuclear power plants, which include spent fuel pools, are typically located adjacent to, or near, large surface waterbodies (e.g., rivers, lakes, and oceans). Regional groundwater flow in the vicinity of most spent fuel pools, particularly shallow water table or unconfined aquifer flow, is toward these large surface waterbodies. Localized water table flow around spent fuel pools can be influenced by a variety of physical features and hydrological conditions. Subsurface features (e.g., basements) or surface features (e.g., buildings and paved areas) can result in localized disturbances to shallow groundwater flow directions and velocities. In addition, short-term (transient) factors (e.g., droughts, floods, and daily tidal influences) can induce a temporary change in shallow groundwater flow directions and rates. Nevertheless, despite these localized or short-term effects, the NRC's assessment of hydrologic conditions at existing nuclear power plant sites indicates that the water table aquifers at these sites typically have a predominantly horizontal flow component with ultimate discharge into an adjacent or nearby large waterbody.

Because most nuclear power plants are located at sites where the shallow unconfined groundwater at the site flows into the nearby surface waterbody, leaked water from the spent fuel pool at these sites would travel toward, and ultimately discharge into, the nearby surface waterbody. However, this travel time is often significant because the typical spent fuel pool

Appendix E

location adjacent to or in the vicinity of a large surface waterbody coincides with a relatively flat (i.e., small) hydraulic gradient in the shallow water table. Significant radiological decay of spent fuel pool contaminants occurs over the long travel times produced from a flat hydraulic gradient, resulting in reduced concentrations in the shallow water table.

Given the typical location of nuclear power plants near large surface waterbodies, the siting of reactors typically in areas of lower population density, and the typically large size of the licensee-controlled area surrounding the spent fuel pool and entire facility, it is unlikely that groundwater users will be located between the spent fuel pool and the nearest receiving surface waterbody. Put differently, it is unlikely that groundwater users will draw groundwater downgradient of the spent fuel pool, but upgradient of the surface waterbody. As a result, it is unlikely that local groundwater users would be situated in the downgradient path of a spent fuel pool related groundwater contaminant plume. The same site factors likewise make it unlikely that local groundwater pumping will have a significant influence on shallow groundwater flow conditions near the spent fuel pools (i.e., capture the spent fuel pool related plume due to pumping). In sum, for nuclear power plant sites with typical hydrological conditions, it is unlikely that any shallow water table aquifer users in the vicinity of the nuclear power plant would be affected by water leaked from a spent fuel pool. Rather, for spent fuel pools located at sites with these typical characteristics, any environmental impacts of spent fuel pool leakage would result from the discharge of contamination to the surface waterbody.

In many cases, groundwater users located outside the licensee-controlled area surrounding spent fuel pool locations use deeper confined aquifers (i.e., deeper aquifers separated from the shallow water table by one or more horizontally continuous low-permeability layers). Potable water supply wells are often intentionally placed in deeper aquifer units because of the sensitivity of shallow water table aquifers to surface sources of contamination (e.g., septic systems) and the impacts to shallow water supplies from climate variability. In addition, as with the shallow groundwater users discussed above, the typically large size of the licensee-controlled area surrounding the facility makes it unlikely that local groundwater pumping in the deeper confined aquifer would significantly influence shallow aquifer horizontal or vertical gradients at the spent fuel pool location. Moreover, it would be improbable for local deep aquifer potable wells to capture spent fuel pool affected groundwater from a shallow unconfined aquifer separated from the deeper system by a low-permeability confining layer.

Consequently, for nuclear power plant sites that exhibit the hydrologic conditions discussed above, the offsite environmental impacts would be minimal because groundwater contamination would likely either stay onsite or migrate toward a nearby surface waterbody. For contamination that remains onsite, licensees would be required to address any residual contamination as part of the license-termination process. Alternatively, if discharged to a large waterbody, as discussed in Section E.2.2.2, the quantities of radioactive material discharged to nearby surface

waters would be comparable to quantities associated with permitted, treated effluent discharges from operating nuclear power plants.

For spent fuel pools located at sites with hydrological conditions different from those described above, a leak from a spent fuel pool has the potential to affect nearby groundwater users. These potential impacts are discussed in Section E.2.2.1.

E.2.2 Analysis of the Impacts of Spent Fuel Pool Leaks

Systems or structures can experience undetected radioactive leaks over a prolonged period and those that are buried or in contact with soil (e.g., spent fuel pools) are particularly susceptible to undetected leakage (NRC 2006b). An important conclusion of the NRC Lessons Learned Task Force report (see Section E.3.1) is that the near-term health of the offsite public has not been affected by inadvertent liquid releases to the environment stemming from previous spent fuel pool leaks at U.S. nuclear facilities (NRC 2006b). As a result, environmental impacts from past leaks to groundwater have been minimal. Further, a senior management review of the NRC Groundwater Task Force (see Section E.3.1) concurred with the Groundwater Task Force's conclusion that the NRC is accomplishing its stated mission of protecting public health, safety, and the environment through its response to groundwater leaks and spills, consistent with its regulatory framework (NRC 2011b). This protection will continue through the short-term timeframe and will likely continue to be strengthened based on operating experience.

In the unlikely event of offsite migration, offsite physical resources that might be adversely affected by spent fuel pool leaks are groundwater, surface water, and soils. Potential public health impacts through these affected resources must also be considered. As described in Sections E.2.1.1–E.2.1.3, a variety of factors work together to make it unlikely that a leak from a spent fuel pool would result in offsite consequences. These include design and operational controls for the spent fuel pool, which should result in the detection and resolution of a leak before it develops sufficient volume to migrate offsite; radionuclide-transport properties, which would result in lower contaminant concentrations in the leak volume; and site hydrological characteristics, which lessen the likelihood that a leak would migrate offsite. As discussed in Section E.1.3, various remediation strategies can be employed in the event of a leak; however, the decision about whether and how to remediate a radioactive release to groundwater is based on a variety of circumstances including, but not limited to, the magnitude of the contamination, the NRC's regulatory requirements (e.g., the radiological criteria for license termination described in 10 CFR Part 20, Subpart E), and other Federal, State and local requirements (e.g., EPA drinking-water requirements).

E.2.2.1 Groundwater

Historically, radiological contamination from spent fuel pool leaks has remained onsite within each licensee's owner-controlled area or traveled to a nearby surface waterbody (see

Appendix E

Section E.3). Because these leaks have remained onsite or were discharged to large surface waterbodies, where significant dilution occurred, there have been no impacts to any offsite groundwater wells used as a potable resource. As described in Section E.2.1.3, this is mainly because the duration or volume of water leaked from the spent fuel pool was insufficient to result in elevated radionuclide concentrations away from the source or because the spent fuel pools are sited in areas where the hydrologic conditions either impede the flow of leaked water away from the source (e.g., flat hydraulic gradient) or direct flow to the nearby surface waterbody.

In the short-term timeframe, spent fuel pool design (stainless-steel liners and leakage-collection systems) and operational controls (monitoring and surveillance of spent fuel pool water levels) make it unlikely that a leak will remain undetected long enough such that contamination of the offsite environment would exceed any regulatory requirement (e.g., the NRC dose limit or EPA-mandated Maximum Contaminant Level). In addition, the onsite groundwater-monitoring programs implemented at all sites with spent fuel pools provide added protection with respect to identifying a spent fuel pool leak and, if necessary, isolating and remediating contaminated groundwater onsite. In addition, a variety of physical processes associated with radionuclide transport (see Section E.2.1.2) and hydrologic characteristics associated with typical nuclear power plant settings (see Section E.2.1.3) would mitigate the impacts from the offsite migration of future spent fuel pool leakage. These physical processes and hydrologic characteristics include radionuclide adsorption, dilution, and decay; delayed transport times due to the relatively flat hydraulic gradients in the shallow water tables; lengthy distance to local groundwater users; and the likelihood that local groundwater usage is in deeper confined aquifers. Further, current and future spent fuel pool sites are required to have routine environmental monitoring programs in place that should take samples at offsite groundwater sources (e.g., potable or irrigation) in areas where the hydraulic gradient or recharge properties are suitable for contamination (NRC 1991a,b). Finally, any detection of onsite contamination would likely result in additional monitoring, including additional sampling of any nearby private wells, as part of an expanded environmental monitoring program. With these measures and characteristics in place, it is improbable that offsite migration of spent fuel pool leaks will occur or go undetected.

However, it is possible that a nuclear power plant could be sited in a location in which the hydrological conditions would not preclude the offsite migration of contaminated groundwater in the event of a leak. In the unlikely event that a leak goes undetected at these sites and the resulting groundwater plume reaches the offsite environment, the leak could be of sufficient magnitude and duration that contamination of a groundwater source above a regulatory limit (e.g., a Maximum Contaminant Level for one or more radionuclide) could occur. The NRC acknowledges that, in that unlikely event, the radiological impacts on groundwater quality resulting from a spent fuel pool leak during the short-term timeframe could noticeably alter, but not destabilize a groundwater resource. However, because of the relatively small size of the

maximum leak rate likely to escape detection (see Section E.2.1.1), the impacts to groundwater would likely be highly localized and would not be expected to impact regional groundwater resources. If contamination from a spent fuel pool leak were to exceed a Maximum Contaminant Level for one or more radionuclides at a groundwater source that currently supplies water to public water supplies or that has the potential to supply a public water supply (including private wells), the EPA could take emergency action under the Safe Drinking Water Act (EPA 1991). Emergency actions include, but are not limited to, providing alternative water supplies, public notification of potentially affected users, and remediation of the contamination (EPA 1991).

The impacts of a spent fuel pool leak on offsite groundwater receptors depend on many factors, including the volume and rate of water released from the spent fuel pool, the radionuclide content and concentration and water chemistry of the spent fuel pool water, the direction of groundwater flow, the distance to an offsite groundwater receptor, the velocity or transport rates of radionuclides through the subsurface, and radioactive decay rates. However, as discussed previously, it is unlikely that a leak of sufficient quantity and duration could occur without detection, or that such a leak would not be impeded by physical processes and hydrologic characteristics typical at spent fuel pool locations. Therefore, based on the low probability of a leak with sufficient quantity and duration to reach offsite locations, the detection and monitoring mechanisms available to licensees and the NRC, physical processes associated with radionuclide transport, and the hydrologic characteristics at typical spent fuel pool sites, the NRC concludes that the radiological impacts to groundwater quality resulting from a spent fuel pool leak during short-term timeframe would be SMALL.

E.2.2.2 Surface Water

Spent fuel pool leaks can result in discharges of radionuclides to offsite surface waters. The concentrations of radionuclides in offsite surface waters will depend on the rate of release from the spent fuel pool, the direction and rate of groundwater flow, the distance to nearby offsite surface waters toward which groundwater flows, the velocity or transport rates of radionuclides through the subsurface, and radioactive decay rates. For a given rate of release, the concentrations of radionuclides and, consequently, the presence of radionuclides in surface water would be dependent on the duration of the spent fuel pool leak.

However, because surface water bodies in the vicinity of nuclear power plants (e.g., oceans, lakes, rivers) are large enough to meet reactor cooling requirements, a large volume of surface water is usually available, which would dilute any groundwater contaminants that flow into them. This dilution ensures that radionuclides present in groundwater with concentrations that might exceed the Maximum Contaminant Level for that radionuclide would be diluted well below EPA safe drinking-water limits.

Appendix E

To illustrate the low releases that would be associated with leaked spent fuel pool water, the NRC estimated the annual discharge rate associated with a leakage of 380 L/d [100 gpd] of radionuclides in spent fuel pool water at concentrations shown in Table E-1. The NRC's estimate takes into account groundwater transport considerations, including radioactive decay, and conservatively assumes steady-state conditions (i.e., constant flow over time). Based on these assumptions, the annual quantity of radionuclides, expressed as S that could reach a certain distance from the spent fuel pool can be expressed as a derivation of the decay equation:

$$S = S_o e^{-\lambda t}$$

where S = the annual discharge of radionuclides to nearby surface waters (Ci/yr)
 S_o = the annual leak of radionuclides from the spent fuel pool (Ci/yr)
 λ = $\ln(2)/t_{1/2}$ = the radioactive decay constant for the radionuclide (yr^{-1})
 t = the travel time for radionuclides to reach nearby surface waters (yr).

The variable t can be expressed as a ratio of distance traveled to a radionuclide's retard velocity:

$$t = \frac{xR}{u}$$

where x = the distance between the spent fuel pool leak and the nearby surface water (m)
 R = the retardation factor (dimensionless)
 u = the groundwater flow velocity (m/yr).

Therefore, the annual quantity of radionuclides that could reach a certain distance from the spent fuel pool can be expressed as

$$S = S_o e^{-\frac{\lambda x R}{u}}$$

The retardation factor, R , is expressed as (NRC 1983):

$$R = \left(1 + \frac{\rho_b}{n_e}\right) K_d$$

where ρ_b = the average soil density (g/cm^3)
 n_e = the effective porosity of the soil (dimensionless)
 K_d = the radionuclide distribution coefficient (L/kg).

The value of the radionuclide distribution coefficient (K_d), which describes the tendency of a radionuclide in groundwater to sorb to subsurface soil and rock, is higher for radionuclides that are strongly sorbed to soil and rock, and lower for radionuclides that tend to remain dissolved in

groundwater. Therefore, the higher the K_d value of a radionuclide or other contaminant, the slower it will migrate or be transported through soil and groundwater and into surface water. Using the leak rates calculated with the values from Table E-1, the expressions above, radioactive decay constants for each radionuclide, and reasonably conservative assumptions for the other parameters, it is possible to estimate the discharge of radionuclides from a spent fuel pool leak to nearby surface waters. A conservative assumption for groundwater flow velocity, u , is 30 cm/d (1 ft/d) or about 100 m/yr (330 ft/yr). Assuming the distance, x , from a spent fuel pool to nearby surface water is as little as 100 m (330 ft), the travel time for groundwater from the point of release at the spent fuel pool to the nearby surface water could be as little as about 1 year. A nominal bulk soil density, ρ_b , is about 1.6 g/cm³ and an average value of effective soil porosity, n_e , is 0.3 (Freeze and Cherry 1979). Values of K_d for isotopes of cesium are available in Table 4.6 of NUREG/CR-3332, *Radiological Assessment: A Textbook on Environmental Dose Analysis* (Till and Meyer 1983). A low value of K_d for cesium in soil is about 189 L/kg.

Using these conservative assumptions, radioactive cesium isotopes would not reach nearby surface water before either decaying in place a short distance from the spent fuel pool or being removed during decommissioning activities. Using published values of K_d for cobalt ($K_d = 60$) (Sheppard 1990) and cobalt isotope half-lives ($t_{1/2}$) from Table E-1, cobalt isotopes would remain near the leak source and decay or be removed during decommissioning activities well before reaching nearby surface waters. Strontium-90 has a sufficiently long half-life of 28.8 years, and a low enough K_d in some soils (e.g., 15 L/kg in sand)(Sheppard 1990) that it could reach nearby surface waters. Although tritium has a relatively short half-life (12.3 years), it moves at the same rate as water through soil and groundwater strata (i.e., effective $K_d = 0$).

Therefore, the only radionuclides that could be expected to reach nearby surface water through groundwater are tritium and strontium-90. The tritium leakage values calculated using the methodology described above are compared in Table E-2 below to the annual liquid effluent discharges in 2008 for boiling water reactors and pressurized water reactors (NRC 2010a). Strontium-90 leakage values are compared to detectable strontium-90 releases from boiling water reactors and pressurized water reactors from 2005 through 2009, which are taken from individual plant Radioactive Effluent and Environmental Reports on NRC's website (see <http://www.nrc.gov/reactors/operating/ops-experience/tritium/plant-info.html>).

As shown in Table E-2, even in the unlikely event that undetected spent fuel pool leakage flowed continuously (24 hours per day, 365 days per year) to local surface waters, the quantities of radioactive material discharged to nearby surface waters would be comparable to values associated with permitted, treated effluent discharges from operating nuclear power plants.

Based on these considerations, the NRC concludes that the impact of spent fuel pool leaks on surface water would be SMALL.

Appendix E

Table E-2. Comparison of Tritium and Strontium-90 Released From a Spent Fuel Pool Leak to Radionuclides Discharged During Normal Operations

Radionuclide	Spent Fuel Pool Leakage (Ci/yr)	Boiling Water Reactor Effluent Range (Ci/yr)	Pressurized Water Reactor Effluent Range (Ci/yr)
H-3	3.8	0.00113 to 127	159 to 1,660
Sr-90 ^(a)	8.3×10^{-5}	5.4×10^{-7} to 2.0×10^{-4}	7.5×10^{-7} to 1.6×10^{-3}

(a) For calendar years 2005 through 2009.

E.2.2.3 Soils

Spent fuel pool leaks could result in localized radiological contamination of offsite soils. The degree of offsite soil contamination would depend on the rate of release from the spent fuel pool, the direction of groundwater flow, the distance to offsite locations, the velocity or transport rates of radionuclides through soils, and radioactive decay rates. For a given rate of release, the soil radionuclide concentrations and mass of soil contaminated would be dependent on the duration of the spent fuel pool leak.

As stated above in Section E.2.2.1, contamination in groundwater is likely to be observed as part of a licensee's radiological environmental monitoring program prior to the contamination plume reaching the offsite environment, and corrective action would be taken consistent with Federal and State requirements. In addition, most radionuclides move at a much slower rate and are much more likely to be adsorbed to the concrete structures of the spent fuel building and the soil surrounding the leak location. As a result, most soil contamination from spent fuel pool leaks would be expected to remain onsite and, therefore, offsite soil contamination is unlikely to occur. Therefore, the NRC concludes that the environmental impact of spent fuel pool leaks to offsite soils would be SMALL.

E.2.2.4 Public Health

For the purposes of assessing radiological impacts, environmental impacts are considered to be SMALL if releases and doses do not exceed permissible levels set by the NRC and the EPA. Therefore, the impact to public health would be SMALL if the spent fuel pool leakage was detected and remediated before regulatory limits for drinking water (e.g., EPA Maximum Contaminant Level) or effluent discharges (NRC dose standards in 10 CFR Part 50, Appendix I) were exceeded. As described above, should a pool leak continue undetected for a long period, a highly localized exceedance of groundwater protection standards could occur. Public health concerns related to groundwater contamination would be limited to private wells nearest the site. Surface water and regional groundwater resources will not be significantly affected for the reasons discussed in Sections E.2.2.1 and E.2.2.2. In the event of uncontrolled and undetected discharges associated with long-term spent fuel pool leaks to nearby surface waters, the annual

discharge would be comparable to normal discharges associated with operating reactors, and would likely remain below the standards set by the NRC for normal operational effluents in 10 CFR Part 50, Appendix I. In the unlikely event that a pool leak remained undetected for a long period, public health regulatory limits (e.g., EPA drinking-water standards) could be exceeded, and, therefore, the NRC has determined that public health impacts could be noticeable, but not destabilizing in these circumstances. However, as discussed in Section E.2.2.1, it is unlikely that a leak of sufficient quantity and duration could occur without detection or that such a leak would not be impeded by the physical processes associated with radionuclide transport and hydrologic characteristics typical of spent fuel pool locations. Therefore, based on the low probability of a leak affecting offsite groundwater sources, the NRC concludes that impacts to public health resulting from a spent fuel pool leak during the short-term timeframe would be SMALL.

E.2.2.5 Summary

Table E-3 summarizes the NRC impact determinations for the resource areas discussed in Sections E.2.2.1 through E.2.2.4.

Table E-3. Summary of Environmental Impacts of Spent Fuel Pool Leakage

Resource Area	Impact Determination
Groundwater	SMALL
Surface Water	SMALL
Soils	SMALL
Public Health	SMALL

E.3 Historical Data on Spent Fuel Pool Leakage

Although the evaluation of spent fuel pool leaks in Section E.2 focuses on the potential impacts of leaks during short-term storage timeframe, it is helpful to review the historical occurrences of spent fuel pool leaks. A review of past spent fuel pool leaks helps to establish a representative baseline for the analysis of future impacts and provides context to those impacts. As presented in Table E-4, the NRC has identified seven sites where contamination from the spent fuel pool has migrated outside of the spent fuel pool building. Two of the sites identified (Hatch and Turkey Point) were associated with operational issues that resulted in short-term, high-volume releases of water from the spent fuel pool. In both of these cases, the release was immediately identified by the licensee and appropriate action was taken to minimize impacts on the environment. Five of the sites (Indian Point, Palo Verde, Salem, Seabrook, and Watts Bar) were associated with a spent fuel pool leak that went undetected for some period of time. In addition to these seven sites, two additional sites (San Onofre and Yankee Rowe) were identified in which the spent fuel pool was implicated as a potential source of onsite contamination. The NRC has also identified at least seven sites where leakage from the spent fuel pool was contained within the leakage-collection system, or within the spent fuel pool

Appendix E

building. Spent fuel pool leakage at boiling water reactor plants has been identified primarily through leak-detection systems. Spent fuel pool leakage at pressurized water reactor plants has been detected in the leak-chase system (channels installed behind spent fuel pool liner welds); as seepage associated with concrete cracks; by the presence of white deposits on structures (boric acid precipitate); by the presence of moisture in the seismic gap between the fuel-handling building and auxiliary building; and by the presence of abnormally high levels of tritium in groundwater (i.e., above normal background levels of approximately 200 pCi/L and by contamination of protective clothing) (Copinger et al. 2012).

At several of the sites listed in Table E-4, namely Indian Point (Units 1 and 2), Palo Verde (Unit 1), Salem (Units 1 and 2), Seabrook, and Watts Bar, spent fuel pool leakage has resulted in inadvertent liquid radioactive releases to the environment. Releases that were known to have occurred to the environment from spent fuel pool leakage prior to 2006 were examined by the NRC Liquid Radioactive Release Lessons Learned Task Force as part of its review of historical information on abnormal, unplanned, unmonitored releases of radioactive liquids into the environment from nuclear power plants (NRC 2006b). The NRC Groundwater Task Force (NRC 2010b) reviewed data on releases to groundwater that occurred subsequent to the publication of the Lessons Learned Task Force report. A more recent study identified other nuclear power facilities that have experienced spent fuel pool leakage, including Crystal River Unit 3, Davis-Besse Unit 1, Diablo Canyon Units 1 and 2, Duane Arnold, Hope Creek, and Kewaunee (Copinger et al. 2012). For those facilities, with the exception of Kewaunee, the leakage was contained within the spent fuel pool leakage-collection system. For Kewaunee, the leakage was contained in the waste drumming room adjacent to the spent fuel pool (Copinger et al. 2012).

Table E-5 lists the maximum contamination detected onsite and at offsite locations from the spent fuel pool leakage events. None of the spent fuel pool leakage events listed in Table E-5 are known to have resulted in contamination of drinking water.

NRC Groundwater Task Forces

In 2006, the NRC chartered an in-house Lessons Learned Task Force to conduct a systematic lessons-learned review of unplanned, unmonitored releases of radioactive liquids into the environment from nuclear plants, which included inadvertent releases from spent fuel pools as well as other plant systems. The Lessons Learned Task Force reviewed industry experience, associated public health impacts (if any) of the radioactive liquid releases into the environment, the NRC regulatory framework, related NRC inspection and enforcement programs, industry reporting requirements, past industry actions following significant inadvertent releases,

Table E-4. Occurrence of Spent Fuel Pool Leakage at U.S. Nuclear Power Plants

Site	Date(s) of Leak Discovery	Detection Method	Radioactive Liquid Released to Environment?	Radionuclides Detected
<i>Operational Releases</i>				
Hatch	December 1986	Operator observation	Yes	Tritium and mixed fission products
Turkey Point	August 1988	Operator observation	Yes	Tritium, cesium-137, and cobalt-60
<i>Confirmed Spent Fuel Pool Leaks</i>				
Indian Point (Units 1 and 2)	August 2005; Unit 1 leakage predates August 2005	Discovered during excavation	Yes	Tritium, nickel-63, cesium-137, strontium-90, and cobalt-60
Palo Verde (Unit 1)	July 2005	Routine surveillance	Yes	Tritium, cobalt-60, antimony-125, and cesium-137
Salem (Unit 1)	September 2002	Personnel monitoring	Yes	Tritium
Seabrook	June 1999	Environmental monitoring	Yes	Tritium
Watts Bar (Unit 1)	August 2002	Environmental monitoring	Yes	Tritium
Crystal River (Unit 3)	2009	Routine surveillance	No ^(a)	—
Davis-Besse	2000	Routine surveillance	No ^(a)	—
Diablo Canyon (Units 1 and 2)	2010	Routine surveillance	No ^(a)	—
Duane Arnold	1994	Routine surveillance	No ^(a)	—
Hope Creek	2009	Routine surveillance	No ^(a)	—
Kewaunee	2007	Routine surveillance	No ^(b)	—
Salem (Unit 2)	2010	Routine surveillance	No ^(a)	—
<i>Potential Spent Fuel Pool Leaks</i>				
San Onofre (Unit 1)	1986	^(c)	Yes	Tritium, cesium-137
Yankee Rowe	1979/1999	^(d)	Yes ^(d)	Tritium

Sources: SCE 1995; ANP 2003; FPL 2006; NRC 2006b; YAEC 2006; NRC 2010b; NRC 2010c; Copinger et al. 2012

(a) Leaked spent fuel pool water was contained within spent fuel pool leakage-collection system.

(b) White deposits, possibly boric acid, observed on the wall and ceiling of the waste drumming room adjacent to the spent fuel pool.

(c) Contaminated groundwater was discovered during the decommissioning of San Onofre Unit 1. The source of the contaminated water was not clearly identified, but was suspected to have originated from any of three sources, one of which was leakage from the spent fuel pool that occurred from 1986 to 1989 (NRC 2010c). Environmental monitoring performed by the licensee subsequent to the leak did not identify radionuclides in the environment attributable to San Onofre (SCE 1995).

(d) The licensee suspects that the spent fuel pool leaked periodically until the installation of a liner in 1979; however, the amount of leakage was not discernable based on water level changes and makeup rates (YAEC 2006). The licensee identified additional leakage thought to be attributable to the spent fuel pool in 1999. Based on its evaluation, the licensee estimated that the leak rate was approximately 10 gal/yr (38 L/yr)(ANP 2003). The most significant source of onsite groundwater contamination is suspected to have resulted from a leak in the ion-exchange pit that released approximately 2 million gallons (7.6 million liters) of contaminated water through a construction joint at the common wall between the spent fuel pool and ion-exchange pit (YAEC 2006).

Appendix E

international perspectives (principally from the Canadian experiences with tritium releases), and NRC communications with members of the public. In its final report (NRC 2006b), the Lessons Learned Task Force made 26 recommendations that generally addressed enhanced regulations or regulatory guidance for unplanned, unmonitored releases; additional reviews in the areas of decommissioning funding and license renewal; and enhanced public communications.

The most significant conclusion of the Lessons Learned Task Force was with respect to public health impacts. Although a number of industry events has caused radioactive liquid releases to the environment in an unplanned and unmonitored manner, based on the available data, the task force did not find any instance in which the radioactive liquid releases affected the health of the public (NRC 2006b).

Table E-5. Dose from Inadvertent Releases of Radioactive Liquids from Nuclear Power Plant Spent Fuel Pools

Site	Maximum Contamination (pCi/L) Detected Within the Site Boundary	Maximum Water Contamination (pCi/L) at Offsite Locations	Receptor and Pathways	Yearly Dose (mrem)
Hatch	^(a)	None detected at offsite water sources; long-term monitoring in place	NA	NA
Indian Point	200,000 for tritium 100 for nickel-63 50 for strontium-90	Approximation made in dose calculations	MEI ^(b)	0.0021 ^(c)
Salem	15,000,000 for tritium ^(d)	None detected	NA	NA
Seabrook	750,000 for tritium	Groundwater plume has not migrated offsite	NA	NA
Turkey Point	^(e)	None detected	NA	NA
Watts Bar	550,000 for tritium	Groundwater plume has not migrated offsite	NA	NA

Source: Entergy 2006; FPL 2006; NRC 2013b; NRC 2013c

(a) Approximately 124,000 gal of liquid containing 0.2 Ci of tritium and 0.373 Ci of mixed fission products were released to a swamp which is located in the owner-controlled area. No public dose is calculated for releases to owner-controlled area.

(b) MEI = Maximally exposed individual: A hypothetical individual who, because of proximity, activities, or living habits, could potentially receive the maximum possible dose of radiation or of a hazardous chemical from a given event or process.

(c) Total body dose was calculated based on the assumption that all onsite groundwater discharged directly to the Hudson River (Entergy 2006). The calculated dose represents 0.0021% of the NRC's radiation dose limit to individual members of the public, as defined in 10 CFR Part 20.

(d) Maximum tritium level in sample of groundwater near the seismic gap; extensive groundwater remediation program in place.

(e) Approximately 6 to 7 gal of liquid (23 to 26 L) containing 2.5×10^{-3} $\mu\text{Ci}/\text{cm}^3$ of cesium-137, 2.5×10^{-4} $\mu\text{Ci}/\text{cm}^3$ of tritium, and 2.2×10^{-2} $\mu\text{Ci}/\text{cm}^3$ of cobalt-60 were released to storm drains. Leakage discharged into the intake of the plant cooling canal, which is a large, closed loop onsite flow path (55 FR 38474).

NA = Not applicable because water contamination was not detected at offsite locations.

In 2010, following further inadvertent, abnormal releases of radionuclides to the environment from nuclear power plant operations, the NRC established a second task force, referred to as the NRC Groundwater Task Force. The Groundwater Task Force reevaluated the recommendations in the Lessons Learned Task Force final report; reviewed NRC staff actions to address the issue of leaks from buried piping at nuclear power plants; and reviewed the actions taken in response to more recent releases of tritium from systems other than those associated with spent fuel pools into groundwater at nuclear facilities. The scope of the Groundwater Task Force work included industry experience; health impacts; the regulatory framework; NRC inspections and analyses; enforcement and reporting aspects; industry actions; international perspectives; and communications with external stakeholders. After completing its review, the Groundwater Task Force determined that the NRC is accomplishing its stated mission of protecting public health, safety, and the environment through its response to groundwater leaks and spills.

E.4 References

10 CFR Part 20. *Code of Federal Regulations*, Title 10, *Energy*, Part 20, “Standards for Protection Against Radiation.” Washington, D.C.

10 CFR Part 50. *Code of Federal Regulations*, Title 10, *Energy*, Part 50, “Domestic Licensing of Production and Utilization Facilities.” Washington, D.C.

10 CFR Part 100. *Code of Federal Regulations*, Title 10, *Energy*, Part 100, “Reactor Site Criteria.” Washington, D.C.

55 FR 38474. September 18, 1990. “Waste Confidence Decision Review,” *Federal Register*, U.S. Nuclear Regulatory Commission, Washington, D.C.

76 FR 35512. June 17, 2011. “Decommissioning Planning,” *Federal Register*, U.S. Nuclear Regulatory Commission, Washington, D.C.

ANP (Framatome ANP). 2003. *Site Ground Water Data Collection for YNPS Decommissioning*. DESD-YR-02-001, Revision 1. Accession No. ML031470580.

ANSI/ANS (American National Standards Institute/American Nuclear Society). 2010. *Draft Evaluation of Subsurface Radionuclide Transport at Commercial Nuclear Power Plants*. ANSI/ANS-2.17-2010, La Grange Park, Illinois. Accession No. ML101310455.

Copinger, D.A., C.B. Oland, and D.J. Naus. 2012. *Summary of Aging Effects and Their Management in Reactor Spent Fuel Pools, Refueling Cavities, Tori, and Safety-Related Concrete Structures*. NUREG/CR-7111, Oak Ridge National Laboratory, Oak Ridge, Tennessee. Accession No. ML12047A184.

Appendix E

DOE (U.S. Department of Energy). 2003. *National Report Joint Convention on the Safety of Spent Fuel Management and on the Safety of Radioactive Waste Management*.

DOE/EM-0654, Washington, D.C. Available at

<http://energy.gov/sites/prod/files/1st%20US%20JC%20report.pdf>.

Entergy (Entergy Nuclear Operations, Inc.). 2006. *2005 Annual Radioactive Effluent Release Report*. Buchanan, New York. Accession No. ML061240373.

Entergy (Entergy Nuclear Operations, Inc.). 2012. *Joint Motion for Approval of Settlement Agreement and Dismissal of Consolidated Contention Riverkeeper EC-3 and Clearwater EC-1 (Spent Fuel Pool Leaks)*. Washington, D.C. Accession No. ML12286A178.

EPA (U.S. Environmental Protection Agency). 1991. *Final Guidance on Emergency Authority Under Section 1431 of the Safe Drinking Water Act*. WSG 68, Washington, D.C. Available at

http://www.epa.gov/safewater/wsg/wsg_68.pdf.

EPA (U.S. Environmental Protection Agency). 1999. *Use of Monitored Natural Attenuation at Superfund, RCRA Corrective Action, and Underground Storage Tank Sites*. U.S. Environmental Protection Agency, Office of Solid Waste and Emergency Response Directive 9200.4-17P, Washington, D.C. Available at <http://www.epa.gov/oust/directiv/d9200417.pdf>.

EPRI (Electric Power Research Institute). 2008. *Groundwater Protection Guidelines for Nuclear Power Plants*. 1016099, Palo Alto, California. Accession No. ML091170595.

Ferry, L., R. Ferry, W. Isherwood, R. Woodward, T. Carlsen, Z. Demir, R. Qadir, and M. Dresen. 1999. *Final Site-Wide Feasibility Study for Lawrence Livermore National Laboratory Site 300*. UCRL-AR-132609, Lawrence Livermore National Laboratory, Livermore, California. Available at <http://www-erd.llnl.gov/library/AR-132609.html>.

FPL (Florida Power & Light). 2006. *Groundwater Protection—Data Collection Questionnaire*. Juno Beach, Florida. Accession No. ML062280570.

Freeze, R.A. and J.A. Cherry. 1979. "Groundwater." Prentice-Hall, Inc., Englewood Cliffs, New Jersey.

GE (General Electric Company). 2004. *Morris Operation Consolidated Safety Analysis Report*. NEDO-21326D11, Morris, Illinois. Accession No. ML080220416.

Geniesse, D.J. and G.E. Stegen. 2009. *2009 Evaluation of Tritium Removal and Mitigation Technologies for Wastewater Treatment*. DOE/RL-2009-18, Richland, Washington. Available at <http://www.osti.gov/scitech/servlets/purl/948439>.

IAEA (International Atomic Energy Agency). 1999. *Technical Options for the Remediation of Contaminated Groundwater*. IAEA-TECDOC-1088, Vienna, Austria. Available at http://www-pub.iaea.org/MTCD/publications/PDF/te_1088_prn.pdf.

Johnson, A., Jr. 1977. *Behavior of Spent Nuclear Fuel in Water Pool Storage*. BNWL-2256, Battelle-Pacific Northwest Laboratories, Richland, Washington. Available at <http://www.osti.gov/scitech/servlets/purl/7284014>

NEI (Nuclear Energy Institute). 2007. *Industry Ground Water Protection Initiative—Final Guidance Document*. NEI 07-07, Washington, D.C. Accession No. ML072600295.

NRC (U.S. Nuclear Regulatory Commission). 1991a. *Offsite Dose Calculation Manual Guidance: Standard Radiological Effluent Controls for Pressurized Water Reactors*. Generic Letter 89-01, Supplement No. 1, NUREG-1301, Washington, D.C. Accession No. ML091050061.

NRC (U.S. Nuclear Regulatory Commission). 1991b. *Offsite Dose Calculation Manual Guidance: Standard Radiological Effluent Controls for Boiling Water Reactors*. NUREG-1302, Generic Letter 89-01, Supplement No. 1, Washington, D.C. Accession No. ML031290469.

NRC (U.S. Nuclear Regulatory Commission). 1997a. *Operating Experience Feedback Report: Assessment of Spent Fuel Cooling*. NUREG-1275, Volume 12, Washington, D.C. Accession No. ML010670175.

NRC (U.S. Nuclear Regulatory Commission). 1997b. *Generic Environmental Impact Statement in Support of Rulemaking on Radiological Criteria for License Termination of NRC-Licensed Nuclear Facilities*. NUREG-1496, Washington, D.C. Accession Nos. ML042310492, ML042320379, ML042330385.

NRC (U.S. Nuclear Regulatory Commission). 2002. *Final Generic Environmental Impact Statement on Decommissioning of Nuclear Facilities, Supplement 1 Regarding the Decommissioning of Nuclear Power Reactors, Final Report*. NUREG-0586, Volumes 1 and 2, Washington, D.C. Accession Nos. ML023470327, ML023500228.

NRC (U.S. Nuclear Regulatory Commission). 2004. *Spent Fuel Pool Leakage to Onsite Groundwater*. Information Notice 2004-05, Washington, D.C. Accession No. ML040580454.

NRC (U.S. Nuclear Regulatory Commission). 2006a. *Indian Point Nuclear Generating Unit 2 - NRC Special Inspection Report No. 05000247/2005011*. Washington D.C. Accession No. ML060750842.

Appendix E

NRC (U.S. Nuclear Regulatory Commission). 2006b. *Liquid Radioactive Release Lessons Learned Task Force Final Report*. Washington, D.C. Accession No. ML062650312.

NRC (U.S. Nuclear Regulatory Commission). 2008. *Minimization of Contamination and Radioactive Waste Generation: Life-Cycle Planning*. Regulatory Guide 4.21, Washington, D.C. Accession No. ML080500187.

NRC (U.S. Nuclear Regulatory Commission). 2009. *Measuring, Evaluating, and Reporting Radioactive Material in Liquid and Gaseous Effluents and Solid Waste*. Regulatory Guide 1.21, Revision 2, Washington, D.C. Accession No. ML091170109.

NRC (U.S. Nuclear Regulatory Commission). 2010a. *Radioactive Effluents from Nuclear Power Plants, Annual Report 2008*. Washington, D.C. Accession No. ML103620452.

NRC (U.S. Nuclear Regulatory Commission). 2010b. *Groundwater Task Force Final Report*. Washington, D.C. Accession No. ML101740509.

NRC (U.S. Nuclear Regulatory Commission). 2010c. *Response to Questions Concerning Spent Fuel Pool Leakage at the San Onofre Nuclear Generating Station, Unit 1*. Arlington, Texas. Accession No. ML101400386.

NRC (U.S. Nuclear Regulatory Commission). 2011a. Memorandum from R.L. Conaster to U.S. Shoop dated April 1, 2011, regarding "Summary of Results from Completion of NRC's Temporary Instruction on Groundwater Protection, TI-2515/173, "Industry Groundwater Protection Initiative." Washington, D.C. Accession No. ML11088A047.

NRC (U.S. Nuclear Regulatory Commission). 2011b. *Senior Management Review of Overall Regulatory Approach to Groundwater Protection*. SECY-11-0019, Washington, D.C. Accession No. ML12338A692.

NRC (U.S. Nuclear Regulatory Commission). 2012. *Decommissioning Planning During Operations*. Regulatory Guide 4.22, Washington, D.C. Accession No. ML12158A361.

NRC (U.S. Nuclear Regulatory Commission). 2013a. *2013-2014 Information Digest*. NUREG-1350, Volume 25, Washington, D.C. Accession No. ML13241A207.

NRC (U.S. Nuclear Regulatory Commission). 2013b. *Generic Environmental Impact Statement for License Renewal of Nuclear Plants*. NUREG-1437, Volume 1, Revision 1, Washington, D.C. Accession No. ML13107A023.

NRC (U.S. Nuclear Regulatory Commission). 2013c. *Final Environmental Statement: Related to the Operation of Watts Bar Nuclear Plant, Unit 2*. NUREG-0498, Supplement 2, Volume 1, Washington, D.C. Accession No. ML13144A092.

NRC (U.S. Nuclear Regulatory Commission). 2014. Memorandum from S.M. Gary to U.S. Shoop dated April 11, 2014, regarding "Roll-Up of Temporary Instruction (TI) 2515/185, "Follow-Up on the Industry's Ground Water Protection Initiative." Washington, D.C. Accession No. ML14086A644.

NYSDEC (New York State Department of Environmental Conservation). 2010. *Technical Guidance for Site Investigation and Remediation*. DER-10, Albany, New York. Available at: http://www.dec.ny.gov/docs/remediation_hudson_pdf/der10.pdf.

SCE (Southern California Edison Company). 1995. *SONGS Unit 1 Spent Fuel Pool Liner Plate Evaluation*. San Clemente, California. ADAMS Legacy Library Accession No. 9503200118.

Sheppard, M.I. and D.H. Thibault. 1990. "Default Soil Solid/Liquid Partition Coefficients, K_ds, for Four Major Soil Types: A Compendium." *Health Physics* 59(4):471-482, Philadelphia, Pennsylvania.

Till, J.E. and H.R. Meyer, eds. 1983. *Radiological Assessment: A Textbook on Environmental Dose Analysis*. NUREG/CR-3332, Oak Ridge National Laboratory, Oak Ridge, Tennessee. Accession No. ML091770419.

YAEC (Yankee Atomic Electric Company). 2006. *Groundwater Monitoring Plan to Support Closure under the Massachusetts Contingency Plan*. Rowe, Massachusetts. Accession No. ML071670009.

Appendix F

Spent Fuel Pool Fires

Appendix F

Spent Fuel Pool Fires

This appendix examines the environmental impacts of a spent fuel pool fire during the short-term storage timeframe.¹ The environmental impacts of spent fuel pool fires described in this appendix support the U.S. Nuclear Regulatory Commission's (NRC's) generic determination of the environmental impacts of spent fuel pool fires and their risk, as described in Section 4.18.2.1 of this *Generic Environmental Impact Statement for Continued Storage of Spent Nuclear Fuel* (GEIS). The NRC has conducted extensive evaluations of the risk and impacts of spent fuel pool fires. While initial studies were concerned with spent fuel pool fire risk during the operating life of a reactor, a risk study completed in 2001 examined the risk of a spent fuel pool fire during the reactor decommissioning period (NRC 2001). The analysis in this appendix shows that the probability-weighted impacts, or risk, from a spent fuel pool fire for the short-term storage timeframe are SMALL because, while the consequences from a spent fuel pool fire could be significant and destabilizing, the probability of such an event is extremely remote.

F.1 Environmental Impacts of Spent Fuel Pool Fires

In the event of an accident that leads to a loss of water in a spent fuel pool (via rapid drainage or extended boiling), without successful efforts to replenish the lost water, spent fuel temperatures could increase significantly. If cooling of the spent fuel were not reestablished, the fuel could heat up to temperatures on the order of 1,000°C (1,832°F). At this temperature, the spent fuel's zirconium cladding would begin to react with air in a highly exothermic chemical reaction called a runaway zirconium oxidation reaction or autocatalytic ignition. This accident scenario is often referred to as a "spent fuel pool zirconium fire." Radioactive aerosols and vapors released from the damaged spent fuel could be carried throughout the spent fuel pool building and into the surrounding environment. This release could lead to exposures of the surrounding population and contamination of property (e.g., land or structures) in the vicinity of the site. Under appropriate atmospheric conditions, the radioactive aerosols from very large releases could be transported long distances before they were deposited or dispersed.

¹ As discussed in Section 1.8, the NRC assumes that all spent nuclear fuel (spent fuel) is removed from the pools and placed in dry-cask storage by the end of the short-term storage timeframe. This appendix, therefore, does not analyze the impacts of a spent fuel pool fire after the short-term storage timeframe because a spent fuel pool will not be used to store spent fuel after that time.

Appendix F

Under certain conditions, the high temperature runaway zirconium oxidation reaction occurring in one part of the pool could also spread to other spent fuel in the pool. The proximity of fuel assemblies to one another, combined with the effects of radiative heat transfer when these assemblies are at very high temperatures, could allow the runaway oxidation reaction to spread from spent fuel with high decay heat to spent fuel with lower decay heat that would otherwise not have begun burning.

A spent fuel pool accident could develop into a spent fuel pool fire in a number of ways. As the NRC first determined in 1975, spent fuel pool accidents can arise from either the loss of spent fuel pool cooling, drainage of the spent fuel pool, or the dropping of heavy items into the spent fuel pool (NRC 1975). Since that time, the NRC has refined its analysis and has looked at various ways that these events could occur. For example, in 1989 the NRC conducted a study that assessed various accident sequences including spent fuel pool failure due to wind-driven missiles, aircraft crashes, heavy-load drop, seal failure, inadvertent draining, loss-of-cooling, and seismic events (NRC 1989).

The NRC has also assessed the probability of spent fuel pool accidents. The probability of spent fuel pool accidents is the sum of the frequency of those accident sequences that lead to radiological release, considering both the frequency of the different types of initiating events and the probability of a release given that a particular initiating event has occurred. In its earliest study, the NRC determined that the probability of the drainage of the spent fuel pool was much less than a loss-of-cooling event for the reactor because accidental drainage of the spent fuel pool requires multiple simultaneous failures (NRC 1975). Further, in 1989 the NRC quantified the probabilities of various accident initiating events and assessed the health and economic consequences of a spent fuel pool accident (NRC 1989). The potential consequences of a spent fuel pool fire can be considered in light of these probabilities and expressed in several different measures of impacts (e.g., collective radiation dose to the public and economic consequences).

The NRC chose to develop its generic analysis for spent fuel pool fires by selecting NUREG–1738, *Technical Study of Spent Nuclear Fuel Pool Accident Risk at Decommissioning Nuclear Power Plants* (NRC 2001) as the principle basis for its quantitative estimates of the impacts, and then discuss any significant uncertainties and how those uncertainties would affect those estimates. The NRC chose NUREG–1738 for this purpose because the following features are particularly relevant to the spent fuel pool severe accident analysis of the GEIS:

- NUREG–1738 was developed for reactors during decommissioning rather than operating reactors, and thus analyzes the earliest and highest-risk period of the short-term storage timeframe considered in the GEIS.
- NUREG–1738 analyzes a wide variety of initiating events.

- NUREG–1738 was developed as a generic analysis by, for example, considering geographic variation in seismic hazard (see Figure 3.2 of NUREG–1738) and by performing sensitivity studies to examine the effects of variation in site-specific factors such as population density.
- NUREG–1738 references preceding studies of spent fuel pool risks and compares the results, thereby serving as a valuable update to earlier spent fuel pool risk studies.
- NUREG–1738 has received extensive peer technical review and public comment.
- NUREG–1738 provides quantitative estimates at a reference reactor site (i.e., Surry Power Station [Surry]) for which information on the impacts of potential reactor accidents is also available, allowing a comparison of potential impacts of both pool and reactor accidents.

As detailed in the following sections, the impacts from a spent fuel pool fire are expressed in terms of both the consequence that would occur if the accident occurred and as a probability-weighted consequence. The probability-weighted consequence, also known as risk, is a quantitative measure of the severity of the accident that accounts for the likelihood of its occurrence. The probability-weighted consequence is calculated by multiplying a consequence, such as cumulative dose, cost to the local economy, or area of land contamination, by the probability of the accident's occurrence. In the following analyses, the NRC first provides a discussion of the consequences of a spent fuel pool fire. The NRC then determines the risk of a spent fuel pool fire by looking at the probability of this type of event during the short-term storage timeframe and multiplying the probability by the consequences. The probability-weighted consequences provide the expected environmental impacts of a spent fuel pool fire, and represent the NRC's best forward-looking judgment concerning spent fuel pool fire risk during the short-term storage timeframe.

As discussed in more detail below, the NRC confirmed that the overall risks associated with these types of accidents remain low because the spent fuel pool loss-of-cooling event probability is low (NRC 2001). As discussed in more detail in Section F.1.2, since the NRC completed NUREG–1738 in 2001, the NRC has continued to implement regulations and orders that further reduce the likelihood of a spent fuel pool fire. These additional reductions in the likelihood of a spent fuel pool fire mean that the risks are lower now than those NRC reported in NUREG–1738.

Finally, as part of an ongoing examination of the risk of spent fuel pool accidents, the NRC performed a study of the probability and consequences of a beyond-design-basis earthquake affecting the spent fuel pool for a U.S. boiling water reactor. That study, documented in SECY–13–0112, *Consequence Study of a Beyond-Design-Basis Earthquake Affecting the Spent Fuel Pool for a U.S. Mark I Boiling Water Reactor* (NRC 2013a), used updated methods to look at the probability and consequences of a spent fuel pool loss-of-cooling event for both a high-density and a low-density loading spent fuel storage configuration. Based in part on that study, the NRC performed an analysis of spent fuel pool fire risk to determine whether the NRC should

conduct additional research on the potential need to require reactor licensees to accelerate transfer of older, cooler spent fuel from the spent fuel pool to dry cask storage. The results of this analysis were documented in COMSECY-13-0030 (NRC 2013a). The results in SECY-13-0112 and COMSECY-13-0030 support the NRC's conclusion that, while the consequences from a spent fuel pool fire could be significant and destabilizing, the probability of a spent fuel pool fire is extremely remote. Further, the NRC reviewed the analyses in SECY-13-0112 and COMSECY-13-0030 and determined that neither would be an appropriate technical basis for the generic spent fuel pool fire consequence analysis in the GEIS. SECY-13-0112 lacked features comparable to NUREG-1738 that would support a generic analysis of continued storage, while COMSECY-13-0030 was drafted to satisfy a limited purpose, did not contain a NEPA analysis, and was not intended to satisfy the NRC's NEPA obligation. While important information has been garnered from those analyses, the NRC continues to believe that the analysis in NUREG-1738 is the appropriate technical basis from which to evaluate the impacts from a spent fuel pool fire during the short-term timeframe because of the factors described earlier in this section.

F.1.1 Consequences of a Spent Fuel Pool Fire

The release of radionuclides into the environment resulting from a spent fuel pool fire can lead to severe consequences, both in terms of direct human health impacts (e.g., early fatalities or latent cancer fatalities) and economic damages arising from the actions taken to avoid human exposures (e.g., evacuation and relocation costs, costs for cleanup of contaminated land, and the loss of economic value associated with land that cannot be used following a severe accident). These consequences do not consider the probability that an accident will occur. Possible initiating events and the probability that these events could occur are discussed in Section F.1.2. The following discussion and Table F-1 examine the consequences of a spent fuel pool fire.

In NUREG-1738 and Table F-1, source terms for high ruthenium (Ru) and low Ru are expressed as ranges. For example, the total collective dose for the high Ru source term ranges from 1.34×10^5 to 2.37×10^5 person-Sv (1.34×10^7 to 2.37×10^7 person-rem).³ The ranges in Table F-1 are mean values of consequences of a spent fuel pool fire in which the NRC assumed a late evacuation of 95 percent of the population inside the 16-km (10-mi) emergency planning zone around Surry. The late evacuation assumption means that evacuation is started after the release. The low value corresponds to a fire that occurs 10 years after shutdown, at which time

³ A person-Sievert (person-Sv) is a unit of collective dose. Collective dose is the sum of individual radiation doses received by a population. The incidence of health effects will vary from no observable health effects in large numbers of exposed individuals that receive low doses to observable health effects in small numbers of exposed individuals that receive large doses. Population health effects from spent fuel fires, including early fatalities and latent cancer fatalities, are summarized in Table F-1.

radioactive decay has reduced the amount of radioactive material that could be released. The high value corresponds to a fire that occurs within 30 days after shutdown.

Table F-1. Spent Fuel Pool Accident Probability and Consequences^(a)

	<u>Individual Risk per Event</u>				Collective Early Fatality per Event (10 mi) ^(c)	Latent Fatality ^(d) (0–500 mi)	Total Onsite and Offsite Economic (million \$ per event)
	Accident Frequency (per year) ^(b)	Early Fatality (1 mi) ^(c)	Latent Fatality (10 mi) ^(c)	Total person-Sv per Event			
NUREG–1738 (high Ru)	$5.8 \times 10^{-7(e)}$ to $2.4 \times 10^{-6(f)}$	4.68×10^{-3} to 4.43×10^{-2}	6.39×10^{-2} to 8.49×10^{-2}	1.34×10^5 to 2.37 $\times 10^5$ (50 mi) ^(c)	<1 (0.360) to 191	-	-
NUREG–1738 (low Ru)	$5.8 \times 10^{-7(e)}$ to $2.4 \times 10^{-6(f)}$	1.63×10^{-3} to 1.27×10^{-2}	1.29×10^{-2} to 1.88×10^{-2}	4.72×10^4 to 5.58 $\times 10^4$ (50 mi) ^(c)	<1 to 2	20,000– 27,000	-
NUREG–1353	2.0×10^{-6}	-	-	2.6×10^5 (50 mi) ^(g)	-	-	55,700 ^(h,i)
NUREG/ BR–0184	-	-	-	2.6×10^5 (50 mi) ^(j)	-	-	57,800 ^(h,k)

(a) All values are approximate.

(b) A value of 5.8×10^{-7} is scientific notation for a value that can also be expressed as 0.00000058. This value means that the probability of the accident occurring in any year is one chance in 1,700,000 (or one chance in 1/0.00000058).

(c) Consequence values were obtained from NUREG–1738 (NRC 2001, Tables 2 and 3 of Appendix 4B). [Note: Similar values appear in NUREG–1738 (NRC 2001, Tables 3.7-1 and 3.7-2), but were incorrectly reporting values from Appendix 4B.]

(d) Consequence values were obtained from NUREG–1738 (NRC 2001, Appendix 4) and reflect a range of results from the seven cases evaluated.

(e) Electric Power Research Institute data from NUREG–1738 (NRC 2001).

(f) Lawrence Livermore National Laboratory data in NUREG–1738 (NRC 2001).

(g) Case 2 values were obtained from NUREG–1353 (NRC 1989, Table 4.8.3). Case 2 assumed the entire spent fuel pool inventory was released.

(h) Values are based on impacts within 50 mi and are adjusted to 2010 dollars using the Consumer Price Index Inflation Calculator.

(i) Values were obtained from NUREG–1353 (30,200 Million \$ in 1988 dollars; excludes replacement power costs) (NRC 1989, Tables 5.1.1 and 5.1.2).

(j) Values were obtained from NUREG/BR–0184 (NRC 1997, Table C.101).

(k) Values were obtained from NUREG/BR–0184 (26,400 Million \$ in 1983 dollars; excludes replacement power costs) (NRC 1997, Table C.95 and C.101).

Table F-1 shows that the most severe spent fuel pool fire consequences would occur from a fire starting within 30 days after a final reactor shutdown in conjunction with a late or delayed evacuation of the affected area. The late evacuation would result in consequences more severe than those for an early evacuation because a late evacuation means that people will evacuate after the release of radioactive material. Further, the values shown in Table F-1 are conditional consequences, based on an assumption that a severe accident occurs without consideration of the remote probability of an accident. Probability-weighted consequences are discussed in Section F.1.2.

As discussed below, the assumptions described above are conservative assumptions of the consequences of the spent fuel pool fire. These conservative assumptions further reduce the

Appendix F

likelihood that the actual consequences would be as high as indicated in Table F-1. For example, the low Ru results from NUREG–1738 more realistically represent the anticipated consequences of even a high-volatility Ru spent fuel pool fire sequence. The 95 percent evacuation estimate is less than the NRC’s best estimate of actual evacuation of 99.5 percent of the populace from the 16-km (10-mi) emergency planning zone, which was used by the NRC in its 2012 *State-of-the-Art Reactor Consequence Analyses Report* (NRC 1990, 2012a). However, in NUREG–1738 the NRC used a value of 95 percent in sensitivity studies to address concerns that the fraction of the public that does not evacuate could be higher. “Late evacuation” is a reasonably conservative assumption for decay times of less than about 2 years, for which the time-to-release could be less than 10 hours. However, the time-to-release (following the initiating event) will be longer than 10 hours after the spent fuel has cooled at least 2 years, and early evacuation, in which evacuation is completed before the release begins, would be increasingly more likely as the decay time increases. The more recent analyses (i.e., SECY–13–0112) suggest that, even for accidents occurring within a few months of final shutdown and assuming mitigation measures are unsuccessful, releases could start anywhere from eight hours to several days after the event. Early evacuation results in lower public doses because more people will evacuate before release occurs. Finally, the main contributors to the likelihood of uncovering the spent fuel are seismic events and cask drop. These events are no more or less likely to occur in any particular time interval during continued storage. Therefore, the probability of these initiating events occurring within the first 30 days after shutdown is an order of magnitude less than the per year probability during the 60-year short-term storage timeframe.

The low Ru and high Ru values shown in Table F-1 refer to two different source terms used in NUREG–1738 (NRC 2001). The low Ru source term is based on release fractions for chemical element groups that are discussed in NUREG–1465, *Accident Source Terms for Light-Water Nuclear Power Plants* (NRC 1995). Use of the NUREG–1465 source term means that the consequence estimates in the GEIS are based on a 75 percent release of radioiodine and radiocesium, the two radioisotope groups that contribute the most to offsite consequences. In addition, NUREG–1738 considered uncertainties associated with the Ru group and fuel fines component of the NUREG–1465 release fractions. The fuel fines component of the source term, comprised of small particles of spent fuel, is represented by the element groups for cerium and lanthanum. To conservatively address potential uncertainties in the source term, NUREG–1738 computed consequences for a modified source term that assumed a 75 percent release fraction for ruthenium and a 3.5 percent release fraction for lanthanum and cerium, referred to as the “high Ru source term.” The higher release fraction for Ru in the high Ru source term is the same fraction as those used for volatile fission products like isotopes of iodine and cesium. As stated in NUREG–1738, the higher release fractions for lanthanum and cerium in the high Ru source term are based on a 1995 study of the Chernobyl accident.

As described in NUREG–1738, Ru in a steam environment has a very low vapor pressure that tends to limit its release (NRC 2001). For spent fuel pool accidents involving rapid draindown of

the pool, and thus primarily an air environment during fuel heat up, the volatility of Ru might be much higher. Recent modeling suggests that Ru release in an air environment would in fact be much higher than in a steam environment, but still several orders of magnitude below the release fractions used for the high Ru release in NUREG–1738 (Gauntt 2010). For this reason, the low Ru results from NUREG–1738 (NRC 2001) are more representative of the anticipated consequences of even a high-volatility Ru spent fuel pool fire sequence.

The NRC assesses the consequences of a spent fuel pool fire and other severe accidents in terms of health impacts and economic damages. The health impacts from spent fuel pool fires are measured through both individual impacts at select locations, and overall population consequences. Health impacts include the early fatality risk to an individual within 1.6 km (1 mi) of the plant and the latent fatality risk to an individual within 16 km (10 mi) of the plant. These health impacts represent possible exposures and consequences to the population near a nuclear facility. Early fatalities are the number of fatalities expected to occur within a few weeks or months of the accident for the individuals exposed to large doses of radiation. Latent fatalities are the number of cancer-related fatalities that occur over the lifetime of the exposed individuals.

Other health impacts that the NRC considers include collective dose to the public within 80 km (50 mi) of the plant, and the collective latent fatalities within 800 km (500 mi) of the plant (NRC 2001). The collective dose is the dose received by the total population living within a specific distance from the facility, including return dose and the dose to workers during decontamination of contaminated land; this value depends upon the site-specific population within a specific distance of the plant. In Table F-1, health effects taken from NUREG–1738 (NRC 2001) are based on a postulated spent fuel pool fire at Surry releasing a large fraction (i.e., approximately 75 percent of the iodine and cesium) from a radiological inventory consisting of its final core offload plus its previous ten refueling outages, which is equivalent to approximately 3.5 cores. A similar scenario examined in NUREG–1353 (NRC 1989) and NUREG/BR–0184 (NRC 1997) involved releasing a large fraction (i.e., 100 percent of the iodine and cesium) from a radiological inventory consisting of 3.5 cores of spent fuel from the R.E. Ginna nuclear power plant and an 80-km (50-mi) average population density of 330 persons/km² (860 persons/mi²) (based on the population around the Zion Nuclear Power Station [Zion] in Illinois). In general, health impacts could be higher or lower than the values reported in these studies if the amount of radioactive material that could be released (which depends on the amount of material in the pool and the fraction of that material involved in the fire) were higher or lower than assumed in these studies or the total population and population density were higher or lower.

For perspective, the radiological inventory of Cs-137 from NUREG–1738 (NRC 2001) can be computed as approximately 40 MCi of Cs-137, and the radiological inventory from NUREG–1353 (NRC 1989) was computed to be approximately 20 MCi. These values are somewhat lower than the average values reported in COMSECY–13–0030 (NRC 2013b).

Appendix F

Table 72 from COMSECY-13-0030 illustrates that the radiological inventory of Cs-137 in high-density storage at nuclear power plants can range from 20.4 to 175.4 MCi of Cs-137, assuming each spent fuel pool is at its licensed capacity of spent fuel in storage. Conversely, the release fractions assumed in NUREG-1738 (i.e., 75 percent of the radioiodine and radiocesium) or NUREG-1353 (i.e., 100 percent of the radioiodine and radiocesium) are higher than the release fractions computed in more recent studies (e.g., SECY-13-0112 [NRC 2013a], which estimated cesium release fractions from 49 percent to less than 1 percent). Therefore, although the total radiological inventory at a given site might be higher than the values used in NUREG-1738 (NRC 2001) and NUREG-1353 (NRC 1989), the release fraction would likely be significantly lower than that assumed in either report.

Likewise for population, Table 53 of COMSECY-13-0030 shows the distribution of population density around nuclear power plant sites in the United States (NRC 2013b). The average population density within 80 km (50 mi) of U.S. nuclear power plant sites is approximately 120 persons/km² (300 persons/mi²), consistent with the Surry site. The average population around the Zion site of 330 persons/km² (860 persons/mi²) is greater than the 90th percentile population density of approximately 270 persons/km² (700 persons/mi²). As discussed in NUREG-1738 (NRC 2001), the use of the Surry site means that the accident consequences could be greater at higher population sites, but the quantitative health objectives used in NUREG-1738 for comparisons to the Commission's safety goals represent the risk to the average individual within 1.6 km (1 mi) and 16 km (10 mi) of the plant. That risk should not vary significantly with the size of the site-specific population around a plant because those risks are averaged (i.e., determined by dividing the total number of cases by the affected population within the specified region).

Health impacts can also be affected by protective action guidelines, or the radiation dose levels above which emergency response officials will recommend protective actions like evacuation or sheltering. Higher protective action guidelines could increase public doses by allowing people to remain in affected locations longer or by reducing the area that would be subject to long-term actions (e.g., decontamination or interdiction). Different types of radioactive material can also change health impacts. For example, early fatalities would likely be caused by short-lived radioactive material that is present in operating reactors. Once spent fuel has been removed from a reactor and stored in the spent fuel pool, short-lived radioactive material will decay to such low levels that accidents would result in fewer early fatalities in the surrounding population.

The NRC also analyzes consequences in terms of the economic consequences arising from the actions taken to avoid human exposure. The economic consequences identified in Table F-1 take into account various costs, including offsite and onsite property damage resulting from the release of radioactive material and the resulting land contamination. Offsite property damage includes evacuation costs, relocation costs for displaced persons, property decontamination costs, loss of use of contaminated property through interdiction, crop, and milk losses. The

onsite property damage costs include onsite cleanup and decontamination, repair of the spent fuel pool, and removal of fuel. The total onsite and offsite economic damage values were estimated to be between 55.7 and 57.8 billion dollars per event (NRC 1989, 1997), when adjusted to 2010 dollars.

These values represent the economic consequences out to 80 km (50 mi), which is consistent with how NRC typically examines offsite property impacts from reactor accidents (NRC 1997). For very large releases (e.g., those that are possible in the event of a spent fuel pool fire), aerosols can potentially be transported beyond 80 km (50 mi) under appropriate atmospheric conditions. This effect can be seen in the NRC's more recent analysis in SECY-13-0112 (NRC 2013a) by comparing the consequences from an accident in which mitigation is credited—which would lead to a smaller release—to the consequences of an accident in which no mitigation is credited. For example, Tables 35 and 36 of SECY-13-0112 show that land interdiction and relocation of individuals, respectively, could occur well beyond the range of 80 km (50 mi) in the event of a very large release from the spent fuel pool. As with health impacts, the economic impacts would vary for different facilities. For example, higher total population or population density, higher property values, and higher level of protective action guidelines in place, could result in higher relocation costs, and land use (e.g., whether land is used as farmland or not) could also impact decontamination and condemnation costs. For perspective, the population density used to estimate the economic impacts presented in Table F-1 involved an 80-km (50-mi) average population density of 330 persons/km² (860 persons/mi²) based on the population around the Zion in Illinois (NRC 1989, 1997). This population density is slightly higher than the 90th percentile population density reported in Table 53 of COMSECY-13-0030 (NRC 2013b). Although the economic consequences could be higher or lower at a specific site, the site-specific factors that influence the magnitude of the economic consequences of a spent fuel pool would have a similar influence on the magnitude of the economic consequences of a reactor accident. Because of this, when put in the context of the probability of an accident occurring, the probability-weighted economic consequences of a spent fuel pool fire at a given site can be compared to the probability-weighted consequences of a reactor accident at the same site. This is discussed further in Section F.1.2.

Although discussed in more detail in the next section, Table F-1 also includes probability and consequence values for a spent fuel pool fire (NRC 1989, 1997, 2001). As shown in Table F-1, the zirconium cladding fire probability in the 1989 regulatory analysis was calculated as $2 \times 10^{-6}/\text{yr}$, which is almost identical to the $2.4 \times 10^{-6}/\text{yr}$ probability from NUREG-1738 (NRC 2001) that the NRC is using for this appendix.

F.1.2 Probability-Weighted Consequences of a Spent Fuel Pool Fire

As discussed in Section 4.18.2.1, with respect to severe (or beyond-design-basis) accidents, the consequences of a severe accident, should one occur, would be significant and destabilizing. The impact determinations for these accidents, however, are made with consideration of the low

Appendix F

probability of these events. The environmental impact determination with respect to severe accidents, therefore, is based on the risk, which the NRC defines as the product of the probability and the consequences of an accident. This means that a high-consequence, low-probability event, like a severe accident, could still result in a small impact determination, if the risk is sufficiently low.

The NRC has considered a number of initiating events that could lead to a spent fuel pool fire. These events include loss of offsite power, internal fires, loss of pool cooling, loss-of-coolant inventory, seismic event, cask drop, aircraft crash, and a tornado missile (NRC 2001). These initiating events are discussed in more detail below and, as supplemented by the overall discussion of accidents in Section 4.18 of this GEIS, provide the range of credible initiating events for spent fuel pool fires.

The main contributors to the frequency of loss-of-coolant in the pool and exposure of the spent fuel to air are seismic events and cask drop (NRC 2001). The low frequency of other events, (e.g., loss of offsite power, internal fires, loss of pool cooling, and loss-of-coolant inventory) were found in NUREG–1738 to be low on the basis of specific industry decommissioning commitments and staff decommissioning assumptions discussed in Sections 3.3 and 3.4 of NUREG–1738 (NRC 2001). As shown in Table F-1, for the credible initiating events considered, the NRC has determined that, considering the range in seismic hazard across the United States, the mean value of the frequency of fuel being uncovered could be between $5.8 \times 10^{-7} \text{ Ryr}^{-1}$ and $2.4 \times 10^{-6} \text{ Ryr}^{-1}$ depending upon the seismic hazard assessment (NRC 2001).⁵ Although some sites could have a value greater than $1 \times 10^{-5} \text{ Ryr}^{-1}$, the value used in NUREG–1738 bounds about 70 percent of the sites using the Lawrence Livermore National Laboratory hazard curves. These values are consistent with those used in COMSECY–13–0030 (NRC 2013b), where the likelihood of a release was judged in Table 43 to range from 5.5×10^{-7} to $3.5 \times 10^{-5} \text{ Ryr}^{-1}$, with a best estimate on the order of $5.5 \times 10^{-6} \text{ Ryr}^{-1}$. For sites where seismically induced radiological release frequency exceeded the mean, the NRC determined in NUREG–1738 that based on the generic spent fuel pool fragility analysis, the seismic risk at all but four sites—which included three western plants for which updated seismic hazard information was not available—was below the value consistent with the large early release frequency criterion for managing reactor risk (i.e., $1 \times 10^{-5} \text{ Ryr}^{-1}$) (NRC 2001). Further, the NRC is requiring all operating reactor licensees to perform an updated seismic hazard evaluation for each site, which will include an evaluation of spent fuel pool seismic risk (NRC 2012b). Should new information indicate spent fuel pool risk is significantly greater than

⁵ The seismic risk analysis performed in NUREG–1738 was based on site-specific seismic hazard estimates for nuclear power plants in the central and eastern United States found in NUREG–1488, “Revised Livermore Seismic Hazard Estimates for 69 Nuclear Power Plant Sites East of the Rocky Mountains” (NRC 1994). As such, nuclear power plants in the western United States (e.g., Diablo Canyon, San Onofre, and Columbia) were not specifically considered in this study.

previously considered, the NRC would take the appropriate regulation action to ensure protection to public health and safety. Seismic risk, in general, is discussed in more detail in Section 4.18. However, because of the reduction in both the radionuclide inventory due radioactive decay and the heat generated by the spent fuel, the greatest risk from a spent fuel pool fire would be at the beginning of the short-term timeframe, and risk would decrease over time.

On the issue of boiloff events, NUREG–1738 (NRC 2001) found that, given the industry decommissioning commitments and staff decommissioning assumptions, the likelihood of boiloffs from all causes was comparable to the likelihood of fuel uncover from a cask drop or to the likelihood of a seismically induced pool failure based on the EPRI seismic hazard estimates, and approximately an order of magnitude lower than the likelihood of a seismically induced pool failure based on the Lawrence Livermore National Laboratory seismic hazard estimates. Slow boiloff events can lead to an accident progression qualitatively similar to a partial draindown or a slow draindown. However, the time before the water in the spent fuel pool would heat up and boil off would vary based on the decay power of the spent fuel in the pool. Boiloff events are discussed in Section 3.7.2 of NUREG–1738. As the short-term timeframe considered in this GEIS can last up to 60 years after final shutdown, the drop in decay power of the fuel would lead to a boiloff scenario that proceeds increasingly slowly with the passage of time. In general, decay power is dominated by the most recently discharged fuel, as shown in the comparison of a high- and low- density loading pool configuration found in Section 6.3.1 of SECY–13–0112 (NRC 2013a). The effect that reduced decay power has on time available for pool recovery is demonstrated by Table 2.1 of NUREG–1738 (NRC 2001), which shows that the time until fuel uncover ranges from at least 4 days at 60 days following shutdown to more than 22 days at 10 years following shutdown. As the spent fuel continues to cool following the permanent cessation of operation, the increasingly slow rate of boiloff that results renders pool recovery increasingly likely with the passage of time. Based on significant time between the initiating event and the spent fuel assemblies becoming partially or completely uncovered, the licensee and State and Federal authorities would have time to initiate appropriate mitigating actions to prevent a spent fuel pool fire, and if a release is projected to occur, for offsite agencies to take protective actions to protect the health and safety of the public. Although the environment near a pool undergoing boiloff could make pool recovery challenging, the pool is an unpressurized system and the water level can be recovered with fairly simple systems. Further, in contrast to large leaks resulting from structural failure of the spent fuel pool, large volumes of water would not be needed to make up for boiloff losses. Nevertheless, boiloff events were considered in NUREG–1738 and are included in the results summarized in Table F-2.

As discussed earlier, the source term used in this GEIS is derived from the low Ru source term used in NUREG–1738. It includes both the final core offload and the previous ten refueling outage offloads (NRC 2001). The NRC estimated this to be roughly 3.5 core loads in the spent fuel pool, based on an adjusted inventory for the Millstone 1 nuclear power plant that accounted

Appendix F

for larger reactors and the fact that NUREG–1738 was limited to spent fuel pool accidents during decommissioning (NRC 2001). As discussed previously, these values are somewhat lower than those reported in COMSECY–13–0030 (NRC 2013b). In addition, the NRC considered a range of times in which the event could occur after shutdown, including 30 days, 90 days, 2 years, 5 years, and 10 years after final shutdown (NRC 2001).

Table F-2. Comparison of Frequency-Weighted Consequences from Reactor Accidents and Spent Fuel Pool Fires

Accident Type	Individual Risk			Population Risk		
	Early Fatalities (within 1 mi) (Ryr ⁻¹)	Latent Fatalities (within 10 mi) (Ryr ⁻¹)	Collective Dose (person-Sv Ryr ⁻¹)	Early Fatalities (Ryr ⁻¹)	Latent Fatalities (Ryr ⁻¹)	Economic Damage (\$ Ryr ⁻¹) ^(a)
Severe Reactor Accident ^(b)	1.5×10^{-8}	1.5×10^{-9}	0.06	2.0×10^{-6}	5.2×10^{-3}	$1.1 \times 10^{5(c)}$
Spent Fuel Pool Fire ^(d)	3.9×10^{-9} to 3.0×10^{-8}	3.1×10^{-8} to 4.5×10^{-8}	0.11 to 0.13	1.9×10^{-7} to 5.3×10^{-6}	5.6×10^{-3} to $5.9 \times 10^{-3(e)}$	$1.0 \times 10^{5(f)}$ to $1.1 \times 10^{5(g)}$

- (a) Values adjusted to 2010 dollars using the Consumer Price Index Inflation Calculator.
- (b) From NUREG–1150 for Surry Power Station (NRC 1990), except for economic damage (see Note (c)).
- (c) From NUREG–1437, Supplement 6, Surry Power Station Units 1 and 2 (NRC 2002), without public exposure costs.
- (d) From NUREG–1738 (NRC 2001, Table 3.7-2 late evacuation and Table 3.1 total fuel uncover frequency assuming Lawrence Livermore National Laboratory seismic hazard), except population latent fatality and economic damage risks.
- (e) From NUREG–1738, (NRC 2001, Tables A4-7 through A4-9), which reflect a range of the three Surry cases evaluated, for distances up to 160 km (100 mi), and between 30 days and 1 year decay time prior to the accident. Event frequency is 2.4×10^{-6} Ryr⁻¹ (NRC 2001).
- (f) NUREG/BR–0184 (NRC 1997, Tables C.95 and C.101), without replacement power costs.
- (g) From NUREG–1353 (NRC 1989, Tables 4.8.3, 5.1.1, and 5.1.2), without replacement power costs.

Spent fuel is susceptible to ignition (i.e., a runaway oxidation reaction) only if the fuel is not air-coolable in the event of water loss. There may be many scenarios where the fuel is air-coolable. For example, for the specific conditions analyzed in SECY–13–0112 (NRC 2013a), the NRC found that the fuel was air-coolable (defined in that study as no radioactive release within 72 hours) about two months after reactor shutdown. Because the short-term timeframe considered in this GEIS can last for up to 60 years beyond the licensed life for operation, the drop in decay power of the fuel makes air-coolability increasingly likely with the passage of time in the event of a complete loss of water. However, the effect of partial draindowns that restrict airflow can result in degraded air-cooling. As discussed in NUREG–1738 (NRC 2001), the NRC has not defined an age after which spent fuel is no longer susceptible to ignition. NUREG–1738 therefore assumed that a fire would be initiated if the water level reached 0.9 m (3 ft) from the top of the spent fuel. The quantitative impact estimates in Table F-1 and Table F-2 are based

on this assumption, with the range of quantitative impact estimates using decay times of anywhere from 30 days to 10 years after final shutdown. However, as the fuel continues to age after reactor shutdown, it will become less hazardous due to radioactive decay and the reduction of the heat generated by the spent fuel. Thus, both the consequences and risk predicted by the analysis will continue to decrease in comparison to the values in Table F-1 through the short-term timeframe because the fuel would have been cooling in the spent fuel pool for a longer period of time, which would increase the likelihood of air-coolability and decrease source term (less radionuclide inventory) due to decay, particularly for the short-lived radionuclides that would contribute the most to the potential for early fatalities.

In NUREG-1738, the NRC determined that the probability-weighted consequences of a spent fuel pool accident, including a spent fuel pool fire, could be comparable to the probability-weighted consequences of a severe reactor accident (NRC 2001). Therefore, the NRC has decided to include a comparison of the frequency-weighted consequences of a severe reactor accident to the frequency-weighted consequences of a spent fuel pool fire to provide a more complete picture of the overall risks of a spent fuel pool fire. As discussed above, the frequency-weighted consequences, or the risk, of a spent fuel pool fire represent the NRC's determination of the environmental impacts of this event.

Table F-2 provides the probability-weighted consequences (risk) resulting from a spent fuel pool fire. This table demonstrates that the probability-weighted consequences of a spent fuel pool fire are comparable to those for severe reactor accidents. Early in the short-term timeframe, the offsite health impacts of a spent fuel pool fire, as evaluated in NUREG-1738 (NRC 2001), can be comparable to those from a severe accident at an operating reactor. More recent studies, such as NUREG-1935, State-of-the-Art Reactor Consequence Analyses (SOARCA) Report (NRC 2012a) and SECY-13-0112 (NRC 2013a, respectively, suggest that probability-weighted health impacts of reactor accidents and spent fuel pool accidents would be low and well within the Commission's safety goals. In the unlikely event of an accident at either a reactor or spent fuel pool, the probability-weighted consequences of offsite economic impacts would be comparable because, while the economic impacts of a spent fuel pool fire could be larger than those from a reactor accident, a spent fuel pool accident is less likely than a reactor accident.

With the exception of the economic damage risk figures for spent fuel pool fire, all of the risk values in Table F-2 are for Surry. Economic damage risk figures for spent fuel pool fires are not available for Surry; thus, this GEIS uses available economic damage risk figures that are as similar as possible. A similar case studied previously by NRC involved 3.5 cores of spent fuel from the R.E. Ginna nuclear power plant and an 80-km (50-mi) average population density of 330 persons/km² (860 persons/mi²), which is based on the population around the Zion in Illinois (NRC 1989). Given that the analysis in this GEIS is concerned with spent fuel pool fires at nuclear power plants that have permanently ceased operations, the economic damage risk figures for spent fuel pool fires presented in Table F-2 do not include replacement power costs.

Appendix F

The costs considered include those for onsite cleanup, repair, disposal of wastes, and offsite economic damage (e.g., relocation of people and property decontamination).

The NRC is using the results for Surry because there are few stations for which quantitative risk values are available for both an onsite reactor accident and a spent fuel pool fire. The NRC believes that a comparison of severe reactor accidents and spent fuel pool fires for Surry is appropriate for this generic analysis because:

- Each of the two pressurized water reactor units at Surry generate approximately the same levels of thermal and electric power as the reference facility described elsewhere in this GEIS (838 MW(e) versus the reference value of 1,000 MW(e)), and the shared Surry spent fuel pool is licensed to store 1,044 spent fuel assemblies—the equivalent of about 4.6 full reactor cores, or about 520 MTU—which is approximately the pool capacity used elsewhere in this GEIS (520 MTU versus the reference value of 700 MTU). The NRC has determined that the differences between the Surry and the reference facility values are not significant for this impact analysis and, as noted above, the impacts can be scaled appropriately for any particular facility's surrounding population and source term characteristics.
- The consequences of a severe reactor accident will change in direct proportion to the reactor's power level. Likewise, the consequences of a spent fuel pool fire will change in direct proportion to the amount of spent fuel stored in the pool. In the case of Surry, both the reactor power level and the spent fuel pool licensed capacity are both about the same proportion lower than the reference facility described in Chapter 2 of the GEIS. As a result, the ratio of severe reactor accident risk to spent fuel pool fire risk is likely to be similar for the reference reactor described in Chapter 2.

The risk values in Table F-2 include individual risks and population risks. The individual risk values for both severe reactor accidents and spent fuel pool fires are comparable to each other and both lower than the NRC's Quantitative Health Objectives contained in its Safety Goal Policy Statement (51 FR 30028) for both individual early fatality risk (5×10^{-7} Ryr⁻¹) and individual latent fatality risk (2×10^{-6} Ryr⁻¹) (NRC 2001). As stated above, the population risk values for the two accident types are comparable. The public exposure costs are not included in the severe reactor accident economic cost-risk figures because the spent fuel pool fire economic damage risk from the reports cited did not include public exposure costs.

This analysis shows that the probability-weighted consequences for a spent fuel pool fire, as analyzed in NUREG-1738, are comparable to the probability-weighted consequences for severe power reactor accidents analyzed in the 1996 and 2013 License Renewal GEIS (NRC 1996, 2013c). Not only are spent fuel pool probability-weighted consequences comparable, but NUREG-1738 contains several built-in conservative assumptions. For example, NUREG-1738 assumed that the zirconium fuel cladding would start to burn and was nonrecoverable as soon as the water level in the spent fuel pool fell to within 0.9 m (3 ft) of the top of the fuel assemblies

(NRC 2001). However, a 2008 Denial of Petition for Rulemaking (73 FR 46204) analysis shows that there would be significant time between the initiating event and the spent fuel assemblies becoming partially or completely uncovered. In addition, air-cooling of spent fuel in the event of a complete draindown would be sufficient to prevent spent fuel pool zirconium fires at a point much earlier following fuel offload from the reactor than was considered in NUREG–1738 (73 FR 46204). Thus, more time would be available for operator intervention, which would lower the probability of a draindown event leading to a spent fuel pool fire.

Since the publication of NUREG–1738, the NRC has required licensees to undertake additional actions to further reduce the probability of a spent fuel pool fire. These additional actions resulted from insights following the September 11, 2001 terrorist attack and the March 11, 2011 Fukushima Dai-ichi accident.

In response to the September 11, 2001 terrorist attacks, the NRC imposed license conditions at most operating reactors to ensure that licensees have mitigating strategies in place for attacks on spent fuel pools. Those conditions would remain in place after shutdown. Where license conditions are not in place, the NRC has determined, based on site-specific physical characteristics, that the spent fuel pool is not susceptible to being breached and drained of cooling water. These requirements were codified in 10 CFR 50.54(hh)(2). While the requirements of 10 CFR 50.54(hh)(2) are currently not applicable for spent fuel pools at decommissioning reactors, the NRC is considering rulemaking to, among other things, apply the requirements of 10 CFR 50.54(hh)(2) to decommissioning facilities with spent fuel still in a spent fuel pool. See rulemaking docket NRC-2011-0299, “Station Blackout Mitigation” for more information. Other organizations, such as Sandia National Laboratory, have confirmed the effectiveness of the additional mitigation strategies to maintain spent fuel cooling in the event the pool is drained and its initial water inventory is reduced or lost entirely (73 FR 46204). Generic strategies for spent fuel pool cooling are further discussed in a publication prepared by the Nuclear Energy Institute, a nuclear industry policy group, in NEI–06–12, Revision 2 (NEI 2006), which has been endorsed by the NRC. As a result of these additional actions, NRC has concluded that the probability of an initiating event leading to a spent fuel pool fire is less likely than analyzed in the NUREG–1738 (NRC 2001) and previous studies (73 FR 46204). Therefore, the analysis provided in Table F-2, based upon NUREG–1738, is a conservative estimate of spent fuel pool risk.

The NRC conducted additional evaluations to assess its regulatory framework in response to the March 2011 Fukushima Dai-ichi events. On March 11, 2011, a massive earthquake off the east coast of Honshu, Japan, produced a devastating tsunami that struck the coastal town of Fukushima. The six-unit Fukushima Dai-ichi nuclear power plant was most directly affected by these events. Damage to the systems and structures of the reactor building resulted in the release of radioactive material to the surrounding environment. While this accident led to a substantial release of radioactive material, the fuel stored in the spent fuel pools was not

Appendix F

uncovered and the event did not lead to a spent fuel pool fire. Information on the event indicates that spent fuel pool cooling was lost for all spent fuel pools following the loss of offsite power (INPO 2011). But subsequent analyses and inspections confirmed that the spent fuel pool water levels did not drop below the top of the fuel in any of the spent fuel pools and no significant damage occurred to the fuel in the pools. These events demonstrate that, even without spent fuel cooling for multiple days, the pools were able to keep the spent fuel cool (INPO 2012).

In response to the earthquake, tsunami, and resulting reactor accidents at Fukushima Dai-ichi, the Commission directed the staff to convene an agency task force of senior leaders and experts to conduct a methodical and systematic review of the relevant NRC regulatory requirements, programs, and processes, including their implementation, and to recommend whether the agency should make near-term improvements to its regulatory system. As part of the short-term review, this Near-Term Task Force concluded that some additional improvements to spent fuel pool storage and other structures, systems, and components would be beneficial. In NRC Order EA-12-049, the NRC required operating reactor licensees to implement mitigating strategies to ensure that spent fuel pool cooling can be accomplished through alternative means to prevent fuel damage (NRC 2012c). In addition, in NRC Order EA-12-051, the NRC determined that operating reactor licensees must have a reliable means to remotely monitor a wide-range of spent fuel pool levels to support effective prioritization of event mitigation and recovery actions in the event of a beyond-design-basis external event (NRC 2012d).

As part of the agency's Station Blackout Mitigation rulemaking, the NRC is considering a variety of requirements that would further decrease the probability of a spent fuel pool fire during the short-term timeframe. Among the options being evaluated as part of this rulemaking is the need to require licensees of decommissioning facilities to develop mitigating strategies to restore spent fuel pool cooling, similar to what is now required of operating reactor licensees. These measures would further reduce the probability of a spent fuel pool fire, and thus further increase the conservatism of the estimate of spent fuel pool risk provided in Table F-2.

F.1.3 Conclusion

In summary, the conservative estimates that the NRC is using to assess spent fuel pool fire accidents, based upon NUREG-1738 and other analyses, results in probability-weighted population doses and economic consequences that are comparable to the values calculated for a severe reactor accident, as estimated in the 1996 and 2013 License Renewal GEIS (NRC 1996, 2013c). Further, mitigation measures implemented by licensees as a result of NRC orders and regulations adopted since NUREG-1738 have further lowered the probability and risk of a spent fuel pool fire. As a result, the NRC finds that the environmental impacts from spent fuel pool fires are SMALL during the short-term storage timeframe.

F.2 References

F.2.1 Summary of Major Studies Considered in this Appendix

One of the earlier spent fuel pool accident studies considered by the NRC was *Reactor Safety Study: An Assessment of Accident Risks in U.S. Commercial Nuclear Power Plants* (NRC 1975). The Reactor Safety Study provides a systematic quantification of commercial nuclear reactor accident probabilities. Appendix I of the Reactor Safety Study covers various accidents, including spent fuel pool accidents. The Reactor Safety Study states that spent fuel pool accidents can arise from either loss of spent fuel pool cooling, drainage of the spent fuel pool, or dropping of heavy items into the spent fuel pool. The Reactor Safety Study also indicates that the probability of a loss-of-cooling event is small at less than 0.1 events per year. The Reactor Safety Study used this information to estimate the probability of fuel damage due to loss of pool cooling. This study examined drainage of the spent fuel pool and concluded that the probability of drainage is much lower than for a loss-of-cooling event because drainage would require multiple failures to occur simultaneously. In addition to loss-of-cooling accidents, the Reactor Safety Study examined mechanical failure, both for dropping a cask into the spent fuel pool or due to an earthquake. This study concluded that the risks for a spent fuel pool accident were orders of magnitude below those involving the reactor core because of the robust design of the spent fuel pool.

In 1989, the NRC completed a generic analysis of potential accidents in spent fuel pools, *Regulatory Analysis for the Resolution of Generic Issue 82, 'Beyond Design Basis Accidents in Spent Fuel Pools'* (NRC 1989). This analysis reexamined spent fuel pool fires because 1) spent fuel pool storage had been expanded, including use of high-density storage racks and 2) new research had provided evidence of the possibility of fire propagation between assemblies in an air-cooled environment. This generic analysis examined the various spent fuel pool and spent fuel storage rack designs. The NRC used this information to assess various accident sequences, including failure due to missiles, aircraft crashes, heavy-load drop, seal failure, inadvertent draining, loss-of-cooling, and seismic events. The NRC quantified the probabilities of these initiation events and assessed both the health and economic consequences.

The safety and environmental effects of spent fuel pool storage were further addressed in conjunction with regulatory assessments of permanently shutdown nuclear plants and decommissioning nuclear power plants. NUREG/CR-6451, *A Safety and Regulatory Assessment of Generic BWR and PWR Permanently Shutdown Nuclear Power Plants* (Travis et al. 1997), addressed the appropriateness of regulations (e.g., requirements for emergency planning and insurance) associated with spent fuel pool storage. The study also provided bounding estimates for offsite consequences for the most severe accidents, which would involve draining of the spent fuel pool (e.g., complete draining of the spent fuel pool occurs 12 days after shutdown of the reactor).

Appendix F

In 2001, the NRC published the results of its technical study on spent fuel pool accident risk at decommissioning nuclear power plants. This study, NUREG–1738, *Technical Study of Spent Nuclear Fuel Pool Accident Risk at Decommissioning Nuclear Power Plants*, also examined spent fuel pool zirconium fires (NRC 2001). The NRC's analyses showed that, although the consequences for a spent fuel pool fire could be high, the risk (probability-weighted consequence) would be low because the loss-of-coolant event frequency is low. The NRC's analysis was based on a spent fuel pool at a decommissioning nuclear power plant but included times shortly after plant shutdown. Therefore, the study included analysis of accident conditions for spent fuel that had various amounts of decay heat. The risk analyses included sensitivity studies to evaluate scenarios in which members of the public residing near the plant did not evacuate as promptly as expected, given emergency preparedness requirements. This analysis assumed a spent fuel pool inventory equivalent to 3.5 reactor cores, a much more densely packed pool than assumed by the 1975 Reactor Safety Study. Further, NUREG–1738 included core loads with an average fuel burnup of 60 gigawatt-days/metric ton uranium, which is consistent with high-burnup fuel. This study represents the NRC's current judgment as to the expected impacts from a spent fuel pool fire during the short-term storage timeframe.

In 2013, the NRC completed *Consequence Study of a Beyond-Design-Basis Earthquake Affecting the Spent Fuel Pool for a U.S. Mark I Boiling Water Reactor*, which was published as SECY–13–0112 (NRC 2013a). This study continued the NRC's examination of the risks and consequences of postulated spent fuel pool accidents. The purpose of this study was to determine if accelerated transfer of older, cooler spent fuel from the spent fuel pool at a reference plant to dry cask storage would significantly reduce risks to public health and safety. The specific reference plant used for this study was a GE Type 4 BWR with a Mark I containment. This study presented a detailed analyses using state-of-the-art, validated, deterministic methods and assumptions, as well as probabilistic insights where practical. Previous studies had shown that earthquakes present the dominant risk for spent fuel pools, so this analysis considered a severe earthquake with ground motion stronger than the maximum earthquake reasonably expected to occur for the reference plant, which would challenge the spent fuel pool integrity. The study considered two spent fuel configurations—high-density and low-density loading—and the successful and unsuccessful deployment of 10 CFR 50.54(hh)(2) mitigation. The results of SECY–13–0112 are consistent with earlier research conclusions that spent fuel pools are robust structures that are likely to withstand severe earthquakes without leaking. The results of SECY–13–0112 show that the overall level of safety with respect to spent fuel storage in a spent fuel pool currently achieved at the reference plant is high and that the level of risk at the reference plant is very low.

In 2013, the NRC performed an evaluation of whether additional study of expedited transfer of spent fuel from spent fuel pools might be warranted. This evaluation was documented in COMSECY–13–0030 (NRC 2013b). For this analysis, the NRC evaluated the merits of additional research by comparing the status quo to a scenario in which expedited transfer would

be required. The NRC's analysis in COMSECY-13-0030 expanded upon the regulatory analysis in SECY-13-0112 (NRC 2013a) by covering spent fuel pool designs used in operating and decommissioned reactors in the United States. To determine if additional studies were needed, the NRC conducted a two-part analysis of expedited transfer. The NRC first assessed the potential safety benefits by using the Commission's 1986 Safety Goal Policy Statement. The NRC then proceeded to perform a cost-benefit analysis to provide additional information for the Commission's consideration. Despite the large releases for some low-probability accident progressions analyzed, the projected consequences indicated that there would be no offsite early fatalities from acute radiation effects. In addition, the NRC found that the added costs involved with expedited transfer of spent fuel to dry cask storage in order to achieve the low-density loading spent fuel pool storage alternative were not warranted in light of the benefits from expedited transfer. Based on the generic assessment and the other considerations detailed in COMSECY-13-0030 (NRC 2013b), the NRC found that additional studies were not needed to reasonably conclude that the expedited transfer of spent fuel to dry cask storage would provide only a minor or limited safety benefit (i.e., below the safety goal screening criteria), and that expected implementation costs would not be warranted. In 2014, the NRC closed the Tier 3 Japan lessons learned activity related to expedited transfer of spent fuel; however, the Commission directed the NRC staff to modify the regulatory analysis in COMSECY-13-0030 to explain why the "1 x 8" spent fuel pool loading configuration was not found to provide a substantial increase in safety (NRC 2014).

F.2.2 List of References

10 CFR Part 50. *Code of Federal Regulations*, Title 10, *Energy*, Part 50, "Domestic Licensing of Production and Utilization Facilities." Washington, D.C.

51 FR 30028. August 4, 1986. "Safety Goals for the Operations of Nuclear Power Plants; Policy Statement, Republication." *Federal Register*, U.S. Nuclear Regulatory Commission, Washington, D.C.

73 FR 46204. August 8, 2008. "The Attorney General of Commonwealth of Massachusetts, The Attorney General of California; Denial of Petitions for Rulemaking." *Federal Register*, U.S. Nuclear Regulatory Commission, Washington, D.C.

Gauntt, R.O. 2010. *MELCOR 1.8.5 Modeling Aspects of Fission Product Release, Transport and Deposition*. SAND2010-1635, Sandia National Laboratory, Albuquerque, New Mexico. Available at <http://prod.sandia.gov/techlib/access-control.cgi/2010/101635.pdf>.

Appendix F

INPO (Institute of Nuclear Power Operations). 2011. *Special Report on the Nuclear Accident at the Fukushima Dai-ichi Nuclear Power Station*. INPO–11–005, Revision 0, Atlanta, Georgia. Available at

http://www.nei.org/corporatesite/media/filefolder/11_005_Special_Report_on_Fukushima_Daiichi_MASTER_11_08_11_1.pdf.

INPO (Institute of Nuclear Power Operations). 2012. *Lessons Learned from the Nuclear Accident at the Fukushima Dai-ichi Nuclear Power Station*. INPO–11–005 Addendum, Revision 0, Atlanta, Georgia. Available at

<http://www.wano.info/Documents/Lessons%20Learned.pdf>.

NEI (Nuclear Energy Institute). 2006. *B.5.b Phase 2 & 3 Submittal Guideline*. NEI–06–12, Revision 2, Walnut Creek, California. Accession No. ML070090060.

NRC (U.S. Nuclear Regulatory Commission). 1975. *Reactor Safety Study: An Assessment of Accident Risks in U.S. Commercial Nuclear Power Plants*. NUREG–75/014 (WASH–1400), Washington, D.C. Accession No. ML083570090.

NRC (U.S. Nuclear Regulatory Commission). 1989. *Regulatory Analysis for the Resolution of Generic Issue 82, "Beyond Design Basis Accidents in Spent Fuel Pools."* NUREG–1353, Washington, D.C. Accession No. ML082330232.

NRC (U.S. Nuclear Regulatory Commission). 1990. *Severe Accident Risks: An Assessment for Five U.S. Nuclear Power Plants*. NUREG–1150, Volume 1, Washington, D.C. Accession No. ML120960691.

NRC (U.S. Nuclear Regulatory Commission). 1994. *Revised Livermore Seismic Hazard Estimates for Sixty-Nine Nuclear Power Plant Sites East of the Rocky Mountains*. NUREG–1488, Washington, D.C. Accession No. ML052640591.

NRC (U.S. Nuclear Regulatory Commission). 1995. *Accident Source Terms for Light-Water Nuclear Power Plants*. NUREG–1465, Washington, D.C. Accession No. ML041040063.

NRC (U.S. Nuclear Regulatory Commission). 1996. *Generic Environmental Impact Statement for License Renewal of Nuclear Plants*. NUREG–1437, Washington, D.C. Available at <http://www.nrc.gov/reading-rm/doc-collections/nuregs/staff/sr1437/>.

NRC (U.S. Nuclear Regulatory Commission). 1997. *Regulatory Analysis Technical Evaluation Handbook*. NUREG/BR–0184, Washington, D.C. Accession No. ML050190193.

NRC (U.S. Nuclear Regulatory Commission). 2001. *Technical Study of Spent Nuclear Fuel Pool Accident Risk at Decommissioning Nuclear Power Plants*. NUREG–1738, Washington, D.C. Accession No. ML010430066.

NRC (U.S. Nuclear Regulatory Commission). 2002. *Generic Environmental Impact Statement for License Renewal of Nuclear Plants, Supplement 6 Regarding Surry Power Station, Units 1 and 2*. NUREG–1437, Supplement 6, Washington, D.C. Accession No. ML023380748.

NRC (U.S. Nuclear Regulatory Commission). 2012a. *State-of-the-Art Reactor Consequence Analyses (SOARCA) Report*. NUREG–1935, Washington, D.C. Accession No. ML12332A053.

NRC (U.S. Nuclear Regulatory Commission). 2012b. *Request for Information Pursuant to Title 10 of the Code of Federal Regulations 50.54(f) Regarding Recommendations 2.1, 2.3, and 9.3, of the Near-Term Task Force Review of Insights from the Fukushima Dai-Ichi Accident*. Washington, D.C. Accession No. ML12053A340.

NRC (U.S. Nuclear Regulatory Commission). 2012c. *Issuance of Order to Modify Licenses with Regard to Requirement for Mitigation Strategies for Beyond-Design-Basis External Events*. EA–12–049, Washington, D.C. Accession No. ML12054A735.

NRC (U.S. Nuclear Regulatory Commission). 2012d. *Issuance of Order to Modify Licenses with Regard to Reliable Spent Fuel Pool Instrumentation*. EA–12–051, NRC–2012–051, Washington, D.C. Accession No. ML12056A044.

NRC (U.S. Nuclear Regulatory Commission). 2013a. *Consequence Study of a Beyond-Design-Basis Earthquake Affecting the Spent Fuel Pool for a U.S. Mark I Boiling Water Reactor*. SECY–13–0112, Washington, D.C. Accession No. ML13256A334.

NRC (U.S. Nuclear Regulatory Commission). 2013b. *Staff Evaluation and Recommendation for Japan Lessons-Learned Tier 3 Issue on Expedited Transfer of Spent Fuel*. COMSECY–13–0030, Washington, D.C. Accession No. ML13329A918.

NRC (U.S. Nuclear Regulatory Commission). 2013c. *Generic Environmental Impact Statement for License Renewal of Nuclear Plants*. NUREG–1437, Revision 1, Washington, D.C. Accession No. ML13107A023.

NRC (U.S. Nuclear Regulatory Commission). 2014. Memorandum from R.C. Baval to M.A. Atorius, dated May 23, 2014, “Staff Requirements—COMSECY–13–0030—Staff Evaluation and Recommendation for Japan Lessons-Learned Tier 3 Issue on Expedited Transfer of Spent Fuel.” Washington, D.C. Accession No. ML14143A360.

Appendix F

Travis, R.J., R.E. Davis, E.J. Grove, and M.A. Azarm. 1997. *Safety and Regulatory Assessment of Generic BWR and PWR Permanently Shutdown Nuclear Power Plants*. NUREG/CR-6451, Brookhaven National Laboratory, Upton, New York. Accession No. ML082260098.

Appendix G

Spent Fuel Storage Facilities

Appendix G

Spent Fuel Storage Facilities

This appendix provides summary information concerning spent nuclear fuel (spent fuel) pools and independent spent fuel storage installations (ISFSIs), which are located primarily at operating commercial power reactors and decommissioned reactor sites.

Table G-1 through Table G-3 provide information about spent fuel pools. Specifically, Table G-1 lists operating reactors and the capacities of their spent fuel pools. Capacities at single-unit pressurized water reactor (PWR) power plants range from 544 assemblies at the H.B. Robinson Steam Electric Plant, Unit 2 to 2,363 assemblies at the Callaway Plant and the Wolf Creek Generating Station. At boiling water reactor (BWR) power plants, spent fuel pool capacities range from 1,803 assemblies at the Brunswick Steam Electric Generating plant to 4,608 assemblies at Fermi, Unit 2.

Table G-2 indicates the capacity of spent fuel pools for power reactors under construction, namely Vogtle Electric Generating Plant, Units 3 and 4; Virgil C. Summer Nuclear Station Units, 2 and 3; and Watts Bar Nuclear Plant, Unit 2. Table G-3 provides the capacity of spent fuel pools for decommissioning reactors. As of June 30, 2014, seven decommissioning reactors at five sites have spent fuel stored in pools. These are Crystal River Nuclear Generating Plant, Unit 3; Kewaunee Power Station; Millstone Power Station, Unit 1; San Onofre Nuclear Generating Station, Units 2 and 3; and Zion Nuclear Power Station, Units 2 and 3.

Table G-4 and Table G-5 provide information about ISFSIs with general and specific licenses under Title 10 of the *Code of Federal Regulations* (CFR) Part 72, respectively. These tables indicate which storage systems are in use at the ISFSIs and, if applicable, the transportation package associated with the storage system. The tables also indicate whether the storage system or transportation package is approved for use with high-burnup fuel.¹ The ISFSIs are located at operating and decommissioning reactor sites. As of June 30, 2014, ISFSIs were operating at 64 sites. All ISFSIs are dry storage facilities except for the facility at the General Electric-Hitachi Morris Operation (GEH Morris) site, which is a wet storage facility. Table G-5 also presents information about two specifically licensed ISFSIs (the Private Fuel Storage Facility and the Idaho Spent Fuel Facility) that were never constructed.

¹ The tables do not account for storage systems or transportation packages that the NRC has approved for use with high-burnup fuel but that are not in use at this time (e.g., the HI-STORM FW system).

Appendix G

The 10 CFR Part 72 general license authorizes a nuclear power plant licensee to store spent fuel in casks approved by the U.S. Nuclear Regulatory Commission (NRC) at a site licensed to operate a power reactor under 10 CFR Part 50 or 52. An NRC-approved cask is one that has undergone a technical review of its safety aspects and has been found to be adequate to store spent fuel at a site that meets all of the NRC's requirements in 10 CFR Part 72. A licensee is required to perform an evaluation of its site to demonstrate that the site is adequate for storing spent fuel in dry casks. This evaluation must show that the cask certificate of compliance conditions and technical specifications can be met and must include an analysis of earthquake events and tornado missiles. In addition, the licensee must review its security program, emergency plan, quality assurance program, training program, and radiation protection program, and make any changes necessary to incorporate the ISFSI at the reactor site. Requirements for the general license are described in Subpart K of 10 CFR Part 72.

Under a 10 CFR Part 72 site-specific license, an applicant submits a license application to the NRC. The NRC performs a technical review of all the safety aspects of the proposed ISFSI and an environmental review in compliance with the National Environmental Policy Act. If the application is approved, the NRC issues a license that is valid for up to 40 years. A spent fuel storage license contains technical requirements and operating conditions (i.e., fuel specifications, cask leak testing, surveillance, and other requirements) for the ISFSI and specifies what the licensee is authorized to store at the site. Requirements for the site-specific license are described in Subparts A through I of 10 CFR Part 72.

Table G-1. Capacity of Spent Fuel Pools for Operating Nuclear Power Reactors

Operating Reactors	Reactor Type	Core Size (assemblies)	Commercial Operation Start Date	Pool Capacity (assemblies)	Pool Capacity (cores)	Estimated Pool Capacity (MTU)
Arkansas Nuclear One, Unit 1	PWR	177	12/19/1974	968	4.5	484.0
Arkansas Nuclear One, Unit 2	PWR	177	3/26/1980	988	4.6	494.0
Beaver Valley Power Station, Unit 1	PWR	157	10/1/1976	1,627	9.4	813.5
Beaver Valley Power Station, Unit 2	PWR	157	11/17/1987	1,690	9.8	845.0
Braidwood Station, Unit 1	PWR	193	7/29/1988	2,984	13.5	1,492.0
Braidwood Station, Unit 2	PWR	193	10/17/1988	See above (pool shared with Unit 1)		
Browns Ferry Nuclear Plant, Unit 1	BWR	764	8/1/1974	3,471	3.5	645.6
Browns Ferry Nuclear Plant, Unit 2	BWR	764	3/1/1975	3,471	3.5	645.6
Browns Ferry Nuclear Plant, Unit 3	BWR	764	3/1/1977	3,471	3.5	645.6
Brunswick Steam Electric Plant, Unit 1 ^(c,e)	BWR	560	3/18/1977	1,803	2.2	335.4
Brunswick Steam Electric Plant, Unit 2 ^(d,e)	BWR	560	11/3/1975	1,839	2.3	342.1
Byron Station, Unit 1	PWR	193	9/16/1985	2,984	13.5	1,492.0
Byron Station, Unit 2	PWR	193	8/2/1987	See above (pool shared with Unit 1)		
Callaway Plant	PWR	193	12/19/1984	2,363	11.2	1,181.5
Calvert Cliffs Nuclear Power Plant, Unit 1	PWR	217	5/8/1975	1,830	6.4	915.0
Calvert Cliffs Nuclear Power Plant, Unit 2	PWR	217	4/1/1977	See above (pool shared with Unit 1)		
Catawba Nuclear Station, Unit 1	PWR	193	6/29/1985	1,421	6.4	710.5
Catawba Nuclear Station, Unit 2	PWR	193	8/19/1986	1,421	6.4	710.5
Clinton Power Station, Unit 1	BWR	624	11/24/1987	3,796	5.1	706.1
Columbia Generating Station, Unit 2	BWR	764	12/13/1984	2,658	2.5	494.4
Comanche Peak Steam Electric Station, Unit 1	PWR	193	8/13/1990	3,373	15.5	1,686.5
Comanche Peak Steam Electric Station, Unit 2	PWR	193	8/3/1993	See above (pool shared with Unit 1)		

Table G-1. Capacity of Spent Fuel Pools for Operating Nuclear Power Reactors (cont'd)

Operating Reactors	Reactor Type	Core Size (assemblies)	Commercial Operation Start Date	Pool Capacity (assemblies)	Pool Capacity (cores)	Estimated Pool Capacity ^(b) (MTU)
Cooper Nuclear Station	BWR	548	7/1/1974	2,651	3.8	493.1
Davis-Besse Nuclear Power Station, Unit 1	PWR	177	7/31/1978	1,624	8.2	812.0
Diablo Canyon Nuclear Power Plant, Unit 1	PWR	193	5/7/1985	1,324	5.9	662.0
Diablo Canyon Nuclear Power Plant, Unit 2	PWR	193	3/13/1986	1,324	5.9	662.0
Donald C. Cook Nuclear Power Plant, Unit 1	PWR	193	8/28/1975	3,613	16.7	1,806.5
Donald C. Cook Nuclear Power Plant, Unit 2	PWR	193	7/1/1978	See above (pool shared with Unit 1)		
Dresden Nuclear Power Station, Unit 2	BWR	724	6/9/1970	3,537	3.9	657.9
Dresden Nuclear Power Station, Unit 3	BWR	724	11/16/1971	3,537	3.9	657.9
Duane Arnold Energy Center	BWR	368	2/1/1975	3,152	7.6	586.3
Edwin I. Hatch Nuclear Plant, Unit 1	BWR	560	12/31/1975	3,349	5.0	622.9
Edwin I. Hatch Nuclear Plant, Unit 2	BWR	560	9/5/1979	2,933	4.2	545.5
Fermi, Unit 2	BWR	764	1/23/1988	4,608	5.0	857.1
Fort Calhoun Station, Unit 1	PWR	133	9/26/1973	1,083	7.1	541.5
Grand Gulf Nuclear Station, Unit 1	BWR	800	7/1/1985	4,348	4.4	808.7
H.B. Robinson Steam Electric Plant, Unit 2 ^(e)	PWR	157	3/7/1971	544	2.5	272.0
Hope Creek Generating Station, Unit 1	BWR	764	12/20/1986	4,006	4.2	745.1
Indian Point Nuclear Generating, Unit 2	PWR	193	8/1/1974	1,374	6.1	687.0
Indian Point Nuclear Generating, Unit 3	PWR	193	8/30/1976	1,345	6.0	672.5
James A. FitzPatrick Nuclear Power Plant	BWR	560	7/28/1975	3,239	4.8	602.5
Joseph M. Farley Nuclear Plant, Unit 1	PWR	157	12/1/1977	1,407	8.0	703.5
Joseph M. Farley Nuclear Plant, Unit 2	PWR	157	7/30/1981	1,407	8.0	703.5
LaSalle County Station, Unit 1	BWR	764	1/1/1984	3,986	4.2	741.4
LaSalle County Station, Unit 2	BWR	764	10/19/1984	4,078	4.3	758.5
Limerick Generating Station, Unit 1	BWR	764	2/1/1986	4,117	4.4	765.8
Limerick Generating Station, Unit 2	BWR	764	1/8/1990	4,117	4.4	765.8
McGuire Nuclear Station, Unit 1	PWR	193	12/1/1981	1,463	6.6	731.5

Table G-1. Capacity of Spent Fuel Pools for Operating Nuclear Power Reactors (cont'd)

Operating Reactors	Reactor Type	Core Size (assemblies)	Commercial Operation Start Date	Pool Capacity (assemblies)	Pool Capacity (cores)	Estimated Pool Capacity ^(b) (MTU)
McGuire Nuclear Station, Unit 2	PWR	193	3/1/1984	1,463	6.6	731.5
Millstone Power Station, Unit 2	PWR	217	12/26/1975	1,346	5.2	673.0
Millstone Power Station, Unit 3	PWR	193	4/23/1986	1,860	8.6	930.0
Monticello Nuclear Generating Plant, Unit 1	BWR	484	6/30/1971	2,301	3.8	428.0
Nine Mile Point Nuclear Station, Unit 1	BWR	532	12/1/1969	4,086	6.7	760.0
Nine Mile Point Nuclear Station, Unit 2	BWR	764	3/11/1988	4,049	4.3	753.1
North Anna Power Station, Unit 1	PWR	157	6/6/1978	1,737	9.1	868.5
North Anna Power Station, Unit 2	PWR	157	12/14/1980	See above (pool shared with Unit 1)		
Oconee Nuclear Station, Unit 1	PWR	177	7/15/1973	1,312	5.4	656.0
Oconee Nuclear Station, Unit 2	PWR	177	9/9/1974	See above (pool shared with Unit 1)		
Oconee Nuclear Station, Unit 3	PWR	177	12/16/1974	825	3.7	412.5
Oyster Creek Nuclear Generating Station, Unit 1	BWR	560	12/1/1969	3,035	4.4	564.5
Palisades Nuclear Plant	PWR	204	12/31/1971	892	3.4	446.0
Palo Verde Nuclear Generating Station, Unit 1	PWR	241	1/28/1986	1,329	4.5	664.5
Palo Verde Nuclear Generating Station, Unit 2	PWR	241	9/19/1986	1,329	4.5	664.5
Palo Verde Nuclear Generating Station, Unit 3	PWR	241	1/8/1988	1,329	4.5	664.5
Peach Bottom Atomic Power Station, Unit 2	BWR	764	7/5/1974	3,819	4.0	710.3
Peach Bottom Atomic Power Station, Unit 3	BWR	764	12/23/1974	3,819	4.0	710.3
Perry Nuclear Power Plant, Unit 1	BWR	748	11/18/1987	4,020	4.4	747.7
Pilgrim Nuclear Power Station	BWR	580	12/1/1972	3,859	5.7	717.8
Point Beach Nuclear Plant, Unit 1	PWR	121	12/21/1970	1,502	10.4	751.0
Point Beach Nuclear Plant, Unit 2	PWR	121	10/1/1972	See above (pool shared with Unit 1)		
Prairie Island Nuclear Generating Plant, Unit 1	PWR	121	12/16/1973	1,386	9.5	693.0
Prairie Island Nuclear Generating Plant, Unit 2	PWR	121	12/21/1974	See above (pool shared with Unit 1)		
Quad Cities Nuclear Power Station, Unit 1	BWR	724	2/18/1973	3,657	4.1	680.2
Quad Cities Nuclear Power Station, Unit 2	BWR	724	3/10/1973	3,897	4.4	724.8

Table G-1. Capacity of Spent Fuel Pools for Operating Nuclear Power Reactors (cont'd)

Operating Reactors	Reactor Type	Core Size (assemblies)	Commercial Operation Start Date	Pool Capacity (assemblies)	Pool Capacity (cores)	Estimated Pool Capacity ^(b) (MTU)
River Bend Station, Unit 1	BWR	624	6/16/1986	3,104	4.0	577.3
R.E. Ginna Nuclear Power Plant	PWR	121	7/1/1970	1,321	9.9	660.5
St. Lucie Plant, Unit 1	PWR	217	12/21/1976	1,706	6.9	853.0
St. Lucie Plant, Unit 2	PWR	217	8/8/1983	1,716	6.9	858.0
Salem Nuclear Generating Station, Unit 1	PWR	193	6/30/1977	1,632	7.5	816.0
Salem Nuclear Generating Station, Unit 2	PWR	193	10/13/1981	1,632	7.5	816.0
Seabrook Station, Unit 1	PWR	193	8/19/1990	1,236	5.4	618.0
Sequoyah Nuclear Plant, Unit 1	PWR	193	7/1/1981	2,091	9.8	1,045.5
Sequoyah Nuclear Plant, Unit 2	PWR	193	6/1/1982	See above (pool shared with Unit 1)		
Shearon Harris Nuclear Power Plant, Unit 1 ^(f)	PWR	157	5/2/1987	1,128	6.2	564.0
South Texas Project, Unit 1	PWR	193	8/25/1988	1,969	9.2	984.5
South Texas Project, Unit 2	PWR	193	6/19/1989	1,969	9.2	984.5
Surry Nuclear Power Station, Unit 1	PWR	157	12/22/1972	1,044	4.6	522.0
Surry Nuclear Power Station, Unit 2	PWR	157	5/1/1973	See above (pool shared with Unit 1)		
Susquehanna Steam Electric Station, Unit 1	BWR	764	6/8/1983	2,840	2.7	528.2
Susquehanna Steam Electric Station, Unit 2	BWR	764	2/12/1985	2,840	2.7	528.2
Three Mile Island Nuclear Station, Unit 1	PWR	177	9/2/1974	1,062	5.0	531.0
Turkey Point Nuclear Generating Station, Unit 3	PWR	157	12/14/1972	1,535	8.8	767.5
Turkey Point Nuclear Generating Station, Unit 4	PWR	157	9/7/1973	1,535	8.8	767.5
Vermont Yankee Nuclear Power Plant, Unit 1 ^(g)	BWR	368	11/30/1972	3,353	8.1	623.7
Virgil C. Summer Nuclear Station, Unit 1	PWR	157	1/1/1984	1,712	9.9	856.0
Vogtle Electric Generating Plant, Unit 1	PWR	193	6/1/1987	1,476	6.6	738.0
Vogtle Electric Generating Plant, Unit 2	PWR	193	5/20/1989	2,098	9.9	1,049.0
Waterford Steam Electric Station, Unit 3	PWR	217	9/24/1985	1,849	7.5	924.5

Table G-1. Capacity of Spent Fuel Pools for Operating Nuclear Power Reactors (cont'd)

Operating Reactors	Reactor Type	Core Size (assemblies)	Commercial Operation Start Date	Pool Capacity (assemblies)	Pool Capacity (cores)	Estimated
						Pool Capacity ^(a) (cores)
Watts Bar Nuclear Plant, Unit 1 ^(h)	PWR	193	5/27/1996	1,386	6.2	693.0
Wolf Creek Generating Station, Unit 1	PWR	193	9/3/1985	2,363	11.2	1,181.5

Source: Reactor operating licenses, available through the NRC's website at <http://www.nrc.gov/reactors/operating/list-power-reactor-units.html> (NRC 2014a).

(a) Represents capacity with full core offload maintained; pool capacity (cores) is derived by subtracting one core's worth of assemblies from pool capacity (assemblies) and then dividing that number by core size (assemblies).

(b) Pool capacity (MTU) is derived by multiplying 500 kg (or 0.5 metric ton) per assembly for a PWR or 186 kg (0.186 metric ton) per assembly for a BWR by the number of assemblies in pool capacity.

(c) Plus 160 PWR assemblies.

(d) Plus 144 PWR assemblies.

(e) Brunswick Steam Electric Plant and H.B. Robinson Steam Electric Plant shipped to Shearon Harris Nuclear Power Plant.

(f) Shearon Harris is licensed to store 2,541 BWR fuel assemblies from other plants, in addition to its 1,128 PWR fuel assemblies.

(g) Entergy Nuclear Operations has certified that power operations will permanently cease in the fourth quarter of 2014 (Entergy 2013).

(h) Watts Bar Nuclear Plant, Unit 2 is under construction and would share the pool with Unit 1.

Table G-2. Capacity of Spent Fuel Pools for Power Reactors Under Construction

Operating Reactors	Reactor Type	Core Size (assemblies)	Commercial Operation Start Date	Pool Capacity (assemblies)	Pool Capacity (cores)	Estimated Pool Capacity ^(b) (MTU)
Vogtle Electric Generating Plant, Unit 3	PWR	157	future	889	4.7	444.5
Vogtle Electric Generating Plant, Unit 4	PWR	157	future	889	4.7	444.5
Virgil C. Summer Nuclear Station, Unit 2	PWR	157	future	889	4.7	444.5
Virgil C. Summer Nuclear Station, Unit 3	PWR	157	future	889	4.7	444.5
Watts Bar Nuclear Plant, Unit 2 ^(c)	PWR	193	future	Would share pool with Unit 1 (see Table G-1)		

Sources: Combined licenses for Vogtle Electric Generating Plant and Virgil C. Summer Nuclear Station are available through the NRC's website at <http://www.nrc.gov/reactors/new-reactors/vogtle.html> and <http://www.nrc.gov/reactors/new-reactors/col/summer.html>, respectively (NRC 2014b). For Watts Bar, information can be found at <http://www.nrc.gov/info-finder/reactor/wb/watts-bar.html> (NRC 2014c).

(a) Represents capacity with full core offload maintained; pool capacity (cores) is derived by subtracting one core's worth of assemblies from pool capacity (assemblies) and then dividing that number by core size (assemblies).

(b) Pool capacity (MTU) is derived by multiplying 500 kg (or 0.5 metric ton) per assembly (assumed for PWR) by the number of assemblies in pool capacity (889).

(c) The NRC staff anticipates a decision on the application for an operating license in 2015.

Table G-3. Capacity of In-Use Spent Fuel Pools for Decommissioning Facilities

Operating Reactors	Reactor Type	Core Size (assemblies)	Commercial Operation Start Date	Pool Capacity (assemblies)	Pool Capacity (cores)	Est. Pool Capacity ^(b) (MTU)
Crystal River Nuclear Generating Plant, Unit 3	PWR	177	3/13/1977	1,474	7.3	737.0
Kewaunee Power Station	PWR	121	6/16/1974	1,205	9.0	602.5
Millstone Power Station, Unit 1	BWR	580	12/28/1970	2,959	4.1	550.4
San Onofre Nuclear Generating Station, Unit 2	PWR	217	8/8/1983	1,542	6.1	771.0
San Onofre Nuclear Generating Station, Unit 3	PWR	217	4/1/1984	1,542	6.1	771.0
Zion Nuclear Power Station, Unit 1	PWR	193	10/19/1973	3,012	14.6	1506.0
Zion Nuclear Power Station, Unit 2	PWR	193	11/14/1973	See above (pool shared with Unit 1)		

Sources: <http://www.nrc.gov/info-finder/decommissioning/power-reactor> (NRC 2014d); Duke 2013 (for Crystal River Nuclear Generating Plant); Dominion 2013 (for Kewaunee Power Station); Dominion 2011 (for Millstone Power Station); SCE 2013 (for San Onofre Nuclear Generating Station); and Commonwealth Edison 1993, 1998 (for Zion Nuclear Power Station).

(a) Represents capacity with full core offload maintained; pool capacity (cores) is derived by subtracting one core's worth of assemblies from pool capacity (assemblies) and then dividing that number by core size (assemblies).

(b) Pool capacity (MTU) is derived by multiplying 500 kg (or 0.5 metric ton) per assembly for a PWR or 186 kg (0.186 metric ton) per assembly for a BWR by the number of assemblies in pool capacity.

Table G-4. ISFSIs Operating Under Part 72 General License

Site	Storage System			Approved for High-Burnup Spent Fuel? ^(b)
	Initial Storage Date	Vendor	Design	
Arkansas Nuclear One	12/17/1996	BNG Fuel Solutions	VSC-24	No
Arkansas Nuclear One	12/17/1996	Holtec International	HI-STORM	No
Big Rock Point Nuclear Power Plant	11/18/2002	BNG Fuel Solutions	W-150	No
Braidwood Station	11/23/2011	Holtec International	HI-STORM 100	No
Browns Ferry Nuclear Plant	8/21/2005	Holtec International	HI-STORM 100S	No
Brunswick Steam Electric Plant ^(c)	10/28/2010	Transnuclear, Inc.	NUHOMS	Yes (T, S)
Byron Station	9/9/2010	Holtec International	HI-STORM 100S	No
Catawba Nuclear Station	7/30/2007	NAC International, Inc.	NAC-UIMS	Yes (T, S)
Catawba Nuclear Station	5/7/2013	NAC International, Inc.	MAGNASTOR	Under Review
Columbia Generating Station	9/2/2002	Holtec International	HI-STORM 100S	No
Comanche Peak Steam Electric Station	2/28/2012	Holtec International	HI-STORM 100	No
Donald C. Cook Nuclear Power Plant	8/1/2012	Holtec International	HI-STORM 100	No
Cooper Nuclear Station	10/21/2010	Transnuclear, Inc.	NUHOMS	Yes (T)
Davis-Besse Nuclear Power Station	1/1/1996	Transnuclear, Inc.	NUHOMS	No
Dresden Nuclear Power Station	7/10/2000	Holtec International	HI-STAR 100	No
Dresden Nuclear Power Station	7/10/2000	Holtec International	HI-STORM 100	No
Duane Arnold Energy Center	9/1/2003	Transnuclear, Inc.	NUHOMS	Yes (T)
Fort Calhoun Station	7/29/2006	Transnuclear, Inc.	NUHOMS	Yes (T)
Grand Gulf Nuclear Station	11/18/2006	Holtec International	HI-STORM 100S	No
Haddam Neck	5/21/2004	NAC International, Inc.	NAC-MPC	No
Edwin I. Hatch Nuclear Plant	7/6/2000	Holtec International	HI-STAR 100	No

Table G-4. ISFSIs Operating Under Part 72 General License (cont'd)

Site	Storage System			Approved for High-Burnup Spent Fuel? ^(b)	
	Initial Storage Date	Vendor	Design		Associated Transportation Package ^(a)
Edwin I. Hatch Nuclear Plant	7/6/2000	Holtec International	HI-STORM 100/S	71-9261	No
Edwin I. Hatch Nuclear Plant	7/6/2000	Transnuclear, Inc.	NUHOMS	71-9302	Yes (T)
H.B. Robinson Steam Electric Plant	8/11/2005	Transnuclear, Inc.	NUHOMS	71-9302	Yes (T, S)
Hope Creek Generating Station	11/10/2006	Holtec International	HI-STORM 100	71-9261	No
Indian Point Nuclear Generating Plant	1/11/2008	Holtec International	HI-STORM 100	71-9261	No
James A. FitzPatrick Nuclear Power Plant	4/25/2002	Holtec International	HI-STORM 100/S	71-9261	No
Joseph M. Farley Nuclear Plant	8/25/2005	Holtec International	HI-STORM 100S	71-9261	No
Kewaunee Power Station	8/22/2009	Transnuclear, Inc.	NUHOMS	71-9302	Yes (T)
La Crosse Boiling Water Reactor ^(c)	7/12/2012	NAC International, Inc.	NAC-MPC	71-9235	No
LaSalle County Station	11/1/2010	Holtec International	HI-STORM 100S	71-9261	No
Limerick Generating Station	8/1/2008	Transnuclear, Inc.	NUHOMS	71-9302	Yes (T, S)
Maine Yankee	8/24/2002	NAC International, Inc.	NAC-UMS	71-9270	Yes (T, S)
McGuire Nuclear Station	8/1/2013	NAC International, Inc.	MAGNASTOR	pending (71-9356)	Yes (T, S)
McGuire Nuclear Station	2/1/2001	Transnuclear, Inc.	TN Metal Casks	None	No
McGuire Nuclear Station	2/27/2001	NAC International, Inc.	NAC-UMS	71-9270	Yes (T, S)
Millstone Power Station	2/15/2005	Transnuclear, Inc.	NUHOMS	71-9302	Yes (T)
Monticello Nuclear Generating Plant	9/17/2008	Transnuclear, Inc.	NUHOMS	71-9302	Yes (T, S)
Nine Mile Point Nuclear Station	9/8/2012	Transnuclear, Inc.	NUHOMS	71-9302	Yes (T)
North Anna Power Station	3/10/2008	Transnuclear, Inc.	TN Metal Casks	None	No
North Anna Power Station	3/10/2008	Transnuclear, Inc.	NUHOMS-HD	71-9302	Yes (T, S)
Oconee Nuclear Station	3/5/1999	Transnuclear, Inc.	NUHOMS	None	Yes (S)
Oyster Creek Nuclear Generating Station	12/20/2001	Transnuclear, Inc.	NUHOMS	71-9302	Yes (T, S)

Table G-4. ISFSIs Operating Under Part 72 General License (cont'd)

Site	Storage System			Approved for High-Burnup Spent Fuel? ^(b)
	Initial Storage Date	Vendor	Design	
Station				
Palisades Nuclear Plant	5/11/1993	EnergySolutions	VSC-24	No
Palisades Nuclear Plant	5/11/1993	Transnuclear, Inc.	NUHOMS	Yes (T, S)
Palo Verde Nuclear Generating Station	3/15/2003	NAC International, Inc.	NAC-UMS	Yes (T, S)
Peach Bottom Atomic Power Station	6/12/2000	Transnuclear, Inc.	TN Metal Casks	No
Perry Nuclear Power Plant ^(c)	9/29/2012	Holtec International	HI-STORM 100	No
Point Beach Nuclear Plant	5/26/1996	EnergySolutions	VSC-24	No
Point Beach Nuclear Plant	5/26/1996	Transnuclear, Inc.	NUHOMS	Yes (T)
Quad Cities Nuclear Power Station	12/2/2005	Holtec International	HI-STORM 100S	No
R.E. Ginna Nuclear Power Plant ^(c)	8/23/2010	Transnuclear, Inc.	NUHOMS	Yes (T)
River Bend Station	12/29/2005	Holtec International	HI-STORM 100S	No
St. Lucie Plant	3/21/2008	Transnuclear, Inc.	NUHOMS-HD	Yes (T, S)
Salem Nuclear Generating Station	11/10/2006	Holtec International	HI-STORM 100	No
San Onofre Nuclear Generating Station	10/3/2003	Transnuclear, Inc.	NUHOMS	No
Seabrook Station	8/7/2008	Transnuclear, Inc.	NUHOMS-HD	Yes (T)
Sequoyah Nuclear Plant	7/1/2004	Holtec International	HI-STORM 100/S	Yes (T,S)
Surry Nuclear Power Station	8/6/2007	Transnuclear, Inc.	NUHOMS-HD	No
Susquehanna Steam Electric Station	10/18/1999	Transnuclear, Inc.	NUHOMS	Yes (T, S)
Turkey Point Nuclear Generating Station	7/29/2011	Transnuclear, Inc.	NUHOMS-HD	Yes (T, S)
Vermont Yankee Nuclear Power Plant	5/29/2008	Holtec International	HI-STORM 100	No
Waterford Steam Electric Station	11/8/2011	Holtec International	HI-STORM 100	No

Table G-4. ISFSIs Operating Under Part 72 General License (cont'd)

Site	Initial Storage Date	Storage System		Associated Transportation Package ^(a)	Approved for High-Burnup Spent Fuel? ^(b)
		Vendor	Design		
Yankee Rowe	6/26/2002	NAC International, Inc.	NAC-MPC	71-9235	No
Vogtle Electric Generating Plant	10/26/2013	Holtec International	HI-STORM 100S	71-9261	No
Zion Nuclear Power Station	1/9/2014	NAC International, Inc.	MAGNASTOR	pending (71-9356)	Yes (T, S)

Sources: NRC 2013a; UxC 2013; NRC 2013b; Greene et al. 2013; storage and transportation certificates of compliance available in the NRC's Agencywide Documents Access and Management System (ADAMS).

(a) A docket number in this column indicates that a storage system is in use at the site that has an associated transportation package certificate. Other systems may or may not be in use at the site that do not have associated transportation package certificates. Certified transportation packages could require additional NRC review under the NRC's transportation requirements in 10 CFR Part 71 before the packages may be used for transportation. Whether a transportation package requires additional NRC review is dependent on whether modifications to the design or the construction of the storage system have occurred since the NRC issued the initial certificates of compliance for storage under 10 CFR Part 72 and for transportation under 10 CFR Part 71. Additional NRC review of transportation packages or contents could also be required if so specified in the transportation certificate of compliance.

(b) An "S" in this column indicates that the storage system is approved for use with high-burnup fuel and a "T" indicates that the transportation package is approved for use with high-burnup fuel. A "No" in this column indicates that neither the storage system nor the transportation package has been approved for use with high-burnup fuel. This column does not indicate whether high-burnup fuel is actually in storage at the site.

(c) Initial storage dates for Brunswick Steam Electric Plant (Progress Energy 2010), R.E. Ginna Nuclear Power Plant (CENG 2010), La Crosse Boiling Water Reactor (Dairyland 2012), and Perry Nuclear Power Plant (FirstEnergy 2012) were obtained from licensee letters.

Table G-5. ISFSIs Operating Under Part 72 Specific Licenses

Site	License No.	Expiration		Storage System			Approved for High-Burnup Spent Fuel? ^(b)	
		Start Date	Initial License Renewed License	Vendor	Design	Associated Transportation Package ^(a)		
Calvert Cliffs Nuclear Power Plant	SNM-2505	11/25/1992	2012	NA	Transnuclear, Inc.	NUHOMS	None	No
Diablo Canyon Nuclear Power Plant	SNM-2511	3/22/2004	2024	NA	Holtec International	HI-STORM 100	71-9261	No
Fort St. Vrain	SNM-2504	11/4/1991	2011	2031	FW Energy Applications, Inc. or the U.S. Department of Energy	Foster Wheeler	None	Yes (S)
H.B. Robinson Steam Electric Plant, Unit 2	SNM-2502	8/13/1986	2006	2046	Transnuclear, Inc.	NUHOMS	71-9302	Yes (T, S)
Humboldt Bay	SNM-2514	11/30/2005	2025	NA	Holtec International	HI-STAR HB	71-9261	No
Idaho National Laboratory TMI-2 Fuel Debris	SNM-2508	3/19/1999	2019	NA	Transnuclear, Inc.	NUHOMS	None	No
Idaho Spent Fuel Facility ^(c)	SNM-2512	11/30/2004	2024	NA	Licensee: DOE (formerly Foster Wheeler Environmental Corporation)	Concrete Vault	None	No
Morris Operation (GE Hitachi)	SNM-2500	5/4/1982	2002	2022	NA	Wet storage	NA	No
North Anna Power Station Units 1 and 2	SNM-2507	6/30/1998	2018	NA	Transnuclear, Inc.	NUHOMS-HD	71-9302	Yes (T, S)
Oconee Nuclear Station, Units 1, 2, and 3	SNM-2503	1/29/1990	2010	2050	Transnuclear, Inc.	NUHOMS	None	Yes (S)

Table G-5. ISFSIs Operating Under Part 72 Specific Licenses (cont'd)

Site	License No.	Start Date	Expiration		Storage System			Approved for High-Burnup Spent Fuel? ^(b)
			Initial License	Renewed License	Vendor	Design	Associated Transportation Package ^(a)	
Prairie Island Nuclear Generating Plant	SNM-2506	10/19/1993	2013	NA	Transnuclear, Inc.	TN-40	71-9313	Yes (S)
Private Fuel Storage Facility ^(c)	SNM-2513	2/21/2006	2026	NA	Holtec International	HI-STORM 100	71-9261	No
Rancho Seco	SNM-2510	6/30/2000	2020	NA	Transnuclear, Inc.	NUHOMS	71-9302	Yes (T)
Surry Nuclear Power Station	SNM-2501	7/2/1986	2006	2046	General Nuclear	Castor	None	No
Surry Nuclear Power Station	SNM-2501	7/2/1986	2006	2046	NAC International, Inc.	NAC-I28	None	No
Surry Nuclear Power Station	SNM-2501	7/2/1986	2006	2046	Transnuclear, Inc.	NUHOMS-HD	71-9302	Yes (T, S)
Surry Nuclear Power Station	SNM-2501	7/2/1986	2006	2046	Westinghouse, Inc.	MC-10	None	No
Trojan	SNM-2509	3/31/1999	2019	NA	Holtec International	HI-STORM 100	71-9261	No

Sources: NRC 2013a; UxC 2013; NRC 2013b; Greene et al. 2013; storage and transportation certificates of compliance available in ADAMS; some information for Idaho National Laboratory TMI-2, the Private Fuel Storage facility, and Morris Operation obtained from additional sources: see DOE 2007 (for Idaho TMI-2 facility), NRC 2006 (for Private Fuel Storage), and NRC 2004 (for Morris).

(a) A docket number in this column indicates that a storage system is in use at the site that has an associated transportation package certificate. Other systems may or may not be in use at the site that do not have associated transportation package certificates. Certified transportation packages could require additional NRC review under the NRC's transportation requirements in 10 CFR Part 71 before the packages may be used for transportation. Whether a transportation package requires additional NRC review is dependent on whether modifications to the design or the construction of the storage system have occurred since the NRC issued the initial certificates of compliance for storage under Part 72 and for transportation under Part 71. Additional NRC review of transportation packages or contents could also be required if so specified in the transportation certificate of compliance.

(b) An "S" in this column indicates that the storage system is approved for use with high-burnup fuel and a "T" indicates that the transportation package is approved for use with high-burnup fuel. A "No" indicates that neither the storage system nor the transportation package has been approved for use with high-burnup fuel. This column does not indicate whether high-burnup fuel is actually in storage at the site.

(c) Private Fuel Storage Facility and Idaho Spent Fuel Facility were licensed but have not been constructed.

HTGR = high-temperature gas-cooled reactor; NA = Not applicable.

References

10 CFR Part 50. *Code of Federal Regulations*, Title 10, *Energy*, Part 50, “Domestic Licensing of Production and Utilization Facilities.” Washington, D.C.

10 CFR Part 52. *Code of Federal Regulations*, Title 10, *Energy*, Part 52, “Licenses, Certifications, and Approvals for Nuclear Power Plants.” Washington, D.C.

10 CFR Part 72. *Code of Federal Regulations*, Title 10, *Energy*, Part 72, “Licensing Requirements for the Independent Storage of Spent Nuclear Fuel, High-Level Radioactive Waste, and Reactor-Related Greater than Class C Waste.” Washington, D.C.

CENG. 2010. Letter from T.L. Harding to NRC, dated September 16, 2010, regarding “General License 30-day Cask Registration Notification.” Ontario, New York. Accession No. ML102670066.

Commonwealth Edison. 1993. *Zion Station Updated Final Safety Analysis Report*. Volume 3, Chicago, Illinois. Accession No. ML081370016.

Commonwealth Edison. 1998. Letter from R.S. Starkey to NRC, dated November 10, 1998, regarding “Submittal of Defueled Safety Analysis Report.” Chicago, Illinois. Accession No. ML12300A258.

Dairyland (Dairyland Power Cooperative). 2012. Letter from J.B. McRill to NRC, dated July 12, 2012, regarding “Registration of Spent Fuel Dry Storage Cask in Use.” LAC-14245, Genoa, Wisconsin. Accession No. ML12199A069.

DOE (U.S. Department of Energy). 2007. Letter from B.J. Davis to NRC, dated March 15, 2007, regarding “Submittal of Three Mile Island Unit 2 Independent Spent Fuel Storage Installation (TMI-2 ISFSI) Update Reports (Docket 72-20).” EM-FMDP-07-008, Idaho Falls, Idaho. Accession No. ML070820547.

Dominion (Dominion Energy Kewaunee, Inc.). 2013. Letter from D.G. Stoddard to NRC, dated May 14, 2013, regarding “Dominion Energy Kewaunee, Inc., Kewaunee Power Station Certification of Permanent Removal of Fuel from Reactor Vessel.” Serial No. 13-293, Glen Allen, Virginia. Accession No. ML13135A209.

Dominion (Dominion Nuclear Connecticut, Inc.). 2011. *Millstone Power Station Unit 1 Defueled Safety Analysis Report*. Revision 8.0, Waterford, Connecticut. Accession No. ML11231A618.

Duke (Duke Energy). 2013. Letter from J.A. Franke to NRC, dated February 20, 2013, regarding “Crystal River Unit 3—Certification of Permanent Cessation of Power Operations and that Fuel Has Been Permanently Removed from the Reactor.” 3F0213–07, Crystal River, Florida. Accession No. ML13056A005.

Entergy (Entergy Nuclear Operations, Inc.). 2013. Letter from M. Perito to NRC, dated September 23, 2013, regarding “Notification of Permanent Cessation of Power Operations.” White Plains, New York. Accession No. ML13273A204.

FirstEnergy (First Energy Nuclear Operating Company). 2012. Letter from H.D. Hanson, Jr. to NRC, dated October 23, 2012, regarding “Spent Fuel Storage Cask Registration.” L–12–383, Perry, Ohio. Accession No. ML12310A088.

Greene, S.R., J.S. Medford, and S.A. Macy. 2013. *Storage and Transport Cask Data for Used Commercial Nuclear Fuel—2013 U.S. Edition*. ATI-TR-13047, Knoxville, Tennessee. Available at <http://curie.ornl.gov/content/storage-and-transport-cask-data-used-commercial-nuclear-fuel-2013-us-edition-0>.

National Environmental Policy Act of 1969 (NEPA), as amended. 42 USC 4321 *et seq.*

NRC (U.S. Nuclear Regulatory Commission). 2004. Letter from J. Monninger to J.E. Ellis, dated December 21, 2004, regarding “Issuance of Renewed Materials License No. SNM–2500, Morris Operation Independent Spent Fuel Storage Operation.” TAC No. L23091, Washington, D.C. Accession No. ML043630433.

NRC (U.S. Nuclear Regulatory Commission). 2006. Letter from W.H. Ruland to J.D. Parkyn, dated February 21, 2006, regarding “Issuance of Materials License No. SNM–2513 for the Private Fuel Storage Facility (TAC No. L23821).” Washington, D.C. Accession No. ML060450350.

NRC (U.S. Nuclear Regulatory Commission). 2013a. *2013-2014 Information Digest*. NUREG–1350, Volume 25, Washington, D.C. Accession No. ML13241A207.

NRC (U.S. Nuclear Regulatory Commission). 2013b. *Directory of Certificates of Compliance for Radioactive Materials Packages*. NUREG-0383, Volume 2, Revision 28, Washington, D.C. Accession No. ML13309A031.

NRC (U.S. Nuclear Regulatory Commission). 2014a. “Operating Reactors.” Washington, D.C. Available at <http://www.nrc.gov/reactors/operating/list-power-reactor-units.html>.

NRC (U.S. Nuclear Regulatory Commission). 2014b. “Combined License Applications for New Reactors.” Washington, D.C. Available at <http://www.nrc.gov/reactors/new-reactors/col.html>.

Appendix G

NRC (U.S. Nuclear Regulatory Commission). 2014c. "Watts Bar Unit 2 Reactivation." Washington, D.C. Available at <http://www.nrc.gov/info-finder/reactor/wb/watts-bar.html>.

NRC (U.S. Nuclear Regulatory Commission). 2014d. "Power Reactor Sites Undergoing Decommissioning." Washington, D.C. Available at <http://www.nrc.gov/info-finder/decommissioning/>.

Progress Energy. 2010. Letter from P.N. Mentel to NRC, dated November 18, 2010, regarding "Registration and Use of Casks to Store Spent Fuel and System Thermal Performance Assessment." BSEP 10-0135, Southport, North Carolina. Accession No. ML103330167.

SCE (Southern California Edison). 2013. Letter from P. Dietrich to NRC, dated June 12, 2013, regarding "Certification of Permanent Cessation of Power Operations, San Onofre Nuclear Generating Station Units 2 and 3." San Clemente, California. Accession No. ML131640201.

UxC (Ux Consulting Company, LLC). 2013. "Over 1700 Dry Storage Systems Deployed in the US." *StoreFUEL* 14(173):14-173, Roswell, Georgia.

Appendix H

Estimated Costs of Alternatives

Appendix H

Estimated Costs of Alternatives

This appendix provides the cost information upon which the U.S. Nuclear Regulatory Commission (NRC) bases the cost portion of its costs and benefits analysis in Chapter 7 of this *Generic Environmental Impact Statement for Continued Storage of Spent Nuclear Fuel* (GEIS). Tables H-1 through H-3 provide the estimated costs of site-specific licensing reviews for new reactors, reactor license renewals, and independent spent fuel storage installations (ISFSI), respectively, which are applicable to the NRC's potential options in case of no action. Table H-4 provides estimated costs for generic elements of the proposed action, as well as the NRC's potential options in case of no action, including costs for development of the GEIS, rulemaking, and a policy statement, as applicable. Finally, Table H-5 provides the total estimated costs for the proposed action and the NRC's options in case of no action.

Table H-1. Estimated Site-Specific Costs for New Reactor Reviews

Cost per Activity^(a)		NRC Cost	Licensee Cost^(b)	Total Cost^(c)	
	First review	\$1,650,000	\$1,650,000	\$3,290,000	
	Existing review with supplement	\$981,000	\$981,000	\$1,960,000	
	New review	\$49,800	\$49,800	\$99,600	
	Title 10 of the Code of Federal Regulations (CFR) Part 50 review with supplement	\$232,000	\$232,000	\$465,000	
Year	Activity^(d)	Number	Constant 2014	3% Discount	7% Discount
2015	First review	1	\$3,290,000	\$3,200,000	\$3,080,000
2015	Existing review with supplement	2	\$3,930,000	\$3,810,000	\$3,670,000
2015	10 CFR Part 50 review with supplement	1	\$465,000	\$451,000	\$434,000
2016	Existing review with supplement	3	\$5,890,000	\$5,550,000	\$5,140,000
2017	Existing review with supplement	2	\$3,930,000	\$3,590,000	\$3,200,000
2018	New review	2	\$199,000	\$177,000	\$152,000
Sum^(e)			\$17,700,000	\$16,800,000	\$15,700,000

(a) As described in Chapter 7, the NRC estimates that, for new reactor reviews under 10 CFR Part 52, the first site-specific review of continued storage in a new reactor environmental impact statement (EIS) would require approximately 3.9 full-time equivalents (FTE) for NRC and \$1 million in contractor support. The NRC estimates that subsequent site-specific reviews that require supplementation of existing EISs require approximately 2.9 FTE for NRC, or \$481,000, and \$500,000 in contract support. The NRC estimates that a review of the environmental impacts of continued storage for a new operating license under 10 CFR Part 50 will require 1.4 FTE, or \$232,000.

(b) The NRC assumes that licensees incur costs that are equal to those incurred by the NRC, so the total cost is double the NRC's costs.

(c) Because of rounding, some costs may not appear to sum correctly.

(d) The NRC assumes that Levy, South Texas Project (Units 3 and 4), Comanche Peak (Units 3 and 4), Calvert Cliffs, Fermi (Unit 3), North Anna, Lee, and the PSE&G Power, LLC/PSE&G Nuclear, LLC Early Site Permit EISs all will require supplementation. One of these reviews will be the first review, and the others are labeled as existing reviews with supplements. Watts Bar 2 is the 10 CFR Part 50 review with supplementation. The NRC treats Turkey Point and Bell Bend as new reviews because the NRC is not likely to issue a draft EIS for either project by the end of fiscal year 2014; the NRC assumes that the environmental impacts of continued storage will be addressed within a normal review schedule for those projects.

Table H-2. Estimated Site-Specific Costs for Reactor License Renewals

Cost per Activity ^(a)		NRC Cost	Licensee Cost ^(b)	Total Cost ^(c)	
Year	Activity ^(d)	Number	Constant 2014	3% Discount	7% Discount
	First review		\$415,000	\$830,000	\$830,000
	Existing review with supplement		\$232,000	\$465,000	\$465,000
	Existing review without supplement		\$183,000	\$365,000	\$365,000
	New or subsequent renewal review		\$49,800	\$99,600	\$99,600
2015	First review	1	\$830,000	\$806,000	\$776,000
2015	Existing review with supplement	2	\$930,000	\$903,000	\$869,000
2016	Existing review with supplement	4	\$1,860,000	\$1,750,000	\$1,620,000
2017	Existing review without supplement	3	\$1,100,000	\$1,000,000	\$894,000
2017	Subsequent renewal	1	\$99,600	\$91,100	\$81,300
2018	Renewal review	4	\$398,000	\$354,000	\$304,000
2018	Subsequent renewal	1	\$99,600	\$88,500	\$76,000
2019	Renewal review	3	\$299,000	\$258,000	\$213,000
2019	Subsequent renewal	1	\$99,600	\$85,900	\$71,000
2020	Renewal review	2	\$199,000	\$167,000	\$133,000
2020	Subsequent renewal	1	\$99,600	\$83,400	\$66,400
2021	Subsequent renewal	1	\$99,600	\$81,000	\$62,000
2022	Subsequent renewal	1	\$99,600	\$78,600	\$58,000
2023	Subsequent renewal	1	\$99,600	\$76,300	\$54,200
2024	Subsequent renewal	1	\$99,600	\$74,100	\$50,600
2025	Subsequent renewal	1	\$99,600	\$72,000	\$47,300
2026	Subsequent renewal	1	\$99,600	\$69,900	\$44,200
2027	Subsequent renewal	1	\$99,600	\$67,800	\$41,300
2028	Subsequent renewal	1	\$99,600	\$65,800	\$38,600
2029	Subsequent renewal	1	\$99,600	\$63,900	\$36,100
2030	Subsequent renewal	1	\$99,600	\$62,100	\$33,700
2031	Subsequent renewal	1	\$99,600	\$60,300	\$31,500
2032	Subsequent renewal	1	\$99,600	\$58,500	\$29,500

Table H-2. Estimated Site-Specific Costs for Reactor License Renewals (cont'd)

Year	Activity ^(d)	Number	Constant 2014	3% Discount	7% Discount
2033	Subsequent renewal	1	\$99,600	\$56,800	\$27,500
2034	Subsequent renewal	1	\$99,600	\$55,100	\$25,700
2035	Subsequent renewal	1	\$99,600	\$53,500	\$24,100
2036	Subsequent renewal	1	\$99,600	\$52,000	\$22,500
2037	Initial or subsequent renewal	1	\$99,600	\$50,500	\$21,000
2038	Initial or subsequent renewal	1	\$99,600	\$49,000	\$19,600
2039	Initial or subsequent renewal	1	\$99,600	\$47,600	\$18,400
2040	Initial or subsequent renewal	1	\$99,600	\$46,200	\$17,200
2041	Initial or subsequent renewal	1	\$99,600	\$44,800	\$16,000
2042	Initial or subsequent renewal	1	\$99,600	\$43,500	\$15,000
2043	Initial or subsequent renewal	1	\$99,600	\$42,300	\$14,000
2044	Initial or subsequent renewal	1	\$99,600	\$41,000	\$13,100
Sum^(c)			\$8,400,000	\$7,000,000	\$5,870,000

(a) As described in Chapter 7, the NRC assumes that the first review would require an estimated 2.5 FTE, or \$415,000. The NRC further assumes that some reviews would require supplementation of existing EISs, and these reviews would require approximately 1.4 FTE, or \$232,000.

Reviews that do not require supplementation would require approximately 1.1 FTE, or \$183,000. Reviews of future applications (those that have not yet been submitted) would require approximately 0.3 FTE, or \$49,800.

(b) The NRC assumes that licensees incur costs that are equal to those incurred by the NRC, so the total cost is double the NRC's costs.

(c) Due to rounding, some costs may not appear to sum correctly.

(d) The NRC assumes that South Texas Project (Units 1 and 2), Grand Gulf, Callaway, Limerick, Davis-Besse, Seabrook, and Indian Point would require supplementation given current project schedules. One of these reviews would be the first review. The NRC assumes that Sequoyah, Byron, and Braidwood will be existing reviews that do not require supplements by the end of fiscal year 2014. Diablo Canyon, Waterford, Fermi (Unit 2), Riverbend, La Salle, Perry, Clinton, one facility in the STARS (Strategic Teaming and Resource Sharing) Alliance, and Watts Bar 1 are labeled as new license renewal reviews because the NRC will be able to address the environmental impacts of continued storage within a normal review schedule for those projects. The NRC has not identified specific plants that will seek subsequent license renewals, but estimates that half of the existing reactor fleet will do so.

Table H-3. Estimated Site-Specific Costs for ISFSI Licensing

Cost per Activity ^(a)		NRC Cost	Licensee Cost ^(b)	Total Cost ^(c)	
	First renewal review	\$83,000	\$83,000	\$166,000	
	Renewal review	\$41,500	\$41,500	\$83,000	
Year	Activity ^(d)	Number	Constant 2014	3% Discount	7% Discount
2015	First renewal review	2	\$332,000	\$322,000	\$310,000
2018	Renewal review	1	\$83,000	\$73,700	\$63,300
2019	Renewal review	2	\$166,000	\$143,000	\$118,000
2020	Renewal review	1	\$83,000	\$69,500	\$55,300
2022	Renewal review	1	\$83,000	\$65,500	\$48,300
2024	Renewal review	1	\$83,000	\$61,800	\$42,200
2025	Renewal review	1	\$83,000	\$60,000	\$39,400
2026	Renewal review	2	\$166,000	\$116,000	\$73,700
2032	Renewal review	1	\$83,000	\$48,800	\$24,600
Sum^(c)			\$1,160,000	\$961,000	\$775,000

(a) As discussed in Chapter 7, the NRC estimates that approximately 0.5 FTE, or \$83,000, would be necessary to support site-specific consideration of continued storage in the first two ISFSI Environmental Assessments, both of which are currently under review. The NRC estimates that later ISFSI Environmental Assessments will require 0.25 FTE, or \$41,500.

(b) The NRC assumes that licensees incur costs that are equal to those incurred by the NRC, so the total cost is double the NRC's costs.

(c) Due to rounding, some costs may not appear to sum correctly.

(d) Activity dates are based on license expiration dates. Currently, two site-specific ISFSI license renewal applications, Calvert Cliffs and Prairie Island, are docketed at the NRC. Therefore, the NRC assumes that these reviews will be the first reviews. Other site-specific ISFSI licenses that will expire during the 30-year analysis period are North Anna (2018), Three Mile Island Unit 2 (2019), Trojan (2019), Rancho Seco (2020), GE Morris (2022), Diablo Canyon (2024), Idaho Spent Fuel Facility (2025), Humboldt Bay (2026), Private Fuel Storage (2026), and Fort St. Vrain (2032). Other facilities with site-specific ISFSIs do not require renewal by 2044. See Appendix G for more information on ISFSIs.

Table H-4. Estimated Costs of Generic Elements^(a)

GEIS Development (applies to proposed action and all options in case of no action except site-specific review)^(b)			
	FTE^(c)	Contractor	Total
Annual Cost	20.0	\$3,000,000	\$6,320,000
Year^(c)	Constant 2014		
2013 ^(e)	\$6,420,000		
2014	\$6,320,000		
Sum^(f)	\$12,700,000		
Rulemaking (applies to the Proposed Action)^(b)			
	FTE^(c)	Contractor	Total
Annual Cost	3.0	\$0	\$498,000
Year^(c)	Constant 2014		
2013 ^(e)	\$506,000		
2014	\$498,000		
Sum^(f)	\$1,000,000		
Policy Statement (Applies to the Policy Statement option)^(d)			
	FTE^(c)	Contractor	Total
Annual Cost	1.5	\$0	\$249,000
Year^(c)	Constant 2014	3% Discount	7% Discount
2015	\$249,000	\$242,000	\$233,000
2016	\$249,000	\$235,000	\$217,000
Sum^(f)	\$498,000	\$476,000	\$450,000

- (a) Generic elements are those portions of the alternatives that are not directly attributable to any site-specific review.
- (b) The NRC assumes that the effort necessary to develop the GEIS and rule occurs during fiscal years 2013 and 2014. While these costs are technically past, or "sunk," costs, the NRC includes them here to provide a complete and transparent analysis of the costs of the proposed action and NRC's potential options in the case of no action. Finally, because costs of the GEIS and rulemaking are not future costs, the NRC does not discount them in this analysis.
- (c) One FTE costs \$166,000 based on data from fiscal year 2013 (the most recent available data).
- (d) The NRC assumes that the effort necessary to develop the policy statement occurs during fiscal years 2015 and 2016 because, unlike the GEIS and rule, the NRC is not currently developing a policy statement.
- (e) The NRC uses the Bureau of Labor Statistics' (BLS) Consumer Price Index (CPI) to adjust 2013 costs to 2014 dollars (BLS 2014).
- (f) Due to rounding, some costs may not appear to sum correctly.

Table H-5. Total Estimated Costs of the Proposed Action and NRC's Options in Case of No Action

Proposed Action			
	Constant 2014		
GEIS	\$12,700,000		
Rulemaking	\$1,000,000		
Total Cost^(a)	\$13,700,000		
Site-Specific Review Option			
	Constant 2014	3% Discount	7% Discount
New reactor reviews	\$17,700,000	\$16,800,000	\$15,700,000
Reactor license renewal	\$8,400,000	\$7,000,000	\$5,870,000
ISFSI licensing	\$1,210,000	\$961,000	\$755,000
Total Cost^(a)	\$27,300,000	\$24,700,000	\$22,300,000
GEIS-Only Option			
<i>With No Cost Savings^(b)</i>	Constant 2014	3% Discount	7% Discount
New reactor reviews	\$17,700,000	\$16,800,000	\$15,600,000
Reactor license renewal	\$8,400,000	\$7,000,000	\$5,870,000
ISFSI licensing	\$1,160,000	\$961,000	\$775,000
GEIS development	\$12,700,000	\$12,700,000	\$12,700,000
Total Cost^(a)	\$40,000,000	\$37,500,000	\$35,100,000
<i>With 50% Cost Savings^(b)</i>	Constant 2014	3% Discount	7% Discount
New reactor reviews	\$8,850,000	\$8,390,000	\$7,840,000
Reactor license renewal	\$4,200,000	\$3,500,000	\$2,930,000
ISFSI licensing	\$581,000	\$481,000	\$388,000
GEIS development	\$12,700,000	\$12,700,000	\$12,700,000
Total Cost^(a)	\$26,400,000	\$25,100,000	\$23,900,000
Policy Statement Option			
<i>With No Cost Savings^(b)</i>	Constant 2014	3% Discount	7% Discount
New reactor reviews	\$17,700,000	\$16,800,000	\$15,700,000
Reactor license renewal	\$8,400,000	\$7,000,000	\$5,870,000
ISFSI licensing	\$1,160,000	\$961,000	\$775,000
GEIS development	\$12,700,000	\$12,700,000	\$12,700,000
Policy statement	\$498,000	\$476,000	\$450,000
Total Cost^(a)	\$40,500,000	\$38,000,000	\$35,500,000

Table H-5. Total Estimated Costs of the Proposed Action and NRC's Options in Case of No Action (cont'd)

Policy Statement Option, cont'd			
<i>50% Cost Savings^(b)</i>	Constant 2014	3% Discount	7% Discount
New reactor reviews	\$8,850,000	\$8,390,000	\$7,840,000
Reactor license renewal	\$4,200,000	\$3,500,000	\$2,930,000
ISFSI licensing	\$581,000	\$481,000	\$388,000
GEIS development	\$12,700,000	\$12,700,000	\$12,700,000
Policy statement	\$498,000	\$476,000	\$450,000
Total Cost^(a)	\$26,900,000	\$25,600,000	\$24,300,000

(a) Due to rounding, some costs may not appear to sum correctly. Costs for the proposed action are not discounted because the proposed action includes no future costs.

(b) The NRC estimates that staff and applicants may reduce their efforts by as much as 50% compared to the site-specific review option in both the GEIS-only and policy statement options. While effort will vary in each review, the reliance on the GEIS (and policy statement) to address generic issues related to continued storage will entirely resolve concerns for some issues, while other issues may require additional effort in resolving comments, addressing site-specific litigation, or establishing that the GEIS findings are applicable to a specific licensing proceeding.

References

10 CFR Part 50. *Code of Federal Regulations*, Title 10, *Energy*, Part 50, "Domestic Licensing of Production and Utilization Facilities." Washington, D.C.

10 CFR Part 52. *Code of Federal Regulations*, Title 10, *Energy*, Part 52, "Licenses, Certifications, and Approvals for Nuclear Power Plants." Washington, D.C.

10 CFR Part 72. *Code of Federal Regulations*, Title 10, *Energy*, Part 72, "Licensing Requirements for the Independent Storage of Spent Nuclear Fuel, High-Level Radioactive Waste, and Reactor-Related Greater than Class C Waste." Washington, D.C.

BLS (U.S. Bureau of Labor Statistics). 2014. CPI Detailed Report—Data for March 2014. Washington, D.C. Available at <http://www.bls.gov/cpi/cpid1403.pdf>.

Appendix I

High-Burnup Fuel

Appendix I

High-Burnup Fuel

During the public comment period on the draft Generic Environmental Impact Statement (GEIS), the U.S. Nuclear Regulatory Commission (NRC) held 13 public meetings in various locations throughout the United States. During those meetings, numerous questions, concerns, and comments were raised about the use of high-burnup fuel at nuclear power plants. As a result of the public's interest in this topic, the NRC developed this appendix to provide background information about high-burnup fuel. The material is presented in a question and answer format.

Q. What does “burnup” mean?

A. Burnup is a measure of the fraction of fissionable atoms that can undergo the fission process. It can be expressed as a measure of the time a fuel assembly stays in the reactor core and how much energy is extracted from that nuclear fuel assembly. Burnup is typically expressed in units of gigawatt-days per metric ton of the initial amount of the uranium in the fuel (GWd/MTU).

Q. What is high-burnup fuel and how does it differ from low-burnup fuel?

A. High-burnup fuel is typically defined as fuel with a burnup (a measure of the time a fuel assembly stays in the reactor core) greater than 45 GWd/MTU. Low-burnup fuel is defined as any fuel with a lower exposure than this value. Average fuel burnups have increased from around 35 GWd/MTU two decades ago, to over 45 GWd/MTU today. High-burnup fuel is thermally hotter and more radioactive than low-burnup fuel for a given cooling time. The difference in decay heat (a function of the fuel transferring heat to decrease its temperature over time) and radioactive source term depends on the difference in the fuel burnup (i.e., how long the fuel was being used in the reactor), the initial enrichment of the fuel, and the irradiation environment that the fuel was exposed to in the reactor. High-burnup fuel is typically cooled longer than low-burnup fuel before it can be placed into a dry storage system. How much longer depends on the difference in burnup, the specific dry storage system design, and the decay heat loading pattern of the fuel being used.

Q. How is mixed oxide (MOX) fuel different from uranium oxide (UOX) fuel?

A. As explained in Chapter 2 of the GEIS, mixed oxide (MOX) fuel is a type of nuclear reactor fuel that contains plutonium oxide mixed with either natural or depleted uranium oxide in the form of ceramic pellets. MOX fuel is not currently being produced in the United States;

however, an application is pending before the NRC for a MOX fuel fabrication facility. The mechanical design of MOX fuel is very similar to UOX fuel used in existing light water reactors. The planned MOX fuel also is intended for use in existing light water reactors in the United States. As with high-burnup UOX fuel, MOX fuel has higher thermal output and different radionuclide composition that needs to be considered in storage system design, operations, and maintenance.

Q. *How is high-burnup fuel licensed for reactor operations by the NRC?*

A. In reactor licensing and operations, the question of fuel burnup is addressed in reactor fuel system design safety reviews. The NRC uses the guidance in NUREG-0800 (Section 4.2, "Fuel System Design") (NRC 1987) when conducting these safety reviews. The reactor fuel system consists of numerous components including arrays (i.e., assemblies or bundles) of fuel rods, fuel pellets, insulator pellets, and tubular cladding. During reactor fuel system design safety reviews, the NRC evaluates the nuclear, thermal, mechanical, and materials design of the fuel system. These reviews provide assurance that (1) the fuel system is not damaged as a result of normal operations and anticipated operational occurrences, (2) fuel system damage is never so severe as to prevent control rod insertion when it is required, (3) the number of fuel rod failures is not underestimated for postulated accidents, and (4) coolability is always maintained. Fuel burnup is one of several fuel design operating limits established to ensure fuel reliability and acceptable performance during normal operations, anticipated operational occurrences, and postulated accidents. Fuel system design safety reviews consider the effects of burnup levels on the nuclear, thermal, mechanical, and materials design of the fuel system. For example, in a fuel system safety review, fuel rod failure criteria consider the high-burnup effects on overheating of fuel pellets. As a result, NRC acceptance of a reactor fuel design includes the fuel design's burnup operating limits. In addition, the NRC evaluates the environmental impacts of the agency's actions in accordance with the National Environmental Policy Act of 1969.

Q. *What happens to the high-burnup fuel after its use in a reactor?*

A. When any fuel is no longer suitable for use in the reactor, it is placed in a spent fuel pool where it is stored at least until it is cool enough that it can be transferred to dry storage. Data collected to date suggest very little or no degradation of the spent fuel in the pools as long as the water chemistry is maintained. The dry cask storage system receives a Certificate of Compliance from the NRC before it can be used for storing spent fuel. The behavior of the high-burnup fuel and the consequences of its potential degradation are thoroughly evaluated against standards for criticality, thermal, containment, and shielding safety along with the ability to safely retrieve it from storage before the NRC issues the Certificate of Compliance.

Q. Can high-burnup fuel be stored in dry cask storage systems?

A. As indicated above, when spent fuel is removed from a reactor, it is first stored in a spent fuel pool where it cools. After the spent fuel has cooled sufficiently so that its decay heat and radiation will not significantly damage the fuel itself or the storage components, the fuel can be transferred to a dry cask storage system. High-burnup fuel must be cooled longer than low-burnup fuel before it can be placed into a dry cask storage system. How much longer depends on the difference in burnup, the specific dry cask storage system design, and the decay heat loading pattern of the fuel being used. For example, for a 5.0 weight-percent enriched (in uranium-235) fuel assembly in one particular storage system, the required cooling time goes from 4.5, to 7, to 12 years, for fuel burnups of 35,000, 45, and 55 GWd/MTU, respectively. There are three types of dry cask storage systems for spent nuclear fuel (spent fuel):

- Storage-only systems that have not been approved for transportation.
- Dual-purpose systems that are designed for both storage and transport. Most of these systems have been approved for storage of high-burnup fuel only, but some also have been approved for transport of high-burnup fuel.
- Canister systems in which the canister may or may not be put into a new overpack for transport.

NRC regulations allow for the approval of spent fuel storage in dry casks for a period up to 40 years. While there is no indication that high-burnup fuel cannot be stored for the full 40 years, the NRC has only approved the storage of high-burnup fuel for 20 years. The 20-year period allows for earlier consideration of the increasing operational experience with and investigations of high-burnup fuel. A list of NRC-certified storage casks and transportation casks for high-burnup spent fuel is provided in Appendix G.

Q. How does dry cask storage of high-burnup fuel differ from low-burnup fuel?

A. Dry cask storage systems need to comply with NRC's regulations at 10 CFR Part 72. Based on research on the behavior of high-burnup spent fuel, the NRC has issued guidance for the conditions under which the fuel can be stored without expecting it to degrade in an unsafe manner (e.g., cladding temperature is limited to 400°C (752°F) for normal conditions of storage and short-term loading operations, the atmosphere is dry and inert). Cask design and loading configuration are used to meet requirements for the cask thermal load. Although high-burnup fuel most recently discharged from the reactor presents the largest thermal load, casks are typically loaded with spent fuel of different discharge times and potentially different burnup (i.e., loaded into different "zones" within the casks) so that the hottest assemblies are not all placed in a single cask. For example, the pressurized water reactor fuel qualification tables for NUHOMS-24PHB dry storage casks specify minimum

Appendix I

cooling times of 17 years (zone 1), 7.5 years (zone 2), and 6 years (zone 3) for spent fuel with 45 GWd/MTU burnup (based on 4 percent assembly average initial U-235 enrichment) compared to cooling times of 29.2 years (zone 1), 13.2 years (zone 2), and 7.6 years (zone 3) for spent fuel with 55 GWd/MTU burnup fuel (Transnuclear Inc. 2009). Whatever the thermal output or radiation flux of the spent fuel placed in the container, the loading must be consistent with the cask certificate and comply with the regulations.

The heat and radiation flux from any spent fuel assembly will vary as a function of initial enrichment, burnup, and time since the assembly was removed from the reactor. As a result of higher initial enrichment and longer service life in the reactor, high-burnup spent fuel has higher radioactivity and thermal output compared to low-burnup spent fuel.

In 2011, the International Atomic Energy Agency (IAEA) published a report that provides information on the thermal output and radiation flux for UOX fuel as a function of burnup and decay after discharge from the reactor (IAEA 2011). Table I-1 and Table I-2 provide values estimated from curves presented in the IAEA report for the thermal output and the neutron flux. Based on Table I-1, high-burnup fuel (55 GWd/MTU) after 15 years of decay has thermal output similar to 30 GWd/MTU fuel after 5 years of decay. High-burnup fuel also has increased neutron flux that could affect the thickness needed for the concrete overpack to reduce the neutron flux near the dry cask storage system. Based on Table I-2, high-burnup fuel (55 GWd/MTU) after 60 years of decay has a neutron flux similar to 30 GWd/MTU fuel after approximately 15 years of decay.

Table I-1. Dependence of decay heat (kW/MTU) on burnup and decay time for UOX fuel

Decay Time	Burnup 30 GWd/MTU	Burnup 45 GWd/MTU	Burnup 55 GWd/MTU	Burnup 70 GWd/MTU
5 years	1.6 kW/MTU	2.3	2.8	3.5
15 years	0.9	1.3	1.6	2.2
60 years	0.4	0.5	0.7	0.9
200 years	0.2	0.2	0.2	0.3

Source: IAEA 2011. Values are estimated from Figure 13 of the report.

Table I-2. Dependence of neutron emission on burnup and cooling year for UOX fuel

Decay Time	Burnup 30 GWd/MTU	Burnup 45 GWd/MTU	Burnup 55 GWd/MTU	Burnup 70 GWd/MTU
5 years	0.25	0.6	0.9	1.4
15 years	0.2	0.4	0.6	1.0
60 years	0.01	0.1	0.15	0.2
200 years	NS	NS	NS	NS

Source: IAEA 2011. Values were estimated from Table 15 of the report.

Neutron emissions in Giga neutrons per second per metric tons of uranium (Gn/s/ MTU).

NS = not significant. Values were too small to determine from Figure 15 (i.e., <0.01).

Q. How do degradation processes affect storage of high-burnup spent fuel?

- A. As storage times have increased, so has interest in improving the understanding of degradation mechanisms that affect spent fuel as it is stored. Recent reports have identified a variety of degradation mechanisms and discussed the potential effects on storage (e.g., NRC 2012, Hanson et al. 2012, IAEA 2011, and Sindelar et al. 2011).

The mechanical integrity of the spent fuel cladding and assembly is important for ensuring that handling and transportation of spent fuel can be conducted with relative ease. The mechanical designs of lower-burnup UOX fuel and higher-burnup UOX and MOX fuel are very similar, but some of the after-irradiation properties of higher-burnup UOX and MOX fuel are potentially significant in determining the rate of degradation or differences in performance. Examples of the differences in after-irradiation properties between lower-burnup UOX fuel and higher-burnup UOX and MOX fuel include higher fuel rod internal pressures and thinner cladding due to more cladding oxidation and hydride layer buildup causing higher cladding stress; higher decay heat; higher specific activity; and finer grain structure of the fuel pellet, which potentially would increase the source term in the event of an accident.

The IAEA has provided a useful perspective on the impact of degradation processes for both wet and dry storage systems:

“Because wet storage is associated with low temperatures, cladding degradation is expected to be low. High-burnup UOX and MOX storage will increase the heat load, and potentially radioactive releases. This may require an upgrade of the pool facility with respect to heat removal and pool cleanup systems, and additional neutron poison material in the pool water or in storage racks. Re-evaluation of criticality and regulatory aspects may also be required. In dry storage and transportation, the cask has to provide safe confinement/containment. In parallel, the decay heat has to be removed to limit temperature induced material alterations. Thus, dry storage is more sensitive to increased UOX burnup and MOX use than wet storage because of higher temperatures resulting in higher stresses on the cladding. The ability to meet applicable regulatory limits will need to be re-evaluated for higher burnup UOX and MOX on a case by case basis. Sub-criticality during transportation has to be ensured even under accident conditions, such as, for example, cask drop. Higher burnup fuel may have significantly more hydrogen in the cladding and structure and, thus, reduced ductility. Since MOX fuel has a similar design to UOX fuel, its mechanical behaviour should not be different. The result of these evaluations for storage and transportation may require a redesign of the cask heat removal and shielding systems, redesign of the structural support for the spent fuel assemblies, a decrease in the number of spent fuel assemblies that can be placed into a single storage cask, and an increased decay time in the pool prior to placement in dry storage.” (IAEA 2011)

Appendix I

The NRC continues to follow international and national efforts on degradation mechanisms, and is conducting its own, NRC-funded studies to ensure that its understanding of these processes is sufficient and to use the increasing information and operational experience with storage, handling, and transportation of spent fuel to confirm the adequacy of or make any necessary changes to the regulatory framework.

Q. Can high-burnup fuel be transported?

A. Yes. The NRC has certified transportation packages for the transport of spent fuel, and some of these packages have been authorized to carry high-burnup fuel. The NRC approves designs only after a full safety review. Based on these reviews, the NRC has certified package designs to transport high-burnup fuel currently in storage at ISFSIs including, for example, the NAC-UMS, HI-STAR 100, and MP-197. Transportation of spent fuel would be accomplished in accordance with NRC regulations (i.e., 10 CFR Parts 20 and 71) and applicable U.S. Department of Transportation requirements. A list of NRC-certified storage casks and transportation casks for high-burnup spent fuel is provided in Appendix G.

Q. Is the NRC doing any research on high-burnup fuel?

- A.** Yes, the NRC has a number of recently completed or in-progress research projects on high-burnup fuel.
- 1) *Effects of hydride reorientation on the ductility of the cladding.* This recently completed project conducted at Argonne National Laboratory, showed that, hydride reorientation will occur to some extent under many conditions of storage, with the degree depending on the cladding material, cold work, stress, hydrogen content, and maximum temperature. The research indicated that, if the cladding remains above the ductile to brittle transition temperature, it should be ductile. Below that temperature, the cladding must be considered to be potentially brittle. The U.S. Department of Energy (DOE) is continuing this research.
 - 2) *Effects of transportation vibrations on the integrity of high-burnup fuel cladding.* Preliminary results from this research project, being conducted at Oak Ridge National Laboratory, shows that Zircaloy-4 cladding of high-burnup fuel should not fail under normal transportation road or rail vibration loads. This research is expected to be completed in 2014, then will be continued by the DOE on other fuel rod cladding materials.
 - 3) *Stress loads on the cladding.* While stress due to gases in the high-burnup fuel rods has been shown to be insufficient to cause a thermal low-temperature creep or delayed hydride cracking, stress also could be exerted by swelling of the pellets over time due to

the internal generation of helium due to fission product decay. Laboratory studies have shown this would not be expected to occur until after 100 years of storage. The NRC is conducting an evaluation on the potential cladding stress due to pellet swelling to determine if further research is necessary to rule this out as a plausible degradation mechanism.

While all available data has shown that high-burnup fuel can be safely stored, the NRC is following the cask demonstration project, which will look for early signs of fuel degradation. The NRC will independently evaluate data obtained from this DOE demonstration so it is in a position to make changes to its regulatory framework, if necessary.

Q. How is high-burnup fuel considered in the GEIS?

- A.** The environmental impacts described in the GEIS do not require separate consideration of high-burnup fuel because the unique characteristics of high-burnup fuel are not a factor in environmental impact assessment for the resource areas considered.

As discussed in Section 2.1.1.3, the use of high-burnup fuel could create less spent fuel than a facility that uses low-burnup fuel, while providing the same energy output. Therefore, for most resource areas evaluated in the GEIS, the impacts of storing high-burnup fuel would be the same as or slightly less than the impacts associated with storing low-burnup fuel. This is primarily because storing less spent fuel would require less land. This result is consistent with earlier published analyses of the environmental effects of high-burnup fuel (Ramsdell et al. 2001) that included the impacts from handling accidents, transportation, and onsite storage in support of environmental assessments of operating nuclear power plants.

References

10 CFR Part 20. *Code of Federal Regulations*, Title 10, *Energy*, Part 20, “Standards for Protection Against Radiation.” Washington, D.C.

10 CFR Part 71. *Code of Federal Regulations*, Title 10, *Energy*, Part 71, “Packaging and Transportation of Radioactive Material.” Washington, D.C.

10 CFR Part 72. *Code of Federal Regulations*, Title 10, *Energy*, Part 72, “Licensing Requirements for the Independent Storage of Spent Nuclear Fuel, High-Level Radioactive Waste, and Reactor-Related Greater than Class C Waste.” Washington, D.C.

Hanson, B., H. Alsaed, C. Stockman, D. Enos, R. Meyer, and K. Sorenson. 2012. *Gap Analysis to Support Extended Storage of Used Nuclear Fuel Rev. 0*. U.S. Department of Energy Report No. FCRD-USED-2011-000136 Rev. 0, Richland, Washington. Available at <http://energy.gov/sites/prod/files/Gap%20Analysis%20Rev%200%20Final.pdf>.

Appendix I

IAEA (International Atomic Energy Agency). 2011. *Impact of High Burnup Uranium Oxide and Mixed Uranium–Plutonium Oxide Water Reactor Fuel on Spent Fuel Management*. IAEA Nuclear Energy Series No. NF-T-3.8, Vienna, Austria. Available at http://www-pub.iaea.org/MTCD/Publications/PDF/Pub1490_web.pdf.

National Environmental Policy Act of 1969 (NEPA), as amended. 42 USC 4321 *et seq.*

NRC (U.S. Nuclear Regulatory Commission). 1987. *Standard Review Plan for the Review of Safety Analysis Reports for Nuclear Power Plants: LWR Edition*. NUREG-800, Revision 2, Washington, D.C. Accession No. ML070810350.

NRC (U.S. Nuclear Regulatory Commission). 2012. *Identification and Prioritization of the Technical Information Needs Affecting Potential Regulation of Extended Storage and Transportation of Spent Nuclear Fuel: Draft Report for Comment*. Washington, D.C. Accession No. ML120580143.

Ramsdell, J.V., Jr., C.E. Beyer, D.D. Lanning, U.P. Jenquin, R.A. Schwarz, D.L. Strenge, P.M. Daling, and R.T. Dahowski. 2001. *Environmental Effects of Extending Fuel Burnup Above 60 GWd/MTU*. NUREG/CR-6703, Pacific Northwest National Laboratory, Richland, Washington. Accession No. ML010310298.

Sindelar, R.L., A.J. Duncan, M.E. Dupont, P.-S. Lam, M.R. Louthan, Jr., and T.E. Skidmore. 2011. *Materials Aging Issues and Aging Management for Extended Storage and Transportation of Spent Nuclear Fuel*. NUREG/CR-7116, Savannah River National Laboratory, Aiken, South Carolina. Accession No. ML11321A182.

Transnuclear Inc. 2009. *Technical Specifications: TransNuclear Inc. Standardized NUHOMS Horizontal Modular Storage System Certificate of Compliance No. 1004, Amendment No. 10*. Docket 72-1004, Columbia, Maryland. Accession No. ML092290186.

BIBLIOGRAPHIC DATA SHEET

(See instructions on the reverse)

2. TITLE AND SUBTITLE

Generic Environmental Impact Statement for Continued Storage of Spent Nuclear Fuel - Final Report and Public Comments

3. DATE REPORT PUBLISHED

MONTH

YEAR

September

2014

4. FIN OR GRANT NUMBER

5. AUTHOR(S)

U.S. NRC

6. TYPE OF REPORT

Technical

7. PERIOD COVERED (Inclusive Dates)

8. PERFORMING ORGANIZATION - NAME AND ADDRESS (If NRC, provide Division, Office or Region, U. S. Nuclear Regulatory Commission, and mailing address; if contractor, provide name and mailing address.)

Waste Confidence Directorate
Office of Nuclear Material Safety and Safeguards
U.S. Nuclear Regulatory Commission
Washington, DC 20555-0001

9. SPONSORING ORGANIZATION - NAME AND ADDRESS (If NRC, type "Same as above", if contractor, provide NRC Division, Office or Region, U. S. Nuclear Regulatory Commission, and mailing address.)

Same as above

10. SUPPLEMENTARY NOTES

11. ABSTRACT (200 words or less)

This Generic Environmental Impact Statement for Continued Storage of Spent Nuclear Fuel (GEIS) examines the potential environmental impacts that could occur as a result of the continued storage of spent nuclear fuel at at-reactor and away-from-reactor sites until a repository is available. For the resource areas considered, this GEIS attempts to establish generic impact determinations that would be applicable to a wide range of existing and potential future spent fuel storage sites. While some site-specific information is used in developing the generic impact determinations, the NRC does not intend for this GEIS to replace the NEPA analysis associated with any individual licensing action. This GEIS makes maximum use of existing environmental impact determinations, site-specific data, publicly available literature, and public comments received.

This GEIS evaluated alternatives to the proposed action, including options under the no-action alternative (site-specific licensing review, a GEIS-only option, and a policy statement). The proposed action would have the same potential environmental impacts as any of the alternatives evaluated. However, as shown in quantitative analysis of costs, the cost for the proposed action is less than the cost for any of the alternatives.

12. KEY WORDS/DESCRIPTORS (List words or phrases that will assist researchers in locating the report.)

EIS, GEIS, environmental impact statement, NEPA, national environmental policy act, waste confidence, waste confidence decision, waste confidence rule, continued storage

13. AVAILABILITY STATEMENT

unlimited

14. SECURITY CLASSIFICATION

(This Page)

unclassified

(This Report)

unclassified

15. NUMBER OF PAGES

16. PRICE



Federal Recycling Program



**UNITED STATES
NUCLEAR REGULATORY COMMISSION**
WASHINGTON, DC 20555-0001

OFFICIAL BUSINESS



**NUREG-2157, Vol. 1
Final**

**Generic Environmental Impact Statement for
Continued Storage of Spent Nuclear Fuel**

September 2014